



**THE DATASHEET OF
LM95213CISD/NOPB**



2-Diode Input and Local Digital Temperature Sensor with Two-Wire Interface and $\overline{\text{TCRIT}}$ Outputs

Check for Samples: [LM95213](#)

FEATURES

- Accurately Senses Die Temperature of 2 Remote ICs or Diode Junctions and Local Temperature
- 0.125°C LSB Temperature Resolution
- 0.03125°C LSB Remote Temperature Resolution with Digital Filter Enabled
- +127.875°C/–128°C and 0°C/255°C Remote Ranges
- Programmable Digital Filters and Analog Front End Filter
- Remote Diode Fault Detection, Model Selection and Offset Correction
- Mask and Status Register Support
- 3 Programmable $\overline{\text{TCRIT}}$ Outputs with Programmable Shared Hysteresis
- Programmable Conversion Rate and Shutdown Mode One-Shot Conversion Control
- SMBus 2.0 Compatible Interface, Supports TIMEOUT
- Three-Level Address Pin
- 14-Pin WSON Package

APPLICATIONS

- Processor/Computer System Thermal Management (e.g. Laptop, Desktop, Workstations, Server)
- Electronic Test Equipment
- Office Electronics

DESCRIPTION

The LM95213 is an 11-bit digital temperature sensor with a 2-wire System Management Bus (SMBus) interface that can monitor the temperature of two remote diodes as well as its own temperature. The LM95213 can be used to very accurately monitor the temperature of up to two external devices such as microprocessors, graphics processors or diode-connected 2N3904s.

The LM95213 reports temperature in two different formats for +127.875°C/–128°C range and 0°C/255°C range. The LM95213 $\overline{\text{TCRIT1}}$, $\overline{\text{TCRIT2}}$ and $\overline{\text{TCRIT3}}$ outputs are triggered when any unmasked channel exceeds its corresponding programmable limit and can be used to shutdown the system, to turn on the system fans or as a microcontroller interrupt function. The current status of the $\overline{\text{TCRIT1}}$, $\overline{\text{TCRIT2}}$ and $\overline{\text{TCRIT3}}$ pins can be read back from the status registers. Mask registers are available for further control of the $\overline{\text{TCRIT}}$ outputs.

The LM95213's remote temperature channels have programmable digital filters to minimize unwanted $\overline{\text{TCRIT}}$ events when temperature spikes are encountered.

For optimum flexibility and accuracy each LM95213 channel includes offset correction registers for targeting diodes other than the 2N3904. A three level address pin allows connection of up to 3 LM95213s to the same SMBus master. The LM95213 includes power saving functions such as: programmable conversion rate, shutdown mode, and turn off of unused channels.

Table 1. Key Specifications

	VALUE	UNIT
Local Temperature Accuracy	±2.0	°C (max)
Remote Diode Temperature Accuracy	±1.1	°C (max)
Supply Voltage	3.0 to 3.6	V
Average Supply Current (1Hz conversion rate)	0.57	mA (typ)



Please be aware that an important notice concerning availability, standard warranty, and use in critical applications of Texas Instruments semiconductor products and disclaimers thereto appears at the end of this data sheet.

TruTherm is a trademark of Texas Instruments.

All other trademarks are the property of their respective owners.

Connection Diagram

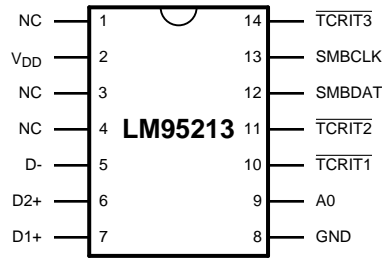
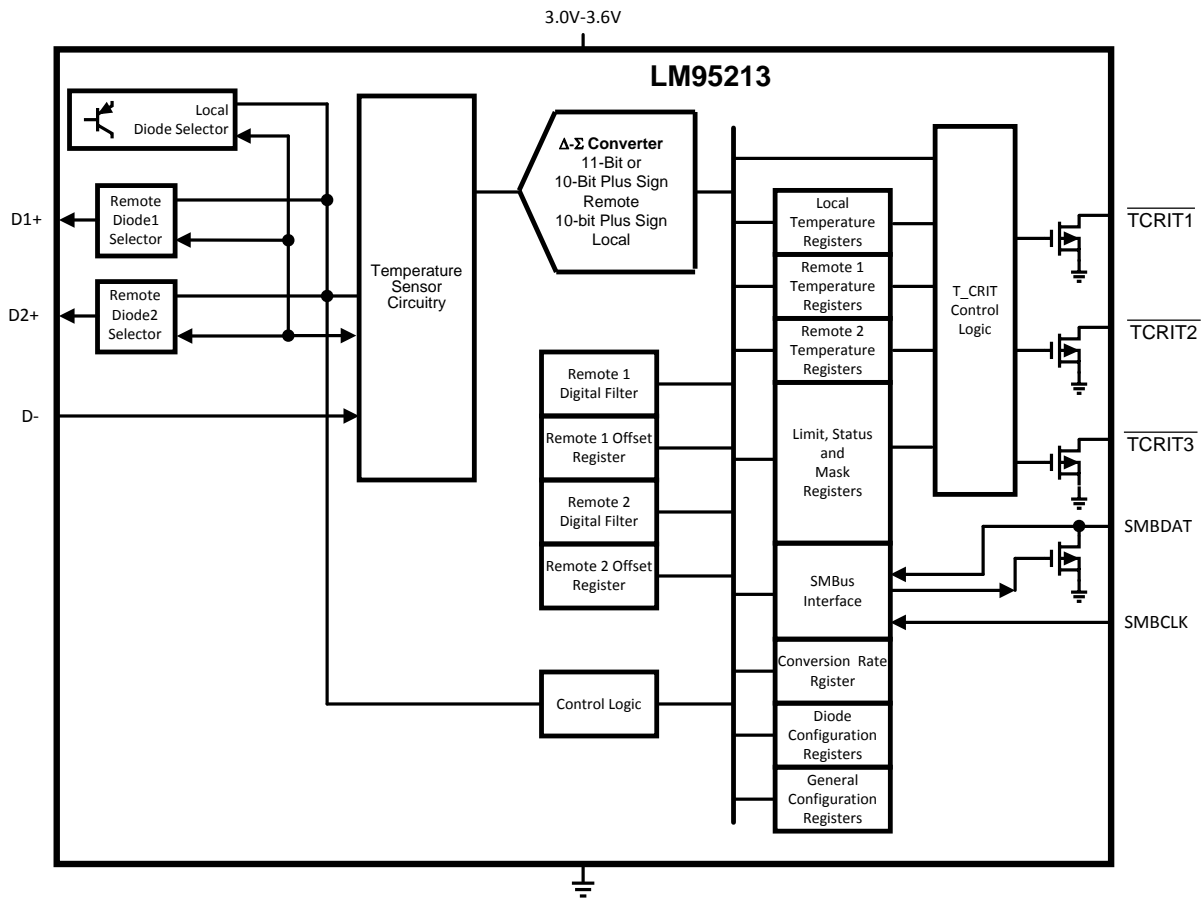

Figure 1. 14-Lead WSON - TOP VIEW
See NHL0014B Package

Simplified Block Diagram



PIN DESCRIPTIONS

Label	Pin #	Function	Typical Connection
NC	1	No Connect	Not connected. May be left floating, connected to GND or V _{DD} .
V _{DD}	2	Positive Supply Voltage Input	DC Voltage from 3.0 V to 3.6 V. V _{DD} should be bypassed with a 0.1µF capacitor in parallel with 100pF. The 100pF capacitor should be placed as close as possible to the power supply pin. Noise should be kept below 200 mVp-p, a 10 µF capacitor may be required to achieve this.
NC	3	No Connect	Not connected. May be left floating, connected to GND or V _{DD} .
NC	4	No Connect	Not connected. May be left floating, connected to GND or V _{DD} .
D-	5	Diode Return Current Sink	To all Diode Cathodes. Common D- pin for all two remote diodes.
D2+	6	Diode Current Source	To second Diode Anode. Connected to remote discrete diode-connected transistor junction or to the diode-connected transistor junction on a remote IC whose die temperature is being sensed. A capacitor is not required between D2+ and D-. A 100 pF capacitor between D2+ and D- can be added and may improve performance in noisy systems. Float this pin if this thermal diode is not used.
D1+	7	Diode Current Source	To first Diode Anode. Connected to remote discrete diode-connected transistor junction or to the diode-connected transistor junction on a remote IC whose die temperature is being sensed. A capacitor is not required between D1+ and D-. A 100 pF capacitor between D1+ and D- can be added and may improve performance in noisy systems. Float this pin if this thermal diode is not used.
GND	8	Power Supply Ground	System low noise ground.
A0	9	Digital Input	SMBus slave address select pin. Selects one of three addresses. Can be tied to V _{DD} , GND, or to the middle of a resistor divider connected between V _{DD} and GND.
$\overline{\text{TCRIT1}}$	10	Digital Output, Open-Drain	Critical temperature output 1. Requires pull-up resistor. Active "LOW".
$\overline{\text{TCRIT2}}$	11	Digital Output, Open-Drain	Critical temperature output 2. Requires pull-up resistor. Active "LOW".
SMBDAT	12	SMBus Bi-Directional Data Line, Open-Drain Output	From and to Controller; may require an external pull-up resistor
SMBCLK	13	SMBus Clock Input	From Controller; may require an external pull-up resistor
$\overline{\text{TCRIT3}}$	14	Digital Output, Open-Drain	Critical temperature output 3. Requires pull-up resistor. Active "LOW".

Typical Application

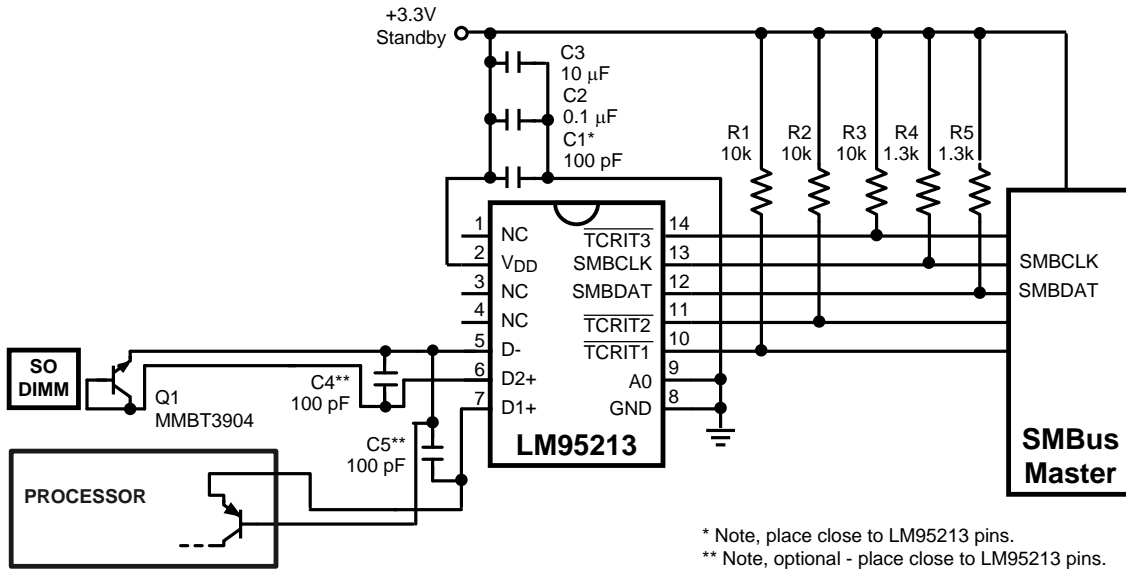

These devices have limited built-in ESD protection. The leads should be shorted together or the device placed in conductive foam during storage or handling to prevent electrostatic damage to the MOS gates.

Absolute Maximum Ratings ⁽¹⁾

Supply Voltage	-0.3V to 6.0V	
Voltage at SMBDAT, SMBCLK, TCRIT1, TCRIT2, TCRIT3	-0.5V to 6.0V	
Voltage at Other Pins	-0.3V to (V _{DD} + 0.3V)	
D- Input Current	±1 mA	
Input Current at All Other Pins ⁽²⁾	±5 mA	
Package Input Current ⁽²⁾	30 mA	
SMBDAT, TCRIT1, TCRIT2, TCRIT3 Output Sink Current	10 mA	
Storage Temperature	-65°C to +150°C	
ESD Susceptibility ⁽³⁾	Human Body Model	2000V
	Machine Model	200V
	Charge Device Model	1000V

Soldering process must comply with reflow temperature profile specifications. Refer to <http://www.ti.com/packaging> ⁽⁴⁾

- (1) Absolute Maximum Ratings indicate limits beyond which damage to the device may occur. DC and AC electrical specifications do not apply when operating the device beyond its rated operating conditions.
- (2) When the input voltage (V_I) at any pin exceeds the power supplies (V_I < GND or V_I > V_{DD}), the current at that pin should be limited to 5 mA. Parasitic components and or ESD protection circuitry are shown in the table below for the LM95213's pins.
- (3) Human body model, 100 pF discharged through a 1.5 kΩ resistor. Machine model, 200 pF discharged directly into each pin. Charged Device Model (CDM) simulates a pin slowly acquiring charge (such as from a device sliding down the feeder in an automated assembler) then rapidly being discharged.
- (4) Reflow temperature profiles are different for packages containing lead (Pb) than for those that do not.

Operating Ratings⁽¹⁾⁽²⁾

Operating Temperature Range	-40°C to +140°C
Electrical Characteristics Temperature Range	$T_{MIN} \leq T_A \leq T_{MAX}$
LM95213CISD	-40°C $\leq T_A \leq$ +125°C
Supply Voltage Range (V_{DD})	+3.0V to +3.6V

- (1) Absolute Maximum Ratings indicate limits beyond which damage to the device may occur. DC and AC electrical specifications do not apply when operating the device beyond its rated operating conditions.
- (2) Thermal resistance junction-to-ambient when attached to a 4 layer printed circuit board per JEDEC standard JESD51-7:
 14-lead WSON = 90°C/W (no thermal vias, no airflow)
 14-lead WSON = 63°C/W (1 thermal via, no airflow)
 14-lead WSON = 43°C/W (6 thermal vias, no airflow)
 14-lead WSON = 31°C/W (6 thermal vias, 900 In. ft. / min. airflow)
 Note, all quoted values include +15% error factor from nominal value.

Temperature-to-Digital Converter Electrical Characteristics

Unless otherwise noted, these specifications apply for $V_{DD} = +3.0V_{dc}$ to $3.6V_{dc}$. **Boldface limits apply for $T_A = T_J = T_{MIN} \leq T_A \leq T_{MAX}$** ; all other limits $T_A = T_J = +25^\circ C$, unless otherwise noted.

Parameter	Conditions	Typical ⁽¹⁾	Limits ⁽²⁾	Units (Limit)
Temperature Error Using Local Diode	$T_A = -40^\circ C$ to $+125^\circ C$, ⁽³⁾	± 1	± 2	°C (max)
Temperature Error Using Remote Diode ⁽⁴⁾	$T_A = +25^\circ C$ to $+85^\circ C$ $T_D = +60^\circ C$ to $+100^\circ C$		± 1.1	°C (max)
	$T_A = +25^\circ C$ to $+85^\circ C$ $T_D = -40^\circ C$ to $+125^\circ C$	MMBT3904 Transistor	± 1.3	°C (max)
	$T_A = -40^\circ C$ to $+85^\circ C$ $T_D = -40^\circ C$ to $+125^\circ C$	MMBT3904 Transistor	± 3.0	°C (max)
	$T_A = -40^\circ C$ to $+85^\circ C$ $T_D = 125^\circ C$ to $+140^\circ C$	MMBT3904 Transistor	± 3.3	°C (max)
Local Diode Measurement Resolution		11		Bits
		0.125		°C
Remote Diode Measurement Resolution	Digital Filter Off	11		Bits
		0.125		°C
	Digital Filter On (Remote Diodes 1 and 2 only)	13		Bits
		0.03125		°C
Conversion Time of All Temperatures at the Fastest Setting ⁽⁵⁾	All Channels are Enabled in Default State	1100	1210	ms (max)
	1 External Channel	31	34	ms (max)
	Local only	30	33	ms (max)
Quiescent Current ⁽⁶⁾	SMBus Inactive, 1Hz Conversion Rate, channels in default state	570	800	μA (max)
	Shutdown	360		μA
D- Source Voltage		0.4		V
Remote Diode Source Current	High level	160	230	μA (max)
	Low level	10		
Power-On Reset Threshold	Measured on V_{DD} input, falling edge		2.8 1.6	V (max) V (min)
$\overline{TCRIT1}$ Pin Temperature Threshold	Default Diodes only	+110		°C
$\overline{TCRIT2}$ Pin Temperature Threshold	Default all channels	+85		°C

- (1) Typicals are at $T_A = 25^\circ C$ and represent most likely parametric norm.
- (2) Limits are guaranteed to National's AOQL (Average Outgoing Quality Level).
- (3) Local temperature accuracy does not include the effects of self-heating. The rise in temperature due to self-heating is the product of the internal power dissipation of the LM95213 and the thermal resistance. See Thermal Resistance note under Operating Ratings for the thermal resistance to be used in the self-heating calculation.
- (4) The accuracy of the LM95213CISD is guaranteed when using a typical thermal diode of an MMBT3904 diode-connected transistor. For further information on other thermal diodes see applications [DIODE NON-IDEALITY](#).
- (5) This specification is provided only to indicate how often temperature data is updated. The LM95213 can be read at any time without regard to conversion state (and will yield last conversion result).
- (6) Quiescent current will not increase substantially with an SMBus communication.

Logic Electrical Characteristics

DIGITAL DC CHARACTERISTICS

Unless otherwise noted, these specifications apply for $V_{DD} = +3.0\text{Vdc}$ to 3.6Vdc . **Boldface limits apply for $T_A = T_J = T_{MIN}$ to T_{MAX}** ; all other limits $T_A = T_J = +25^\circ\text{C}$, unless otherwise noted.

Symbol	Parameter	Conditions	Typical ⁽¹⁾	Limits ⁽²⁾	Units (Limit)
SMBDAT, SMBCLK INPUTS					
$V_{IN(1)}$	Logical "1" Input Voltage			2.1	V (min)
$V_{IN(0)}$	Logical "0" Input Voltage			0.8	V (max)
$V_{IN(HYST)}$	SMBDAT and SMBCLK Digital Input Hysteresis		400		mV
$I_{IN(1)}$	Logical "1" Input Current	$V_{IN} = V_{DD}$	0.005	10	μA (max)
$I_{IN(0)}$	Logical "0" Input Current	$V_{IN} = 0\text{V}$	-0.005	-10	μA (max)
C_{IN}	Input Capacitance		5		pF
A0 DIGITAL INPUT					
V_{IH}	Input High Voltage			$0.90 \times V_{DD}$	V (min)
V_{IM}	Input Middle Voltage			$0.57 \times V_{DD}$	V (max)
				$0.43 \times V_{DD}$	V (min)
V_{IL}	Input Low Voltage			$0.10 \times V_{DD}$	V (max)
$I_{IN(1)}$	Logical "1" Input Current	$V_{IN} = V_{DD}$	-0.005	-10	μA (min)
$I_{IN(0)}$	Logical "0" Input Current	$V_{IN} = 0\text{V}$	0.005	10	μA (max)
C_{IN}	Input Capacitance		5		pF
SMBDAT, $\overline{\text{TCRIT1}}$, $\overline{\text{TCRIT2}}$, $\overline{\text{TCRIT3}}$ DIGITAL OUTPUTS					
I_{OH}	High Level Output Current	$V_{OH} = V_{DD}$		10	μA (max)
$V_{OL(\text{SMBDAT})}$	SMBus Low Level Output Voltage	$I_{OL} = 4\text{ mA}$ $I_{OL} = 6\text{ mA}$		0.4	V (max)
				0.6	V (max)
$V_{OL(\overline{\text{TCRIT}})}$	$\overline{\text{TCRIT1}}$, $\overline{\text{TCRIT2}}$, $\overline{\text{TCRIT3}}$ Low Level Output Voltage	$I_{OL} = 6\text{ mA}$		0.4	V (max)
C_{OUT}	Digital Output Capacitance		5		pF

(1) Typicals are at $T_A = 25^\circ\text{C}$ and represent most likely parametric norm.

(2) Limits are guaranteed to National's AOQL (Average Outgoing Quality Level).

SMBus DIGITAL SWITCHING CHARACTERISTICS

Unless otherwise noted, these specifications apply for $V_{DD} = +3.0\text{Vdc}$ to $+3.6\text{Vdc}$, C_L (load capacitance) on output lines = 80 pF. **Boldface limits apply for $T_A = T_J = T_{MIN}$ to T_{MAX}** ; all other limits $T_A = T_J = +25^\circ\text{C}$, unless otherwise noted.

The switching characteristics of the LM95213 fully meet or exceed the published specifications of the SMBus version 2.0. The following parameters are the timing relationships between SMBCLK and SMBDAT signals related to the LM95213. They adhere to but are not necessarily the SMBus bus specifications.

Symbol	Parameter	Conditions	Typical ⁽¹⁾	Limits ⁽²⁾	Units (Limit)
f_{SMB}	SMBus Clock Frequency			100 10	kHz (max) kHz (min)
t_{LOW}	SMBus Clock Low Time	from $V_{IN(0)\text{max}}$ to $V_{IN(0)\text{min}}$		4.7 25	μs (min) ms (max)
t_{HIGH}	SMBus Clock High Time	from $V_{IN(1)\text{min}}$ to $V_{IN(1)\text{max}}$		4.0	μs (min)
$t_{\text{R,SMB}}$	SMBus Rise Time	See ⁽³⁾	1		μs (max)
$t_{\text{F,SMB}}$	SMBus Fall Time	See ⁽⁴⁾	0.3		μs (max)
t_{OF}	Output Fall Time	$C_L = 400\text{ pF}$, $I_O = 3\text{ mA}$, ⁽⁴⁾		250	ns (max)

(1) Typicals are at $T_A = 25^\circ\text{C}$ and represent most likely parametric norm.

(2) Limits are guaranteed to National's AOQL (Average Outgoing Quality Level).

(3) The output rise time is measured from $(V_{IN(0)\text{max}} - 0.15\text{V})$ to $(V_{IN(1)\text{min}} + 0.15\text{V})$.

(4) The output fall time is measured from $(V_{IN(1)\text{min}} + 0.15\text{V})$ to $(V_{IN(0)\text{max}} - 0.15\text{V})$.

SMBus DIGITAL SWITCHING CHARACTERISTICS

Unless otherwise noted, these specifications apply for $V_{DD}=+3.0$ Vdc to +3.6 Vdc, C_L (load capacitance) on output lines = 80 pF. **Boldface limits apply for $T_A = T_J = T_{MIN}$ to T_{MAX}** ; all other limits $T_A = T_J = +25^\circ\text{C}$, unless otherwise noted.

The switching characteristics of the LM95213 fully meet or exceed the published specifications of the SMBus version 2.0. The following parameters are the timing relationships between SMBCLK and SMBDAT signals related to the LM95213. They adhere to but are not necessarily the SMBus bus specifications.

Symbol	Parameter	Conditions	Typical ⁽¹⁾	Limits ⁽²⁾	Units (Limit)
$t_{TIMEOUT}$	SMBDAT and SMBCLK Time Low for Reset of Serial Interface ⁽⁵⁾			25 35	ms (min) ms (max)
$t_{SU;DAT}$	Data In Setup Time to SMBCLK High			250	ns (min)
$t_{HD;DAT}$	Data Out Stable after SMBCLK Low			300 1075	ns (min) ns (max)
$t_{HD;STA}$	Start Condition SMBDAT Low to SMBCLK Low (Start condition hold before the first clock falling edge)			100	ns (min)
$t_{SU;STO}$	Stop Condition SMBCLK High to SMBDAT Low (Stop Condition Setup)			100	ns (min)
$t_{SU;STA}$	SMBus Repeated Start-Condition Setup Time, SMBCLK High to SMBDAT Low			0.6	μs (min)
t_{BUF}	SMBus Free Time Between Stop and Start Conditions			1.3	μs (min)

(5) Holding the SMBDAT and/or SMBCLK lines Low for a time interval greater than $t_{TIMEOUT}$ will reset the LM95213's SMBus state machine, therefore setting SMBDAT and SMBCLK pins to a high impedance state.

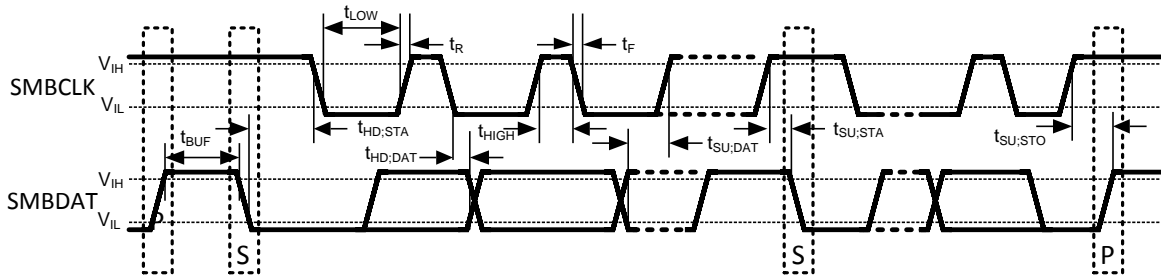

Figure 2. SMBus Communication

Pin #	Label	Circuit	Circuits for Pin ESD Protection Structure
1	NC	–	<p>Circuit A</p>
2	V_{DD}	A	
3	NC	–	
4	NC	–	
5	D-	A	
6	D2+	A	
7	D1+	A	
8	GND	–	<p>Circuit B</p>
9	A0	B	
10	$\overline{TCRIT1}$	B	
11	$\overline{TCRIT2}$	B	
12	SMBDAT	B	
13	SMBCLK	B	
14	$\overline{TCRIT2}$	B	

Typical Performance Characteristics

Conversion Rate Effect on Average Power Supply Current

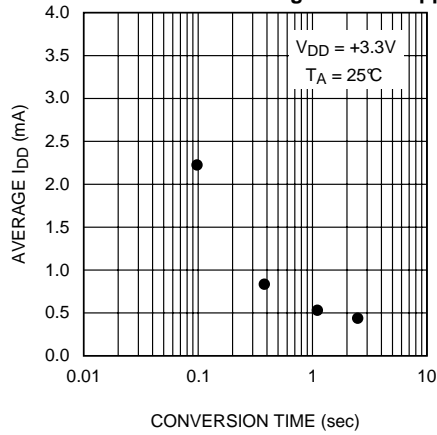

Figure 3.

Thermal Diode Capacitor or PCB Leakage Current Effect on Remote Diode Temperature Reading

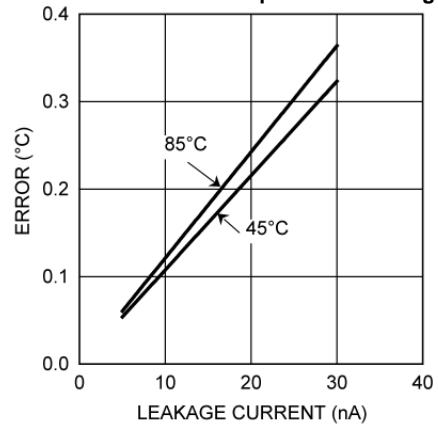

Figure 4.

Remote Temperature Reading Sensitivity to Thermal Diode Filter Capacitance,

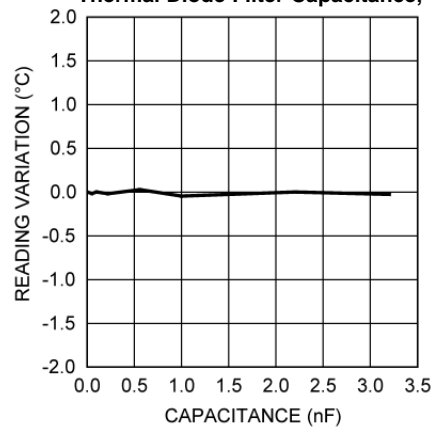

Figure 5.

FUNCTIONAL DESCRIPTION

LM95213 is an 11-bit digital temperature sensor with a 2-wire System Management Bus (SMBus) interface that can monitor the temperature of two remote diodes as well as its own temperature. The LM95213 can be used to very accurately monitor the temperature of up to two external devices such as microprocessors, graphics processors or diode-connected 2N3904 transistor.

The LM95213 reports temperature in two different formats for +127.875°C/–128°C range and 0°C/255°C range. The LM95213 has a Sigma-Delta ADC (Analog-to-Digital Converter) core which provides the first level of noise immunity. For improved performance in a noisy environment the LM95213 includes programmable digital filters for Remote Diode 1 and 2 temperature readings. When the digital filters are invoked the resolution for Remote Diode 1 and 2 readings increases to 0.03125°C. For maximum flexibility and best accuracy the LM95213 includes offset registers that allow calibration of other diode types.

Diode fault detection circuitry in the LM95213 can detect the absence or fault state of a remote diode: whether D+ is shorted to V_{DD} , D- or ground, or whether D+ is floating.

The LM95213 $\overline{\text{TCRIT1}}$, $\overline{\text{TCRIT2}}$ and $\overline{\text{TCRIT3}}$ active low outputs are triggered when any unmasked channel exceeds its corresponding programmable limit and can be used to shutdown the system, to turn on the system fans or as a microcontroller interrupt function. The current status of the $\overline{\text{TCRIT1}}$, $\overline{\text{TCRIT2}}$ and $\overline{\text{TCRIT3}}$ pins can be read back from the status registers via the SMBus interface. The remote channels have two separate limits each that control the $\overline{\text{TCRIT1}}$ and $\overline{\text{TCRIT2}}$ pins. The $\overline{\text{TCRIT3}}$ pin shares the limits of the $\overline{\text{TCRIT2}}$ pin but allows for different masking options. All limits have a shared programmable hysteresis register.

Remote Diode temperature channels have programmable digital filters in order to avoid false triggering the $\overline{\text{TCRIT}}$ pins.

LM95213 has a three-level address pin to connect up to 3 devices to the same SMBus master. LM95213 also has programmable conversion rate register as well as a shutdown mode for power savings. One round of conversions can be triggered in shutdown mode by writing to the one-shot register through the SMBus interface. LM95213 can be programmed to turn off unused channels for more power savings.

The LM95213 register set has an 8-bit data structure and includes:

1. Temperature Value Registers with signed format
 - Most-Significant-Byte (MSB) and Least-Significant-Byte (LSB) Local Temperature
 - MSB and LSB Remote Temperature 1
 - MSB and LSB Remote Temperature 2
2. Temperature Value Registers with unsigned format
 - MSB and LSB Remote Temperature 1
 - MSB and LSB Remote Temperature 2
3. Diode Configuration Registers
 - Remote 1 Offset
 - Remote 2 Offset
4. General Configuration Registers
 - Configuration (Standby, Conversion Rate)
 - Channel Conversion Enable
 - Filter Setting for Remote 1 and 2
 - 1-Shot
5. Status Registers
 - Main Status Register (Busy bit, Not Ready, Status Register 1 to 4 Flags)
 - Status 1 (diode fault)
 - Status 2 (TCRIT1)
 - Status 3 (TCRIT2)
 - Status 4 (TCRIT3)
6. Mask Registers
 - TCRIT1 Mask
 - TCRIT2 Mask

- TCRIT3 Mask
7. Limit Registers
- Local Tcrit Limit
 - Remote 1 Tcrit-1 Limit
 - Remote 2 Tcrit-1 Limit
 - Remote 1 Tcrit-2 and Tcrit-3 Limit
 - Remote 2 Tcrit-2 and Tcrit-3 Limit
 - Common Tcrit Hysteresis
8. Manufacturer ID Register
9. Revision ID Register

CONVERSION SEQUENCE

The LM95213 takes approximately 92 ms to convert the Local Temperature, Remote Temperatures 1 and 2, and to update all of its registers. These conversions for each thermal diode are addressed in a round robin sequence. Only during the conversion process the busy bit (D7) in Status register (02h) is high. The conversion rate may be modified by the Conversion Rate bits found in the Configuration Register (03h). When the conversion rate is modified a delay is inserted between each round of conversions, the actual time for each round remains at 92 ms (typical all channels enabled). The time a round takes depends on the number of channels that are on. Different conversion rates will cause the LM95213 to draw different amounts of average supply current as shown in Figure 6. This curve assumes all the channels are on. If channels are turned off the average current will drop since the round robin time will decrease and the shutdown time will increase during each conversion interval.

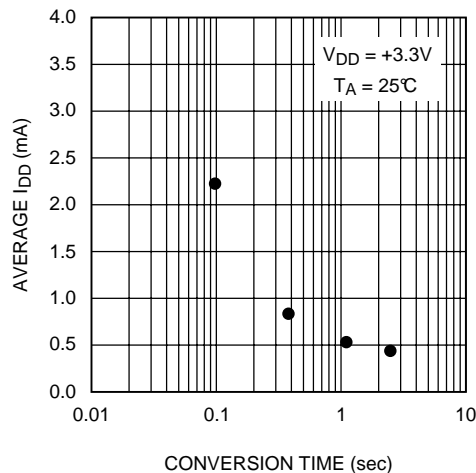

Figure 6. Conversion Rate Effect on Power Supply Current

POWER-ON-DEFAULT STATES

LM95213 always powers up to these known default states. The LM95213 remains in these states until after the first conversion.

1. All Temperature readings set to 0°C until the end of the first conversion
2. Remote offset for all channels 0°C
3. Configuration: Active converting
4. Continuous conversion with all channels enabled, time = 1s
5. Enhanced digital filter enabled for Remote 1 and 2
6. Status Registers depends on state of thermal diode inputs
7. Local and Remote Temperature Limits for $\overline{\text{TCRIT1}}$, $\overline{\text{TCRIT2}}$ and $\overline{\text{TCRIT3}}$ outputs:

Output Pin	Temperature Channel Limit		
	Remote 2 (°C)	Remote 1 (°C)	Local (°C)
$\overline{\text{TCRIT1}}$	110	110	Masked, 85
$\overline{\text{TCRIT2}}$	85	85	85
$\overline{\text{TCRIT3}}$	Masked, 85	Masked, 85	Masked, 85

8. Manufacturers ID set to 01h
9. Revision ID set to 7Bh

SMBus INTERFACE

The LM95213 operates as a slave on the SMBus, so the SMBCLK line is an input and the SMBDAT line is bidirectional. The LM95213 never drives the SMBCLK line and it does not support clock stretching. According to SMBus specifications, the LM95213 has a 7-bit slave address. Three SMBus device address can be selected by connecting A0 (pin 6) to either Low, Mid-Supply or High voltages. The LM95213 has the following SMBus slave address:

A0 Pin State	SMBus Device Address A[6:0]	
	Hex	Binary
Low	18h	001 1000
Mid-Supply	2Ah	010 1010
High	2Bh	010 1011

TEMPERATURE CONVERSION SEQUENCE

Each of the 3 temperature channels of LM95213 can be turned OFF independent from each other via the Channel Enable Register. Turning off unused channels will increase the conversion speed in the fastest conversion speed mode. If the slower conversion speed settings are used, disabling unused channels will reduce the average power consumption of LM95213.

DIGITAL FILTER

In order to suppress erroneous remote temperature readings due to noise as well as increase the resolution of the temperature, the LM95213 incorporates a digital filter for Remote 1 and 2 Temperature Channels. When a filter is enabled the filtered readings are used for the TCRIT comparisons. There are two possible digital filter settings that are enabled through the Filter Setting Register at register address 0Fh. The filter for each channel can be set according to the following table:

R1F[1:0] or R2F[1:0]		Filter Setting
0	0	No Filter
0	1	Filter (equivalent to Level 2 filter of the LM86/LM89)
1	0	Reserved
1	1	Enhanced Filter (Filter with transient noise clipping)

Figure 7 describes the filter output in response to a step input and an impulse input.

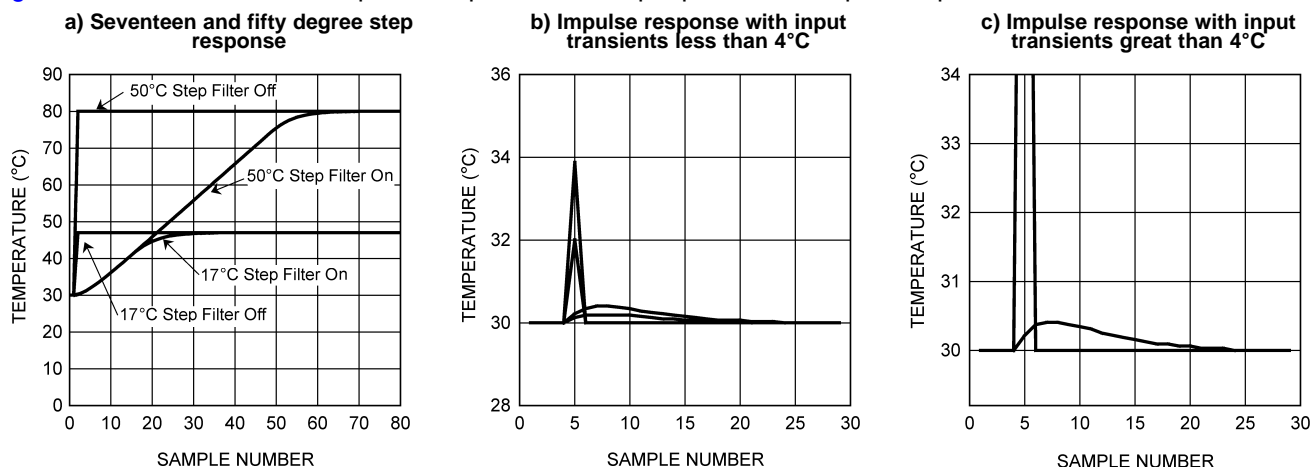

Figure 7. Filter Impulse and Step Response Curves

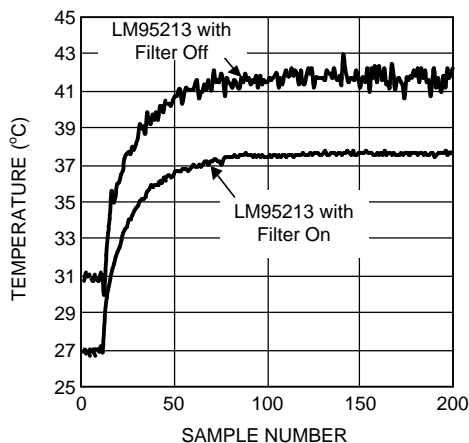

Figure 8. Digital Filter Response in a typical processor system. The filter curves were purposely offset for clarity.

Figure 8 shows the filter in use in a typical processor system. Note that the two curves have been purposely offset for clarity. Inserting the filter does not induce an offset as shown.

TEMPERATURE DATA FORMAT

Temperature data can only be read from the Local and Remote Temperature value registers. The data format for all temperature values is left justified 16-bit word available in two 8-bit registers. Unused bits will always report "0". All temperature data is clamped and will not roll over when a temperature exceeds full-scale value.

Remote temperature data for all channels can be represented by an 11-bit, two's complement word or unsigned binary word with an LSb (Least Significant Bit) equal to 0.125°C.

Table 2. 11-bit, 2's complement (10-bit plus sign)

Temperature	Digital Output	
	Binary	Hex
+125°C	0111 1101 0000 0000	7D00h
+25°C	0001 1001 0000 0000	1900h
+1°C	0000 0001 0000 0000	0100h
+0.125°C	0000 0000 0010 0000	0020h

Table 2. 11-bit, 2's complement (10-bit plus sign) (continued)

Temperature	Digital Output	
	Binary	Hex
0°C	0000 0000 0000 0000	0000h
-0.125°C	1111 1111 1110 0000	FFE0h
-1°C	1111 1111 0000 0000	FF00h
-25°C	1110 0111 0000 0000	E700h
-55°C	1100 1001 0000 0000	C900h

Table 3. 11-bit, unsigned binary

Temperature	Digital Output	
	Binary	Hex
+255.875°C	1111 1111 1110 0000	FFE0h
+255°C	1111 1111 0000 0000	FF00h
+201°C	1100 1001 0000 0000	C900h
+125°C	0111 1101 0000 0000	7D00h
+25°C	0001 1001 0000 0000	1900h
+1°C	0000 0001 0000 0000	0100h
+0.125°C	0000 0000 0010 0000	0020h
0°C	0000 0000 0000 0000	0000h

When the digital filter is enabled on Remote 1 and 2 channels temperature data is represented by a 13-bit unsigned binary or 12-bit plus sign (two's complement) word with an LSb equal to 0.03125°C.

Table 4. 13-bit, 2's complement (12-bit plus sign)

Temperature	Digital Output	
	Binary	Hex
+125°C	0111 1101 0000 0000	7D00h
+25°C	0001 1001 0000 0000	1900h
+1°C	0000 0001 0000 0000	0100h
+0.03125°C	0000 0000 0000 1000	0008h
0°C	0000 0000 0000 0000	0000h
-0.03125°C	1111 1111 1111 1000	FFF8h
-1°C	1111 1111 0000 0000	FF00h
-25°C	1110 0111 0000 0000	E700h
-55°C	1100 1001 0000 0000	C900h

Table 5. 13-bit, unsigned binary

Temperature	Digital Output	
	Binary	Hex
+255.875°C	1111 1111 1110 0000	FFE0h
+255°C	1111 1111 0000 0000	FF00h
+201°C	1100 1001 0000 0000	C900h
+125°C	0111 1101 0000 0000	7D00h
+25°C	0001 1001 0000 0000	1900h
+1°C	0000 0001 0000 0000	0100h
+0.03125°C	0000 0000 0000 1000	0008h
0°C	0000 0000 0000 0000	0000h

Local Temperature data is only represented by an 11-bit, two's complement, word with an LSb equal to 0.125°C.

Table 6. 11-bit, 2's complement (10-bit plus sign)

Temperature	Digital Output	
	Binary	Hex
+125°C	0111 1101 0000 0000	7D00h
+25°C	0001 1001 0000 0000	1900h
+1°C	0000 0001 0000 0000	0100h
+0.125°C	0000 0000 0010 0000	0020h
0°C	0000 0000 0000 0000	0000h
-0.125°C	1111 1111 1110 0000	FFE0h
-1°C	1111 1111 0000 0000	FF00h
-25°C	1110 0111 0000 0000	E700h
-55°C	1100 1001 0000 0000	C900h

SMBDAT OPEN-DRAIN OUTPUT

The SMBDAT output is an open-drain output and does not have internal pull-ups. A “high” level will not be observed on this pin until pull-up current is provided by some external source, typically a pull-up resistor. Choice of resistor value depends on many system factors but, in general, the pull-up resistor should be as large as possible without effecting the SMBus desired data rate. This will minimize any internal temperature reading errors due to internal heating of the LM95213. The maximum resistance of the pull-up to provide a 2.1V high level, based on LM95213 specification for High Level Output Current with the supply voltage at 3.0V, is 82 kΩ (5%) or 88.7 kΩ (1%).

$\overline{\text{TCRIT1}}$, $\overline{\text{TCRIT2}}$, AND $\overline{\text{TCRIT3}}$ OUTPUTS

The LM95213's $\overline{\text{TCRIT}}$ pins are active-low open-drain outputs and do not include internal pull-up resistors. A “high” level will not be observed on these pins until pull-up current is provided by some external source, typically a pull-up resistor. Choice of resistor value depends on many system factors but, in general, the pull-up resistor should be as large as possible without effecting the performance of the device receiving the signal. This will minimize any internal temperature reading errors due to internal heating of the LM95213. The maximum resistance of the pull-up to provide a 2.1V high level, based on LM95213 specification for High Level Output Current with the supply voltage at 3.0V, is 82 kΩ (5%) or 88.7 kΩ (1%). The three $\overline{\text{TCRIT}}$ pins can each sink 6 mA of current and still guarantee a “Logic Low” output voltage of 0.4V. If all three pins are set at maximum current this will cause a power dissipation of 7.2 mW. This power dissipation combined with a thermal resistance of 77.8°C/W will cause the LM95213's junction temperature to rise approximately 0.6°C and thus cause the Local temperature reading to shift. This can only be cancelled out if the environment that the LM95213 is enclosed in has stable and controlled air flow over the LM95213, as airflow can cause the thermal resistance to change dramatically.

TCRIT LIMITS AND $\overline{\text{TCRIT}}$ OUTPUTS

Figure 9 describes a simplified diagram of the temperature comparison and status register logic. Figure 10 describes a simplified logic diagram of the circuitry associated with the status registers, mask registers and the $\overline{\text{TCRIT}}$ output pins.

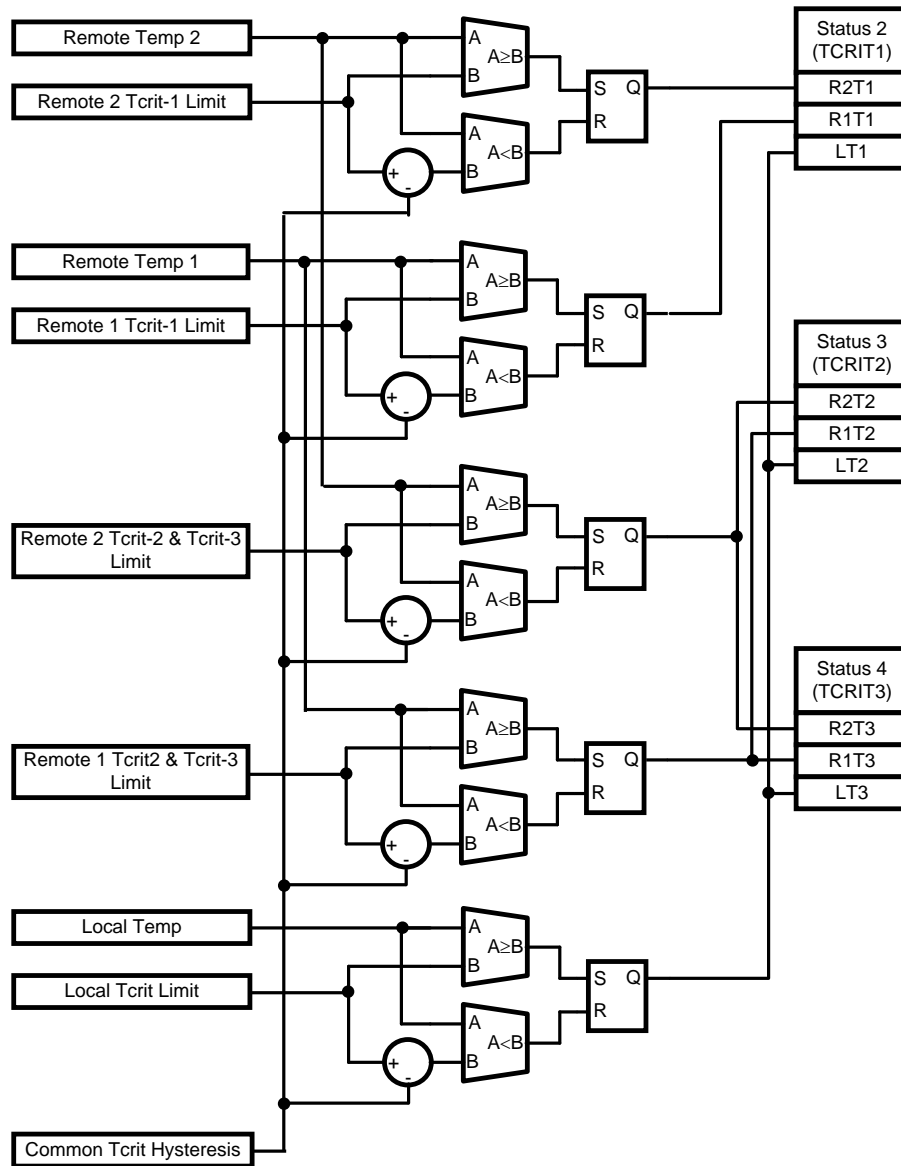
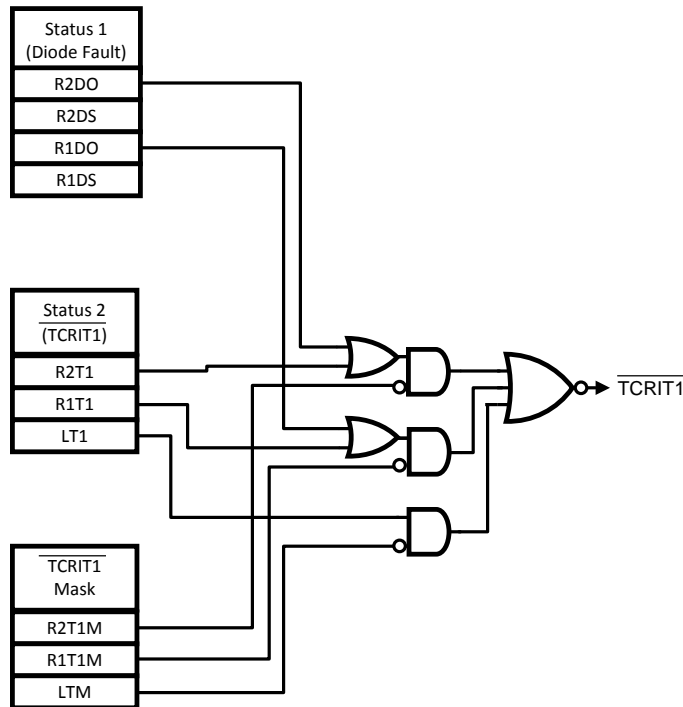
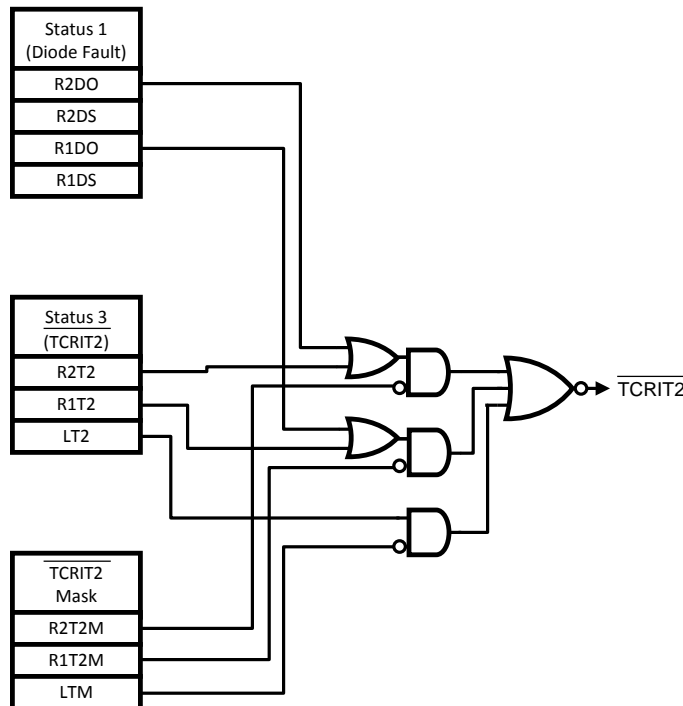

Figure 9. Temperature Comparison Logic and Status Register Simplified Diagram

a) $\overline{\text{TCRIT1}}$ Mask Register, Status Register 1 and 2, and $\overline{\text{TCRIT1}}$ output logic diagram.



b) $\overline{\text{TCRIT2}}$ Mask Register, Status Register 1 and 3, and $\overline{\text{TCRIT2}}$ output logic diagram.



c) $\overline{\text{TCRIT3}}$ Mask Register, Status Register 1 and 4, and $\overline{\text{TCRIT3}}$ output logic diagram.

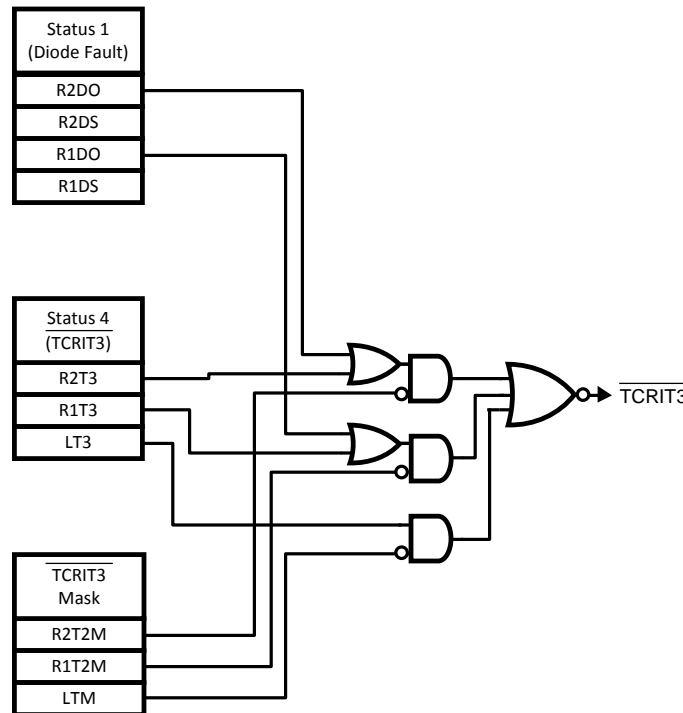

Figure 10. Logic diagrams for the $\overline{\text{TCRIT1}}$, $\overline{\text{TCRIT2}}$, and $\overline{\text{TCRIT3}}$ outputs.

If enabled, local temperature is compared to the user programmable Local Tcrit Limit Register (Default Value = 85°C). The result of this comparison is stored in Status Register 2, Status Register 3 and Status Register 4 (see Figure 9). The comparison result can trigger $\overline{\text{TCRIT1}}$ pin, $\overline{\text{TCRIT2}}$ pin or $\overline{\text{TCRIT3}}$ pin depending on the settings in the $\overline{\text{TCRIT1}}$ Mask, $\overline{\text{TCRIT2}}$ Mask and $\overline{\text{TCRIT3}}$ Mask Registers (see Figure 10). The comparison result can also be read back from the Status Register 2, Status Register 3 and Status Register 4.

If enabled, remote temperature 1 is compared to the user programmable Remote 1 Tcrit-1 Limit Register (Default Value 110°C) and Remote 1 Tcrit-2 Limit Register (Default Value = 85°C). The result of this comparison is stored in Status Register 2, Status Register 3 and Status Register 4 (see Figure 9). The comparison result can trigger $\overline{\text{TCRIT1}}$ pin, $\overline{\text{TCRIT2}}$ pin or $\overline{\text{TCRIT3}}$ pin depending on the settings in the $\overline{\text{TCRIT1}}$ Mask, $\overline{\text{TCRIT2}}$ Mask and $\overline{\text{TCRIT3}}$ Mask Registers (see Figure 10). The comparison result can also be read back from the Status Register 2, Status Register 3 and Status Register 4. The remote temperature 2 operates in a similar manner to remote temperature 1 using its associated user programmable limit registers: Remote 2 Tcrit-1 Limit Register (Default Value 110°C) and Remote 2 Tcrit-2 Limit Register (Default Value = 85°C).

Table 7. Limit assignments for each $\overline{\text{TCRIT}}$ output pin:

	$\overline{\text{TCRIT1}}$	$\overline{\text{TCRIT2}}$	$\overline{\text{TCRIT3}}$
Remote 2	Remote 2 Tcrit-1 Limit	Remote 2 Tcrit-2 Limit	Remote 2 Tcrit-2 Limit
Remote 1	Remote 1 Tcrit-1 Limit	Remote 1 Tcrit-2 Limit	Remote 1 Tcrit-2 Limit
Local	Local Tcrit Limit	Local Tcrit Limit	Local Tcrit Limit

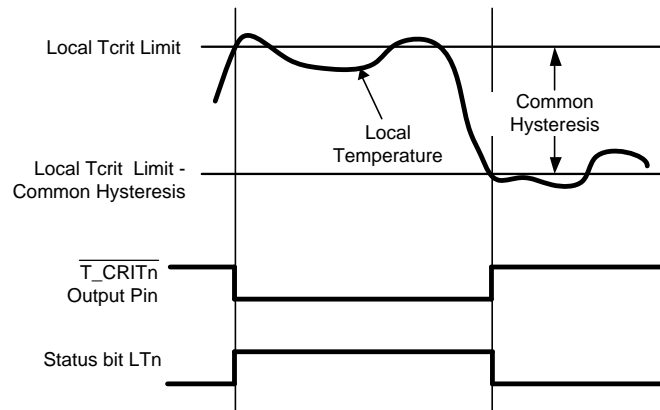

Figure 11. TCRIT response diagram (masking options not included)

The TCRIT response diagram of Figure 11 shows the local temperature interaction with the Tcrit limit and hysteresis value. As can be seen in the diagram when the local temperature exceeds the Tcrit limit register value the LTn Status bit is set and the $\overline{T_CRITn}$ output(s) is/are activated. The Status bit(s) and outputs are not deactivated until the temperature goes below the value calculated by subtracting the Common Hysteresis value programmed from the limit. This diagram mainly shows an example function of the hysteresis and is not meant to show complete function of the possible settings and options of all the TCRIT outputs and limit values.

DIODE FAULT DETECTION

The LM95213 is equipped with operational circuitry designed to detect fault conditions concerning the remote diodes. In the event that the D+ pin is detected as shorted to GND, D-, V_{DD} or D+ is floating, the Remote Temperature reading is $-128.000\text{ }^{\circ}\text{C}$ if signed format is selected and $0\text{ }^{\circ}\text{C}$ if unsigned format is selected. In addition, the appropriate status register bits RD1M or RD2M (D1 or D0) are set.

COMMUNICATING WITH THE LM95213

The data registers in the LM95213 are selected by the Command Register. At power-up the Command Register is set to "00", the location for the Read Local Temperature Register. The Command Register latches the last location it was set to. Each data register in the LM95213 falls into one of three types of user accessibility:

1. Read only
2. Write only
3. Write/Read same address

A **Write** to the LM95213 will always include the address byte and the command byte. A write to any register requires one data byte.

Reading the LM95213 can take place either of two ways:

1. If the location latched in the Command Register is correct (most of the time it is expected that the Command Register will point to one of the Read Temperature Registers because that will be the data most frequently read from the LM95213), then the read can simply consist of an address byte, followed by retrieving the data byte.
2. If the Command Register needs to be set, then an address byte, command byte, repeat start, and another address byte will accomplish a read.

The data byte has the most significant bit first. At the end of a read, the LM95213 can accept either acknowledge or No Acknowledge from the Master (No Acknowledge is typically used as a signal for the slave that the Master has read its last byte). It takes the LM95213 95 ms (typical, all channels enabled) to measure the temperature of the remote diodes and internal diode. When retrieving all 11 bits from a previous remote diode temperature measurement, the master must insure that all 11 bits are from the same temperature conversion. This may be achieved by reading the MSB register first. The LSB will be locked after the MSB is read. The LSB will be unlocked after being read. If the user reads MSBs consecutively, each time the MSB is read, the LSB associated with that temperature will be locked in and override the previous LSB value locked-in.

SMBus Timing Diagrams

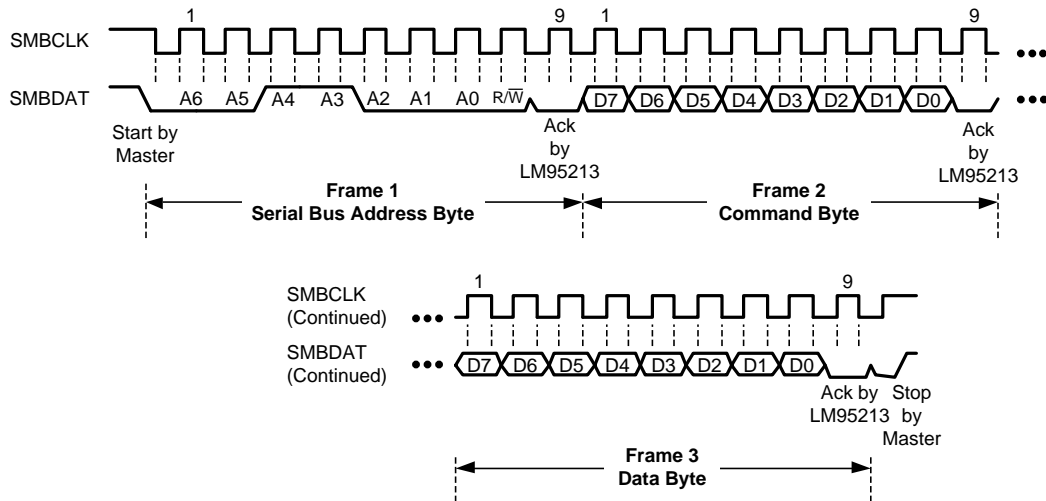

Figure 12. Serial Bus Write to the internal Command Register followed by a the Data Byte

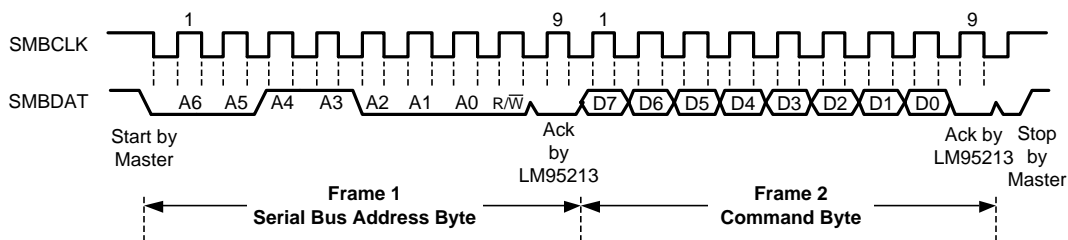

Figure 13. Serial Bus Write to the Internal Command Register

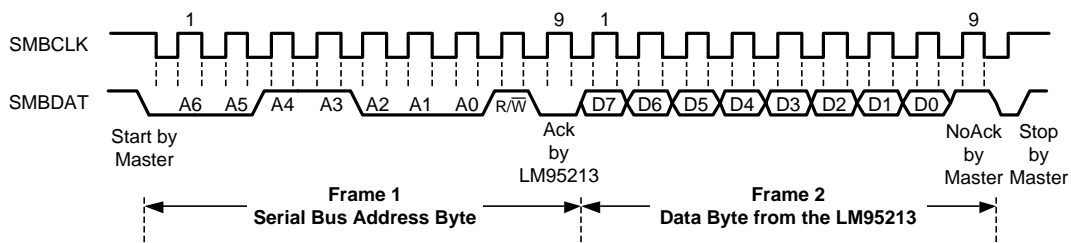

Figure 14. Serial Bus Read from a Register with the Internal Command Register preset to desired value.

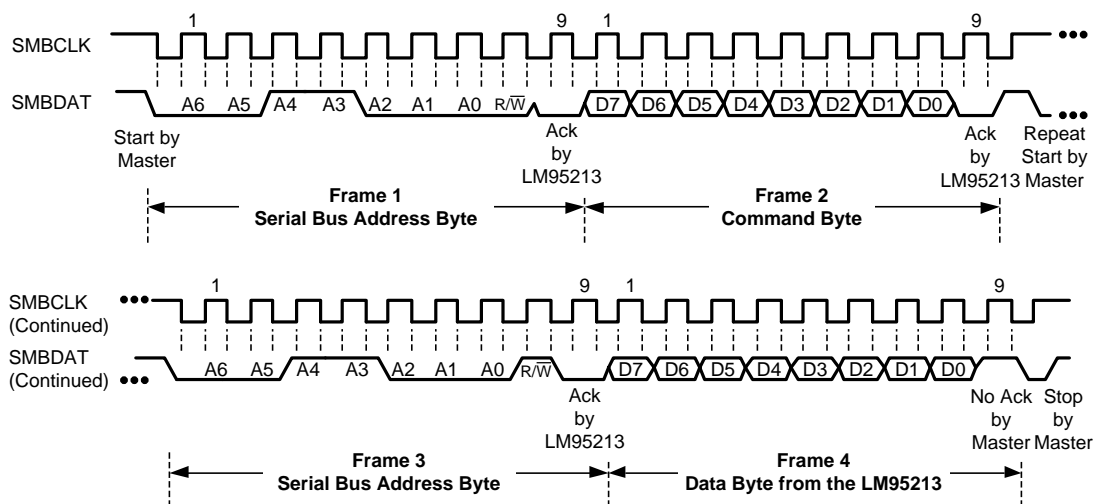

Figure 15. Serial Bus Write followed by a Repeat Start and Immediate Read

SERIAL INTERFACE RESET

In the event that the SMBus Master is RESET while the LM95213 is transmitting on the SMBDAT line, the LM95213 must be returned to a known state in the communication protocol. This may be done in one of two ways:

1. When SMBDAT is LOW, the LM95213 SMBus state machine resets to the SMBus idle state if either SMBDAT or SMBCLK are held low for more than 35ms ($t_{TIMEOUT}$). Note that according to SMBus specification 2.0 all devices are to timeout when either the SMBCLK or SMBDAT lines are held low for 25-35ms. Therefore, to insure a timeout of all devices on the bus the SMBCLK or SMBDAT lines must be held low for at least 35ms.
2. When SMBDAT is HIGH, have the master initiate an SMBus start. The LM95213 will respond properly to an SMBus start condition at any point during the communication. After the start the LM95213 will expect an SMBus Address address byte.

ONE-SHOT CONVERSION

The One-Shot register is used to initiate a round of conversions and comparisons when the device is in standby mode, after which the device returns to standby. This is not a data register and it is the write operation that causes the one-shot conversion. The data written to this address is irrelevant and is not stored. A zero will always be read from this register. All the channels that are enabled in the Channel Enable Register will be converted once and the $\overline{TCRIT1}$, $\overline{TCRIT2}$ and $\overline{TCRIT3}$ pins will reflect the comparison results based on this round of conversion results of the channels that are not masked.

LM95213 Registers

Command register selects which registers will be read from or written to. Data for this register should be transmitted during the Command Byte of the SMBus write communication.

P7	P6	P5	P4	P3	P2	P1	P0
Command Byte							

P0-P7: Command

Table 8. Register Summary

Register Name	Command Byte (Hex)	Read/Write	D7	D6	D5	D4	D3	D2	D1	D0	POR Default (Hex)
Local Temp MSB	0x10	RO	SIGN	64	32	16	8	4	2	1	–
Local Temp LSB	0x20	RO	1/2	1/4	1/8	0	0	0	0	0	–
Remote Temp 1 MSB – Signed	0x11	RO	SIGN	64	32	16	8	4	2	1	–
Remote Temp 1 LSB – Signed, Digital Filter Off	0x21	RO	1/2	1/4	1/8	0	0	0	0	0	–
Remote Temp 1 LSB – Signed, Digital Filter On						1/16	1/32				
Remote Temp 2 MSB – Signed	0x12	RO	SIGN	64	32	16	8	4	2	1	–
Remote Temp 2 LSB – Signed, Digital Filter Off	0x22	RO	1/2	1/4	1/8	0	0	0	0	0	–
Remote Temp 2 LSB – Signed, Digital Filter On						1/16	1/32				
Remote Temp 1 MSB – Unsigned	0x19	RO	128	64	32	16	8	4	2	1	–
Remote Temp 1 LSB – Unsigned, Digital Filter Off	0x29	RO	1/2	1/4	1/8	0	0	0	0	0	–
Remote Temp 1 LSB – Unsigned, Digital Filter On						1/16	1/32				
Remote Temp 2 MSB – Unsigned	0x1A	RO	128	64	32	16	8	4	2	1	–
Remote Temp 2 LSB – Unsigned, Digital Filter Off	0x2A	RO	1/2	1/4	1/8	0	0	0	0	0	–
Remote Temp 2 LSB – Unsigned, Digital Filter On						1/16	1/32				
Remote 1 Offset	0x31	R/W	SIGN	32	16	8	4	2	1	1/2	0x00
Remote 2 Offset	0x32	R/W	SIGN	32	16	8	4	2	1	1/2	0x00
Configuration	0x03	R/W	–	STBY	–	–	–	–	–	–	0x00
Conversion Rate	0x04	R/W	–	–	–	–	–	–	CR1	CR0	0x02
Channel Conversion Enable	0x05	R/W	–	–	–	–	–	R2CE	R1CE	LCE	0x1F
Filter Setting	0x06	R/W	–	–	–	–	R2F1	R2F0	R1F1	R1F0	0x0F
1-shot	0x0F	WO	–	–	–	–	–	–	–	–	–
Common Status Register	0x02	RO	BUSY	NR	–	–	SR4F	SR3F	SR2F	SR1F	0x00
Status 1 (Diode Fault)	0x07	RO	–	–	–	–	R2DO	R2DS	R1DO	R1DS	–
Status 2 ($\overline{\text{TCRIT1}}$)	0x08	RO	–	–	–	–	–	R2T1	R1T1	LT1	–
Status 3 ($\overline{\text{TCRIT2}}$)	0x09	RO	–	–	–	–	–	R2T2	R1T2	LT2	–
Status 4 ($\overline{\text{TCRIT3}}$)	0x0A	RO	–	–	–	–	–	R2T3	R1T3	LT3	–
TCRIT1 Mask	0x0C	R/W	–	–	–	–	–	R2T1M	R1T1M	LTM	0x01
TCRIT2 Mask	0x0D	R/W	–	–	–	–	–	R2T2M	R1T2M	LTM	0x00
TCRIT3 Mask	0x0E	R/W	–	–	–	–	–	R2T2M	R1T2M	LTM	0x07
Local Tcrit Limit	0x40	R/W	0	64	32	16	8	4	2	1	0x55
Remote 1 Tcrit-1 Limit	0x41	R/W	128	64	32	16	8	4	2	1	0x6E
Remote 2 Tcrit-1 Limit	0x42	R/W	128	64	32	16	8	4	2	1	0x6E
Remote 1 Tcrit-2 and Tcrit-3 Limit	0x49	R/W	128	64	32	16	8	4	2	1	0x55
Remote 2 Tcrit-2 and Tcrit-3 Limit	0x4A	R/W	128	64	32	16	8	4	2	1	0x55
Common Tcrit Hysteresis	0x5A	R/W	0	0	0	16	8	4	2	1	0x0A
Manufacturer ID	0xFE	RO	0	0	0	0	0	0	0	1	0x01
Revision ID	0xFF	RO	1	0	0	0	0	1	0	1	0x8B

VALUE REGISTERS

For data synchronization purposes, the MSB register should be read first if the user wants to read both MSB and LSB registers. The LSB will be locked after the MSB is read. The LSB will be unlocked after being read. If the user reads MSBs consecutively, each time the MSB is read, the LSB associated with that temperature will be locked in and override the previous LSB value locked-in.

Local Value Registers

Register Name	Command Byte (Hex)	Read/Write	D7	D6	D5	D4	D3	D2	D1	D0	POR Default (Hex)
Local Temp MSB	0x10	RO	SIGN	64	32	16	8	4	2	1	–
Local Temp LSB	0x20	RO	1/2	1/4	1/8	0	0	0	0	0	–

Bit(s)	Bit Name	Read/Write	Description
7	SIGN	RO	Sign bit
6	64	RO	bit weight 64°C
5	32	RO	bit weight 32°C
4	16	RO	bit weight 16°C
3	8	RO	bit weight 8°C
2	4	RO	bit weight 4°C
1	2	RO	bit weight 2°C
0	1	RO	bit weight 1°C

The Local temperature MSB value register range is +127°C to –128°C. The value programmed in this register is used to determine a local temperature error event.

Bit(s)	Bit Name	Read/Write	Description
7	1/2	RO	bit weight 1/2°C (0.5°C)
6	1/4	RO	bit weight 1/4°C (0.25°C)
5	1/8	RO	bit weight 1/8°C (0.125°C)
4-0	0	RO	Reserved – will report "0" when read.

The Local Limit register range is 0°C to 127°C. The value programmed in this register is used to determine a local temperature error event.

Remote Temperature Value Registers with Signed Format

Register Name	Command Byte (Hex)	Read/Write	D7	D6	D5	D4	D3	D2	D1	D0	POR Default (Hex)
Remote Temp 1 MSB – Signed	0x11	RO	SIGN	64	32	16	8	4	2	1	–
Remote Temp 1 LSB – Signed, Digital Filter Off	0x21	RO	1/2	1/8	0	0	0	0	0	0	–
Remote Temp 1 LSB – Signed, Digital Filter On					1/16	1/32					
Remote Temp 2 MSB – Signed	0x12	RO	SIGN	64	32	16	8	4	2	1	–
Remote Temp 2 LSB – Signed, Digital Filter Off	0x22	RO	1/2	1/8	0	0	0	0	0	0	–
Remote Temp 2 LSB – Signed, Digital Filter On					1/16	1/32					

The Local temperature MSB value register range is +127°C to –128°C. The value programmed in this register is used to determine a local temperature error event.

Bit(s)	Bit Name	Read/Write	Description
7	SIGN	RO	Sign bit
6	64	RO	bit weight 64°C

Bit(s)	Bit Name	Read/Write	Description
5	32	RO	bit weight 32°C
4	16	RO	bit weight 16°C
3	8	RO	bit weight 8°C
2	4	RO	bit weight 4°C
1	2	RO	bit weight 2°C
0	1	RO	bit weight 1°C

Bit(s)	Bit Name	Read/Write	Description
7	1/2	RO	bit weight 1/2°C (0.5°C)
6	1/4	RO	bit weight 1/4°C (0.25°C)
5	1/8	RO	bit weight 1/8°C (0.125°C)
4	0 or 1/16	RO	When the digital filter is disabled this bit will always read "0". When the digital filter is enabled this bit will report 1/16°C (0.0625°C) bit state.
3	0 or 1/32	RO	When the digital filter is disabled this bit will always read "0". When the digital filter is enabled this bit will report 1/32°C (0.03125°C) bit state.
2-0	0	RO	Reserved – will report "0" when read.

Remote Temperature Value Registers with Unsigned Format

Register Name	Command Byte (Hex)	Read/Write	D7	D6	D5	D4	D3	D2	D1	D0	POR Default (Hex)
Remote Temp 1 MSB – Unsigned	0x19	RO	128	64	32	16	8	4	2	1	–
Remote Temp 1 LSB – Unsigned, Digital Filter Off	0x29	RO	1/2	1/8	0	0	0	0	0	0	–
Remote Temp 1 LSB – Unsigned, Digital Filter On					1/16	1/32					
Remote Temp 2 MSB – Unsigned	0x1A	RO	128	64	32	16	8	4	2	1	–
Remote Temp 2 LSB – Unsigned, Digital Filter Off	0x2A	RO	1/2	1/8	0	0	0	0	0	0	–
Remote Temp 2 LSB – Unsigned, Digital Filter On					1/16	1/32					

Bit(s)	Bit Name	Read/Write	Description
7	SIGN	RO	bit weight 128°C
6	64	RO	bit weight 64°C
5	32	RO	bit weight 32°C
4	16	RO	bit weight 16°C
3	8	RO	bit weight 8°C
2	4	RO	bit weight 4°C
1	2	RO	bit weight 2°C
0	1	RO	bit weight 1°C

Bit(s)	Bit Name	Read/Write	Description
7	1/2	RO	bit weight 1/2°C (0.5°C)
6	1/4	RO	bit weight 1/4°C (0.25°C)
5	1/8	RO	bit weight 1/8°C (0.125°C)
4	0 or 1/16	RO	When the digital filter is disabled this bit will always read "0". When the digital filter is enabled this bit will report 1/16°C (0.0625°C) bit state.

Bit(s)	Bit Name	Read/Write	Description
3	0 or 1/32	RO	When the digital filter is disabled this bit will always read "0". When the digital filter is enabled this bit will report 1/32°C (0.03125°C) bit state.
2-0	0	RO	Reserved – will report "0" when read.

DIODE CONFIGURATION REGISTERS

Remote 1-2 Offset

Register Name	Command Byte (Hex)	Read/Write	D7	D6	D5	D4	D3	D2	D1	D0	POR Default (Hex)
Remote 1 Offset	0x31	R/W	SIGN	32	16	8	4	2	1	1/2	0x00
Remote 2 Offset	0x32	R/W	SIGN	32	16	8	4	2	1	1/2	0x00

Bit(s)	Bit Name	Read/Write	Description
7	SIGN	R/W	Sign bit
6	32	R/W	bit weight 32°C
5	16	R/W	bit weight 16°C
4	8	R/W	bit weight 8°C
3	4	R/W	bit weight 4°C
2	2	R/W	bit weight 2°C
1	1	R/W	bit weight 1°C
0	1/2	R/W	bit weight 1/2°C (0.5°C)

All registers have 2's complement format. The offset range for each remote is +63.5°C/-64°C. The value programmed in this register is directly added to the actual reading of the ADC and the modified number is reported in the remote value registers.

CONFIGURATION REGISTERS

Main Configuration Register

Register Name	Command Byte (Hex)	Read/Write	D7	D6	D5	D4	D3	D2	D1	D0	POR Default (Hex)
Configuration	0x03	R/W	–	STBY	–	–	–	–	–	–	0x00

Bit(s)	Bit Name	Read/Write	Description
7	–	RO	Reserved will report "0" when read.
6	STBY	R/W	Software Standby 1 – standby (when in this mode one conversion sequence can be initiated by writing to the one-shot register) 0 – active/converting
5–0	–	RO	Reserved – will report "0" when read.

Conversion Rate Register

Register Name	Command Byte (Hex)	Read/Write	D7	D6	D5	D4	D3	D2	D1	D0	POR Default (Hex)
Conversion Rate	0x04	R/W	–	–	–	–	–	–	CR1	CR0	0x02

Bit(s)	Bit Name	Read/Write	Description										
7-2	–	RO	Reserved – will report "0" when read.										
1-0	CR[1:0]	R/W	Conversion rate control bits modify the time interval for conversion of the channels enabled. The channels enabled are converted sequentially then standby mode enabled for the remainder of the time interval.										
			<table border="1"> <thead> <tr> <th>CR[1:0]</th> <th>Conversion Rate</th> </tr> </thead> <tbody> <tr> <td>00</td> <td>continuous (30 ms to 104 ms)</td> </tr> <tr> <td>01</td> <td>0.364 s</td> </tr> <tr> <td>10</td> <td>1s</td> </tr> <tr> <td>11</td> <td>2.5 s</td> </tr> </tbody> </table>	CR[1:0]	Conversion Rate	00	continuous (30 ms to 104 ms)	01	0.364 s	10	1s	11	2.5 s
CR[1:0]	Conversion Rate												
00	continuous (30 ms to 104 ms)												
01	0.364 s												
10	1s												
11	2.5 s												

Channel Conversion Enable

When a conversion is disabled for a particular channel it is skipped. The continuous conversion rate is effected all other conversion rates are not effected as extra standby time is inserted in order to compensate. See [Conversion Rate Register](#) description.

Register Name	Command Byte (Hex)	Read/Write	D7	D6	D5	D4	D3	D2	D1	D0	POR Default (Hex)
Channel Conversion Enable	0x05	R/W	–	–	–	–	–	R2CE	R1CE	LCE	0x1F

Bit(s)	Bit Name	Read/Write	Description
7–3	–	RO	Reserved – will report "0" when read.
2	R2CE	R/W	Remote 2 Temperature Conversion Enable 1– Remote 2 temp conversion enabled 0– Remote 2 temp conversion disabled
1	R1CE	R/W	Remote 1 Temperature Conversion Enable 1– Remote 1 temp conversion enabled 0– Remote 1 temp conversion disabled
0	LCE	R/W	Local Temperature Conversion Enable 1– Local temp conversion enabled 0– Local temp conversion disabled

Filter Setting

Register Name	Command Byte (Hex)	Read/Write	D7	D6	D5	D4	D3	D2	D1	D0	POR Default (Hex)
Filter Setting	0x06	R/W	–	–	–	–	R2F1	R2F0	R1F1	R1F0	0x0F

Bit(s)	Bit Name	Read/Write	Description	
7–4	–	RO	Reserved – will report "0" when read.	
3–2	R2F[1:0]	R/W	Remote Channel 2 Filter Enable Bits	
			R2F[1:0]	Digital Filter State
			00	disable all digital filtering
			01	enable basic filter
			10	reserved (do not use)
	11	enable enhanced filter		
1–0	R1F[1:0]	R/W	Remote Channel 1 Filter Enable	
			R1F[1:0]	Filter State
			00	disable all digital filtering
			01	enable basic filter
			10	reserved (do not use)
	11	enable enhanced filter		

1-Shot

Register Name	Command Byte (Hex)	Read/Write	D7	D6	D5	D4	D3	D2	D1	D0	POR Default (Hex)
1-Shot	0x0F	WO	–	–	–	–	–	–	–	–	–

Bit(s)	Bit Name	Read/Write	Description
7–0	–	WO	Writing to this register activates one conversion for all the enabled channels if the chip is in standby mode (i.e. standby bit = 1). The actual data written does not matter and is not stored.

STATUS REGISTERS

Common Status Register

Register Name	Command Byte (Hex)	Read/Write	D7	D6	D5	D4	D3	D2	D1	D0	POR Default (Hex)
Common Status Register	0x02	RO	BUSY	NR	–	–	SR4F	SR3F	SR2F	SR1F	0x00

Bit(s)	Bit Name	Read/Write	Description
7	BUSY	RO	Busy bit (device converting)
6	NR	RO	Not Ready bit (30 ms), indicates power up initialization sequence is in progress
5–4	–	RO	Reserved – will report "0" when read.
3	SR4F	RO	Status Register 4 Flag: 1 – indicates that Status Register 4 has at least one bit set 0 – indicates that all of Status Register 4 bits are cleared
2	SR3F	RO	Status Register 3 Flag: 1 – indicates that Status Register 3 has at least one bit set 0 – indicates that all of Status Register 3 bits are cleared
1	SR2F	RO	Status Register 2 Flag: 1 – indicates that Status Register 2 has at least one bit set 0 – indicates that all of Status Register 2 bits are cleared
0	SR1F	RO	Status Register 1 Flag: 1 – indicates that Status Register 1 has at least one bit set 0 – indicates that all of Status Register 1 bits are cleared

Status 1 Register (Diode Fault)

Status fault bits for open or shorted diode (i.e. Short Fault: D+ shorted to Ground or D-; Open Fault: D+ shorted to V_{DD} , or floating). During fault conditions the temperature reading is 0 °C if unsigned value registers are read or -128.000 °C if signed value registers are read.

Register Name	Command Byte (Hex)	Read/Write	D7	D6	D5	D4	D3	D2	D1	D0	POR Default (Hex)
Status 1 (Diode Fault)	0x07	RO	0	0	0	0	R2DO	R2DS	R1DO	R1DS	-

Bit(s)	Bit Name	Read/Write	Description
7-4	-	RO	Reserved – will report "0" when read.
3	R2DO	RO	Remote 2 diode open fault status: 1 – indicates that remote 2 diode has an "open" fault 0 – indicates that remote 2 diode does not have an "open" fault
2	R2DS	RO	Remote 2 diode short fault status: 1 – indicates that remote 2 diode has a "short" fault 0 – indicates that remote 2 diode does not have a "short" fault
1	R1DO	RO	Remote 1 diode open fault status: 1 – indicates that remote 1 diode has an "open" fault 0 – indicates that remote 1 diode does not have an "open" fault
0	R1DS	RO	Remote 1 diode short fault status: 1 – indicates that remote 1 diode has a "short" fault 0 – indicates that remote 1 diode does not have a "short" fault

Status 2 ($\overline{\text{TCRIT1}}$)

Status bits for $\overline{\text{TCRIT1}}$. When one or more of these bits are set and if not masked the $\overline{\text{TCRIT1}}$ output will activate. $\overline{\text{TCRIT1}}$ will deactivate when all these bits are cleared.

Register Name	Command Byte (Hex)	Read/Write	D7	D6	D5	D4	D3	D2	D1	D0	POR Default (Hex)
Status 2 ($\overline{\text{TCRIT1}}$)	0x08	RO	-	-	-	-	-	R2T1	R1T1	LT1	-

Bit(s)	Bit Name	Read/Write	Description
7-3	-	RO	Reserved – will report "0" when read.
2	R2T1	RO	Remote 2 Tcrit-1 Status: 1 – indicates that remote 2 reading is greater than or equal to the value set in Remote 2 Tcrit-1 Limit register 0 – indicates that that remote 2 reading is less than the value set in Remote 2 Tcrit-1 Limit register minus the Common Hysteresis value
1	R1T1	RO	Remote 1 Tcrit-1 Status: 1 – indicates that remote 1 reading is greater than or equal to the value set in Remote 1 Tcrit-1 Limit register 0 – indicates that that remote 1 reading is less than the value set in Remote 1 Tcrit-1 Limit register minus the Common Hysteresis value
0	LT1	RO	Local Tcrit Status: 1 – indicates that local reading is greater than or equal to the value set in Local Tcrit Limit register 0 – indicates that local reading is less than the value set in Local Tcrit Limit register minus the Common Hysteresis value

Status 3 ($\overline{\text{TCRIT2}}$)

Status bits for $\overline{\text{TCRIT2}}$. When one or more of these bits are set and if not masked the $\overline{\text{TCRIT2}}$ output will activate. $\overline{\text{TCRIT2}}$ will deactivate when all these bits are cleared.

Register Name	Command Byte (Hex)	Read/Write	D7	D6	D5	D4	D3	D2	D1	D0	POR Default (Hex)
Status 3 ($\overline{\text{TCRIT2}}$)	0x09	RO	–	–	–	–	–	R2T2	R1T2	LT2	–

Bit(s)	Bit Name	Read/Write	Description
7–3	-	RO	Reserved – will report "0" when read.
2	R2T2	RO	Remote 2 Tcrit-2 Status: 1 – indicates that remote 2 reading is greater than or equal to the value set in Remote 2 Tcrit-2 Limit register 0 – indicates that that remote 2 reading is less than the value set in Remote 2 Tcrit-2 Limit register minus the Common Hysteresis value
1	R1T2	RO	Remote 1 Tcrit-2 Status: 1 – indicates that remote 1 reading is greater than or equal to the value set in Remote 1 Tcrit-2 Limit register 0 – indicates that that remote 1 reading is less than the value set in Remote 1 Tcrit-2 Limit register minus the Common Hysteresis value
0	LT2	RO	Local Tcrit Status: 1 – indicates that local reading is greater than or equal to the value set in Local Tcrit Limit register 0 – indicates that local reading is less than the value set in Local Tcrit Limit register minus the Common Hysteresis value

Status 4 ($\overline{\text{TCRIT3}}$)

Status bits for $\overline{\text{TCRIT3}}$. When one or more of these bits are set and if not masked the $\overline{\text{TCRIT3}}$ output will activate. $\overline{\text{TCRIT3}}$ will deactivate when all these bits are cleared.

Register Name	Command Byte (Hex)	Read/Write	D7	D6	D5	D4	D3	D2	D1	D0	POR Default (Hex)
Status 4 ($\overline{\text{TCRIT3}}$)	0x0A	RO	–	–	–	–	–	R2T3	R1T3	LT3	–

Bit(s)	Bit Name	Read/Write	Description
7–3	-	RO	Reserved – will report "0" when read.
2	R2T3	RO	Remote 2 Tcrit-2 Status: 1 – indicates that remote 2 reading is greater than or equal to the value set in Remote 2 Tcrit-2 Limit register 0 – indicates that that remote 2 reading is less than the value set in Remote 2 Tcrit-2 Limit register minus the Common Hysteresis value
1	R1T3	RO	Remote 1 Tcrit-2 Status: 1 – indicates that remote 1 reading is greater than or equal to the value set in Remote 1 Tcrit-2 Limit register 0 – indicates that that remote 1 reading is less than the value set in Remote 1 Tcrit-2 Limit register minus the Common Hysteresis value
0	LT3	RO	Local Tcrit Status: 1 – indicates that local reading is greater than or equal to the value set in Local Tcrit Limit register 0 – indicates that local reading is less than the value set in Local Tcrit Limit register minus the Common Hysteresis value

MASK REGISTERS

TCRIT1 Mask Register

The mask bits in this register allow control over which error events propagate to the $\overline{\text{TCRIT1}}$ pin.

Register Name	Command Byte (Hex)	Read/Write	D7	D6	D5	D4	D3	D2	D1	D0	POR Default (Hex)
$\overline{\text{TCRIT1}}$ Mask	0x0C	R/W	–	–	–	–	–	R2T1 M	R1T1 M	LTM	0x01

Bit(s)	Bit Name	Read/Write	Description
7-3	–	RO	Reserved – will report "0" when read.
2	R2T1M	R/W	Remote 2 Tcrit-1 Mask: 1 – prevents the remote 2 temperature error event from propagating to the $\overline{\text{TCRIT1}}$ pin 0 – allows the remote 2 temperature error event to propagate to the $\overline{\text{TCRIT1}}$ pin
1	R1T1M	R/W	Remote 1 Tcrit-1 Mask: 1 – prevents the remote 1 temperature error event from propagating to the $\overline{\text{TCRIT1}}$ pin 0 – allows the remote 1 temperature error event to propagate to the $\overline{\text{TCRIT1}}$ pin
0	LTM	R/W	Local Tcrit Mask: 1 – prevents the local temperature error event from propagating to the $\overline{\text{TCRIT1}}$ pin 0 – allows the local temperature error event to propagate to the $\overline{\text{TCRIT1}}$ pin

TCRIT2 Mask Registers

Register Name	Command Byte (Hex)	Read/Write	D7	D6	D5	D4	D3	D2	D1	D0	POR Default (Hex)
$\overline{\text{TCRIT2}}$ Mask	0x0D	R/W	–	–	–	–	–	R2T2 M	R1T2 M	LTM	0x00

Bit(s)	Bit Name	Read/Write	Description
7-3	–	RO	Reserved – will report "0" when read.
2	R2T2M	R/W	Remote 2 Tcrit-2 Mask: 1 – prevents the remote 2 temperature error event from propagating to the $\overline{\text{TCRIT2}}$ pin 0 – allows the remote 2 temperature error event to propagate to the $\overline{\text{TCRIT2}}$ pin
1	R1T2M	R/W	Remote 1 Tcrit-2 Mask: 1 – prevents the remote 1 temperature error event from propagating to the $\overline{\text{TCRIT2}}$ pin 0 – allows the remote 1 temperature error event to propagate to the $\overline{\text{TCRIT2}}$ pin
0	LTM	R/W	Local Tcrit Mask: 1 – prevents the local temperature error event from propagating to the $\overline{\text{TCRIT2}}$ pin 0 – allows the local temperature error event to propagate to the $\overline{\text{TCRIT2}}$ pin

TCRIT3 Mask Register

The mask bits in this register allow control over which error events propagate to the $\overline{\text{TCRIT3}}$ pin.

Register Name	Command Byte (Hex)	Read/Write	D7	D6	D5	D4	D3	D2	D1	D0	POR Default (Hex)
$\overline{\text{TCRIT3}}$ Mask	0x0E	R/W	–	–	–	–	–	R2T2 M	R1T2 M	LTM	0x07

Bit(s)	Bit Name	Read/Write	Description
7-3	–	RO	Reserved – will report "0" when read.
2	R2T2M	R/W	Remote 2 Tcrit-2 Mask: 1 – prevents the remote 2 temperature error event from propagating to the $\overline{\text{TCRIT3}}$ pin 0 – allows the remote 2 temperature error event to propagate to the $\overline{\text{TCRIT3}}$ pin
1	R1T2M	R/W	Remote 1 Tcrit-2 Mask: 1 – prevents the remote 1 temperature error event from propagating to the $\overline{\text{TCRIT3}}$ pin 0 – allows the remote 1 temperature error event to propagate to the $\overline{\text{TCRIT3}}$ pin
0	LTM	R/W	Local Tcrit Mask: 1 – prevents the local temperature error event from propagating to the $\overline{\text{TCRIT3}}$ pin 0 – allows the local temperature error event to propagate to the $\overline{\text{TCRIT3}}$ pin

LIMIT REGISTERS

Local Limit Register

The Local Limit register range is 0°C to 127°C. The value programmed in this register is used to determine a local temperature error event.

Register Name	Command Byte (Hex)	Read/Write	D7	D6	D5	D4	D3	D2	D1	D0	POR Default (Hex)
Local Tcrit Limit	0x40	R/W	0	64	32	16	8	4	2	1	0x55

Bit(s)	Bit Name	Read/Write	Description
7	0	R0	Read only bit will always report "0".
6	64	R/W	bit weight 64°C
5	32	R/W	bit weight 32°C
4	16	R/W	bit weight 16°C
3	8	R/W	bit weight 8°C
2	4	R/W	bit weight 4°C
1	2	R/W	bit weight 2°C
0	1	R/W	bit weight 1°C

Remote Limit Registers

The range for these registers is 0°C to 255°C.

Register Name	Command Byte (Hex)	Read/Write	D7	D6	D5	D4	D3	D2	D1	D0	POR Default (Hex)
Remote 1 Tcrit-1 Limit (used by $\overline{\text{TCRIT1}}$ error events)	0x41	R/W	128	64	32	16	8	4	2	1	0x6E
Remote 2 Tcrit-1 Limit (used by $\overline{\text{TCRIT1}}$ error events)	0x42	R/W	128	64	32	16	8	4	2	1	0x6E
Remote 1 Tcrit-2 and Tcrit3 Limit (used by $\overline{\text{TCRIT2}}$ and $\overline{\text{TCRIT3}}$ error events)	0x49	R/W	128	64	32	16	8	4	2	1	0x55
Remote 2 Tcrit-2 and Tcrit3 Limit (used by $\overline{\text{TCRIT2}}$ and $\overline{\text{TCRIT3}}$ error events)	0x4A	R/W	128	64	32	16	8	4	2	1	0x55

Bit(s)	Bit Name	Read/Write	Description
7	128	R/W	bit weight 128°C
6	64	R/W	bit weight 64°C
5	32	R/W	bit weight 32°C

Bit(s)	Bit Name	Read/Write	Description
4	16	R/W	bit weight 16°C
3	8	R/W	bit weight 8°C
2	4	R/W	bit weight 4°C
1	2	R/W	bit weight 2°C
0	1	R/W	bit weight 1°C

Table 9.

Output Pin	Remote 2	Remote 1	Local
$\overline{\text{TCRIT1}}$	Remote 2 Tcrit-1 Limit	Remote 1 Tcrit-1 Limit	Local Tcrit Limit
$\overline{\text{TCRIT2}}$	Remote 2 Tcrit-2 Limit	Remote 1 Tcrit-2 Limit	Local Tcrit Limit
$\overline{\text{TCRIT3}}$	Remote 2 Tcrit-2 Limit	Remote 1 Tcrit-2 Limit	Local Tcrit Limit

Common Tcrit Hysteresis Register

The hysteresis register range is 0°C to 32°C. The value programmed in this register is used to modify all the limit values for decreasing temperature.

Register Name	Command Byte (Hex)	Read/Write	D7	D6	D5	D4	D3	D2	D1	D0	POR Default (Hex)
Common Tcrit Hysteresis	0x5A	R/W	0	0	0	16	8	4	2	1	0x0A

Bit(s)	Bit Name	Read/Write	Description
7	0	RO	Read only bit will always report "0".
6	0	RO	Read only bit will always report "0".
5	0	RO	Read only bit will always report "0".
4	16	R/W	bit weight 16°C
3	8	R/W	bit weight 8°C
2	4	R/W	bit weight 4°C
1	2	R/W	bit weight 2°C
0	1	R/W	bit weight 1°C

IDENTIFICATION REGISTERS

Register Name	Command Byte (Hex)	Read/Write	D7	D6	D5	D4	D3	D2	D1	D0	POR Default (Hex)
Manufacturer ID	0xFE	RO	0	0	0	0	0	0	0	1	0x01
Revision ID	0xFF	RO	1	0	0	0	1	0	1	1	0x8B

Applications Hints

The LM95213 can be applied easily in the same way as other integrated-circuit temperature sensors, and its remote diode sensing capability allows it to be used in new ways as well. It can be soldered to a printed circuit board, and because the path of best thermal conductivity is between the die and the pins, its temperature will effectively be that of the printed circuit board lands and traces soldered to the LM95213's pins. This presumes that the ambient air temperature is almost the same as the surface temperature of the printed circuit board; if the air temperature is much higher or lower than the surface temperature, the actual temperature of the LM95213 die will be at an intermediate temperature between the surface and air temperatures. Again, the primary thermal conduction path is through the leads, so the circuit board temperature will contribute to the die temperature much more strongly than will the air temperature.

To measure temperature external to the LM95213's die, incorporates remote diode sensing technology. This diode can be located on the die of a target IC, allowing measurement of the IC's temperature, independent of the LM95213's temperature. A discrete diode can also be used to sense the temperature of external objects or ambient air. Remember that a discrete diode's temperature will be affected, and often dominated, by the temperature of its leads. Most silicon diodes do not lend themselves well to this application. It is recommended that an MMBT3904 transistor base emitter junction be used with the collector tied to the base.

The LM95213 can measure a diode-connected transistor such as the MMBT3904 or the thermal diode found in an AMD processor or FPGA. The LM95213 has been optimized to measure the remote thermal diode integrated in a typical MMBT3904 transistor. The offset register can be used to calibrate for other thermal diodes easily. The LM9513 does not include TruTherm™ technology that allows sensing of sub-micron geometry process thermal diodes. For this application the LM95233 would be better suited.

The LM95233 has been specifically optimized to measure the remote thermal diode integrated in a typical Intel processor on 65nm or 90 nm process or an MMBT3904 transistor. Using the Remote Diode Model Select register found in the LM95233 any of the two remote inputs can be optimized for a typical Intel processor on 65nm or 90nm process or an MMBT3904.

DIODE NON-IDEALITY

Diode Non-Ideality Factor Effect on Accuracy

When a transistor is connected as a diode, the following relationship holds for variables V_{BE} , T and I_F :

$$I_F = I_S \times \left[e^{\left(\frac{V_{BE}}{\eta \times V_t} \right)} - 1 \right]$$

where

- $V_t = \frac{kT}{q}$
- $q = 1.6 \times 10^{-19}$ Coulombs (the electron charge),
- T = Absolute Temperature in Kelvin
- $k = 1.38 \times 10^{-23}$ joules/K (Boltzmann's constant),
- η is the non-ideality factor of the process the diode is manufactured on,
- I_S = Saturation Current and is process dependent,
- I_F = Forward Current through the base-emitter junction
- V_{BE} = Base-Emitter Voltage drop

In the active region, the -1 term is negligible and may be eliminated, yielding the following equation

$$I_F = I_S \times \left[e^{\left(\frac{V_{BE}}{\eta \times V_t} \right)} \right] \tag{2}$$

In [Equation 2](#), η and I_S are dependant upon the process that was used in the fabrication of the particular diode. By forcing two currents with a very controlled ratio (I_{F2} / I_{F1}) and measuring the resulting voltage difference, it is possible to eliminate the I_S term. Solving for the forward voltage difference yields the relationship:

$$\Delta V_{BE} = \eta \times \left(\frac{kT}{q} \right) \times \ln \left(\frac{I_{F2}}{I_{F1}} \right) \tag{3}$$

Solving [Equation 3](#) for temperature yields:

$$T = \frac{q \times \Delta V_{BE}}{\eta \times k \times \ln \left(\frac{I_{F2}}{I_{F1}} \right)} \tag{4}$$

Equation 4 holds true when a diode connected transistor such as the MMBT3904 is used. When this “diode” equation is applied to an integrated diode such as a processor transistor with its collector tied to GND as shown in Figure 16 it will yield a wide non-ideality spread. This wide non-ideality spread is not due to true process variation but due to the fact that Equation 4 is an approximation.

National invented TruTherm beta cancellation technology uses the transistor equation, Equation 5, which is a more accurate representation of the topology of the thermal diode found in some sub-micron FPGAs or processors.

$$T = \frac{q \times \Delta V_{BE}}{\eta \times k \times \ln\left(\frac{I_{C2}}{I_{C1}}\right)} \quad (5)$$

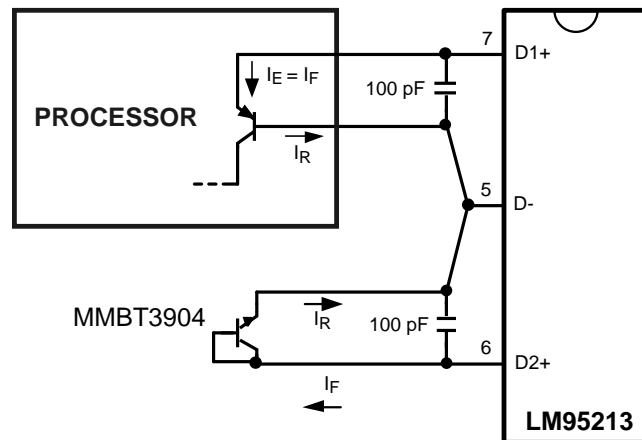

Figure 16. Thermal Diode Current Paths

TruTherm technology can be found in the LM95233 two channel remote diode sensor that is pin and register compatible with the LM95213. The LM95213 does not support this technology.

Calculating Total System Accuracy

The voltage seen by the LM95213 also includes the $I_F R_S$ voltage drop of the series resistance. The non-ideality factor, η , is the only other parameter not accounted for and depends on the diode that is used for measurement. Since ΔV_{BE} is proportional to both η and T , the variations in η cannot be distinguished from variations in temperature. Since the non-ideality factor is not controlled by the temperature sensor, it will directly add to the inaccuracy of the sensor. For the Intel processor on 65 nm process, Intel specifies a +4.06%/–0.897% variation in η from part to part when the processor diode is measured by a circuit that assumes diode equation, Equation 4, as true. As an example, assume a temperature sensor has an accuracy specification of $\pm 1.0^\circ\text{C}$ at a temperature of 80°C (353 Kelvin) and the processor diode has a non-ideality variation of +1.19%/–0.27%. The resulting system accuracy of the processor temperature being sensed will be:

$$T_{ACC} = + 1.0^\circ\text{C} + (+4.06\% \text{ of } 353 \text{ K}) = +15.3^\circ\text{C}$$

and

$$T_{ACC} = - 1.0^\circ\text{C} + (-0.89\% \text{ of } 353 \text{ K}) = -4.1^\circ\text{C}$$

The next error term to be discussed is that due to the series resistance of the thermal diode and printed circuit board traces. The thermal diode series resistance is specified on most processor data sheets. For Intel processors in 65 nm process, this is specified at 4.52Ω typical. The LM95213 accommodates the typical series resistance of Intel Processor on 65 nm process. The error that is not accounted for is the spread of the processor's series resistance, that is 2.79Ω to 6.24Ω or ±1.73Ω. The equation to calculate the temperature error due to series resistance (T_{ER}) for the LM95213 is simply:

$$T_{ER} = \left(0.62 \frac{^{\circ}\text{C}}{\Omega}\right) \times R_{PCB} \quad (6)$$

Solving [Equation 6](#) for R_{PCB} equal to ±1.73Ω results in the additional error due to the spread in the series resistance of ±1.07°C. The spread in error cannot be canceled out, as it would require measuring each individual thermal diode device. This is quite difficult and impractical in a large volume production environment.

[Equation 6](#) can also be used to calculate the additional error caused by series resistance on the printed circuit board. Since the variation of the PCB series resistance is minimal, the bulk of the error term is always positive and can simply be cancelled out by subtracting it from the output readings of the LM95213.

Processor Family	Diode Equation η_D , non-ideality			Series R_s ,Ω
	min	typ	max	
Pentium III CPUID 67h	1	1.0065	1.0125	
Pentium III CPUID 68h/PGA370Socket/ Celeron	1.0057	1.008	1.0125	
Pentium 4, 423 pin	0.9933	1.0045	1.0368	
Pentium 4, 478 pin	0.9933	1.0045	1.0368	
Pentium 4 on 0.13 micron process, 2 - 3.06 GHz	1.0011	1.0021	1.0030	3.64
Pentium 4 on 90 nm process	1.0083	1.011	1.023	3.33
Intel Processor on 65 nm process	1.000	1.009	1.050	4.52
Pentium M (Centrino)	1.00151	1.00220	1.00289	3.06
MMBT3904		1.003		
AMD Athlon MP model 6	1.002	1.008	1.016	
AMD Athlon 64	1.008	1.008	1.096	
AMD Opteron	1.008	1.008	1.096	
AMD Sempron		1.00261		0.93

Compensating for Different Non-Ideality

In order to compensate for the errors introduced by non-ideality, the temperature sensor is calibrated for a particular processor. National Semiconductor temperature sensors are always calibrated to the typical non-ideality and series resistance of a given processor type. The LM95213 is calibrated for non-ideality factor and series resistance values supporting the MMBT3904 transistor without the requirement for additional trims. When a temperature sensor calibrated for a particular processor type is used with a different processor type, additional errors are introduced.

Temperature errors associated with non-ideality of different processor types may be reduced in a specific temperature range of concern through use of software calibration. Typical Non-ideality specification differences cause a gain variation of the transfer function, therefore the center of the temperature range of interest should be the target temperature for calibration purposes. The following equation can be used to calculate the temperature correction factor (T_{CF}) required to compensate for a target non-ideality differing from that supported by the LM95213.

$$T_{CF} = \left(\frac{\eta_S - \eta_{\text{PROCESSOR}}}{\eta_S}\right) \times (T_{CR} + 273K)$$

where

- η_S = LM95213 non-ideality for accuracy specification
- $\eta_{\text{PROCESSOR}}$ = Processor thermal diode typical non-ideality

- T_{CR} = center of the temperature range of interest in °C (7)

The correction factor should be directly added to the temperature reading produced by the LM95213. For example when using the LM95213 to measure a AMD Athlon processor, with a typical non-ideality of 1.008, for a temperature range of 60 °C to 100 °C the correction factor would calculate to:

$$T_{CF} = \left(\frac{1.003 - 1.008}{1.003} \right) \cdot (80 + 273) = -1.75^{\circ}\text{C} \quad (8)$$

Therefore, 1.75°C should be subtracted from the temperature readings of the LM95213 to compensate for the differing typical non-ideality target.

PCB LAYOUT FOR MINIMIZING NOISE

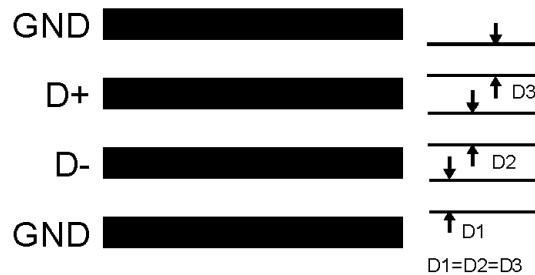

Figure 17. Ideal Diode Trace Layout

In a noisy environment, such as a processor mother board, layout considerations are very critical. Noise induced on traces running between the remote temperature diode sensor and the LM95213 can cause temperature conversion errors. Keep in mind that the signal level the LM95213 is trying to measure is in microvolts. The following guidelines should be followed:

1. V_{DD} should be bypassed with a 0.1 μF capacitor in parallel with 100 pF. The 100 pF capacitor should be placed as close as possible to the power supply pin. A bulk capacitance of approximately 10 μF needs to be in the near vicinity of the LM95213.
2. A 100 pF diode bypass capacitor is recommended to filter high frequency noise but may not be necessary. Make sure the traces to the 100 pF capacitor are matched. Place the filter capacitors close to the LM95213 pins.
3. Ideally, the LM95213 should be placed within 10 cm of the Processor diode pins with the traces being as straight, short and identical as possible. Trace resistance of 1 Ω can cause as much as 0.62°C of error. This error can be compensated by using simple software offset compensation.
4. Diode traces should be surrounded by a GND guard ring to either side, above and below if possible. This GND guard should not be between the D+ and D- lines. In the event that noise does couple to the diode lines it would be ideal if it is coupled common mode. That is equally to the D+ and D- lines.
5. Avoid routing diode traces in close proximity to power supply switching or filtering inductors.
6. Avoid running diode traces close to or parallel to high speed digital and bus lines. Diode traces should be kept at least 2 cm apart from the high speed digital traces.
7. If it is necessary to cross high speed digital traces, the diode traces and the high speed digital traces should cross at a 90 degree angle.
8. The ideal place to connect the LM95213's GND pin is as close as possible to the Processors GND associated with the sense diode.
9. Leakage current between D+ and GND and between D+ and D- should be kept to a minimum. Thirteen nano-amperes of leakage can cause as much as 0.2°C of error in the diode temperature reading. Keeping the printed circuit board as clean as possible will minimize leakage current.

Noise coupling into the digital lines greater than 400 mVp-p (typical hysteresis) and undershoot less than 500 mV below GND, may prevent successful SMBus communication with the LM95213. SMBus no acknowledge is the most common symptom, causing unnecessary traffic on the bus. Although the SMBus maximum frequency of communication is rather low (100 kHz max), care still needs to be taken to ensure proper termination within a system with multiple parts on the bus and long printed circuit board traces. An RC lowpass filter with a 3 dB corner frequency of about 40 MHz is included on the LM95213's SMBCLK input. Additional resistance can be added in series with the SMBDAT and SMBCLK lines to further help filter noise and ringing. Minimize noise coupling by keeping digital traces out of switching power supply areas as well as ensuring that digital lines containing high speed data communications cross at right angles to the SMBDAT and SMBCLK lines.

REVISION HISTORY

Changes from Original (March 2013) to Revision A	Page
• Changed layout of National Data Sheet to TI format	37

PACKAGING INFORMATION

Orderable Device	Status (1)	Package Type	Package Drawing	Pins	Package Qty	Eco Plan (2)	Lead/Ball Finish (6)	MSL Peak Temp (3)	Op Temp (°C)	Device Marking (4/5)	Samples
LM95213CISD/NOPB	ACTIVE	WSON	NHL	14	1000	Green (RoHS & no Sb/Br)	CU SN	Level-1-260C-UNLIM	-40 to 140	95213CI	Samples

(1) The marketing status values are defined as follows:

ACTIVE: Product device recommended for new designs.

LIFEBUY: TI has announced that the device will be discontinued, and a lifetime-buy period is in effect.

NRND: Not recommended for new designs. Device is in production to support existing customers, but TI does not recommend using this part in a new design.

PREVIEW: Device has been announced but is not in production. Samples may or may not be available.

OBSOLETE: TI has discontinued the production of the device.

(2) **RoHS:** TI defines "RoHS" to mean semiconductor products that are compliant with the current EU RoHS requirements for all 10 RoHS substances, including the requirement that RoHS substance do not exceed 0.1% by weight in homogeneous materials. Where designed to be soldered at high temperatures, "RoHS" products are suitable for use in specified lead-free processes. TI may reference these types of products as "Pb-Free".

RoHS Exempt: TI defines "RoHS Exempt" to mean products that contain lead but are compliant with EU RoHS pursuant to a specific EU RoHS exemption.

Green: TI defines "Green" to mean the content of Chlorine (Cl) and Bromine (Br) based flame retardants meet JS709B low halogen requirements of <=1000ppm threshold. Antimony trioxide based flame retardants must also meet the <=1000ppm threshold requirement.

(3) MSL, Peak Temp. - The Moisture Sensitivity Level rating according to the JEDEC industry standard classifications, and peak solder temperature.

(4) There may be additional marking, which relates to the logo, the lot trace code information, or the environmental category on the device.

(5) Multiple Device Markings will be inside parentheses. Only one Device Marking contained in parentheses and separated by a "~" will appear on a device. If a line is indented then it is a continuation of the previous line and the two combined represent the entire Device Marking for that device.

(6) Lead/Ball Finish - Orderable Devices may have multiple material finish options. Finish options are separated by a vertical ruled line. Lead/Ball Finish values may wrap to two lines if the finish value exceeds the maximum column width.

Important Information and Disclaimer:The information provided on this page represents TI's knowledge and belief as of the date that it is provided. TI bases its knowledge and belief on information provided by third parties, and makes no representation or warranty as to the accuracy of such information. Efforts are underway to better integrate information from third parties. TI has taken and continues to take reasonable steps to provide representative and accurate information but may not have conducted destructive testing or chemical analysis on incoming materials and chemicals. TI and TI suppliers consider certain information to be proprietary, and thus CAS numbers and other limited information may not be available for release.

In no event shall TI's liability arising out of such information exceed the total purchase price of the TI part(s) at issue in this document sold by TI to Customer on an annual basis.

TAPE AND REEL INFORMATION



QUADRANT ASSIGNMENTS FOR PIN 1 ORIENTATION IN TAPE



*All dimensions are nominal

Device	Package Type	Package Drawing	Pins	SPQ	Reel Diameter (mm)	Reel Width W1 (mm)	A0 (mm)	B0 (mm)	K0 (mm)	P1 (mm)	W (mm)	Pin1 Quadrant
LM95213CISD/NOPB	WSON	NHL	14	1000	178.0	12.4	4.3	4.3	1.3	8.0	12.0	Q1

TAPE AND REEL BOX DIMENSIONS



*All dimensions are nominal

Device	Package Type	Package Drawing	Pins	SPQ	Length (mm)	Width (mm)	Height (mm)
LM95213CISD/NOPB	WSON	NHL	14	1000	210.0	185.0	35.0

NHL0014B

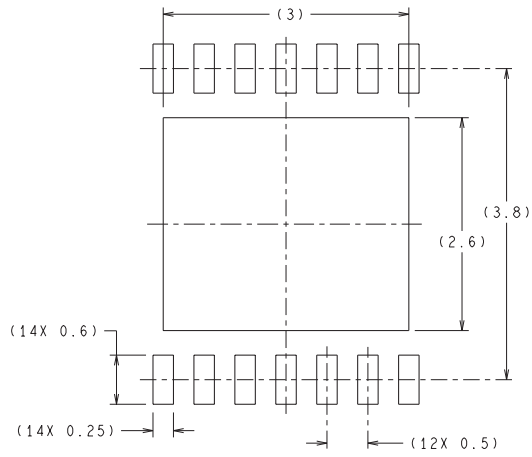

RECOMMENDED LAND PATTERN

DIMENSIONS ARE IN MILLIMETERS
DIMENSIONS IN () FOR REFERENCE ONLY

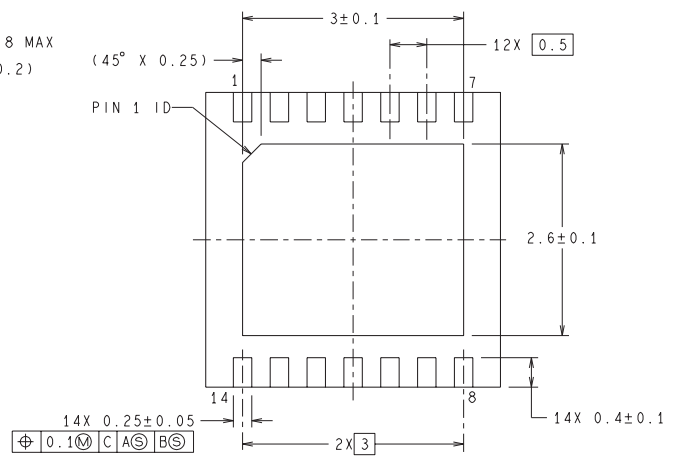
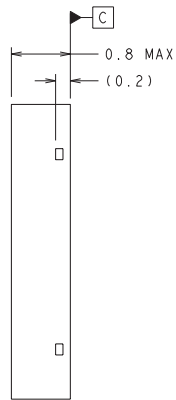
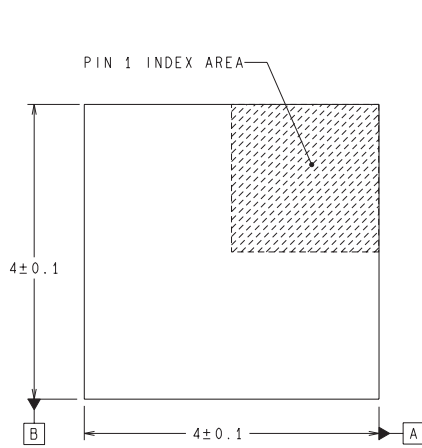

SDA14B (Rev A)

IMPORTANT NOTICE AND DISCLAIMER

TI PROVIDES TECHNICAL AND RELIABILITY DATA (INCLUDING DATASHEETS), DESIGN RESOURCES (INCLUDING REFERENCE DESIGNS), APPLICATION OR OTHER DESIGN ADVICE, WEB TOOLS, SAFETY INFORMATION, AND OTHER RESOURCES "AS IS" AND WITH ALL FAULTS, AND DISCLAIMS ALL WARRANTIES, EXPRESS AND IMPLIED, INCLUDING WITHOUT LIMITATION ANY IMPLIED WARRANTIES OF MERCHANTABILITY, FITNESS FOR A PARTICULAR PURPOSE OR NON-INFRINGEMENT OF THIRD PARTY INTELLECTUAL PROPERTY RIGHTS.

These resources are intended for skilled developers designing with TI products. You are solely responsible for (1) selecting the appropriate TI products for your application, (2) designing, validating and testing your application, and (3) ensuring your application meets applicable standards, and any other safety, security, or other requirements. These resources are subject to change without notice. TI grants you permission to use these resources only for development of an application that uses the TI products described in the resource. Other reproduction and display of these resources is prohibited. No license is granted to any other TI intellectual property right or to any third party intellectual property right. TI disclaims responsibility for, and you will fully indemnify TI and its representatives against, any claims, damages, costs, losses, and liabilities arising out of your use of these resources.

TI's products are provided subject to TI's Terms of Sale (www.ti.com/legal/termsofsale.html) or other applicable terms available either on ti.com or provided in conjunction with such TI products. TI's provision of these resources does not expand or otherwise alter TI's applicable warranties or warranty disclaimers for TI products.

Mailing Address: Texas Instruments, Post Office Box 655303, Dallas, Texas 75265
Copyright © 2018, Texas Instruments Incorporated

Looking for pricing, stock, or lifecycle information?

Click below to explore more details on WIN SOURCE:

 [View LM95213CISD/NOPB on WIN SOURCE](#)

 [Texas Instruments](#) Information

Optimize Your Supply Chain with WIN SOURCE Solutions

-  Global Sourcing Solution
-  Obsolete Management
-  Cost Control Management
-  Shortage Management
-  Alternative Solution
-  Excess Inventory Management