

LMC603x CMOS Dual Operational Amplifiers

1 Features

- Specified for 2kΩ and 600Ω loads
- High voltage gain: 126dB, 2kΩ
- Low offset voltage drift: 2.3μV/°C
- Ultra-low input bias current: 40fA
- Input common-mode range includes V-
- Operates on standard 5V and 15V supplies
- $I_Q = 375\mu\text{A}/\text{amplifier}$; independent of V+
- Low noise: 22nV/√Hz
- Slew rate: 1.1V/μs
- Improved performance over TLC272

2 Applications

- High-impedance buffer or preamplifier
- Current-to-voltage converter
- Long-term integrator
- Sample-and-hold circuit
- Medical instrumentation

3 Description

The dual LMC6032 and quad LMC6034 (LMC603x) are CMOS operational amplifiers that operate from either a single supply or dual supplies. Device performance features include an input common-mode range that reaches ground, low input bias current, and high voltage gain into realistic loads, such as 2kΩ and 600Ω.

This chip is built with TI's advanced CMOS process.

For higher-performance characteristics, see the [OPA928](#).

Device Information

PART NUMBER	CHANNEL	PACKAGE ⁽¹⁾
LMC6032	Dual	D (SOIC, 8)
		P (PDIP, 8)
LMC6034	Quad	D (SOIC, 14)
		P (PDIP, 14)

(1) For more information, see [Section 9](#).

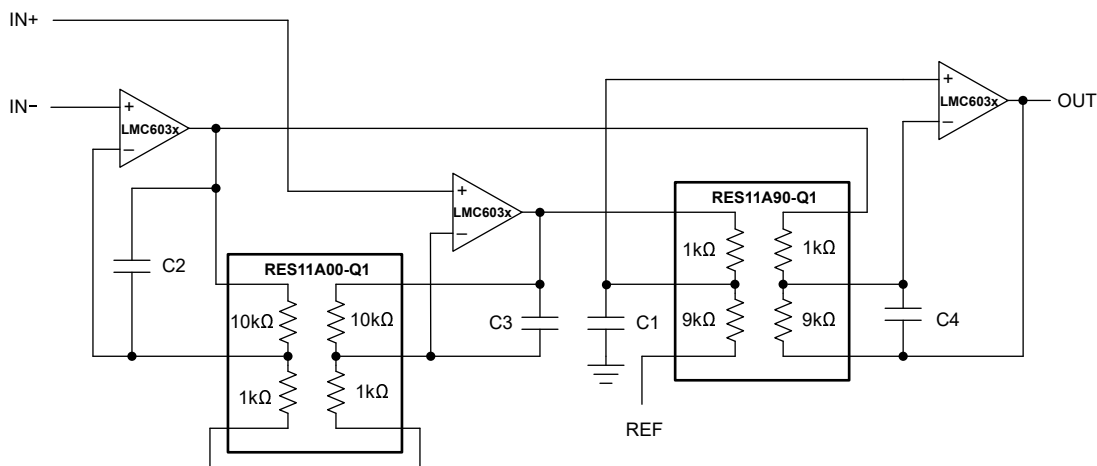

Typical Application: Instrumentation Amplifier With RES11A

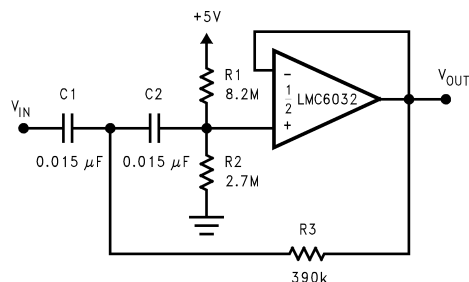

Typical Application: 10Hz High-Pass Filter



Table of Contents

1 Features	1	6 Application and Implementation	11
2 Applications	1	6.1 Application Information.....	11
3 Description	1	6.2 Typical Applications.....	15
4 Pin Configuration and Functions	2	6.3 Layout.....	18
5 Specifications	4	7 Device and Documentation Support	20
5.1 Absolute Maximum Ratings.....	4	7.1 Receiving Notification of Documentation Updates....	20
5.2 ESD Ratings.....	4	7.2 Support Resources.....	20
5.3 Recommended Operating Conditions.....	4	7.3 Electrostatic Discharge Caution.....	20
5.4 Thermal Information LMC6032.....	5	7.4 Glossary.....	20
5.5 Thermal Information LMC6034.....	5	8 Revision History	20
5.6 Electrical Characteristics.....	6	9 Mechanical, Packaging, and Orderable Information ..	21
Typical Characteristics.....	8		

4 Pin Configuration and Functions

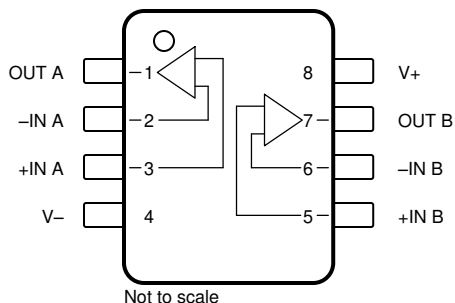

LMC6032 D Package, 8-Pin SOIC, and P Package, 8-Pin PDIP (Top View)

Table 4-1. Pin Functions: LMC6032

PIN		TYPE	DESCRIPTION
NAME	NO.		
+IN A	3	Input	Noninverting input, channel A
-IN A	2	Input	Inverting input, channel A
+IN B	5	Input	Noninverting input, channel B
-IN B	6	Input	Inverting input, channel B
OUT A	1	Output	Output, channel A
OUT B	7	Output	Output, channel B
V+	8	Power	Positive (highest) power supply
V-	4	Power	Negative (lowest) power supply

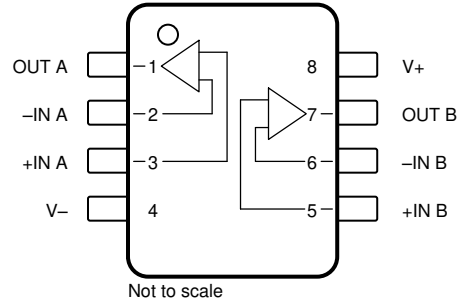

LMC6034 D Package, 14-Pin SOIC, and P Package, 14-Pin PDIP (Top View)

Table 4-2. Pin Functions: LMC6034

PIN		TYPE	DESCRIPTION
NAME	NO.		
+IN A	3	Input	Noninverting input, channel A
+IN B	5	Input	Noninverting input, channel B
+IN C	10	Input	Noninverting input, channel C
+IN D	12	Input	Noninverting input, channel D
-IN A	2	Input	Inverting input, channel A
-IN B	6	Input	Inverting input, channel B
-IN C	9	Input	Inverting input, channel C
-IN D	13	Input	Inverting input, channel D
OUT A	1	Output	Output, channel A
OUT B	7	Output	Output, channel B
OUT C	8	Output	Output, channel C
OUT D	14	Output	Output, channel D
V+	4	Power	Positive (highest) power supply
V-	11	Power	Negative (lowest) power supply

5 Specifications

5.1 Absolute Maximum Ratings

over operating free-air temperature range (unless otherwise noted)^{(1) (2)}

		MIN	MAX	UNIT
Differential input voltage			±Supply voltage	V
Supply voltage, $V_S = (V+) - (V-)$	Single supply	0	16	V
	Dual supply		±8	
Output short circuit	To V+		See ⁽²⁾	mA
	To V-		See ⁽³⁾	
Signal input pins	Voltage	(V-) – 0.3	(V+) + 0.3	V
	Current		±5	mA
Output pin current			±18	mA
Power supply pin	Current		35	mA
Power dissipation		See ⁽⁴⁾		
Temperature	Operating, T_A	–40	150	°C
	Junction, T_J		150	
	Storage, T_{stg}	–65	150	
	Lead (soldering, 10 sec.)		260	

- (1) Stresses beyond those listed under *Absolute Maximum Ratings* may cause permanent damage to the device. These are stress ratings only, which do not imply functional operation of the device at these or any other conditions beyond those indicated under *Recommended Operating Conditions*. Exposure to absolute-maximum-rated conditions for extended periods may affect device reliability.
- (2) If Military/Aerospace specified devices are required, please contact the TI Sales Office/Distributors for availability and specifications.
- (3) Do not connect output to V+, when V+ is greater than 13V or reliability will be adversely affected.
- (4) The maximum power dissipation is a function of $T_{J(max)}$, θ_{JA} , and T_A . The maximum allowable power dissipation at any ambient temperature is $P_D = (T_{J(max)} - T_A) / \theta_{JA}$

5.2 ESD Ratings

			VALUE	UNIT
$V_{(ESD)}$	Electrostatic discharge	Human-body model (HBM), per ANSI/ESDA/JEDEC JS-001 ⁽¹⁾	±1000	V

- (1) JEDEC document JEP155 states that 500V HBM allows safe manufacturing with a standard ESD control process.

5.3 Recommended Operating Conditions

over operating free-air temperature range (unless otherwise noted)⁽¹⁾

		MIN	NOM	MAX	UNIT
Supply voltage, $V_S = (V+) - (V-)$	Single supply	4.75		15.5	V
	Dual supply	±2.375		±7.75	
Specified temperature		–40		85	°C
Power dissipation				See ⁽²⁾	

- (1) Absolute Maximum Ratings indicate limits beyond which damage to the device may occur. Operating Ratings indicate conditions for which the device is intended to be functional, but do not ensure specific performance limits. For ensured specifications and test conditions, see the *Electrical Characteristics*. The ensured specifications apply only for the test conditions listed.
- (2) For operating at elevated temperatures the device must be derated based on the thermal resistance θ_{JA} with $P_D = (T_J - T_A) / \theta_{JA}$. All numbers apply for packages soldered directly into a printed circuit board.

5.4 Thermal Information LMC6032

THERMAL METRIC ⁽¹⁾		LMC6032		UNIT
		D (SOIC)	P (PDIP)	
		8 PINS	8 PINS	
R _{θJA}	Junction-to-ambient thermal resistance	165	101	°C/W

(1) For more information about traditional and new thermal metrics, see the [Semiconductor and IC Package Thermal Metrics](#) application report.

5.5 Thermal Information LMC6034

THERMAL METRIC ⁽¹⁾		LMC6034		UNIT
		D (SOIC)	P (PDIP)	
		14 PINS	14 PINS	
R _{θJA}	Junction-to-ambient thermal resistance	115	85	°C/W

(1) For more information about traditional and new thermal metrics, see the [Semiconductor and IC Package Thermal Metrics](#) application report.

5.6 Electrical Characteristics

at $T_A = +25^\circ\text{C}$, $V_S = 5\text{V}$ ($V_- = 0\text{V}$), $V_{CM} = 1.5\text{V}$, $V_{OUT} = V_S / 2$, and $R_L = 1\text{M}\Omega$ connected to $V_S / 2$ (unless otherwise noted)

PARAMETER		TEST CONDITIONS		MIN	TYP	MAX	UNIT	
OFFSET VOLTAGE								
V_{OS}	Input offset voltage				± 1	± 9	mV	
		$T_A = -40^\circ\text{C}$ to $+85^\circ\text{C}$				± 11		
dV_{OS}/dT	Input offset voltage drift	$T_A = -40^\circ\text{C}$ to $+85^\circ\text{C}$			± 2.3		$\mu\text{V}/^\circ\text{C}$	
PSRR	Power-supply rejection ratio	Positive, $5\text{V} \leq V_+ \leq 15\text{V}$			63	83	dB	
			$T_A = -40^\circ\text{C}$ to $+85^\circ\text{C}$		60			
		Negative, $-5\text{V} \leq V_+ \leq -10\text{V}$			74	94		
			$T_A = -40^\circ\text{C}$ to $+85^\circ\text{C}$		70			
INPUT BIAS CURRENT								
I_B	Input bias current				± 40		fA	
		$T_A = -40^\circ\text{C}$ to $+85^\circ\text{C}$				± 200	pA	
I_{OS}	Input offset current				± 10		fA	
		$T_A = -40^\circ\text{C}$ to $+85^\circ\text{C}$				± 100	pA	
NOISE								
e_n	Input voltage noise density	$f = 1\text{kHz}$			22		$\text{nV}/\sqrt{\text{Hz}}$	
i_n	Input current noise density	$f = 1\text{kHz}$			4		$\text{fA}/\sqrt{\text{Hz}}$	
THD	Total harmonic distortion	$f = 10\text{kHz}$, $G = -10\text{V/V}$, $R_L = 2\text{k}\Omega$, $V_O = 8V_{pp}$, $V_S = \pm 5\text{V}$			0.2		%	
INPUT VOLTAGE								
V_{CM}	Common-mode voltage range	To positive rail, $5\text{V} \leq V_S \leq 15\text{V}$, $\text{CMRR} > 50\text{dB}$			$(V_+) - 2.3$	$(V_+) - 1.9$	V	
			$T_A = -40^\circ\text{C}$ to $+85^\circ\text{C}$		$(V_+) - 2.6$			
		To negative rail, $5\text{V} \leq V_S \leq 15\text{V}$, $\text{CMRR} > 50\text{dB}$				$(V_-) - 0.4$		$(V_-) - 0.1$
			$T_A = -40^\circ\text{C}$ to $+85^\circ\text{C}$			(V_-)		
CMRR	Common-mode rejection ratio	$V_S = 15\text{V}$, $0\text{V} < V_{CM} < 12\text{V}$			63	83	dB	
			$T_A = -40^\circ\text{C}$ to $+85^\circ\text{C}$		60			
INPUT IMPEDANCE								
R_{IN}	Input resistance				> 1		$\text{T}\Omega$	
OPEN-LOOP GAIN								
A_{OL}	Open-loop voltage gain	Sourcing, $V_S = 15\text{V}$, $V_{CM} = 7.5\text{V}$, $7.5\text{V} < V_O < 11.5\text{V}$, $R_L = 2\text{k}\Omega$			200	2000	V/mV	
			$T_A = -40^\circ\text{C}$ to $+85^\circ\text{C}$		100			
		Sinking, $V_S = 15\text{V}$, $V_{CM} = 7.5\text{V}$, $2.5\text{V} < V_O < 7.5\text{V}$, $R_L = 2\text{k}\Omega$			90	500		
			$T_A = -40^\circ\text{C}$ to $+85^\circ\text{C}$		40			
		Sourcing, $V_S = 15\text{V}$, $V_{CM} = 7.5\text{V}$, $7.5\text{V} < V_O < 11.5\text{V}$, $R_L = 600\Omega$			100	1000		
			$T_A = -40^\circ\text{C}$ to $+85^\circ\text{C}$		75			
		Sinking, $V_S = 15\text{V}$, $V_{CM} = 7.5\text{V}$, $2.5\text{V} < V_O < 7.5\text{V}$, $R_L = 600\Omega$			50	250		
			$T_A = -40^\circ\text{C}$ to $+85^\circ\text{C}$		20			
FREQUENCY RESPONSE								
GBW	Gain bandwidth product				1.4		MHz	
SR	Slew rate ⁽¹⁾	$V_S = 15\text{V}$, 10V step			0.8	1.1	$\text{V}/\mu\text{s}$	
			$T_A = -40^\circ\text{C}$ to $+85^\circ\text{C}$		0.4			
θ_m	Phase margin				50		$^\circ$	
	Crosstalk	Dual and quad channel, $V_S = 15\text{V}$, $R_L = 10\text{k}\Omega$ to 7.5V , $f = 1\text{kHz}$, $V_O = 13V_{pp}$			130		dB	

5.6 Electrical Characteristics (continued)

at $T_A = +25^\circ\text{C}$, $V_S = 5\text{V}$ ($V_- = 0\text{V}$), $V_{CM} = 1.5\text{V}$, $V_{OUT} = V_S / 2$, and $R_L = 1\text{M}\Omega$ connected to $V_S / 2$ (unless otherwise noted)

PARAMETER		TEST CONDITIONS		MIN	TYP	MAX	UNIT
OUTPUT							
V_O	Voltage output swing	Positive rail $V_S = 5\text{V}$, $R_L = 2\text{k}\Omega$ to mid-supply	$T_A = -40^\circ\text{C}$ to $+85^\circ\text{C}$	4.20	4.87		V
				4.00			
		Negative rail $V_S = 5\text{V}$, $R_L = 2\text{k}\Omega$ to mid-supply	$T_A = -40^\circ\text{C}$ to $+85^\circ\text{C}$		0.10	0.25	
					0.35		
		Positive rail $V_S = 5\text{V}$, $R_L = 600\Omega$ to mid-supply	$T_A = -40^\circ\text{C}$ to $+85^\circ\text{C}$	4.00	4.61		
				3.80			
		Negative rail $V_S = 5\text{V}$, $R_L = 600\Omega$ to mid-supply	$T_A = -40^\circ\text{C}$ to $+85^\circ\text{C}$		0.30	0.63	
					0.75		
I_{SC}	Short-circuit current	Sourcing $V_S = 5\text{V}$, $V_O = 0\text{V}$	$T_A = -40^\circ\text{C}$ to $+85^\circ\text{C}$	13	22		mA
				9			
		Sinking $V_S = 5\text{V}$, $V_O = 5\text{V}$	$T_A = -40^\circ\text{C}$ to $+85^\circ\text{C}$	13	21		
				9			
Sourcing $V_S = 15\text{V}$, $V_O = 0\text{V}$	$T_A = -40^\circ\text{C}$ to $+85^\circ\text{C}$	23	40				
		15					
Sinking $V_S = 15\text{V}$, $V_O = 13\text{V}^{(2)}$	$T_A = -40^\circ\text{C}$ to $+85^\circ\text{C}$	23	39				
		15					
POWER SUPPLY							
I_Q	Quiescent current per amplifier	$V_O = 1.5\text{V}$	LMC6032		375	800	μA
			LMC6032, $T_A = -40^\circ\text{C}$ to $+85^\circ\text{C}$			950	
			LMC6034		375	675	
			LMC6034, $T_A = -40^\circ\text{C}$ to $+85^\circ\text{C}$			750	

- (1) Specification limit established from device population bench system measurements across multiple lots. Number specified is the slower of either the positive or negative slew rates.
- (2) Do not connect output to V_+ , when V_+ is greater than 13V or reliability can be adversely affected.

Typical Characteristics

at $T_A = 25^\circ\text{C}$, $V_S = \pm 7.5\text{V}$, $V_{OUT} = \text{mid-supply}$, and $R_L > 1\text{M}\Omega$ (unless otherwise noted)

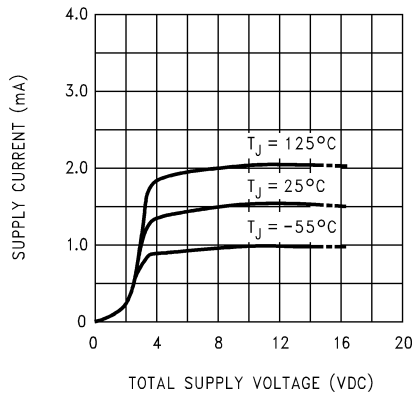

Figure 5-1. Supply Current vs Supply Voltage

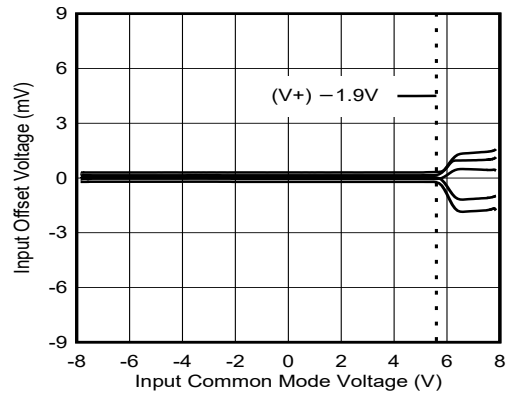

Figure 5-2. Offset Voltage vs Input Common-Mode Voltage

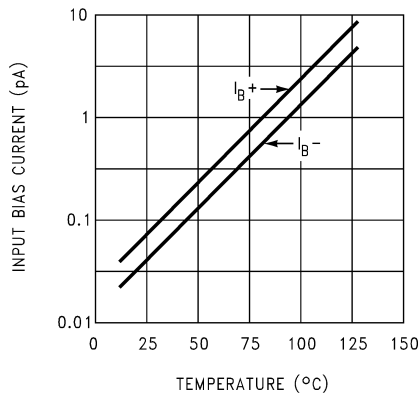

Figure 5-3. Input Bias Current

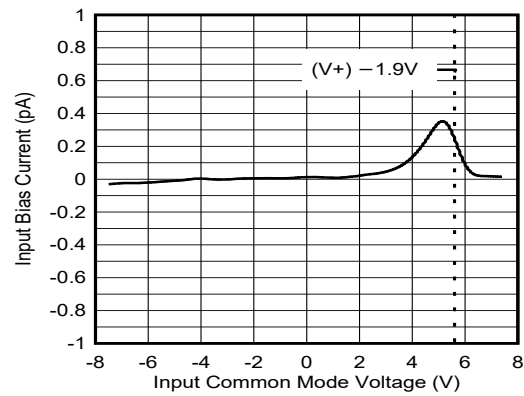

Figure 5-4. Input Bias Current vs Input Common-Mode Voltage

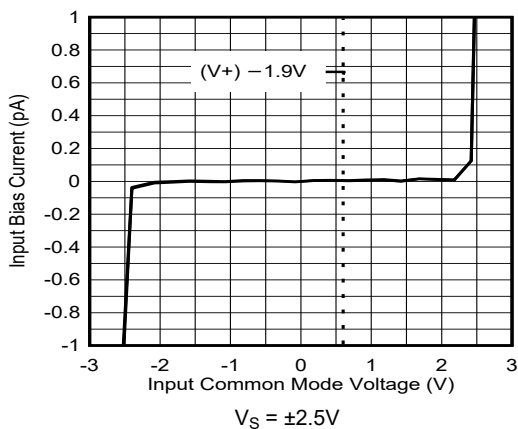

Figure 5-5. Input Bias Current vs Input Common-Mode Voltage

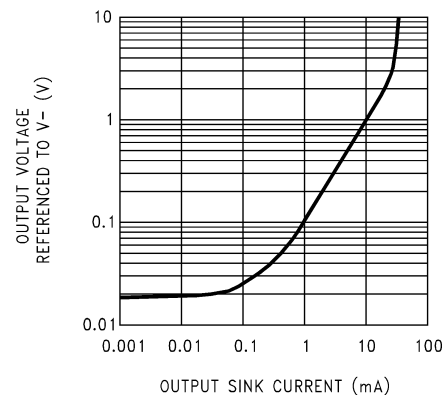

Figure 5-6. Output Characteristics Current Sinking

Typical Characteristics (continued)

at $T_A = 25^\circ\text{C}$, $V_S = \pm 7.5\text{V}$, $V_{OUT} = \text{mid-supply}$, and $R_L > 1\text{M}\Omega$ (unless otherwise noted)

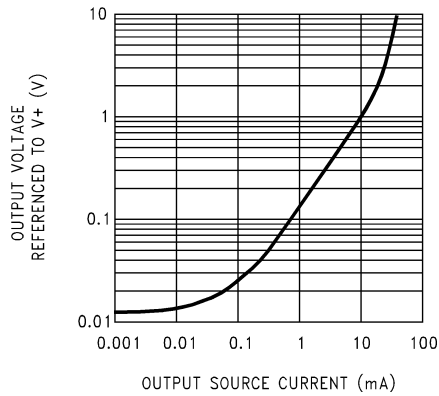

Figure 5-7. Output Characteristics Current Sourcing

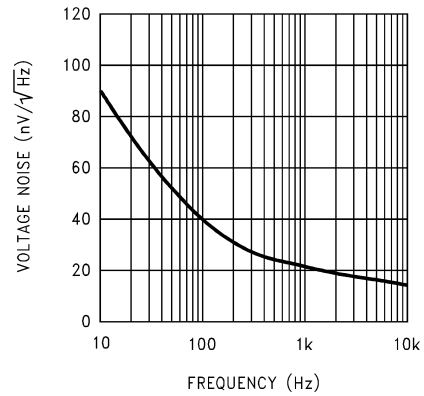

Figure 5-8. Input Voltage Noise vs Frequency

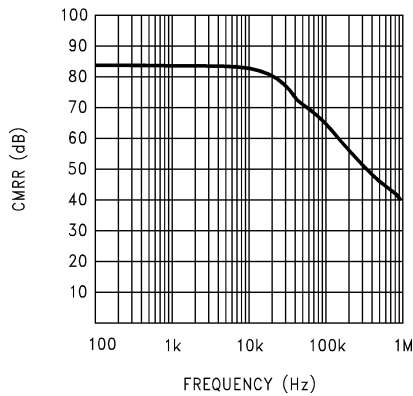

Figure 5-9. CMRR vs Frequency

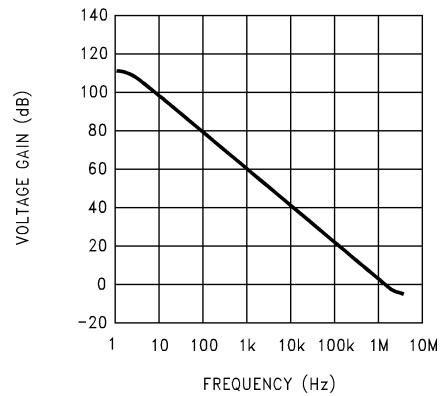

Figure 5-10. Open-Loop Frequency Response

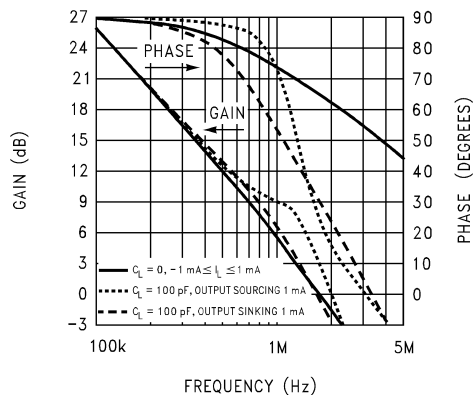

Figure 5-11. Frequency Response vs Capacitive Load

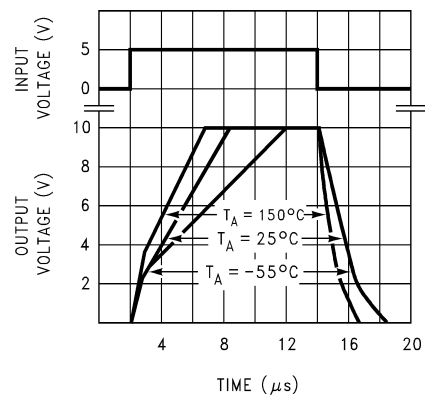

Figure 5-12. Noninverting Large-Signal Pulse Response

Typical Characteristics (continued)

at $T_A = 25^\circ\text{C}$, $V_S = \pm 7.5\text{V}$, $V_{OUT} = \text{mid-supply}$, and $R_L > 1\text{M}\Omega$ (unless otherwise noted)

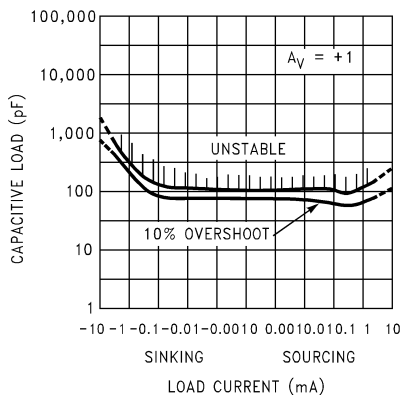

Figure 5-13. Stability vs Capacitive Load

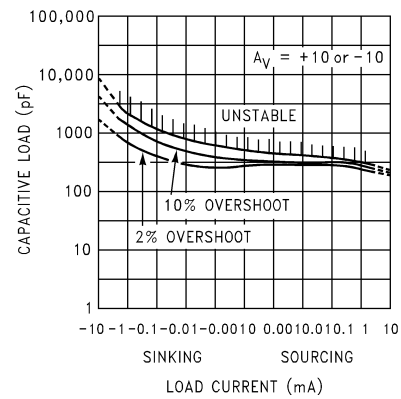

Figure 5-14. Stability vs Capacitive Load

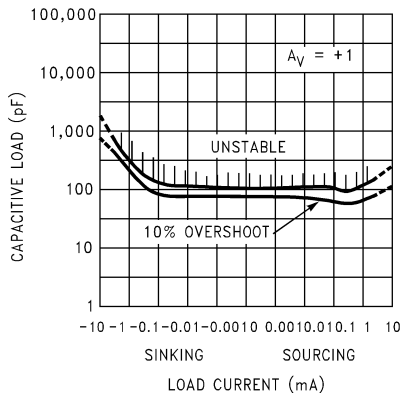
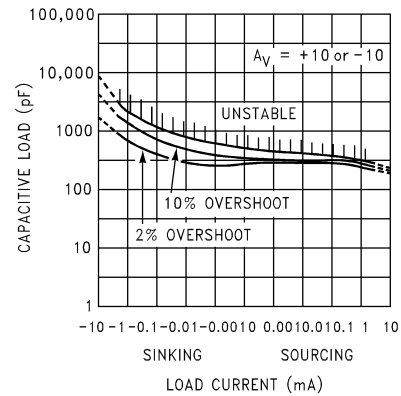

Figure 5-15. Stability vs Capacitive Load



Avoid resistive loads of less than 500Ω because these loads can cause instability.

Figure 5-16. Stability vs Capacitive Load

6 Application and Implementation

Note

Information in the following applications sections is not part of the TI component specification, and TI does not warrant its accuracy or completeness. TI's customers are responsible for determining suitability of components for their purposes, as well as validating and testing their design implementation to confirm system functionality.

6.1 Application Information

6.1.1 Amplifier Topology

The topology chosen for the LMC603x, shown in [Figure 6-1](#), is unconventional compared to general-purpose op amps. The LMC603x incorporates novel op-amp design that enables a wide input common-mode range and rail to rail output swing even when driving a large load. The input common-mode range includes ground, making the LMC603x an excellent choice for single-supply applications. While the LMC603x supports both a wide supply and common-mode voltage range, large input common-mode voltage can cause a degradation of input bias current performance.

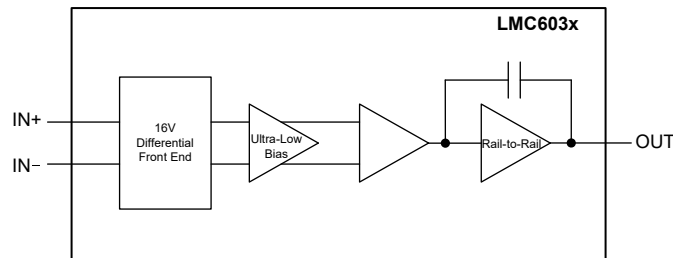

Figure 6-1. LMC603x Circuit Topology (Each Amplifier)

The large signal voltage gain while sourcing is comparable to traditional bipolar op amps, even with a 600Ω load. The gain while sinking is greater than most CMOS op amps as a result of the additional gain stage; however, under heavy load (600Ω), the gain can be reduced as indicated in [Section 5.6](#).

6.1.2 Compensating Input Capacitance

The high input resistance of the LMC603x op amps allows the use of large feedback and source resistor values without losing gain accuracy due to loading. However, the circuit can be especially sensitive to the printed circuit board (PCB) layout when these large-value resistors are used.

Every amplifier has some capacitance between each input and ac ground, and also some differential capacitance between the inputs. When the feedback network around an amplifier is resistive, this input capacitance (along with any additional capacitance due to circuit board traces, the socket, and so on) and the feedback resistors create a pole in the feedback path. In [Figure 6-2](#), the frequency of this pole is:

$$f_p = \frac{1}{2\pi C_S R_P} \quad (1)$$

where C_S is the total capacitance at the inverting input, including amplifier input capacitance and any stray capacitance from the IC socket (if one is used), circuit board traces, and so on, and R_P is the parallel combination of R_F and R_{IN} . This formula, as well as all the following formulas, apply to inverting and noninverting op-amp configurations.

When the feedback resistors are smaller than a few kΩ, the frequency of the feedback pole can be quite high, since C_S is generally less than 10pF. If the frequency of the feedback pole is much greater than the *ideal* closed-loop bandwidth (the nominal closed-loop bandwidth in the absence of C_S), the pole has a negligible effect on stability, as only a small amount of phase shift is added.

However, if the feedback pole is less than approximately 6 to 10 times the *ideal* –3dB frequency, add a feedback capacitor, C_F , between the output and the inverting input of the op amp. This condition can also be stated in terms of the amplifier low-frequency noise gain: To maintain stability, a feedback capacitor is probably needed if:

$$\left(\frac{R_F}{R_{IN}} + 1\right) \leq \sqrt{6 \times 2\pi \times GBW \times R_F \times C_S} \quad (2)$$

where

- $\left(\frac{R_F}{R_{IN}} + 1\right)$ is the amplifier low-frequency noise gain.
- GBW is the amplifier gain bandwidth product.

An amplifier low-frequency noise gain is represented by the following formula:

$$\left(\frac{R_F}{R_{IN}} + 1\right) \quad (3)$$

regardless of whether the amplifier is being used in an inverting or noninverting mode. A feedback capacitor is more likely to be needed when the noise gain is low, the feedback resistor is large, or both.

If the previous condition is met (indicating a feedback capacitor is probably be needed), and the noise gain is large enough that $\left(\frac{R_F}{R_{IN}} + 1\right) \geq 2\sqrt{GBW \times R_F \times C_S}$, the following value of feedback capacitor is recommended:

$$C_F = \frac{C_S}{2\left(\frac{R_F}{R_{IN}} + 1\right)} \quad (4)$$

If $\left(\frac{R_F}{R_{IN}} + 1\right) < 2\sqrt{GBW \times R_F \times C_S}$, the feedback capacitor is:

$$C_F = \sqrt{\frac{C_S}{GBW \times R_F}} \quad (5)$$

These capacitor values are usually significantly smaller than those given by the older, more conservative formula:

$$C_F = \frac{C_S R_{IN}}{R_F} \quad (6)$$

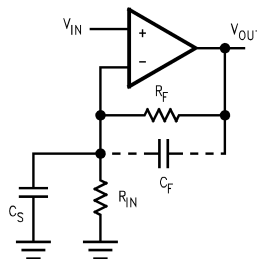

C_S consists of the amplifier input capacitance plus any stray capacitance from the circuit board and socket. C_F compensates for the pole caused by C_S and the feedback resistor.

Figure 6-2. General Operational Amplifier Circuit

Using the smaller capacitors give much higher bandwidth with little degradation of transient response. Using a somewhat larger feedback capacitor can be necessary in any of the above cases to allow for unexpected stray capacitance, or to tolerate additional phase shifts in the loop, or excessive capacitive load, or to decrease the noise or bandwidth, or simply because the particular circuit implementation needs more feedback capacitance

to be sufficiently stable. For example, a PCB stray capacitance can be larger or smaller than the breadboard capacitance, so the actual preferred value for C_F can be different from the one estimated using the breadboard. In most cases, check the value of C_F on the actual circuit, starting with the computed value.

6.1.3 Capacitive Load Tolerance

Like many other op amps, the LMC603x can oscillate when applied a load that appears capacitive. The threshold of oscillation varies both with load and circuit gain. The configuration most sensitive to oscillation is a unity-gain follower. See also [Section Typical Characteristics](#).

The load capacitance interacts with the op amp output resistance to create an additional pole. If this pole frequency is sufficiently low, the op amp phase margin is degraded so that the amplifier is no longer stable at low gains. [Figure 6-3](#) shows that the addition of a small resistor (50Ω to 100Ω) in series with the op amp output, and a capacitor (5pF to 10pF) from inverting input to output pins, returns the phase margin to a safe value without interfering with lower-frequency circuit operation. Thus, larger values of capacitance can be tolerated without oscillation. In all cases, the output can ring heavily when the load capacitance is near the threshold for oscillation.

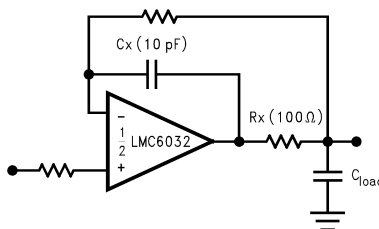

Figure 6-3. Rx, Cx Improve Capacitive Load Tolerance

Capacitive load driving capability is enhanced by using a pullup resistor to V^+ ([Figure 6-4](#)). Typically, a pullup resistor conducting $500\mu\text{A}$ or more significantly improves capacitive load responses. The value of the pullup resistor must be determined based on the current sinking capability of the amplifier with respect to the desired output swing. The open-loop gain of the amplifier can also be affected by the pullup resistor (see [Section 5.6](#)).

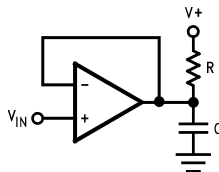

Figure 6-4. Compensating for Large Capacitive Loads with a Pullup Resistor

6.1.4 Bias Current Testing

The test method of [Figure 6-5](#) is appropriate for bench-testing bias current with reasonable accuracy. To understand the circuit operation, first close switch S2 momentarily. When S2 is opened, then:

$$I_{b-} = \frac{dV_{OUT}}{dt} \times C_2 \quad (7)$$

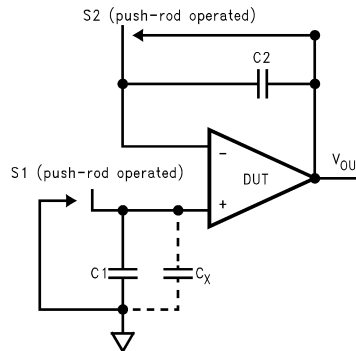

Figure 6-5. Simple Input Bias Current Test Circuit

A recommended capacitor for C2 is a 5pF or 10pF silver mica, NPO ceramic, or air-dielectric. When determining the magnitude of I_{b-} , the leakage of the capacitor and socket must be taken into account. Leave switch S2 shorted most of the time, or else the dielectric absorption of the capacitor C2 can cause errors.

Similarly, if S1 is shorted momentarily (while leaving S2 shorted), then:

$$I_{b+} = \frac{dV_{OUT}}{dt} \times (C_1 + C_x) \quad (8)$$

where C_x is the stray capacitance at the + input.

6.2 Typical Applications

Typical Single-Supply Applications

Additional single-supply applications ideas are found in the [LM358](#) data sheet. The LMC603x is pin-for-pin compatible with the LM358 and offers greater bandwidth and input resistance over the LM358. These features can improve the performance of many existing single-supply applications. Be aware, however, the supply voltage range of the LMC603x is smaller than that of the LM358.

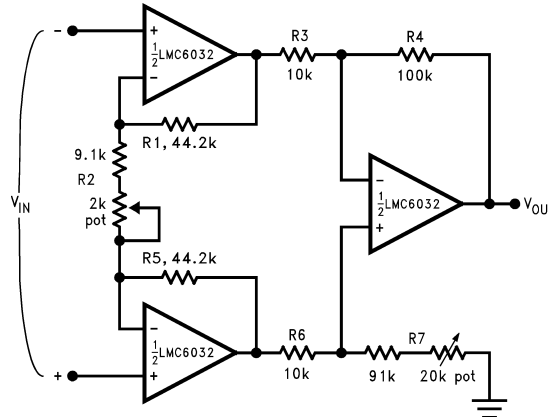

Figure 6-6. Instrumentation Amplifier

$$\frac{V_{OUT}}{V_{IN}} = \frac{R2 + 2R1}{R2} \times \frac{R4}{R3}$$

If $R1 = R5$, $R3 = R6$, and $R4 = R7$, then $A_V = 100$ for circuit shown.

Use low-drift resistors for good CMRR performance over temperature. Matching of $R3$ to $R6$ and $R4$ to $R7$ affects CMRR. Gain is adjusted through $R2$. CMRR is adjusted through $R7$. An improved circuit can be designed using the [RES11A-Q1](#), low-drift, precision, matched resistor pairs. [Figure 6-7](#) shows how a precise gain of 99 is easily implemented. The capacitors are optional and are used to improve noise performance, if needed.

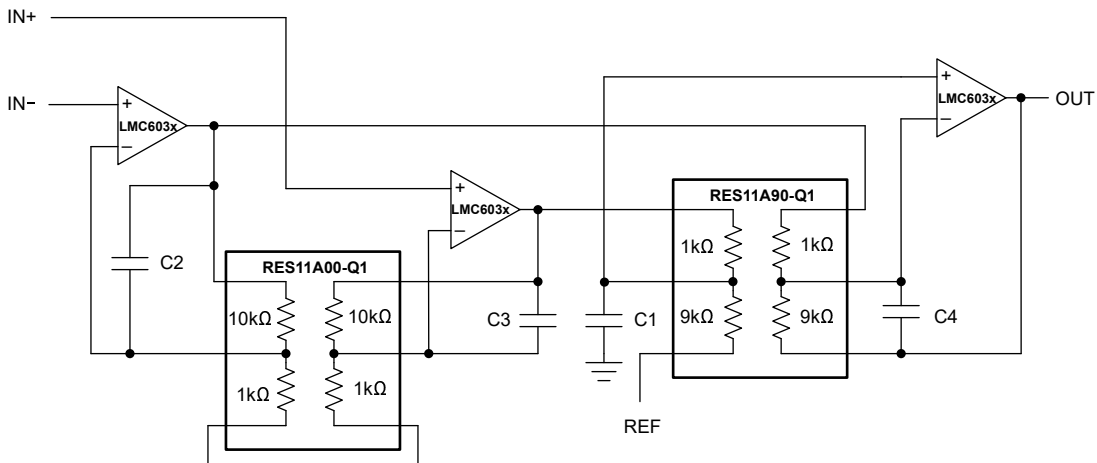
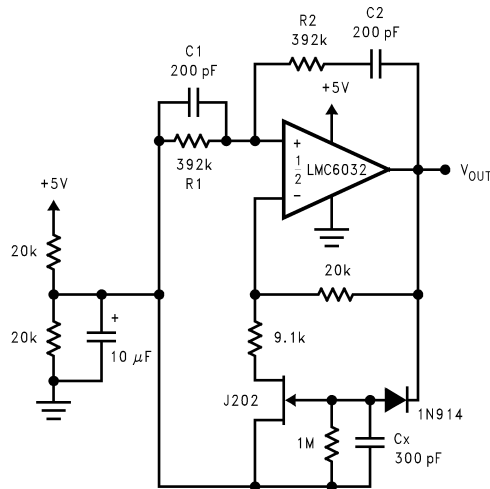

Figure 6-7. Improved Instrumentation Amplifier With RES11A



Oscillator frequency is determined by R1, R2, C1, and C2:

$$f_{OSC} = 1/2\pi RC$$

where $R = R1 = R2$ and $C = C1 = C2$.

Figure 6-8. Sine-Wave Oscillator

This circuit, as shown, oscillates at 2.0kHz with a peak-to-peak output swing of 4.0V.

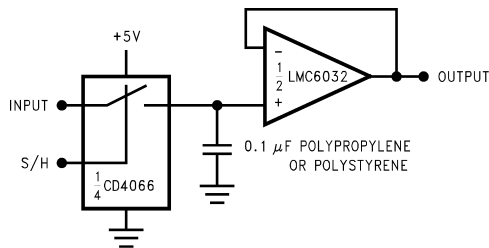

Figure 6-9. Low-Leakage Sample-and-Hold

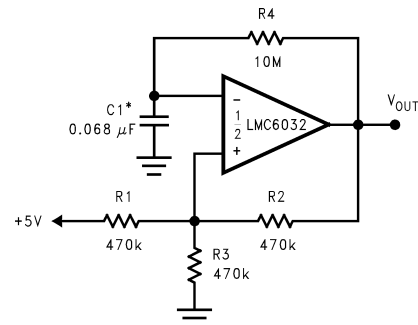

Figure 6-10. 1Hz Square-Wave Oscillator

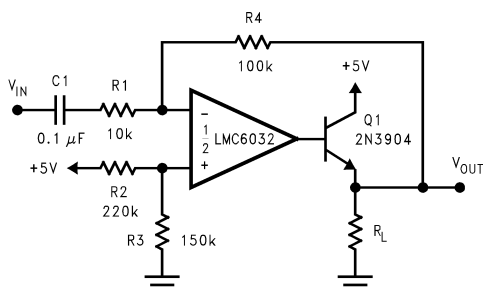
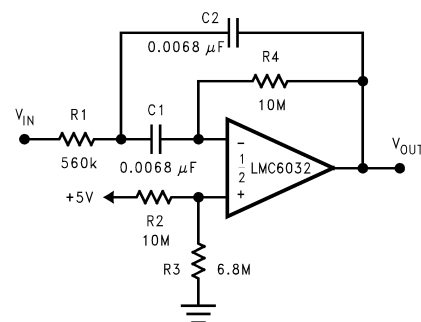

Figure 6-11. Power Amplifier



$$f_0 = 10\text{Hz}, Q = 2.1, \text{gain} = -8.8$$

Figure 6-12. 10Hz Bandpass Filter

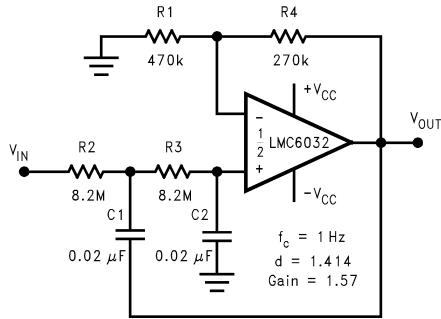
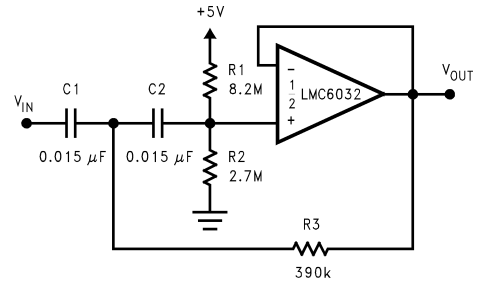
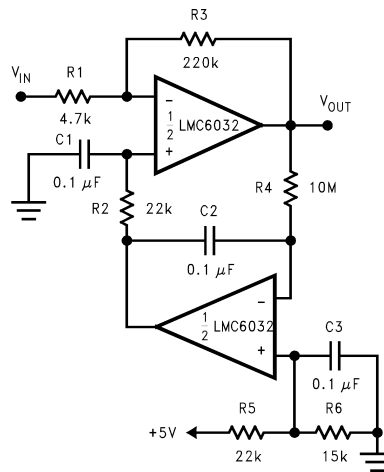

Figure 6-13. 1Hz Low-Pass Filter (Maximally Flat, Dual Supply Only)



$f_c = 10\text{Hz}$, $d = 0.895$, gain = 1, 2dB pass-band ripple

Figure 6-14. 10Hz High-Pass Filter



Gain = -46.8 Output offset voltage reduced to the level of the input offset voltage of the bottom amplifier (typically 1mV).

Figure 6-15. High-Gain Amplifier With Offset Voltage Reduction

6.3 Layout

6.3.1 Layout Guidelines

6.3.1.1 Printed Circuit Board Layout for High-Impedance Work

Generally, any circuit that operates with less than 1000pA of leakage current requires special layout of the printed circuit board (PCB). To take advantage of the ultra-low bias current of the LMC603x, typically less than 40fA, an excellent layout is essential. Fortunately, the techniques for obtaining low leakages are quite simple. Foremost, do not ignore the surface leakage of the PCB, even though the leakage can sometimes appear acceptably low, because under conditions of high humidity or dust or contamination, the surface leakage can be appreciable.

To minimize the effect of any surface leakage, lay out a ring of foil completely surrounding the LMC603x inputs and the terminals of capacitors, diodes, conductors, resistors, relay terminals, and so on, connected to the op amp inputs. See [Figure 6-16](#). To have a significant effect, place guard rings on both the top and bottom of the PCB. This PCB foil must then be connected to a voltage which is at the same voltage as the amplifier inputs, since no leakage current can flow between two points at the same potential. For example, a PCB trace-to-pad resistance of $10^{12}\Omega$, which is normally considered a very large resistance, can leak 5pA if the trace were a 5V bus adjacent to the pad of an input. This causes a 100 times degradation from the LMC603x actual performance. However, if a guard ring is held within 5mV of the inputs, then even a resistance of $10^{11}\Omega$ causes only 50fA of leakage current, or perhaps a minor (2:1) degradation of the amplifier performance. See [Figure 6-17](#), [Figure 6-18](#), [Figure 6-19](#) for typical connections of guard rings for standard op amp configurations. If both inputs are active and at high impedance, the guard can be tied to ground and still provide some protection; see [Figure 6-20](#).

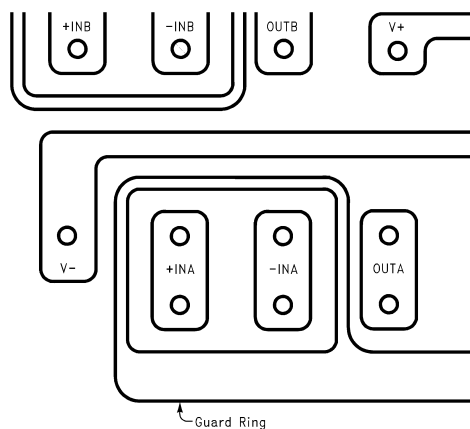

Figure 6-16. Example of Guard Ring in PCB Layout

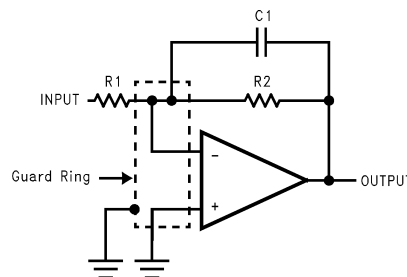

Figure 6-17. Inverting Amplifier Guard-Ring Connections

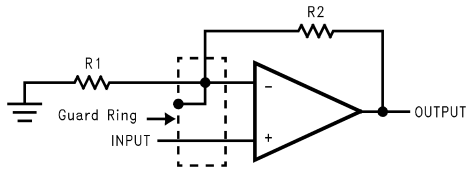

Figure 6-18. Noninverting Amplifier Guard-Ring Connections

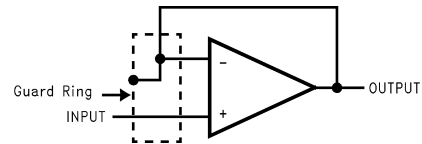

Figure 6-19. Follower Guard-Ring Connections

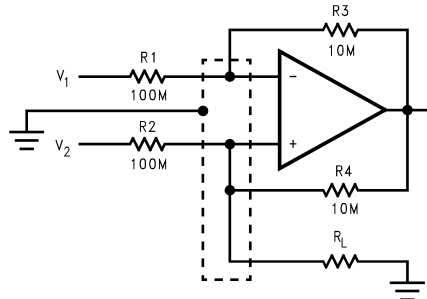
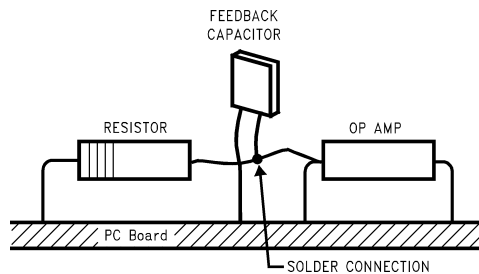

Figure 6-20. Howland Current-Pump Guard-Ring Connections

Be aware that when laying out a PCB for the sake of just a few circuits is inappropriate, there is another technique which is even better than a guard ring on a PCB. Do not insert the amplifier input pin into the board at all, but bend the pin up in the air and use only air as an insulator. Air is an excellent insulator. In this case you forgo some of the advantages of PCB construction, but the advantages of air are sometimes well worth the effort of using point-to-point up-in-the-air wiring. See [Figure 6-21](#).



Input pins are lifted out of PCB and soldered directly to components. All other pins connected to the PCB.

Figure 6-21. Air Wiring

7 Device and Documentation Support

TI offers an extensive line of development tools. Tools and software to evaluate the performance of the device, generate code, and develop solutions are listed below.

7.1 Receiving Notification of Documentation Updates

To receive notification of documentation updates, navigate to the device product folder on ti.com. Click on *Notifications* to register and receive a weekly digest of any product information that has changed. For change details, review the revision history included in any revised document.

7.2 Support Resources

TI E2E™ [support forums](#) are an engineer's go-to source for fast, verified answers and design help — straight from the experts. Search existing answers or ask your own question to get the quick design help you need.

Linked content is provided "AS IS" by the respective contributors. They do not constitute TI specifications and do not necessarily reflect TI's views; see TI's [Terms of Use](#).

Trademarks

TI E2E™ is a trademark of Texas Instruments.

All trademarks are the property of their respective owners.

7.3 Electrostatic Discharge Caution



This integrated circuit can be damaged by ESD. Texas Instruments recommends that all integrated circuits be handled with appropriate precautions. Failure to observe proper handling and installation procedures can cause damage.

ESD damage can range from subtle performance degradation to complete device failure. Precision integrated circuits may be more susceptible to damage because very small parametric changes could cause the device not to meet its published specifications.

7.4 Glossary

[TI Glossary](#) This glossary lists and explains terms, acronyms, and definitions.

8 Revision History

NOTE: Page numbers for previous revisions may differ from page numbers in the current version.

Changes from Revision C (March 2013) to Revision D (February 2024)	Page
• Added LMC6034 and related information.....	1
• Changed I_Q from 400 μ A to 375 μ A to match <i>Electrical Characteristics</i> in <i>Features</i>	1
• Changed high voltage gain from 12dB to 126dB (typo) in <i>Features</i>	1
• Added low noise and deleted low distortion in <i>Features</i>	1
• Added OPA928 higher-performance reference in <i>Description</i>	1
• Added <i>Pin Configuration and Functions</i>	2
• Added <i>Thermal Information</i>	5
• Changed parameter names to conform with new standards in <i>Electrical Characteristics</i>	6
• Changed input current noise specification from 0.0002pA/ $\sqrt{\text{Hz}}$ to 4fA/ $\sqrt{\text{Hz}}$ in <i>Electrical Characteristics</i>	6
• Changed total harmonic distortion specification from 0.01% to 0.2% in <i>Electrical Characteristics</i>	6
• Updated conditions in the header of <i>Typical Characteristics</i>	8
• Added input offset voltage vs common mode voltage and input bias current vs common mode voltage.....	8
• Updated description and circuit topology diagram in <i>Amplifier Topology</i>	11
• Added new instrumentation amplifier circuit using the RES11A to <i>Typical Applications</i>	15

Changes from Revision B (March 2013) to Revision C (March 2013)	Page
• Changed layout of National Data Sheet to TI format.....	15

9 Mechanical, Packaging, and Orderable Information

The following pages include mechanical, packaging, and orderable information. This information is the most current data available for the designated devices. This data is subject to change without notice and revision of this document. For browser-based versions of this data sheet, refer to the left-hand navigation.

PACKAGING INFORMATION

Orderable Device	Status (1)	Package Type	Package Drawing	Pins	Package Qty	Eco Plan (2)	Lead finish/ Ball material (6)	MSL Peak Temp (3)	Op Temp (°C)	Device Marking (4/5)	Samples
LMC6032IMX/NOPB	ACTIVE	SOIC	D	8	2500	RoHS & Green	SN	Level-1-260C-UNLIM	-40 to 85	LMC60 32IM	Samples
LMC6032IN/NOPB	ACTIVE	PDIP	P	8	40	RoHS & Green	NIPDAU	Level-1-NA-UNLIM	-40 to 85	LMC 6032IN	Samples
LMC6034IMX/NOPB	ACTIVE	SOIC	D	14	2500	RoHS & Green	SN	Level-1-260C-UNLIM	-40 to 85	LMC6034IM	Samples

(1) The marketing status values are defined as follows:

ACTIVE: Product device recommended for new designs.

LIFEBUY: TI has announced that the device will be discontinued, and a lifetime-buy period is in effect.

NRND: Not recommended for new designs. Device is in production to support existing customers, but TI does not recommend using this part in a new design.

PREVIEW: Device has been announced but is not in production. Samples may or may not be available.

OBSOLETE: TI has discontinued the production of the device.

(2) **RoHS:** TI defines "RoHS" to mean semiconductor products that are compliant with the current EU RoHS requirements for all 10 RoHS substances, including the requirement that RoHS substance do not exceed 0.1% by weight in homogeneous materials. Where designed to be soldered at high temperatures, "RoHS" products are suitable for use in specified lead-free processes. TI may reference these types of products as "Pb-Free".

RoHS Exempt: TI defines "RoHS Exempt" to mean products that contain lead but are compliant with EU RoHS pursuant to a specific EU RoHS exemption.

Green: TI defines "Green" to mean the content of Chlorine (Cl) and Bromine (Br) based flame retardants meet JS709B low halogen requirements of <=1000ppm threshold. Antimony trioxide based flame retardants must also meet the <=1000ppm threshold requirement.

(3) MSL, Peak Temp. - The Moisture Sensitivity Level rating according to the JEDEC industry standard classifications, and peak solder temperature.

(4) There may be additional marking, which relates to the logo, the lot trace code information, or the environmental category on the device.

(5) Multiple Device Markings will be inside parentheses. Only one Device Marking contained in parentheses and separated by a "-" will appear on a device. If a line is indented then it is a continuation of the previous line and the two combined represent the entire Device Marking for that device.

(6) Lead finish/Ball material - Orderable Devices may have multiple material finish options. Finish options are separated by a vertical ruled line. Lead finish/Ball material values may wrap to two lines if the finish value exceeds the maximum column width.

Important Information and Disclaimer:The information provided on this page represents TI's knowledge and belief as of the date that it is provided. TI bases its knowledge and belief on information provided by third parties, and makes no representation or warranty as to the accuracy of such information. Efforts are underway to better integrate information from third parties. TI has taken and continues to take reasonable steps to provide representative and accurate information but may not have conducted destructive testing or chemical analysis on incoming materials and chemicals. TI and TI suppliers consider certain information to be proprietary, and thus CAS numbers and other limited information may not be available for release.

In no event shall TI's liability arising out of such information exceed the total purchase price of the TI part(s) at issue in this document sold by TI to Customer on an annual basis.

TAPE AND REEL INFORMATION

QUADRANT ASSIGNMENTS FOR PIN 1 ORIENTATION IN TAPE

*All dimensions are nominal

Device	Package Type	Package Drawing	Pins	SPQ	Reel Diameter (mm)	Reel Width W1 (mm)	A0 (mm)	B0 (mm)	K0 (mm)	P1 (mm)	W (mm)	Pin1 Quadrant
LMC6032IMX/NOPB	SOIC	D	8	2500	330.0	12.4	6.5	5.4	2.0	8.0	12.0	Q1
LMC6034IMX/NOPB	SOIC	D	14	2500	330.0	16.4	6.5	9.35	2.3	8.0	16.0	Q1

TAPE AND REEL BOX DIMENSIONS

*All dimensions are nominal

Device	Package Type	Package Drawing	Pins	SPQ	Length (mm)	Width (mm)	Height (mm)
LMC6032IMX/NOPB	SOIC	D	8	2500	367.0	367.0	35.0
LMC6034IMX/NOPB	SOIC	D	14	2500	356.0	356.0	35.0

TUBE

*All dimensions are nominal

Device	Package Name	Package Type	Pins	SPQ	L (mm)	W (mm)	T (μm)	B (mm)
LMC6032IN/NOPB	P	PDIP	8	40	506	13.97	11230	4.32
LMC6032IN/NOPB	P	PDIP	8	40	502	14	11938	4.32

D (R-PDSO-G14)

PLASTIC SMALL OUTLINE



4211283-3/E 08/12

- NOTES:
- All linear dimensions are in millimeters.
 - This drawing is subject to change without notice.
 - Publication IPC-7351 is recommended for alternate designs.
 - Laser cutting apertures with trapezoidal walls and also rounding corners will offer better paste release. Customers should contact their board assembly site for stencil design recommendations. Refer to IPC-7525 for other stencil recommendations.
 - Customers should contact their board fabrication site for solder mask tolerances between and around signal pads.



D0008A

PACKAGE OUTLINE

SOIC - 1.75 mm max height

SMALL OUTLINE INTEGRATED CIRCUIT



4214825/C 02/2019

NOTES:

- Linear dimensions are in inches [millimeters]. Dimensions in parenthesis are for reference only. Controlling dimensions are in inches. Dimensioning and tolerancing per ASME Y14.5M.
- This drawing is subject to change without notice.
- This dimension does not include mold flash, protrusions, or gate burrs. Mold flash, protrusions, or gate burrs shall not exceed $.006$ [0.15] per side.
- This dimension does not include interlead flash.
- Reference JEDEC registration MS-012, variation AA.

EXAMPLE BOARD LAYOUT

D0008A

SOIC - 1.75 mm max height

SMALL OUTLINE INTEGRATED CIRCUIT



LAND PATTERN EXAMPLE
 EXPOSED METAL SHOWN
 SCALE:8X



SOLDER MASK DETAILS

4214825/C 02/2019

NOTES: (continued)

- 6. Publication IPC-7351 may have alternate designs.
- 7. Solder mask tolerances between and around signal pads can vary based on board fabrication site.

EXAMPLE STENCIL DESIGN

D0008A

SOIC - 1.75 mm max height

SMALL OUTLINE INTEGRATED CIRCUIT



SOLDER PASTE EXAMPLE
BASED ON .005 INCH [0.125 MM] THICK STENCIL
SCALE:8X

4214825/C 02/2019

NOTES: (continued)

8. Laser cutting apertures with trapezoidal walls and rounded corners may offer better paste release. IPC-7525 may have alternate design recommendations.
9. Board assembly site may have different recommendations for stencil design.

P (R-PDIP-T8)

PLASTIC DUAL-IN-LINE PACKAGE



- NOTES:
- A. All linear dimensions are in inches (millimeters).
 - B. This drawing is subject to change without notice.
 - C. Falls within JEDEC MS-001 variation BA.

IMPORTANT NOTICE AND DISCLAIMER

TI PROVIDES TECHNICAL AND RELIABILITY DATA (INCLUDING DATA SHEETS), DESIGN RESOURCES (INCLUDING REFERENCE DESIGNS), APPLICATION OR OTHER DESIGN ADVICE, WEB TOOLS, SAFETY INFORMATION, AND OTHER RESOURCES "AS IS" AND WITH ALL FAULTS, AND DISCLAIMS ALL WARRANTIES, EXPRESS AND IMPLIED, INCLUDING WITHOUT LIMITATION ANY IMPLIED WARRANTIES OF MERCHANTABILITY, FITNESS FOR A PARTICULAR PURPOSE OR NON-INFRINGEMENT OF THIRD PARTY INTELLECTUAL PROPERTY RIGHTS.

These resources are intended for skilled developers designing with TI products. You are solely responsible for (1) selecting the appropriate TI products for your application, (2) designing, validating and testing your application, and (3) ensuring your application meets applicable standards, and any other safety, security, regulatory or other requirements.

These resources are subject to change without notice. TI grants you permission to use these resources only for development of an application that uses the TI products described in the resource. Other reproduction and display of these resources is prohibited. No license is granted to any other TI intellectual property right or to any third party intellectual property right. TI disclaims responsibility for, and you will fully indemnify TI and its representatives against, any claims, damages, costs, losses, and liabilities arising out of your use of these resources.

TI's products are provided subject to [TI's Terms of Sale](#) or other applicable terms available either on [ti.com](https://www.ti.com) or provided in conjunction with such TI products. TI's provision of these resources does not expand or otherwise alter TI's applicable warranties or warranty disclaimers for TI products.

TI objects to and rejects any additional or different terms you may have proposed.

Mailing Address: Texas Instruments, Post Office Box 655303, Dallas, Texas 75265
Copyright © 2024, Texas Instruments Incorporated

Looking for pricing, stock, or lifecycle information?

Click below to explore more details on WIN SOURCE:

 [View LMC6034IM](#) on WIN SOURCE

 [Texas Instruments](#) Information

Optimize Your Supply Chain with WIN SOURCE Solutions

-  Global Sourcing Solution
-  Obsolete Management
-  Cost Control Management
-  Shortage Management
-  Alternative Solution
-  Excess Inventory Management