



**THE DATASHEET OF
LME49726MY/NOPB**



LME49726 High Current, Low Distortion, Rail-to-Rail Output Audio Operational Amplifier

Check for Samples: [LME49726](#)

FEATURES

- Rail-to-Rail Output
- Easily Drives 2k Ω Loads to within 4mV of Each Power Supply Voltage Rail
- Optimized for Superior Audio Signal Fidelity
- Output Short Circuit Protection
- High Output Drive (>300mA)
- Available in VSSOP Exposed-DAP Package

KEY SPECIFICATIONS

- Power Supply Voltage Range: 2.5 to 5.5 V
- Quiescent Current per Amplifier at 5V: 0.7 mA (Typ)
- THD+N, $A_V = 1$, $f_{IN} = 1\text{kHz}$, $R_L = 10\text{k}\Omega$:
 - ($V_{OUT} = 3.5V_{P-P}$, $V_{DD} = 5.0V$): 0.00008 % (Typ)
 - ($V_{OUT} = 1.5V_{P-P}$, $V_{DD} = 2.5V$): 0.00002 % (Typ)
- Equivalent Input Noise ($f = 10\text{k}$): 8.3 nV/ $\sqrt{\text{Hz}}$ (Typ)
- Slew Rate: $\pm 3.7\text{ V}/\mu\text{s}$ (Typ)
- Gain Bandwidth Product: 6.25 MHz (Typ)
- Open Loop Gain ($R_L = 10\text{k}\Omega$): 120 dB (Typ)
- Input Bias Current: 0.2 pA (Typ)
- Input Offset Voltage: 0.5 mV (Typ)
- PSRR (DC): 104 dB (Typ)

APPLICATIONS

- Portable Audio Amplification
- Preamplifiers and Multimedia
- Equalization and Crossover Networks
- Line Drivers and Receivers
- Active Filters
- DAC I–V Converter Gain Stage
- ADC Front-End Signal Conditioning

DESCRIPTION

The LME49726 is a low distortion, low noise rail-to-rail output audio operational amplifier optimized and fully specified for high performance, high fidelity applications. The LME49726 delivers superior audio signal amplification for outstanding audio performance. The LME49726 has a very low THD+N to easily satisfy demanding audio applications. To ensure that the most challenging loads are driven without compromise, the LME49726 provides output current greater than 300mA at 5V. Further, dynamic range is maximized by an output that drives 2k Ω loads to within 4mV of either power supply voltage.

The LME49726 has a supply range of 2.5V to 5.5V. Over this supply range the LME49726's input circuitry maintains excellent common-mode and power supply rejection, as well as maintaining its low input bias current. The LME49726 is unity gain stable.

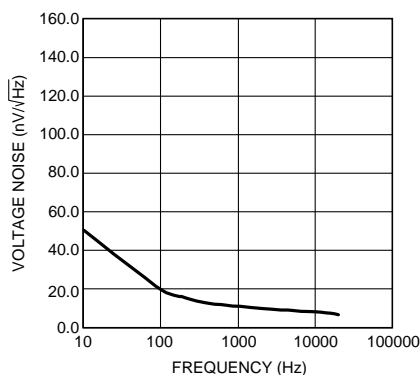

Figure 1. Input Voltage Noise vs Frequency
 $V_{DD} = 3V$

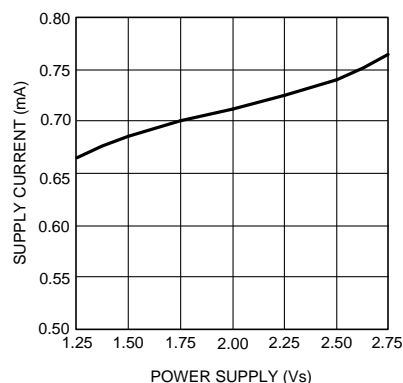

Figure 2. Supply Current vs Supply Voltage per Amplifier, $R_L = \text{No Load}$, $A_V = -1$



Please be aware that an important notice concerning availability, standard warranty, and use in critical applications of Texas Instruments semiconductor products and disclaimers thereto appears at the end of this data sheet.

All trademarks are the property of their respective owners.

Typical Connections

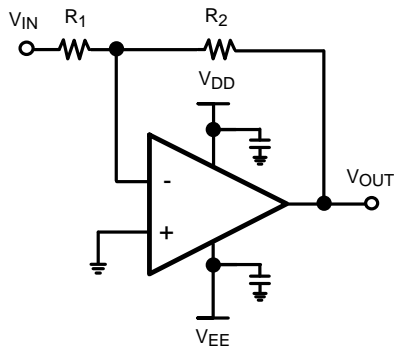

Figure 3. Inverting Configuration Split Supplies

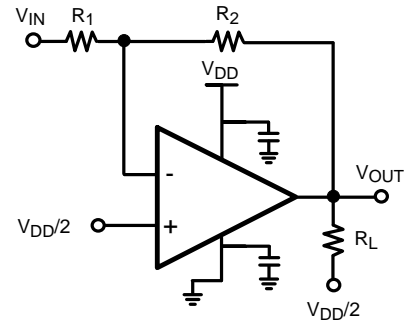

Figure 4. Inverting Configuration Single Supplies

Connection Diagram

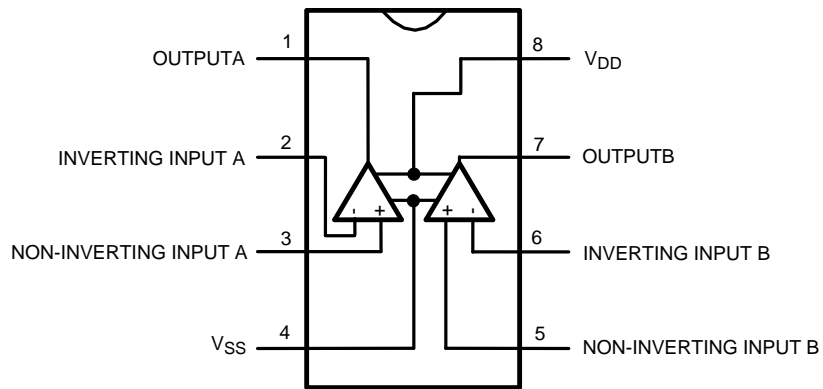

Figure 5. See Package Number DGN0008A



These devices have limited built-in ESD protection. The leads should be shorted together or the device placed in conductive foam during storage or handling to prevent electrostatic damage to the MOS gates.

ABSOLUTE MAXIMUM RATINGS⁽¹⁾⁽²⁾⁽³⁾

Power Supply Voltage	$V_S = V_{SS} - V_{DD}$	6V
Storage Temperature		-65°C to 150°C
Input Voltage		$(V_{SS}) - 0.7V$ to $(V_{DD}) + 0.7V$
Output Short Circuit ⁽⁴⁾		Continuous
Power Dissipation		Internally Limited
ESD Rating ⁽⁵⁾		2000V
ESD Rating ⁽⁶⁾		200V
Junction Temperature		150°C
Thermal Resistance	θ_{JA} (DGN0008A)	72°C/W

- (1) Absolute Maximum Ratings indicate limits beyond which damage to the device may occur, including inoperability and degradation of device reliability and/or performance. Functional operation of the device and/or non-degradation at the Absolute Maximum Ratings or other conditions beyond those indicated in the Recommended Operating Conditions is not implied. The Recommended Operating Conditions indicate conditions at which the device is functional and the device should not be operated beyond such conditions. All voltages are measured with respect to the ground pin, unless otherwise specified.
- (2) The Electrical Characteristics tables list specifications under the listed Recommended Operating Conditions except as otherwise modified or specified by the Electrical Characteristics Conditions and/or Notes. Typical specifications are estimations only and are not ensured.
- (3) If Military/Aerospace specified devices are required, please contact the Texas Instruments Sales Office/ Distributors for availability and specifications.
- (4) The maximum power dissipation must be derated at elevated temperatures and is dictated by T_{JMAX} , θ_{JA} , and the ambient temperature, T_A . The maximum allowable power dissipation is $P_{DMAX} = (T_{JMAX} - T_A) / \theta_{JA}$ or the number given in Absolute Maximum Ratings, whichever is lower.
- (5) Human body model, applicable std. JESD22-A114C.
- (6) Machine model, applicable std. JESD22-A115-A.

OPERATING RATINGS⁽¹⁾

Temperature Range	$T_{MIN} \leq T_A \leq T_{MAX}$	$-40^\circ\text{C} \leq T_A \leq 125^\circ\text{C}$
Supply Voltage Range		$2.5V \leq V_S \leq 5.5V$

- (1) Absolute Maximum Ratings indicate limits beyond which damage to the device may occur, including inoperability and degradation of device reliability and/or performance. Functional operation of the device and/or non-degradation at the Absolute Maximum Ratings or other conditions beyond those indicated in the Recommended Operating Conditions is not implied. The Recommended Operating Conditions indicate conditions at which the device is functional and the device should not be operated beyond such conditions. All voltages are measured with respect to the ground pin, unless otherwise specified.

ELECTRICAL CHARACTERISTICS ($V_{DD} = 5.0V$ and $V_{DD} = 2.5V$)

The following specifications apply for the circuit shown in Figure 1. $V_{DD} = 5.0V$ and $V_{DD} = 2.5V$, $V_{SS} = 0.0V$, $V_{CM} = V_{DD}/2$, $R_L = 10k\Omega$, $C_{LOAD} = 20pF$, $f_{IN} = 1kHz$, $BW = 20\text{--}20kHz$, and $T_A = 25^\circ C$, unless otherwise specified.

Symbol	Parameter	Conditions	LME49726		Units (Limits)
			Typical ⁽¹⁾	Limit ⁽²⁾	
THD+N	Total Harmonic Distortion + Noise	$A_V = -1$, $V_{OUT} = 3.5V_{p-p}$, $V_{DD} = 5V$ $R_L = 600\Omega$ $R_L = 2k\Omega$ $R_L = 10k\Omega$	0.0008 0.0002 0.00008		% % %
		$A_V = -1$, $V_{OUT} = 1.5V_{p-p}$, $V_{DD} = 2.5V$ $R_L = 600\Omega$ $R_L = 2k\Omega$ $R_L = 10k\Omega$	0.001 0.0008 0.0002	% % %	
GBWP	Gain Bandwidth Product		6.25	5.0	MHz (min)
SR	Slew Rate	$A_V = +1$, $R_L = 10k\Omega$	3.7	2.5	V/ μs (min)
t_s	Settling time	$A_V = 1V$ step 0.1% error range 0.001% error range	800		ns
			1.2		μs
e_N	Equivalent Input Noise Voltage	$f_{BW} = 20Hz$ to $20kHz$ (A-weighted)	0.7	1.25	μV_{RMS} (max)
e_N	Equivalent Input Noise Density	$f = 10kHz$	8.3		nV/ \sqrt{Hz}
		$f = 1kHz$	10		nV/ \sqrt{Hz}
		$f = 100Hz$	24		nV/ \sqrt{Hz}
i_N	Current Noise Density	$f = 1kHz$	0.75		pA/ \sqrt{Hz}
V_{OS}	Input Offset Voltage	$V_{IN} = V_{DD}/2$, $V_O = V_{DD}/2$, $A_V = 1$	0.5	2.25	mV (max)
$\Delta V_{OS}/\Delta Temp$	Average Input Offset Voltage Drift vs Temperature	$40^\circ C \leq T_A \leq 85^\circ C$	1.2		$\mu V/^\circ C$
PSRR	Power Supply Rejection Ratio	2.5 to 5.5V, $V_{CM} = 0$, $V_{DD}/2$	104	85	dB (min)
ISO _{CH-CH}	Channel-to-Channel Isolation	$f_{IN} = 1kHz$	94		dB
I_B	Input Bias Current	$V_{CM} = V_{DD}/2$	± 0.2		pA
$\Delta I_{OS}/\Delta Temp$	Input Bias Current Drift vs Temperature	$-40^\circ C \leq T_A \leq 85^\circ C$	35		nA/ $^\circ C$
I_{OS}	Input Offset Current	$V_{CM} = V_{DD}/2$	± 0.2		pA
V_{IN-CM}	Common-Mode Input Voltage Range			$V_{DD}-1.6$ $V_{SS}+0.1$	V (min)
CMRR	Common Mode Rejection Ratio	$0.1V < V_{DD} - 1.6V$	95	80	dB (min)
1/f	1/f Corner Frequency		2		kHz
A_{VOL}	Open-Loop Voltage Gain	$V_{OUT} = V_{DD}/2$	120	100	dB (min)
$V_{OUTSWING}$	Maximum Output Voltage Swing	$R_L = 2k\Omega$ to $V_{DD}/2$	$V_{DD}-0.004$ $V_{SS}+0.004$		V (min) V (max)
		$R_L = 16\Omega$ to $V_{DD}/2$	$V_{DD}-0.33$ $V_{SS}+0.33$		V (min) V (max)
I_{OUT}	Output Current	$V_{OUT} = 5V$, $V_{DD} = 5V$	350		mA
		$V_{OUT} = 2.5V$, $V_{DD} = 2.5V$	160		mA
I_S	Quiescent Current per Amplifier	$I_{OUT} = 0mA$, $V_{DD} = 5V$	0.7	1.1	mA (max)
		$I_{OUT} = 0mA$, $V_{DD} = 2.5V$	0.64	1.0	mA (max)

(1) Typical values represent most likely parametric norms at $T_A = +25^\circ C$, and at the Recommended Operation Conditions at the time of product characterization and are not ensured.

(2) Datasheet min/max specification limits are specified by test or statistical analysis.

TYPICAL PERFORMANCE CHARACTERISTICS

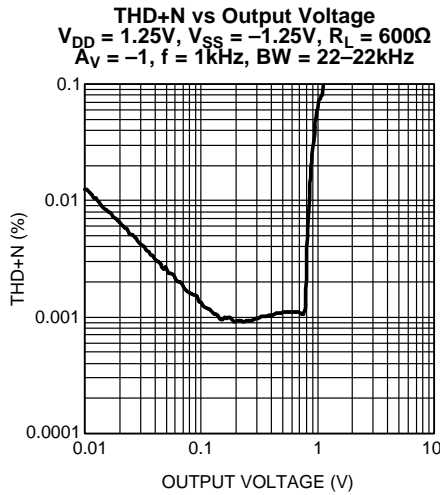

Figure 6.

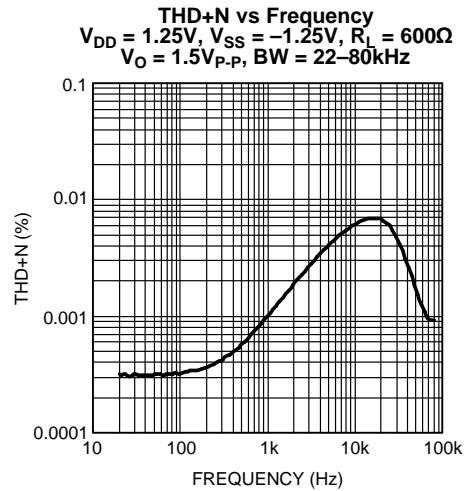

Figure 7.

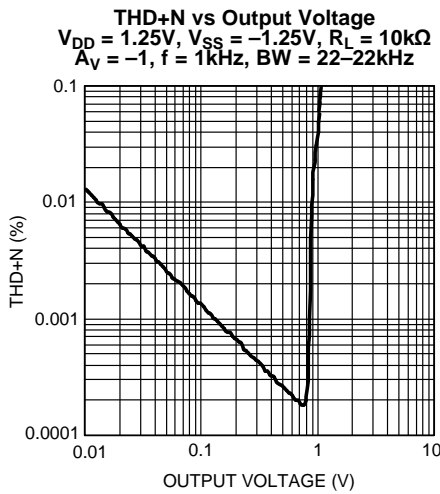

Figure 8.

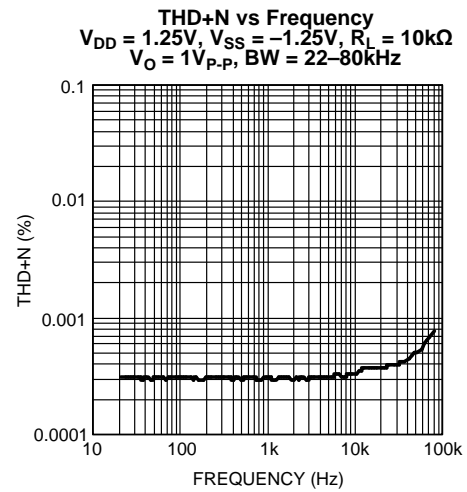

Figure 9.

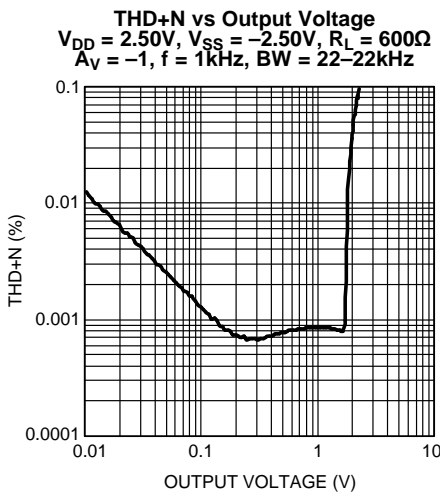

Figure 10.

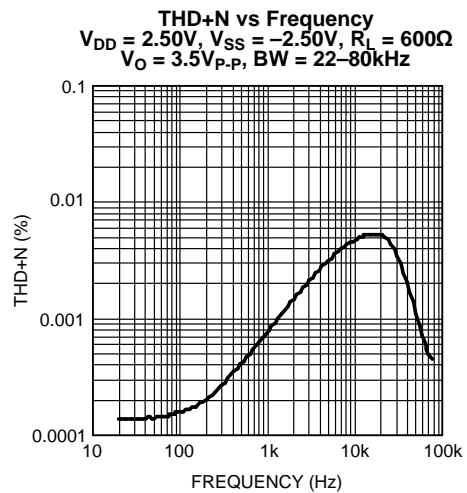

Figure 11.

TYPICAL PERFORMANCE CHARACTERISTICS (continued)

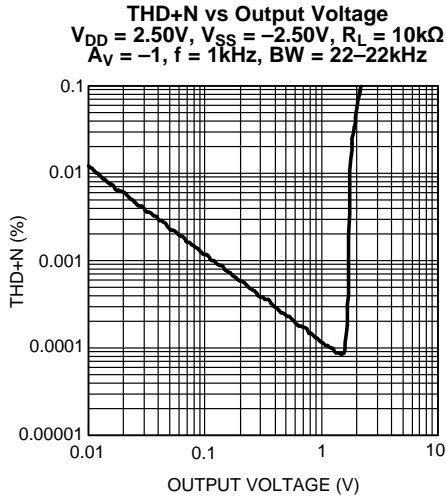

Figure 12.

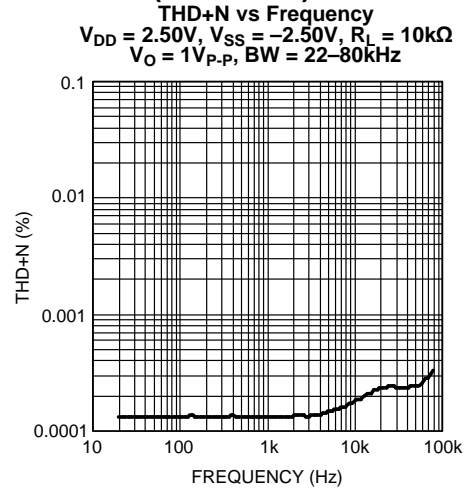

Figure 13.

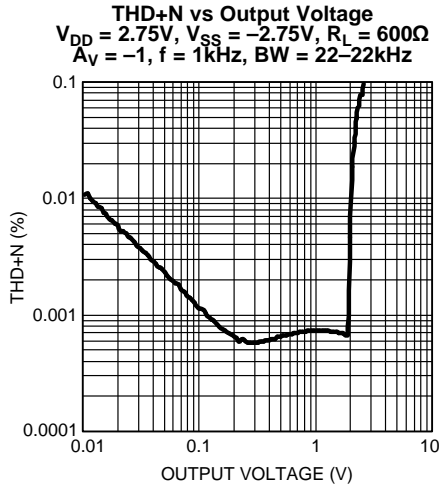

Figure 14.

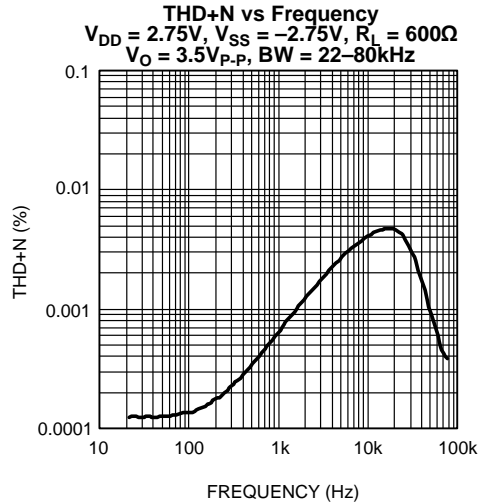

Figure 15.

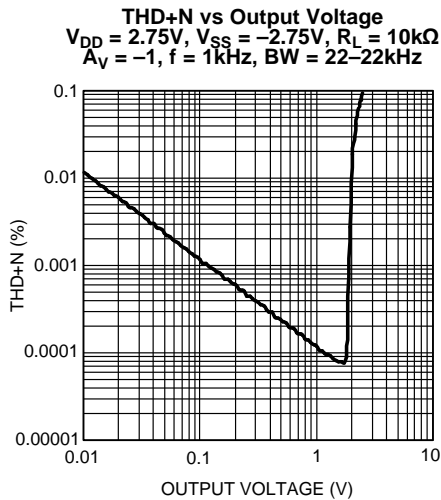

Figure 16.

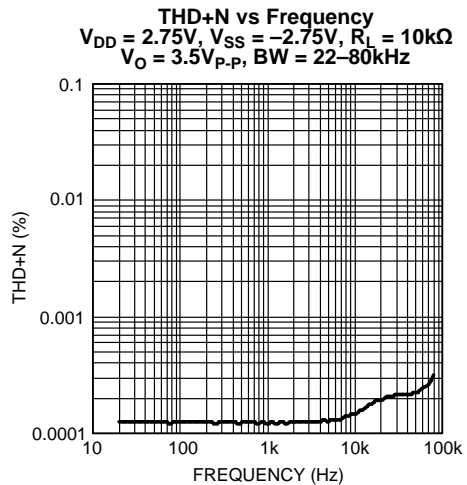

Figure 17.

TYPICAL PERFORMANCE CHARACTERISTICS (continued)

PSRR+ vs Frequency
 $V_{DD} = 1.25V, V_{SS} = -1.25V, V_{RIPPLE} = 200mV_{P-P}$
 Input terminated, BW = 22–80kHz

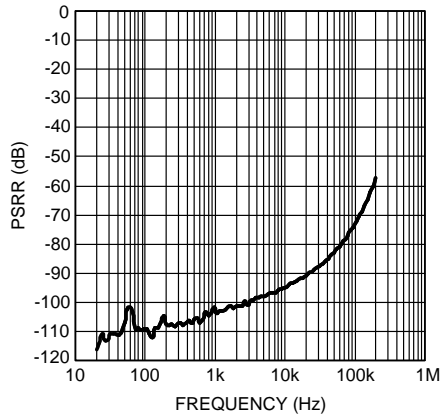

Figure 18.

PSRR- vs Frequency
 $V_{DD} = 1.25V, V_{SS} = -1.25V, V_{RIPPLE} = 200mV_{P-P}$
 Input terminated, BW = 22–80kHz

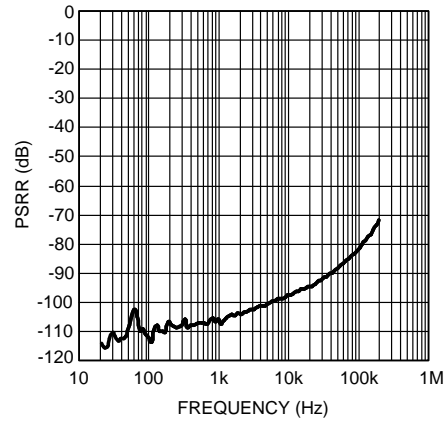

Figure 19.

PSRR+ vs Frequency
 $V_{DD} = 2.50V, V_{EE} = -2.50V, V_{RIPPLE} = 200mV_{P-P}$
 Input terminated, BW = 22–80kHz

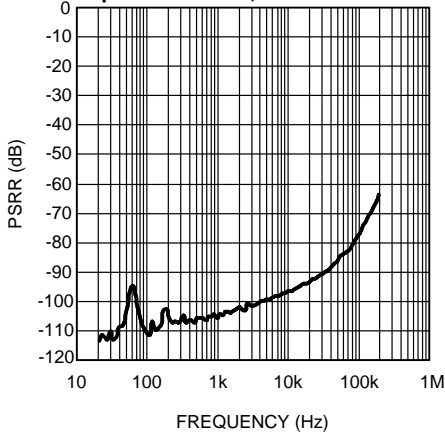

Figure 20.

PSRR- vs Frequency
 $V_{DD} = 2.50V, V_{SS} = -2.50V, V_{RIPPLE} = 200mV_{P-P}$
 Input terminated, BW = 22–80kHz

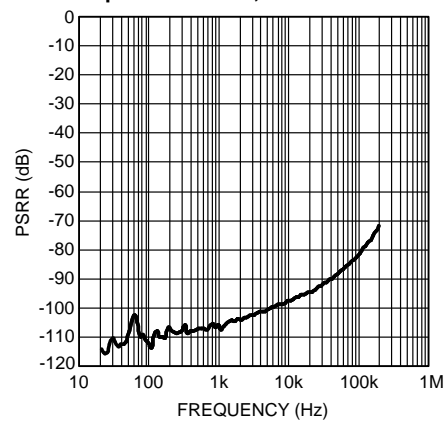

Figure 21.

PSRR+ vs Frequency
 $V_{DD} = 2.75V, V_{SS} = -2.75V, V_{RIPPLE} = 200mV_{P-P}$
 Input terminated, BW = 22–80kHz

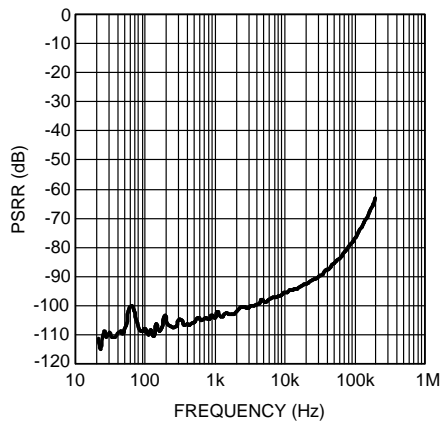

Figure 22.

PSRR- vs Frequency
 $V_{DD} = 2.75V, V_{SS} = -2.75V, V_{RIPPLE} = 200mV_{P-P}$
 Input terminated, BW = 22–80kHz

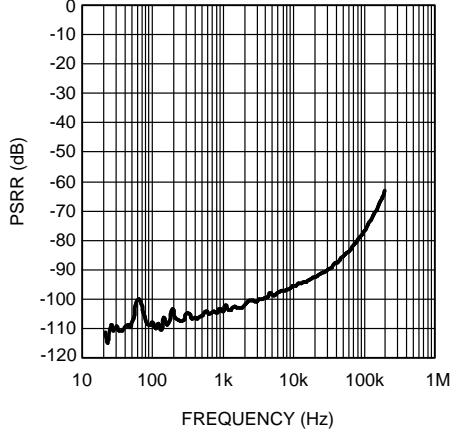

Figure 23.

TYPICAL PERFORMANCE CHARACTERISTICS (continued)

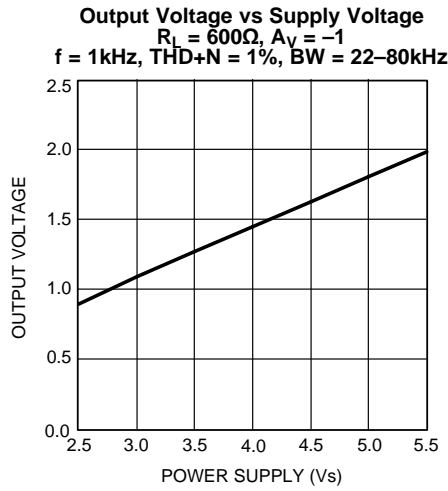

Figure 24.

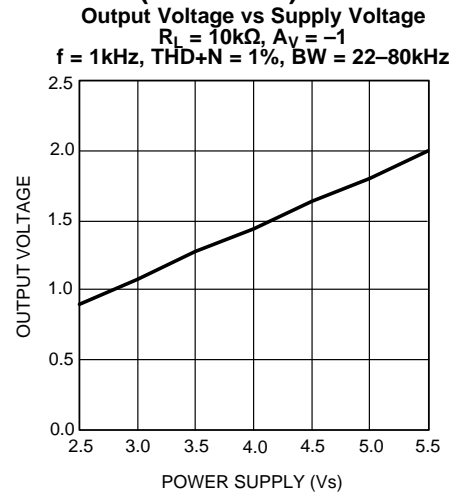

Figure 25.

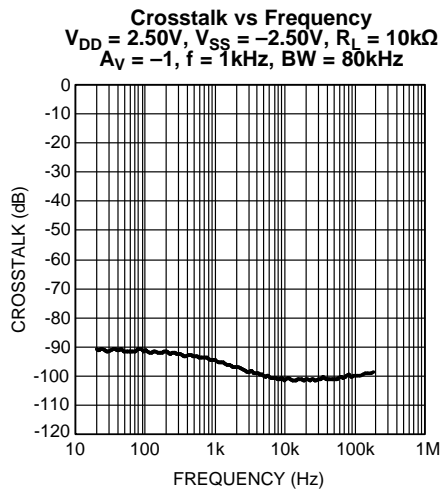

Figure 26.

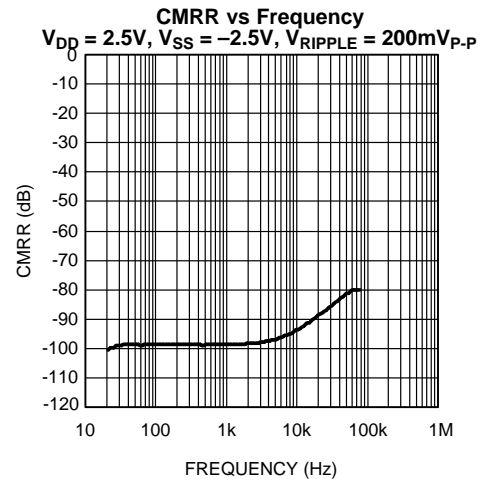

Figure 27.

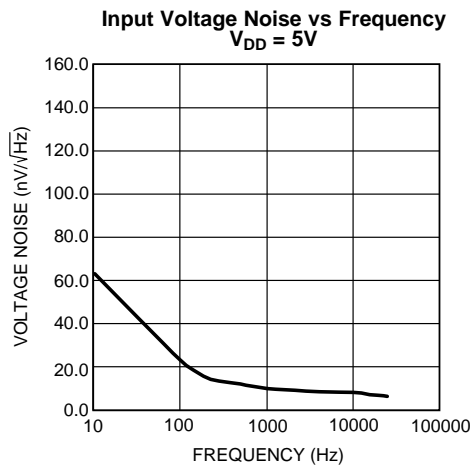

Figure 28.

APPLICATION INFORMATION

DISTORTION MEASUREMENTS

The vanishingly low residual distortion produced by LME49726 is below the capabilities of all commercially available equipment. This makes distortion measurements just slightly more difficult than simply connecting a distortion meter to the amplifier's inputs and outputs. The solution, however, is quite simple: an additional resistor. Adding this resistor extends the resolution of the distortion measurement equipment.

The LME49726's low residual is an input referred internal error. As shown in Figure 29, adding the 10Ω resistor connected between the amplifier's inverting and non-inverting inputs changes the amplifier's noise gain. The result is that the error signal (distortion) is amplified by a factor of 101. Although the amplifier's closed-loop gain is unaltered, the feedback available to correct distortion errors is reduced by 101. To ensure minimum effects on distortion measurements, keep the value of R1 low as shown in Figure 29.

This technique is verified by duplicating the measurements with high closed loop gain and/or making the measurements at high frequencies. Doing so, produces distortion components that are within measurement equipment capabilities. This datasheet's THD+N and IMD values were generated using the above described circuit connected to an Audio Precision System Two Cascade.

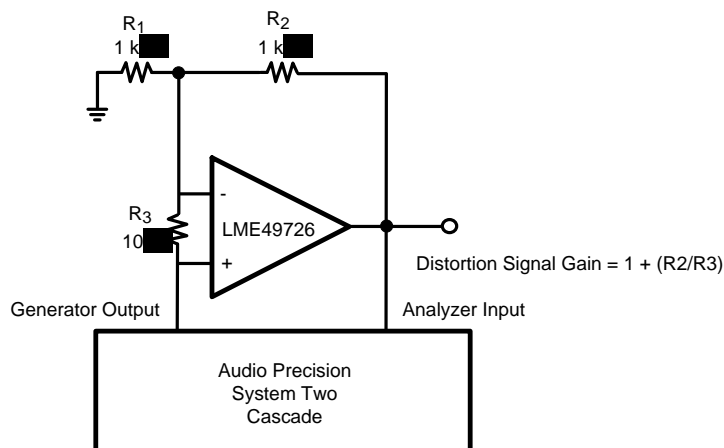

Figure 29. THD+N and IMD Distortion Test Circuit

OPERATING RATINGS AND BASIC DESIGN GUIDELINES

The LME49726 has a supply voltage range from +2.5V to +5.5V single supply or ±1.25 to ±2.75V dual supply.

Bypassed capacitors for the supplies should be placed as close to the amplifier as possible. This will help minimize any inductance between the power supply and the supply pins. In addition to a 10μF capacitor, a 0.1μF capacitor is also recommended in CMOS amplifiers.

The amplifier's inputs lead lengths should also be as short as possible. If the op amp does not have a bypass capacitor, it may oscillate.

BASIC AMPLIFIER CONFIGURATIONS

The LME49726 may be operated with either a single supply or dual supplies. Figure 2 shows the typical connection for a single supply inverting amplifier. The output voltage for a single supply amplifier will be centered around the common-mode voltage, V_{CM} . Note, the voltage applied to the V_{CM} insures the output stays above ground. Typically, the V_{CM} should be equal to $V_{DD}/2$. This is done by putting a resistor divider circuit at this node, see Figure 30.

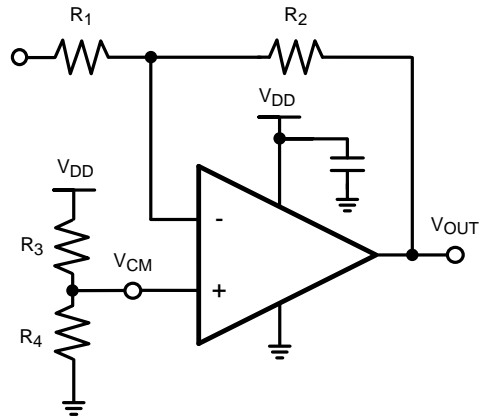

Figure 30. Single Supply Inverting Op Amp

Figure 31 shows the typical connection for a dual supply inverting amplifier. The output voltage is centered on zero.

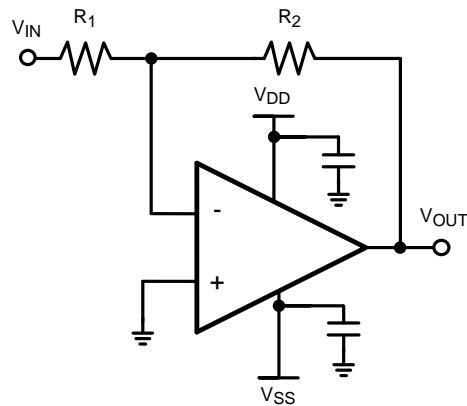

Figure 31. Dual Supply Inverting Configuration

Figure 32 shows the typical connection for the Buffer Amplifier or also called a Voltage Follower. The Buffer is a unity gain stable amplifier.

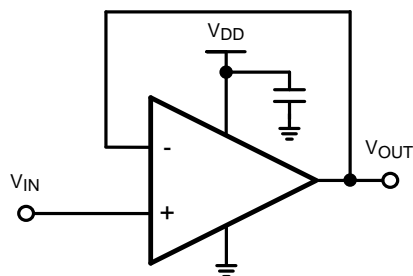
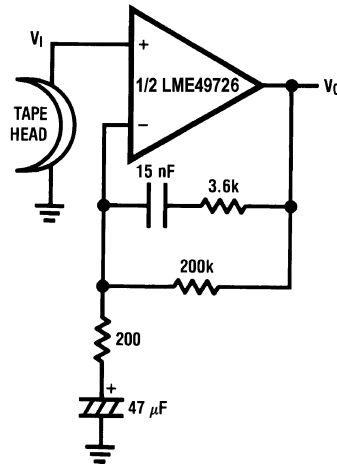

Figure 32. Unity-Gain Buffer Configuration

Typical Applications



$A_V = 34.5$
 $F = 1 \text{ kHz}$
 $E_n = 0.38 \mu\text{V}$
 A Weighted

Figure 33. NAB Preamp

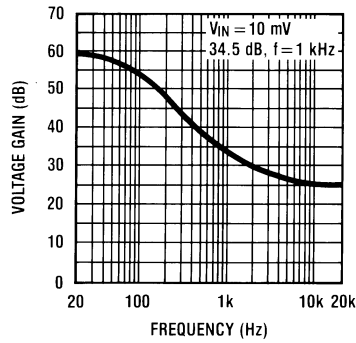

$A_V = 34.5$
 $F = 1 \text{ kHz}$
 $E_n = 0.38 \mu\text{V}$
 A Weighted

Figure 34. NAB Preamp Voltage Gain vs Frequency

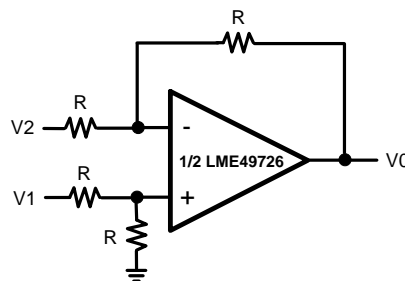

$V_O = V_1 - V_2$

Figure 35. Balanced to Single Ended Converter

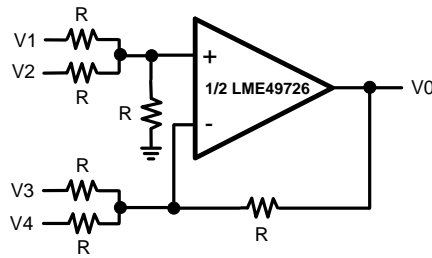

$$V_O = V_1 + V_2 - V_3 - V_4$$

Figure 36. Adder/Subtractor

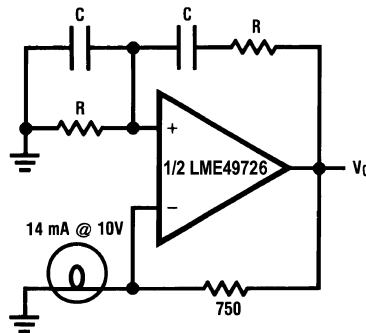

$$f_0 = \frac{1}{2\pi RC}$$

Figure 37. Sine Wave Oscillator

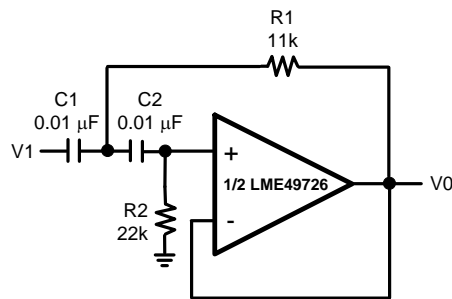

if $C_1 = C_2 = C$

$$R_1 = \frac{\sqrt{2}}{2\omega_0 C}$$

$$R_2 = 2 \cdot R_1$$

Illustration is $f_0 = 1 \text{ kHz}$

Figure 38. Second Order High Pass Filter (Butterworth)

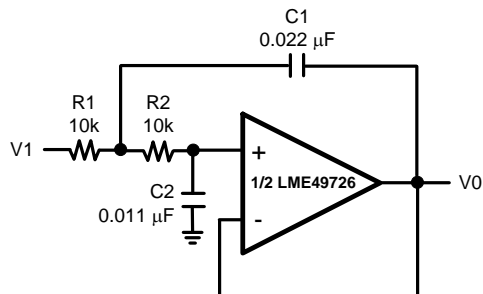

if $R1 = R2 = R$

$$C1 = \frac{\sqrt{2}}{\omega_0 R}$$

$$C2 = \frac{C1}{2}$$

Illustration is $f_0 = 1 \text{ kHz}$

Figure 39. Second Order Low Pass Filter (Butterworth)

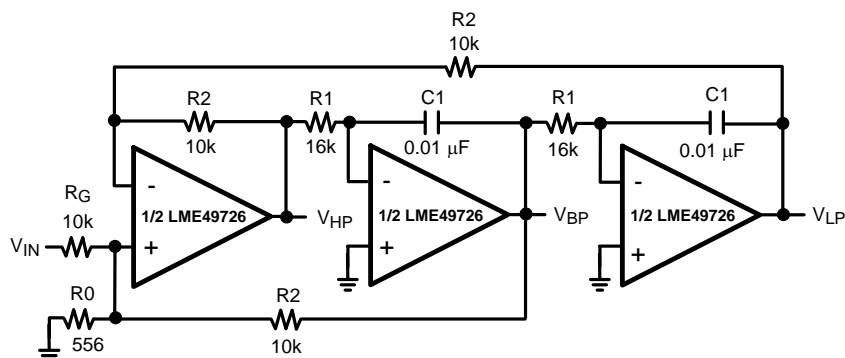

$$f_0 = \frac{1}{2\pi C1 R1}, Q = \frac{1}{2} \left(1 + \frac{R2}{R0} + \frac{R2}{RG} \right), A_{BP} = Q A_{LP} = Q A_{LH} = \frac{R2}{RG}$$

Illustration is $f_0 = 1 \text{ kHz}, Q = 10, A_{BP} = 1$

Figure 40. State Variable Filter

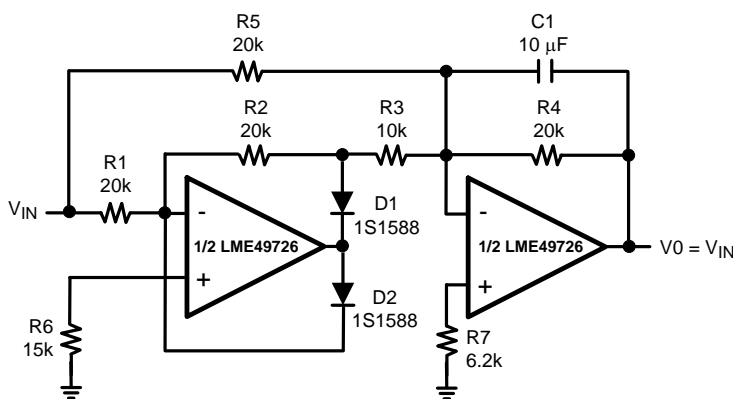

Figure 41. AC/DC Converter

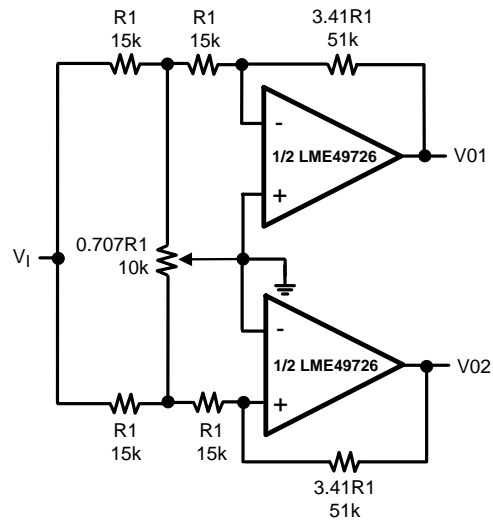

Figure 42. 2 Channel Panning Circuit (Pan Pot)

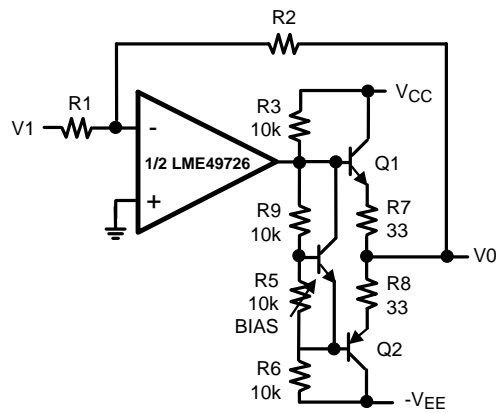
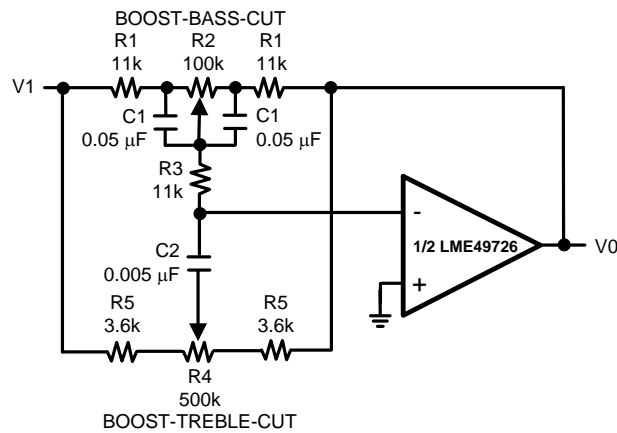

Figure 43. Line Driver



$$f_L = \frac{1}{2\pi R_2 C_1}, f_{LB} = \frac{1}{2\pi R_1 C_1}$$

$$f_H = \frac{1}{2\pi R_5 C_2}, f_{HB} = \frac{1}{2\pi(R_1 + R_5 + 2R_3)C_2}$$

Illustration is:

$$f_L = 32 \text{ Hz}, f_{LB} = 320 \text{ Hz}$$

$$f_H = 11 \text{ kHz}, f_{HB} = 1.1 \text{ kHz}$$

Figure 44. Tone Control

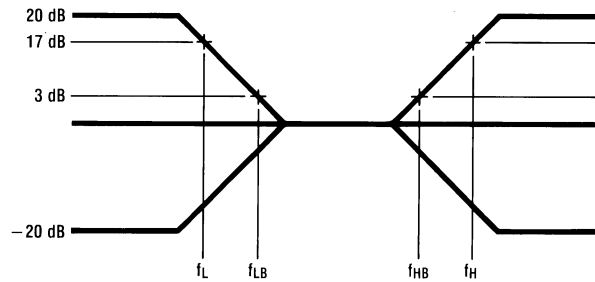
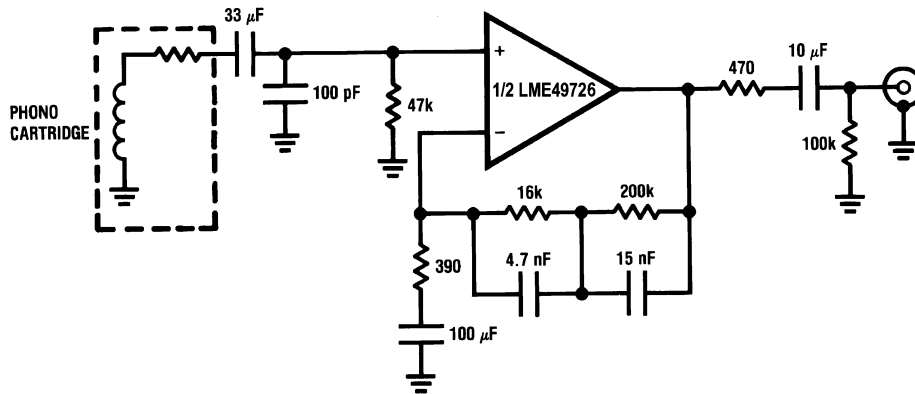
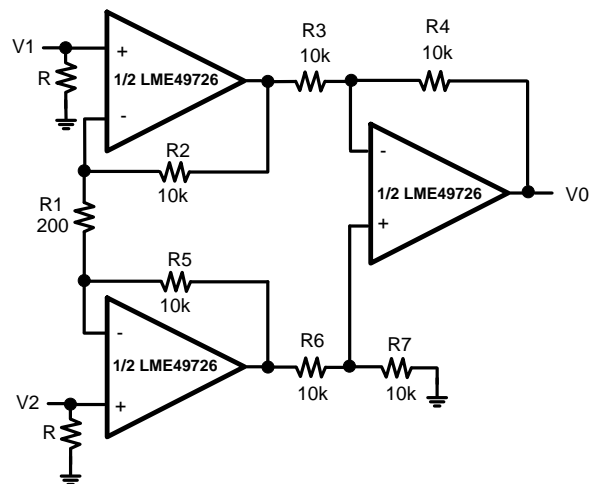

Figure 45.



$A_v = 35 \text{ dB}$
 $E_n = 0.33 \mu\text{V}$
 $S/N = 90 \text{ dB}$
 $f = 1 \text{ kHz}$
 A Weighted
 A Weighted, $V_{IN} = 10 \text{ mV}$
 @ $f = 1 \text{ kHz}$

Figure 46.



If $R_2 = R_5, R_3 = R_6, R_4 = R_7$

$$V_0 = \left(1 + \frac{2R_2}{R_1}\right) \frac{R_4}{R_3} (V_2 - V_1)$$
 Illustration is:

$$V_0 = 101(V_2 - V_1)$$

Figure 47. Balanced Input Mic Amp

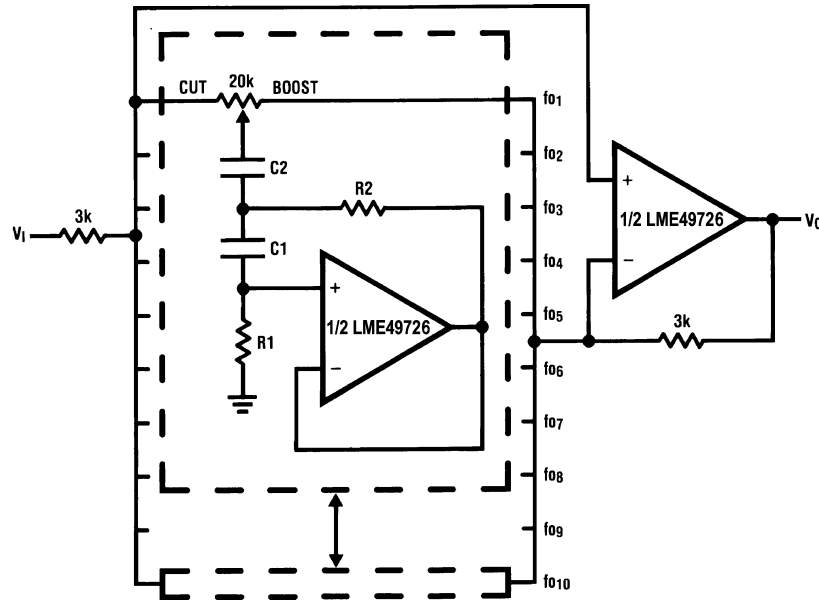

Figure 48.

fo (Hz)	C ₁	C ₂	R ₁	R ₂
32	0.12μF	4.7μF	75kΩ	500Ω
64	0.056μF	3.3μF	68kΩ	510Ω
125	0.033μF	1.5μF	62kΩ	510Ω
250	0.015μF	0.82μF	68kΩ	470Ω
500	8200pF	0.39μF	62kΩ	470Ω
1k	3900pF	0.22μF	68kΩ	470Ω
2k	2000pF	0.1μF	68kΩ	470Ω
4k	1100pF	0.056μF	62kΩ	470Ω
8k	510pF	0.022μF	68kΩ	510Ω
16k	330pF	0.012μF	51kΩ	510Ω

At volume of change = ±12 dB Q = 1.

LME49726 Bill of Materials

Description	Designator	Part Number	Manufacturer	Quantity/Brd
Ceramic Capacitor 0.1uF, 10%, 50V 0805 SMD	C1, C2, C5–C8	08055C104KAT2A	AVX	2
Tantalum Capacitor 2.2uF, 10%, 20V, A-size	C9, C11	T491A225K020AT	Kemet	Not Stuff
Tantalum Capacitor 10uF, 10%, 20V, B-size	C3, C4	T491B106K020AT	Kemet	2
Resistor 0Ω, 1/8W 1% 0805 SMD	R1, R4, R6, R9, R13, R14	CRCW08050000Z0EA	Vishay	6
Header, 2-Pin	JP1, JP2, JP3, JP4	HDR1X2	Header 2	4
Header, 3-Pin	JP5	HDR1X3	Header 3	1
Resistor 10kΩ, 1/8W 1% 0805 SMD	R2, R3, R7, R8	CRCW080510K0FKEA	Vishay	4
Dual Rail-to-Rail Op Amp	U1	LME49726	Texas Instruments	1
Resistor 100meg/open 1/8W 0805 SMD	R5, R10, R11, R12	OPEN N/A	N/A	0

LME49726 Board Circuit

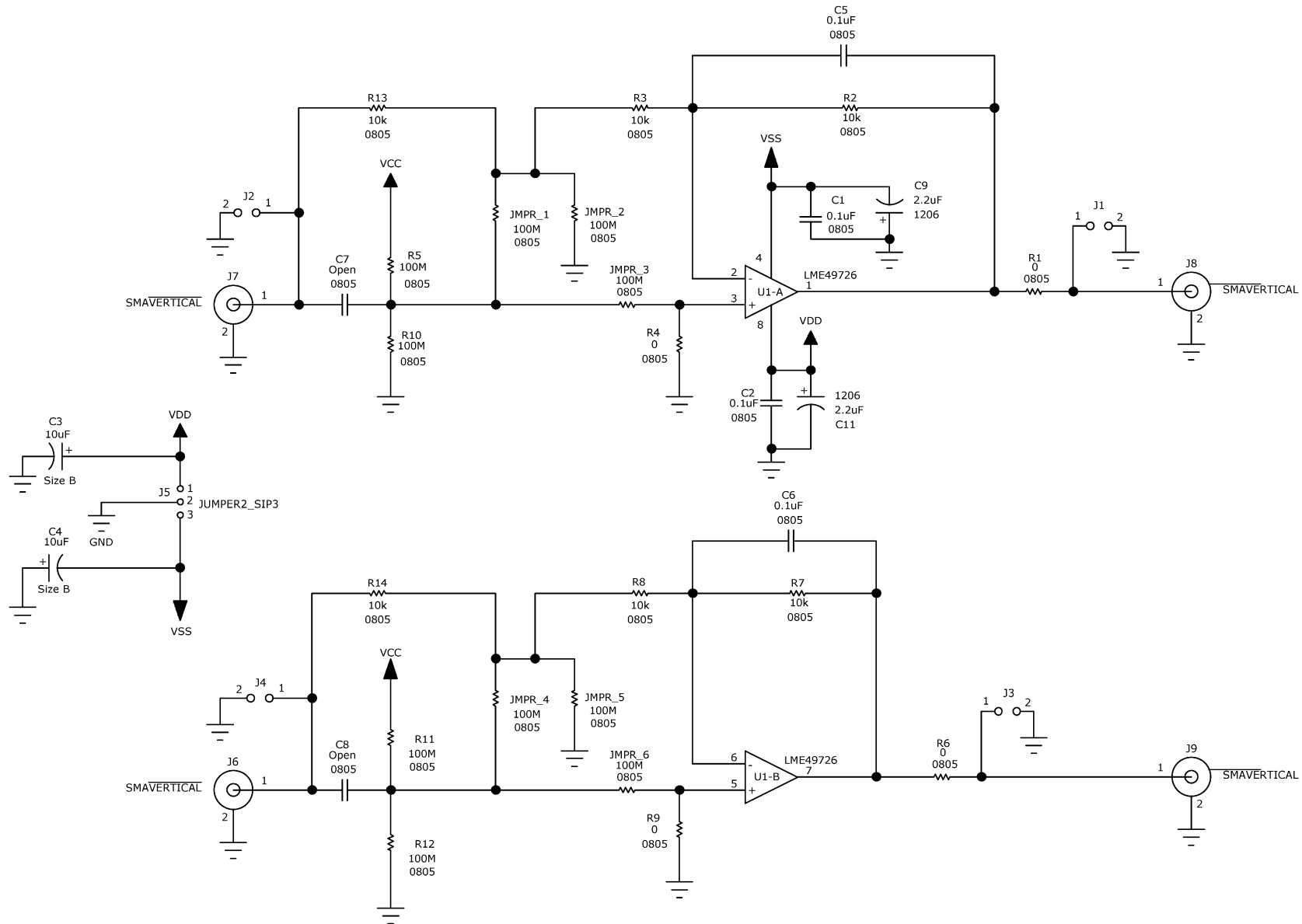

LME49726 Demo Board Views

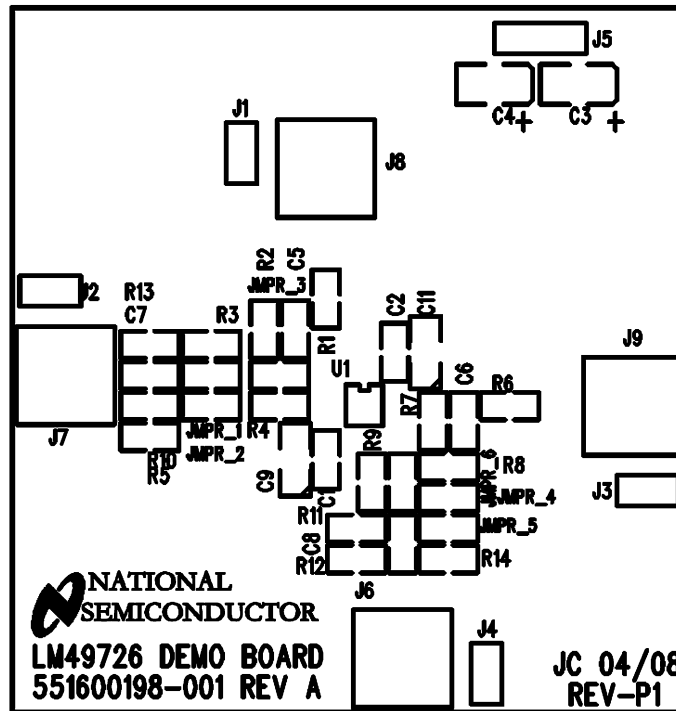

Figure 49. Top Silkscreen

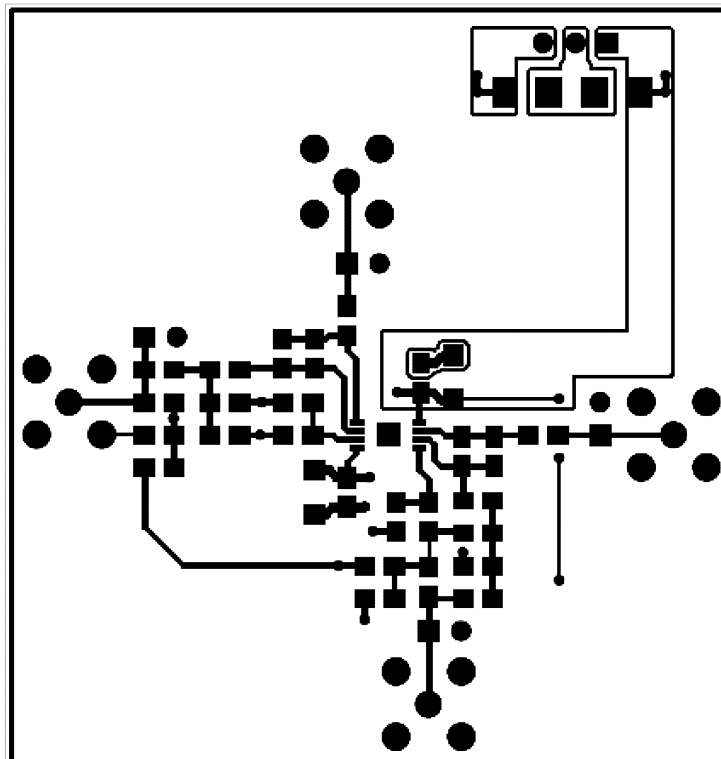

Figure 50. Top Layer

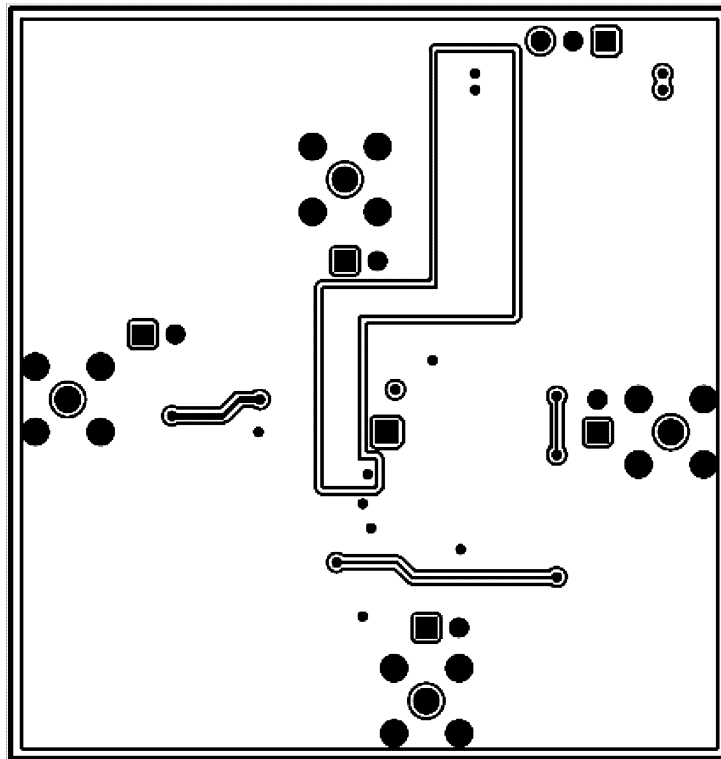

Figure 51. Bottom Layer

REVISION HISTORY

Rev	Date	Description
1.0	11/05/08	Initial release.
1.01	05/25/10	Increased Operating Temperature Range.
1.02	07/14/11	Added curves 30038602 and 03 and input text edits.
1.03	07/19/11	Re-released the D/S to the WEB after adding curves 30038602 and 03 .
C	04/04/13	Changed layout of National Data Sheet to TI format.

PACKAGING INFORMATION

Orderable Device	Status (1)	Package Type	Package Drawing	Pins	Package Qty	Eco Plan (2)	Lead finish/ Ball material (6)	MSL Peak Temp (3)	Op Temp (°C)	Device Marking (4/5)	Samples
LME49726MY/NOPB	ACTIVE	HVSSOP	DGN	8	1000	RoHS & Green	SN	Level-1-260C-UNLIM	-40 to 85	ZA3	Samples
LME49726MYX/NOPB	ACTIVE	HVSSOP	DGN	8	3500	RoHS & Green	SN	Level-1-260C-UNLIM	-40 to 85	ZA3	Samples

(1) The marketing status values are defined as follows:

ACTIVE: Product device recommended for new designs.

LIFEBUY: TI has announced that the device will be discontinued, and a lifetime-buy period is in effect.

NRND: Not recommended for new designs. Device is in production to support existing customers, but TI does not recommend using this part in a new design.

PREVIEW: Device has been announced but is not in production. Samples may or may not be available.

OBSOLETE: TI has discontinued the production of the device.

(2) **RoHS:** TI defines "RoHS" to mean semiconductor products that are compliant with the current EU RoHS requirements for all 10 RoHS substances, including the requirement that RoHS substance do not exceed 0.1% by weight in homogeneous materials. Where designed to be soldered at high temperatures, "RoHS" products are suitable for use in specified lead-free processes. TI may reference these types of products as "Pb-Free".

RoHS Exempt: TI defines "RoHS Exempt" to mean products that contain lead but are compliant with EU RoHS pursuant to a specific EU RoHS exemption.

Green: TI defines "Green" to mean the content of Chlorine (Cl) and Bromine (Br) based flame retardants meet JS709B low halogen requirements of <=1000ppm threshold. Antimony trioxide based flame retardants must also meet the <=1000ppm threshold requirement.

(3) MSL, Peak Temp. - The Moisture Sensitivity Level rating according to the JEDEC industry standard classifications, and peak solder temperature.

(4) There may be additional marking, which relates to the logo, the lot trace code information, or the environmental category on the device.

(5) Multiple Device Markings will be inside parentheses. Only one Device Marking contained in parentheses and separated by a "~" will appear on a device. If a line is indented then it is a continuation of the previous line and the two combined represent the entire Device Marking for that device.

(6) Lead finish/Ball material - Orderable Devices may have multiple material finish options. Finish options are separated by a vertical ruled line. Lead finish/Ball material values may wrap to two lines if the finish value exceeds the maximum column width.

Important Information and Disclaimer:The information provided on this page represents TI's knowledge and belief as of the date that it is provided. TI bases its knowledge and belief on information provided by third parties, and makes no representation or warranty as to the accuracy of such information. Efforts are underway to better integrate information from third parties. TI has taken and continues to take reasonable steps to provide representative and accurate information but may not have conducted destructive testing or chemical analysis on incoming materials and chemicals. TI and TI suppliers consider certain information to be proprietary, and thus CAS numbers and other limited information may not be available for release.

In no event shall TI's liability arising out of such information exceed the total purchase price of the TI part(s) at issue in this document sold by TI to Customer on an annual basis.

TAPE AND REEL INFORMATION

QUADRANT ASSIGNMENTS FOR PIN 1 ORIENTATION IN TAPE



*All dimensions are nominal

Device	Package Type	Package Drawing	Pins	SPQ	Reel Diameter (mm)	Reel Width W1 (mm)	A0 (mm)	B0 (mm)	K0 (mm)	P1 (mm)	W (mm)	Pin1 Quadrant
LME49726MY/NOPB	HVSSOP	DGN	8	1000	178.0	12.4	5.3	3.4	1.4	8.0	12.0	Q1
LME49726MYX/NOPB	HVSSOP	DGN	8	3500	330.0	12.4	5.3	3.4	1.4	8.0	12.0	Q1

TAPE AND REEL BOX DIMENSIONS

*All dimensions are nominal

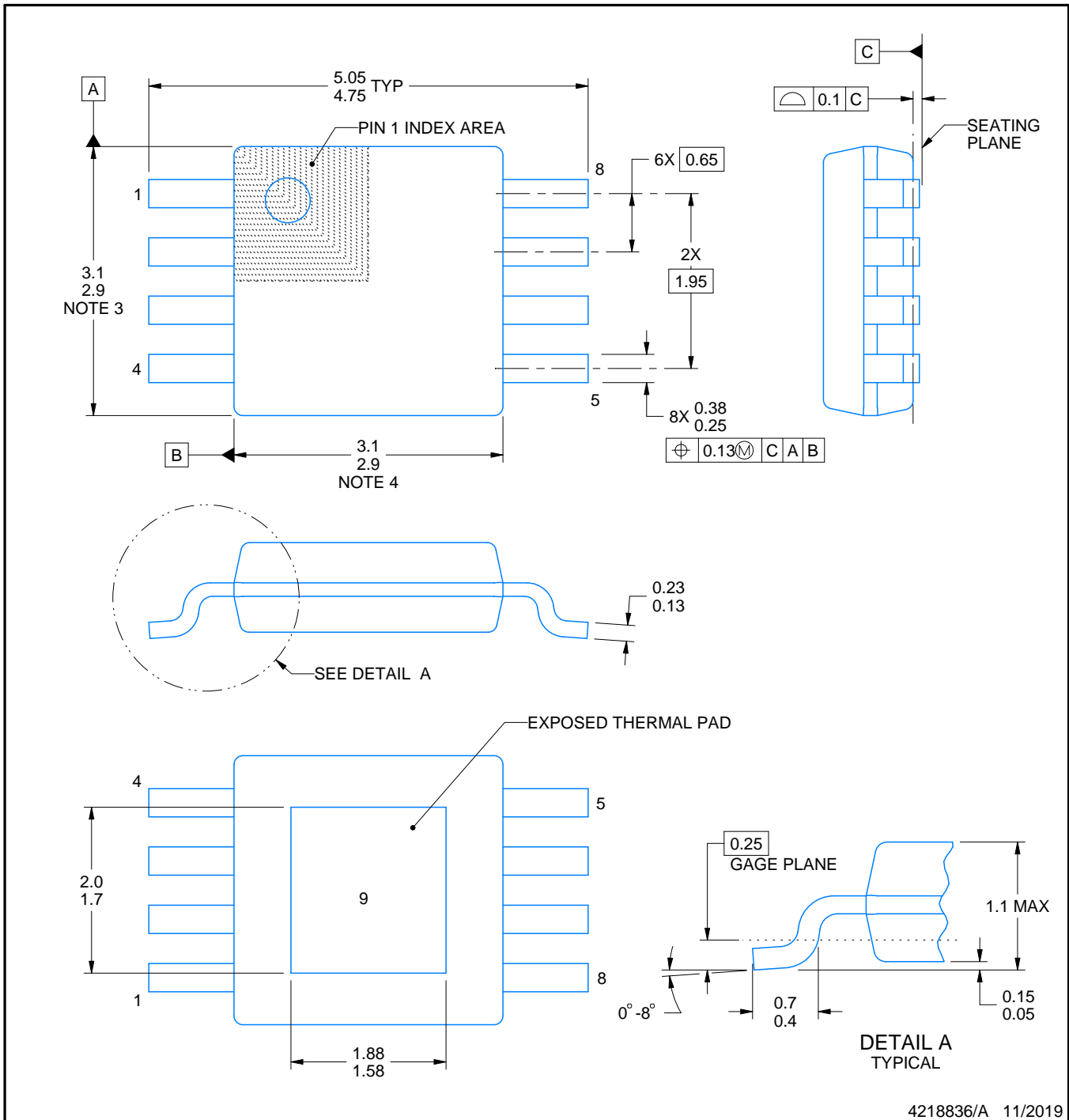
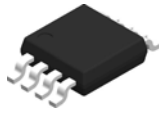
Device	Package Type	Package Drawing	Pins	SPQ	Length (mm)	Width (mm)	Height (mm)
LME49726MY/NOPB	HVSSOP	DGN	8	1000	208.0	191.0	35.0
LME49726MYX/NOPB	HVSSOP	DGN	8	3500	367.0	367.0	35.0



4218836/A 11/2019

NOTES:

PowerPAD is a trademark of Texas Instruments.

1. All linear dimensions are in millimeters. Any dimensions in parenthesis are for reference only. Dimensioning and tolerancing per ASME Y14.5M.
2. This drawing is subject to change without notice.
3. This dimension does not include mold flash, protrusions, or gate burrs. Mold flash, protrusions, or gate burrs shall not exceed 0.15 mm per side.
4. This dimension does not include interlead flash. Interlead flash shall not exceed 0.25 mm per side.
5. Reference JEDEC registration MO-187.

EXAMPLE BOARD LAYOUT

DGN0008A

PowerPAD™ VSSOP - 1.1 mm max height

SMALL OUTLINE PACKAGE

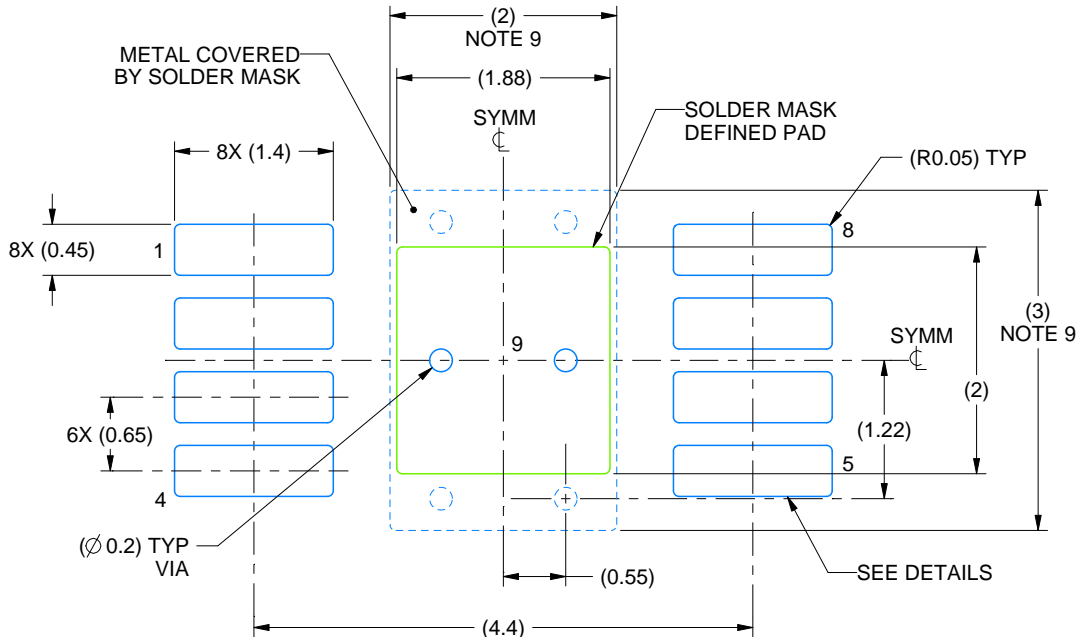

LAND PATTERN EXAMPLE
EXPOSED METAL SHOWN
SCALE: 15X

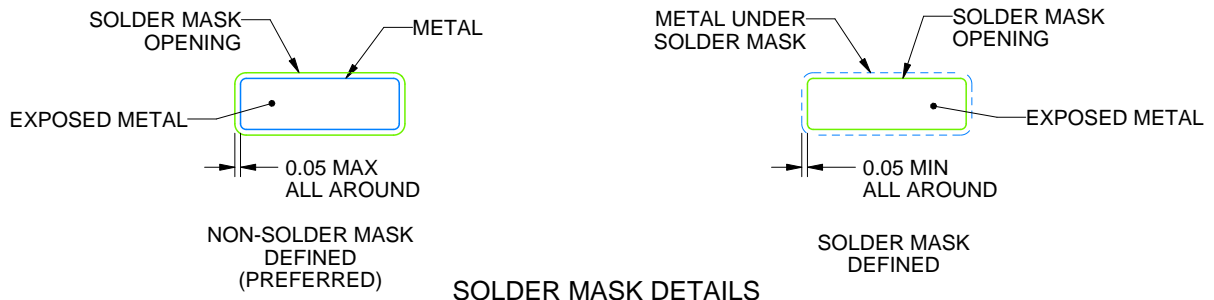

4218836/A 11/2019

NOTES: (continued)

6. Publication IPC-7351 may have alternate designs.
7. Solder mask tolerances between and around signal pads can vary based on board fabrication site.
8. Vias are optional depending on application, refer to device data sheet. If any vias are implemented, refer to their locations shown on this view. It is recommended that vias under paste be filled, plugged or tented.
9. Size of metal pad may vary due to creepage requirement.

EXAMPLE STENCIL DESIGN

DGN0008A

PowerPAD™ VSSOP - 1.1 mm max height

SMALL OUTLINE PACKAGE

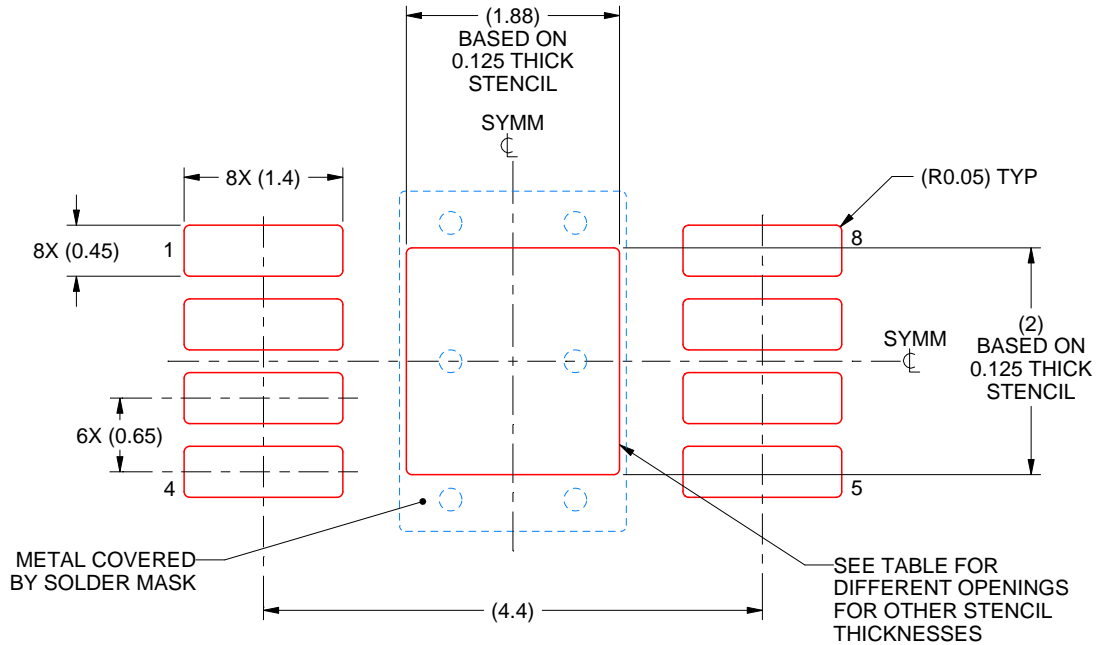

SOLDER PASTE EXAMPLE
EXPOSED PAD 9:
100% PRINTED SOLDER COVERAGE BY AREA
SCALE: 15X

STENCIL THICKNESS	SOLDER STENCIL OPENING
0.1	2.10 X 2.24
0.125	1.88 X 2.00 (SHOWN)
0.15	1.72 X 1.83
0.175	1.59 X 1.69

4218836/A 11/2019

NOTES: (continued)

10. Laser cutting apertures with trapezoidal walls and rounded corners may offer better paste release. IPC-7525 may have alternate design recommendations.
11. Board assembly site may have different recommendations for stencil design.

IMPORTANT NOTICE AND DISCLAIMER

TI PROVIDES TECHNICAL AND RELIABILITY DATA (INCLUDING DATA SHEETS), DESIGN RESOURCES (INCLUDING REFERENCE DESIGNS), APPLICATION OR OTHER DESIGN ADVICE, WEB TOOLS, SAFETY INFORMATION, AND OTHER RESOURCES "AS IS" AND WITH ALL FAULTS, AND DISCLAIMS ALL WARRANTIES, EXPRESS AND IMPLIED, INCLUDING WITHOUT LIMITATION ANY IMPLIED WARRANTIES OF MERCHANTABILITY, FITNESS FOR A PARTICULAR PURPOSE OR NON-INFRINGEMENT OF THIRD PARTY INTELLECTUAL PROPERTY RIGHTS.

These resources are intended for skilled developers designing with TI products. You are solely responsible for (1) selecting the appropriate TI products for your application, (2) designing, validating and testing your application, and (3) ensuring your application meets applicable standards, and any other safety, security, regulatory or other requirements.

These resources are subject to change without notice. TI grants you permission to use these resources only for development of an application that uses the TI products described in the resource. Other reproduction and display of these resources is prohibited. No license is granted to any other TI intellectual property right or to any third party intellectual property right. TI disclaims responsibility for, and you will fully indemnify TI and its representatives against, any claims, damages, costs, losses, and liabilities arising out of your use of these resources.

TI's products are provided subject to [TI's Terms of Sale](#) or other applicable terms available either on ti.com or provided in conjunction with such TI products. TI's provision of these resources does not expand or otherwise alter TI's applicable warranties or warranty disclaimers for TI products.

TI objects to and rejects any additional or different terms you may have proposed.

Mailing Address: Texas Instruments, Post Office Box 655303, Dallas, Texas 75265
Copyright © 2021, Texas Instruments Incorporated

Looking for pricing, stock, or lifecycle information?

Click below to explore more details on WIN SOURCE:

 [View LME49726MY/NOPB on WIN SOURCE](#)

 [Texas Instruments](#) Information

Optimize Your Supply Chain with WIN SOURCE Solutions

-  Global Sourcing Solution
-  Obsolete Management
-  Cost Control Management
-  Shortage Management
-  Alternative Solution
-  Excess Inventory Management