



# THE DATASHEET OF LMH6551MAX/NOPB



## LMH6551 Differential, High-Speed Op Amp

### 1 Features

- 370 MHz –3-dB Bandwidth ( $V_{OUT} = 0.5 V_{PP}$ )
- 50 MHz 0.1-dB Bandwidth
- 2400 V/ $\mu$ s Slew Rate
- 18 ns Settling Time to 0.05%
- –94/–96 dB HD2/HD3 at 5 MHz

### 2 Applications

- Differential AD Driver
- Video Over Twisted-Pair
- Differential Line Driver
- Single End to Differential Converter
- High-Speed Differential Signaling
- IF/RF Amplifier
- SAW Filter Buffer/Driver

### 3 Description

The LMH6551 device is a high-performance voltage feedback differential amplifier and is part of the LMH™ integrated circuits family of devices. The LMH6551 has the high speed and low distortion necessary for driving high-performance ADCs as well as the current handling capability to drive signals over balanced transmission lines like CAT 5 data cables. The LMH6551 can handle a wide range of video and data formats.

With external gain set resistors, the LMH6551 can be used at any desired gain. Gain flexibility coupled with high speed makes the LMH6551 suitable for use as an IF amplifier in high-performance communications equipment.

The LMH6551 is available in the space-saving SOIC and VSSOP packages.

#### Device Information<sup>(1)</sup>

PART NUMBER	PACKAGE	BODY SIZE (NOM)
LMH6551	SOIC (8)	4.90 mm x 3.91 mm
	VSSOP (8)	3.00 mm x 3.00 mm

(1) For all available packages, see the orderable addendum at the end of the datasheet.

### 4 Typical Application

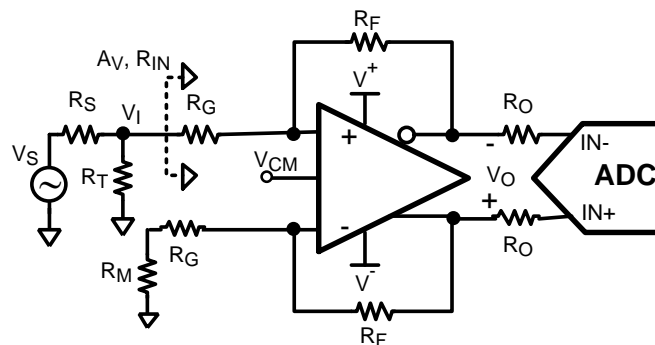

For  $R_M \ll R_G$  :

$$A_v = \frac{V_O}{V_I} \cong \frac{R_F}{R_G}$$

$$R_{IN} \cong \frac{2R_G(1 + A_v)}{2 + A_v}$$

DesignTarget:

- 1) Set  $R_T = \frac{1}{\frac{1}{R_S} - \frac{1}{R_{IN}}}$
- 2) Set  $R_M = R_T \parallel R_S$



## Table of Contents

<b>1 Features</b> .....	<b>1</b>	8.3 Feature Description .....	<b>13</b>
<b>2 Applications</b> .....	<b>1</b>	8.4 Device Functional Modes .....	<b>13</b>
<b>3 Description</b> .....	<b>1</b>	<b>9 Application and Implementation</b> .....	<b>14</b>
<b>4 Typical Application</b> .....	<b>1</b>	9.1 Application Information .....	<b>14</b>
<b>5 Revision History</b> .....	<b>2</b>	9.2 Typical Applications .....	<b>14</b>
<b>6 Pin Configuration and Functions</b> .....	<b>3</b>	<b>10 Power Supply Recommendations</b> .....	<b>21</b>
<b>7 Specifications</b> .....	<b>3</b>	<b>11 Layout</b> .....	<b>22</b>
7.1 Absolute Maximum Ratings .....	<b>3</b>	11.1 Layout Guidelines .....	<b>22</b>
7.2 ESD Ratings .....	<b>3</b>	11.2 Layout Example .....	<b>22</b>
7.3 Recommended Operating Conditions .....	<b>4</b>	11.3 Power Dissipation .....	<b>23</b>
7.4 Thermal Information .....	<b>4</b>	11.4 ESD Protection .....	<b>23</b>
7.5 Electrical Characteristics: $\pm 5$ V .....	<b>4</b>	<b>12 Device and Documentation Support</b> .....	<b>24</b>
7.6 Electrical Characteristics: 5 V <sup>(4)</sup> .....	<b>6</b>	12.1 Documentation Support .....	<b>24</b>
7.7 Electrical Characteristics: 3.3 V <sup>(4)</sup> .....	<b>7</b>	12.2 Trademarks .....	<b>24</b>
7.8 Typical Performance Characteristics .....	<b>9</b>	12.3 Electrostatic Discharge Caution .....	<b>24</b>
<b>8 Detailed Description</b> .....	<b>13</b>	12.4 Glossary .....	<b>24</b>
8.1 Overview .....	<b>13</b>	<b>13 Mechanical, Packaging, and Orderable Information</b> .....	<b>24</b>
8.2 Functional Block Diagram .....	<b>13</b>		

## 5 Revision History

NOTE: Page numbers for previous revisions may differ from page numbers in the current version.

<b>Changes from Revision C (March 2013) to Revision D</b>	<b>Page</b>
<ul style="list-style-type: none"> <li>Added <i>ESD Ratings</i> table, <i>Feature Description</i> section, <i>Device Functional Modes</i>, <i>Application and Implementation</i> section, <i>Power Supply Recommendations</i> section, <i>Layout</i> section, <i>Device and Documentation Support</i> section, and <i>Mechanical, Packaging, and Orderable Information</i> section .....</li> </ul>	<b>1</b>

<b>Changes from Revision B (March 2013) to Revision C</b>	<b>Page</b>
<ul style="list-style-type: none"> <li>Changed layout of National Data Sheet to TI format .....</li> </ul>	<b>22</b>

## 6 Pin Configuration and Functions

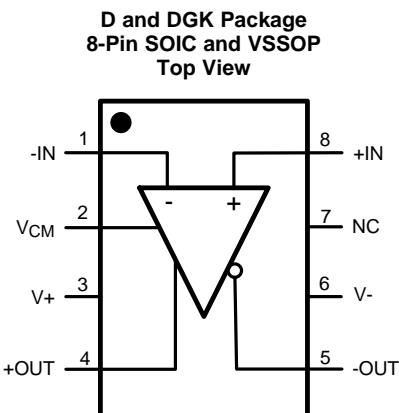

**Pin Functions**

PIN		I/O	DESCRIPTION
NAME	NO.		
-IN	1	I	Negative Input
VCM	2	I	Output Common-Mode Voltage
V+	3	P	Positive Supply
+OUT	4	O	Positive Output
-OUT	5	O	Negative Output
V-	6	P	Negative Supply
NC	7	—	No Connection
+IN	8	I	Positive Input

## 7 Specifications

### 7.1 Absolute Maximum Ratings <sup>(1)(2)(3)</sup>

	MIN	MAX	UNIT
Supply Voltage		13.2	V
Common-Mode Input Voltage		±Vs	V
Maximum Input Current (pins 1, 2, 7, 8)		30	mA
Maximum Output Current (pins 4, 5)		See <sup>(4)</sup>	
Maximum Junction Temperature		150	°C
Storage Temperature, T <sub>stg</sub>	-65	150	°C

- (1) *Absolute Maximum Ratings* indicate limits beyond which damage to the device may occur. *Recommended Operating Conditions* indicate conditions for which the device is intended to be functional, but specific performance is not ensured. For ensured specifications, see the Electrical Characteristics tables.
- (2) If Military/Aerospace specified devices are required, please contact the Texas Instruments Sales Office/ Distributors for availability and specifications.
- (3) For Soldering Information, see Product Folder at [www.ti.com](http://www.ti.com) and SNOA549.
- (4) The maximum output current (I<sub>OUT</sub>) is determined by device power dissipation limitations.

### 7.2 ESD Ratings

		VALUE	UNIT
V <sub>(ESD)</sub>	Electrostatic discharge	Human-body model (HBM), per ANSI/ESDA/JEDEC JS-001 <sup>(1)</sup>	±2000
		Machine model (MM)	±200

- (1) JEDEC document JEP155 states that 500-V HBM allows safe manufacturing with a standard ESD control process.

### 7.3 Recommended Operating Conditions

	MIN	NOM	MAX	UNIT
Operating Temperature Range	-40		+125	°C
Total Supply Voltage	3		12	V

### 7.4 Thermal Information

THERMAL METRIC <sup>(1)</sup>	LMH6551		UNIT
	D	DGK	
	8 PINS	8 PINS	
R <sub>θJA</sub> Junction-to-ambient thermal resistance <sup>(2)</sup>	150	235	°C/W

(1) For more information about traditional and new thermal metrics, see the *IC Package Thermal Metrics* application report, [SPRA953](#).

(2) The maximum power dissipation is a function of T<sub>J(MAX)</sub>, θ<sub>JA</sub> and T<sub>A</sub>. The maximum allowable power dissipation at any ambient temperature is P<sub>D</sub> = (T<sub>J(MAX)</sub> – T<sub>A</sub>) / θ<sub>JA</sub>. All numbers apply for package soldered directly into a 2 layer PC board with zero air flow.

### 7.5 Electrical Characteristics: ±5 V<sup>(1)</sup>

Single-ended in differential out, T<sub>A</sub> = 25°C, G = +1, V<sub>S</sub> = ±5 V, V<sub>CM</sub> = 0 V, R<sub>F</sub> = R<sub>G</sub> = 365 Ω, R<sub>L</sub> = 500 Ω; unless specified.

PARAMETER		TEST CONDITIONS	MIN <sup>(2)</sup>	TYP <sup>(3)</sup>	MAX <sup>(2)</sup>	UNIT
<b>AC PERFORMANCE (DIFFERENTIAL)</b>						
SSBW	Small Signal -3 dB Bandwidth	V <sub>OUT</sub> = 0.5 V <sub>PP</sub>		370		MHz
LSBW	Large Signal -3 dB Bandwidth	V <sub>OUT</sub> = 2 V <sub>PP</sub>		340		MHz
		V <sub>OUT</sub> = 4 V <sub>PP</sub>		320		MHz
	0.1 dB Bandwidth	V <sub>OUT</sub> = 2 V <sub>PP</sub>		50		MHz
	Slew Rate	4-V Step <sup>(4)</sup>		2400		V/μs
	Rise/Fall Time	2-V Step		1.8		ns
	Settling Time	2-V Step, 0.05%		18		ns
<b>V<sub>CM</sub> PIN AC PERFORMANCE (COMMON-MODE FEEDBACK AMPLIFIER)</b>						
	Common-Mode Small Signal Bandwidth	V <sub>CM</sub> bypass capacitor removed		200		MHz
<b>DISTORTION AND NOISE RESPONSE</b>						
HD2		V <sub>O</sub> = 2 V <sub>PP</sub> , f = 5 MHz, R <sub>L</sub> = 800 Ω		-94		dBc
HD2		V <sub>O</sub> = 2 V <sub>PP</sub> , f = 20MHz, R <sub>L</sub> = 800 Ω		-85		dBc
HD3		V <sub>O</sub> = 2 V <sub>PP</sub> , f = 5 MHz, R <sub>L</sub> = 800 Ω		-96		dBc
HD3		V <sub>O</sub> = 2 V <sub>PP</sub> , f = 20 MHz, R <sub>L</sub> = 800 Ω		-72		dBc
e <sub>n</sub>	Input Referred Voltage Noise	Freq ≥ 1 MHz		6.0		nV/√Hz
i <sub>n</sub>	Input Referred Noise Current	Freq ≥ 1 MHz		1.5		pA/√Hz
<b>INPUT CHARACTERISTICS (DIFFERENTIAL)</b>						
V <sub>OSD</sub>	Input Offset Voltage	Differential Mode, V <sub>ID</sub> = 0, V <sub>CM</sub> = 0		0.5	±4	mV
			At extreme temperatures			
	Input Offset Voltage Average Temperature Drift <sup>(5)</sup>			-0.8		μV/°C
I <sub>BI</sub>	Input Bias Current <sup>(6)</sup>			-4	0	μA
					-10	
	Input Bias Current Average Temperature Drift <sup>(5)</sup>			-2.6		nA/°C

(1) Electrical Table values apply only for factory testing conditions at the temperature indicated. Factory testing conditions result in very limited self-heating of the device such that T<sub>J</sub> = T<sub>A</sub>. No specification of parametric performance is indicated in the electrical tables under conditions of internal self-heating where T<sub>J</sub> > T<sub>A</sub>.

(2) Limits are 100% production tested at 25°C. Limits over the operating temperature range are specified through correlation using Statistical Quality Control (SQC) methods.

(3) Typical numbers are the most likely parametric norm.

(4) Slew Rate is the average of the rising and falling edges.

(5) Drift determined by dividing the change in parameter at temperature extremes by the total temperature change.

(6) Negative input current implies current flowing out of the device.

**Electrical Characteristics:  $\pm 5$  V<sup>(1)</sup> (continued)**

Single-ended in differential out,  $T_A = 25^\circ\text{C}$ ,  $G = +1$ ,  $V_S = \pm 5$  V,  $V_{CM} = 0$  V,  $R_F = R_G = 365 \Omega$ ,  $R_L = 500 \Omega$ ; unless specified.

PARAMETER		TEST CONDITIONS	MIN <sup>(2)</sup>	TYP <sup>(3)</sup>	MAX <sup>(2)</sup>	UNIT
Input Bias Difference		Difference in Bias currents between the two inputs	0.03			$\mu\text{A}$
CMRR	Common-Mode Rejection Ratio	DC, $V_{CM} = 0$ V, $V_{ID} = 0$ V	72	80		dBc
$R_{IN}$	Input Resistance	Differential	5			M $\Omega$
$C_{IN}$	Input Capacitance	Differential	1			pF
CMVR	Input Common-Mode Voltage Range	CMRR > 53dB	+3.1 -4.6	+3.2 -4.7		V
<b><math>V_{CM}</math> PIN INPUT CHARACTERISTICS (COMMON-MODE FEEDBACK AMPLIFIER)</b>						
$V_{OSC}$	Input Offset Voltage	Common Mode, $V_{ID} = 0$	0.5		$\pm 5$	mV
			At extreme temperatures		$\pm 8$	
Input Offset Voltage Average Temperature Drift <sup>(5)</sup>			8.2			$\mu\text{V}/^\circ\text{C}$
Input Bias Current <sup>(6)</sup>			-2			$\mu\text{A}$
$V_{CM}$	CMRR	$V_{ID} = 0$ V, 1-V step on $V_{CM}$ pin, measure $V_{OD}$	70	75		dB
Input Resistance			25			k $\Omega$
Common-Mode Gain		$\Delta V_{O,CM}/\Delta V_{CM}$	0.995	0.999	1.005	V/V
<b>OUTPUT PERFORMANCE</b>						
Output Voltage Swing	Single-Ended, Peak to Peak		$\pm 7.38$	$\pm 7.8$		V
			At extreme temperatures	$\pm 7.18$		
Output Common-Mode Voltage Range		$V_{ID} = 0$ V,	$\pm 3.69$	$\pm 3.8$		V
$I_{OUT}$	Linear Output Current	$V_{OUT} = 0$ V	$\pm 50$	$\pm 65$		mA
$I_{SC}$	Short Circuit Current	Output Shorted to Ground $V_{IN} = 3$ -V Single-Ended <sup>(7)</sup>	140			mA
Output Balance Error		$\Delta V_{OUT}$ Common Mode / $\Delta V_{OUT}$ Differential, $V_{OUT} = 0.5$ Vpp Differential, $f = 10$ MHz	-70			dB
<b>MISCELLANEOUS PERFORMANCE</b>						
$A_{VOL}$	Open Loop Gain	Differential	70			dB
PSRR	Power Supply Rejection Ratio	DC, $\Delta V_S = \pm 1$ V	74	90		dB
Supply Current		$R_L = \infty$	11	12.5	14.5	mA
			At extreme temperatures		16.5	

(7) The maximum output current ( $I_{OUT}$ ) is determined by device power dissipation limitations.

## 7.6 Electrical Characteristics: 5 V<sup>(1)</sup>

Single-ended in differential out,  $T_A = 25^\circ\text{C}$ ,  $G = +1$ ,  $V_S = 5\text{ V}$ ,  $V_{CM} = 2.5\text{ V}$ ,  $R_F = R_G = 365\ \Omega$ ,  $R_L = 500\ \Omega$ ; unless specified.

PARAMETER		TEST CONDITIONS	MIN <sup>(2)</sup>	TYP <sup>(3)</sup>	MAX <sup>(2)</sup>	UNIT
SSBW	Small Signal -3 dB Bandwidth	$R_L = 500\ \Omega$ , $V_{OUT} = 0.5\ V_{PP}$		350		MHz
LSBW	Large Signal -3 dB Bandwidth	$R_L = 500\ \Omega$ , $V_{OUT} = 2\ V_{PP}$		300		MHz
	0.1 dB Bandwidth	$V_{OUT} = 2\ V_{PP}$		50		MHz
	Slew Rate	4-V Step <sup>(4)</sup>		1800		V/ $\mu\text{s}$
	Rise/Fall Time, 10% to 90%	4-V Step		2		ns
	Settling Time	4-V Step, 0.05%		17		ns
<b><math>V_{CM}</math> PIN AC PERFORMANCE (COMMON-MODE FEEDBACK AMPLIFIER)</b>						
	Common-Mode Small Signal Bandwidth			170		MHz
<b>DISTORTION AND NOISE RESPONSE</b>						
HD2	2 <sup>nd</sup> Harmonic Distortion	$V_O = 2\ V_{PP}$ , $f = 5\text{ MHz}$ , $R_L = 800\ \Omega$		-84		dBc
HD2		$V_O = 2\ V_{PP}$ , $f = 20\text{ MHz}$ , $R_L = 800\ \Omega$		-69		dBc
HD3	3 <sup>rd</sup> Harmonic Distortion	$V_O = 2\ V_{PP}$ , $f = 5\text{ MHz}$ , $R_L = 800\ \Omega$		-93		dBc
HD3		$V_O = 2\ V_{PP}$ , $f = 20\text{ MHz}$ , $R_L = 800\ \Omega$		-67		dBc
$e_n$	Input Referred Noise Voltage	Freq $\geq 1\text{ MHz}$		6.0		nV/ $\sqrt{\text{Hz}}$
$i_n$	Input Referred Noise Current	Freq $\geq 1\text{ MHz}$		1.5		pA/ $\sqrt{\text{Hz}}$
<b>INPUT CHARACTERISTICS (DIFFERENTIAL)</b>						
$V_{OSD}$	Input Offset Voltage	Differential Mode, $V_{ID} = 0$ , $V_{CM} = 0$		0.5	$\pm 4$	mV
			At extreme temperatures			
	Input Offset Voltage Average Temperature Drift <sup>(5)</sup>			-0.8		$\mu\text{V}/^\circ\text{C}$
$I_{BIAS}$	Input Bias Current <sup>(6)</sup>			-4	0	$\mu\text{A}$
	Input Bias Current Average Temperature Drift <sup>(5)</sup>			-3		nA/ $^\circ\text{C}$
	Input Bias Current Difference	Difference in Bias currents between the two inputs		0.03		$\mu\text{A}$
CMRR	Common-Mode Rejection Ratio	DC, $V_{ID} = 0\text{ V}$	70	78		dBc
	Input Resistance	Differential		5		M $\Omega$
	Input Capacitance	Differential		1		pF
$V_{ICM}$	Input Common-Mode Range	CMRR $> 53\text{ dB}$	+3.1 +0.4	+3.2 +0.3		
<b><math>V_{CM}</math> PIN INPUT CHARACTERISTICS (COMMON-MODE FEEDBACK AMPLIFIER)</b>						
	Input Offset Voltage	Common Mode, $V_{ID} = 0$		0.5	$\pm 5$	mV
			At extreme temperatures			
	Input Offset Voltage Average Temperature Drift			5.8		$\mu\text{V}/^\circ\text{C}$
	Input Bias Current			3		$\mu\text{A}$
$V_{CM}$	CMRR	$V_{ID} = 0$ , 1V step on $V_{CM}$ pin, measure $V_{OD}$	70	75		dB
	Input Resistance	$V_{CM}$ pin to ground		25		k $\Omega$

- (1) Electrical Table values apply only for factory testing conditions at the temperature indicated. Factory testing conditions result in very limited self-heating of the device such that  $T_J = T_A$ . No specification of parametric performance is indicated in the electrical tables under conditions of internal self-heating where  $T_J > T_A$ .
- (2) Limits are 100% production tested at  $25^\circ\text{C}$ . Limits over the operating temperature range are specified through correlation using Statistical Quality Control (SQC) methods.
- (3) Typical numbers are the most likely parametric norm.
- (4) Slew Rate is the average of the rising and falling edges.
- (5) Drift determined by dividing the change in parameter at temperature extremes by the total temperature change.
- (6) Negative input current implies current flowing out of the device.

## Electrical Characteristics: 5 V<sup>(1)</sup> (continued)

Single-ended in differential out,  $T_A = 25^\circ\text{C}$ ,  $G = +1$ ,  $V_S = 5\text{ V}$ ,  $V_{CM} = 2.5\text{ V}$ ,  $R_F = R_G = 365\ \Omega$ ,  $R_L = 500\ \Omega$ ; unless specified.

PARAMETER		TEST CONDITIONS	MIN <sup>(2)</sup>	TYP <sup>(3)</sup>	MAX <sup>(2)</sup>	UNIT	
Common-Mode Gain		$\Delta V_{O,CM}/\Delta V_{CM}$	0.995	0.991	1.005	V/V	
<b>OUTPUT PERFORMANCE</b>							
$V_{OUT}$	Output Voltage Swing	Single-Ended, Peak to Peak, $V_S = \pm 2.5\text{ V}$ , $V_{CM} = 0\text{ V}$	$\pm 2.4$	$\pm 2.8$		V	
$I_{OUT}$	Linear Output Current	$V_{OUT} = 0\text{-V Differential}$	$\pm 45$	$\pm 60$		mA	
$I_{SC}$	Output Short Circuit Current	Output Shorted to Ground $V_{IN} = 3\text{-V Single-Ended}^{(7)}$		230		mA	
CMVR	Output Common-Mode Voltage Range	$V_{ID} = 0$ , $V_{CMpin} = 1.2\text{ V and } 3.8\text{ V}$	3.72	3.8		V	
			1.23	1.2			
Output Balance Error		$\Delta V_{OUT} \text{ Common Mode} / \Delta V_{OUT} \text{ Differential}$ , $V_{OUT} = 1\text{Vpp Differential}$ , $f = 10\text{ MHz}$		-65		dB	
<b>MISCELLANEOUS PERFORMANCE</b>							
Open Loop Gain		DC, Differential		70		dB	
PSRR	Power Supply Rejection Ratio	DC, $\Delta V_S = \pm 0.5\text{ V}$	72	88		dB	
$I_S$	Supply Current	$R_L = \infty$		10	11.5	13.5	mA
			At extreme temperatures			15.5	

(7) The maximum output current ( $I_{OUT}$ ) is determined by device power dissipation limitations.

## 7.7 Electrical Characteristics: 3.3 V<sup>(1)</sup>

Single-ended in differential out,  $T_A = 25^\circ\text{C}$ ,  $G = +1$ ,  $V_S = 3.3\text{ V}$ ,  $V_{CM} = 1.65\text{ V}$ ,  $R_F = R_G = 365\ \Omega$ ,  $R_L = 500\ \Omega$ ; unless specified.

PARAMETER		TEST CONDITIONS	MIN <sup>(2)</sup>	TYP <sup>(3)</sup>	MAX <sup>(2)</sup>	UNIT
SSBW	Small Signal -3 dB Bandwidth	$R_L = 500\ \Omega$ , $V_{OUT} = 0.5\text{ V}_{PP}$		320		MHz
LSBW	Large Signal -3 dB Bandwidth	$R_L = 500\ \Omega$ , $V_{OUT} = 1\text{ V}_{PP}$		300		MHz
Slew Rate		1-V Step <sup>(4)</sup>		700		V/ $\mu\text{s}$
Rise/Fall Time, 10% to 90%		1-V Step		2		ns
<b><math>V_{CM}</math> PIN AC PERFORMANCE (COMMON-MODE FEEDBACK AMPLIFIER)</b>						
Common-Mode Small Signal Bandwidth				95		MHz
<b>DISTORTION AND NOISE RESPONSE</b>						
HD2	2 <sup>nd</sup> Harmonic Distortion	$V_O = 1\text{ V}_{PP}$ , $f = 5\text{ MHz}$ , $R_L = 800\ \Omega$		-93		dBc
HD2		$V_O = 1\text{ V}_{PP}$ , $f = 20\text{ MHz}$ , $R_L = 800\ \Omega$		-74		dBc
HD3	3 <sup>rd</sup> Harmonic Distortion	$V_O = 1\text{ V}_{PP}$ , $f = 5\text{ MHz}$ , $R_L = 800\ \Omega$		-85		dBc
HD3		$V_O = 1\text{ V}_{PP}$ , $f = 20\text{ MHz}$ , $R_L = 800\ \Omega$		-69		dBc

- Electrical Table values apply only for factory testing conditions at the temperature indicated. Factory testing conditions result in very limited self-heating of the device such that  $T_J = T_A$ . No specification of parametric performance is indicated in the electrical tables under conditions of internal self-heating where  $T_J > T_A$ .
- Limits are 100% production tested at  $25^\circ\text{C}$ . Limits over the operating temperature range are specified through correlation using Statistical Quality Control (SQC) methods.
- Typical numbers are the most likely parametric norm.
- Slew Rate is the average of the rising and falling edges.

**Electrical Characteristics: 3.3 V<sup>(1)</sup> (continued)**

 Single-ended in differential out,  $T_A = 25^\circ\text{C}$ ,  $G = +1$ ,  $V_S = 3.3\text{ V}$ ,  $V_{CM} = 1.65\text{ V}$ ,  $R_F = R_G = 365\ \Omega$ ,  $R_L = 500\ \Omega$ ; unless specified.

PARAMETER		TEST CONDITIONS	MIN <sup>(2)</sup>	TYP <sup>(3)</sup>	MAX <sup>(2)</sup>	UNIT
<b>INPUT CHARACTERISTICS (DIFFERENTIAL)</b>						
$V_{OSD}$	Input Offset Voltage	Differential Mode, $V_{ID} = 0$ , $V_{CM} = 0$		1		mV
	Input Offset Voltage Average Temperature Drift <sup>(5)</sup>			1.6		$\mu\text{V}/^\circ\text{C}$
$I_{BIAS}$	Input Bias Current <sup>(6)</sup>			-8		$\mu\text{A}$
	Input Bias Current Average Temperature Drift <sup>(5)</sup>			9.5		$\text{nA}/^\circ\text{C}$
	Input Bias Current Difference	Difference in Bias currents between the two inputs		0.3		$\mu\text{A}$
CMRR	Common-Mode Rejection Ratio	DC, $V_{ID} = 0\text{ V}$		78		dBc
	Input Resistance	Differential		5		M $\Omega$
	Input Capacitance	Differential		1		pF
$V_{ICM}$	Input Common-Mode Range	CMRR > 53 dB		+1.5 +0.3		
<b><math>V_{CM}</math> PIN INPUT CHARACTERISTICS (COMMON-MODE FEEDBACK AMPLIFIER)</b>						
	Input Offset Voltage	Common Mode, $V_{ID} = 0$		1	$\pm 5$	mV
	Input Offset Voltage Average Temperature Drift			18.6		$\mu\text{V}/^\circ\text{C}$
	Input Bias Current			3		$\mu\text{A}$
	$V_{CM}$ CMRR	$V_{ID} = 0$ , 1-V step on $V_{CM}$ pin, measure $V_{OD}$		60		dB
	Input Resistance	$V_{CM}$ pin to ground		25		k $\Omega$
	Common-Mode Gain	$\Delta V_{O,CM}/\Delta V_{CM}$		0.999		V/V
<b>OUTPUT PERFORMANCE</b>						
$V_{OUT}$	Output Voltage Swing	Single-Ended, Peak to Peak, $V_S = 3.3\text{ V}$ , $V_{CM} = 1.65\text{ V}$	$\pm 0.75$	$\pm 0.9$		V
$I_{OUT}$	Linear Output Current	$V_{OUT} = 0\text{-V}$ Differential	$\pm 30$	$\pm 40$		mA
$I_{SC}$	Output Short Circuit Current	Output Shorted to Ground $V_{IN} = 2\text{-V}$ Single-Ended <sup>(7)</sup>		200		mA
CMVR	Output Common-Mode Voltage Range	$V_{ID} = 0$ , $V_{CMpin} = 1.2\text{ V}$ and $2.1\text{ V}$		2.1 1.2		V
	Output Balance Error	$\Delta V_{OUT}\text{-Common Mode} / \Delta V_{OUT}\text{Differential}$ , $V_{OUT} = 1\text{-V}_{pp}$ Differential, $f = 10\text{ MHz}$		-65		dB
<b>MISCELLANEOUS PERFORMANCE</b>						
	Open Loop Gain	DC, Differential		70		dB
PSRR	Power Supply Rejection Ratio	DC, $\Delta V_S = \pm 0.5\text{ V}$		75		dB
$I_S$	Supply Current	$R_L = \infty$		8		mA

(5) Drift determined by dividing the change in parameter at temperature extremes by the total temperature change.

(6) Negative input current implies current flowing out of the device.

 (7) The maximum output current ( $I_{OUT}$ ) is determined by device power dissipation limitations.

## 7.8 Typical Performance Characteristics

( $T_A = 25^\circ\text{C}$ ,  $V_S = \pm 5\text{ V}$ ,  $R_L = 500\ \Omega$ ,  $R_F = R_G = 365\ \Omega$ ; Unless Specified).

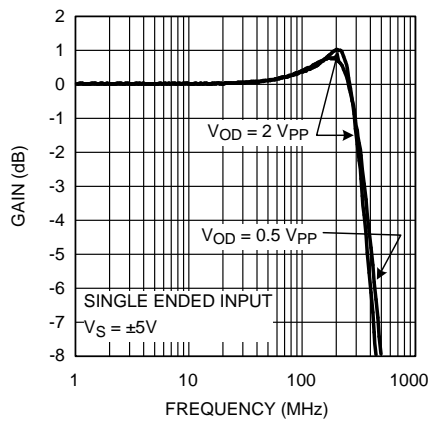

Figure 1. Frequency Response vs Supply Voltage

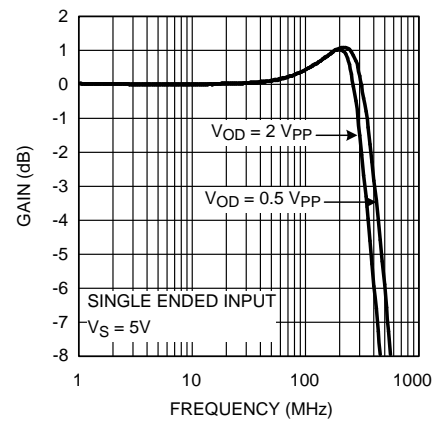

Figure 2. Frequency Response

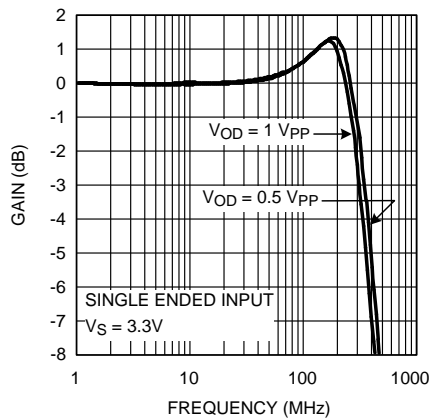

Figure 3. Frequency Response vs  $V_{OUT}$

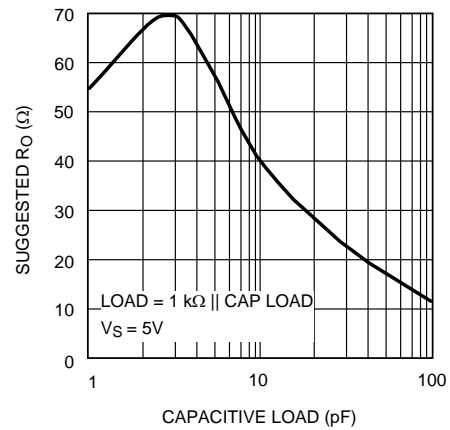

Figure 4. Suggested  $R_{OUT}$  vs Cap Load

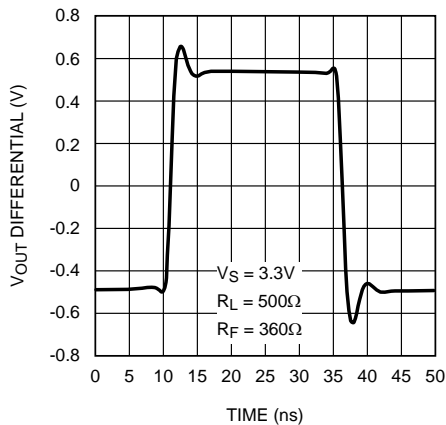

Figure 5. 1  $V_{PP}$  Pulse Response Single-Ended Input

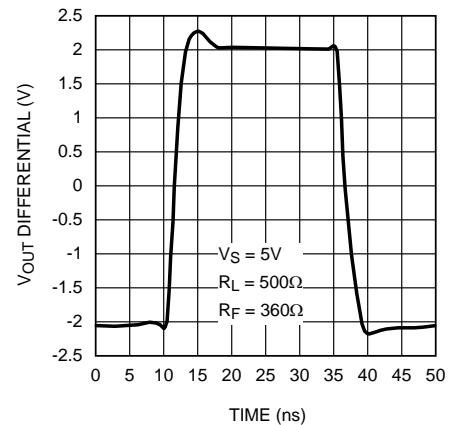

Figure 6. 2  $V_{PP}$  Pulse Response Single-Ended Input

Typical Performance Characteristics (continued)

( $T_A = 25^\circ\text{C}$ ,  $V_S = \pm 5\text{ V}$ ,  $R_L = 500\ \Omega$ ,  $R_F = R_G = 365\ \Omega$ ; Unless Specified).

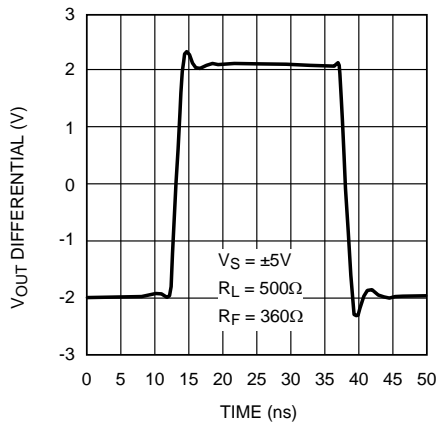

Figure 7. Large Signal Pulse Response

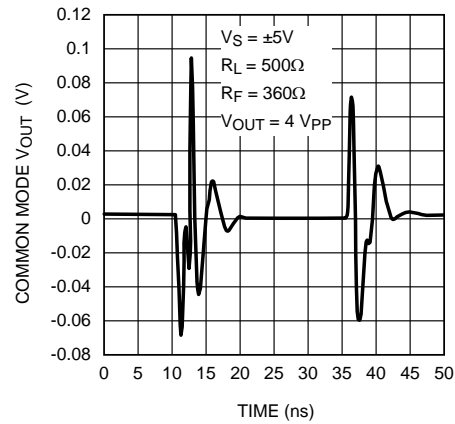

Figure 8. Output Common-Mode Pulse Response

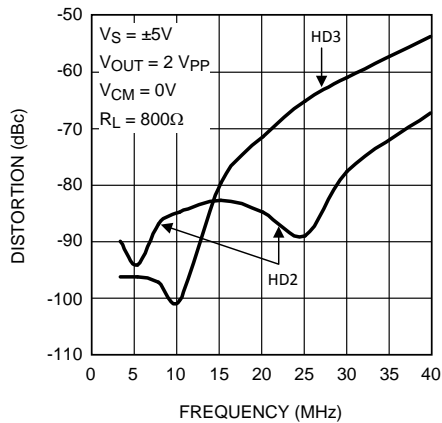

Figure 9. Distortion vs Frequency

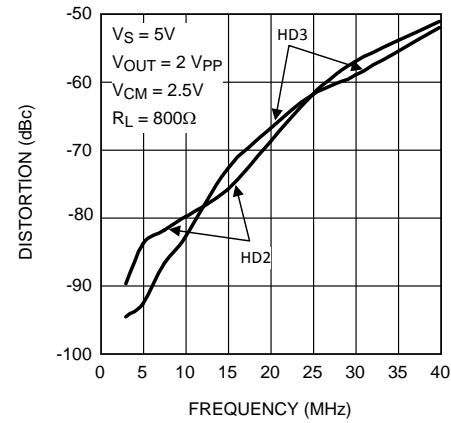

Figure 10. Distortion vs Frequency

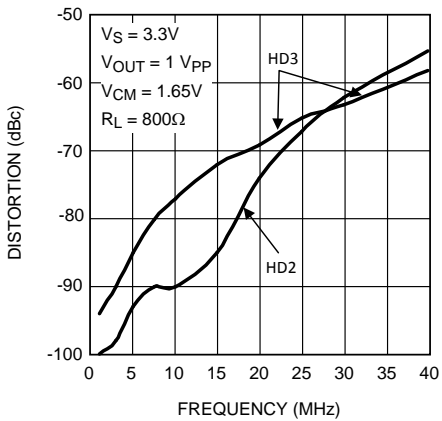

Figure 11. Distortion vs Frequency

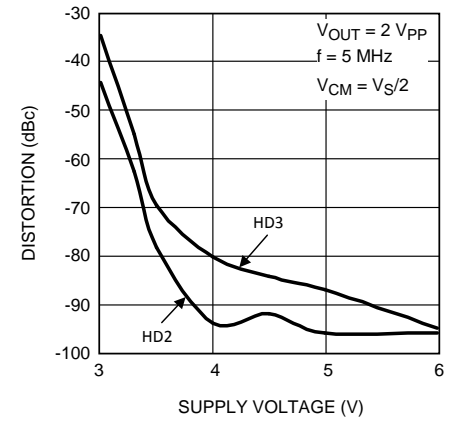

Figure 12. Distortion vs Supply Voltage (Split Supplies)

Typical Performance Characteristics (continued)

( $T_A = 25^\circ\text{C}$ ,  $V_S = \pm 5\text{ V}$ ,  $R_L = 500\ \Omega$ ,  $R_F = R_G = 365\ \Omega$ ; Unless Specified).

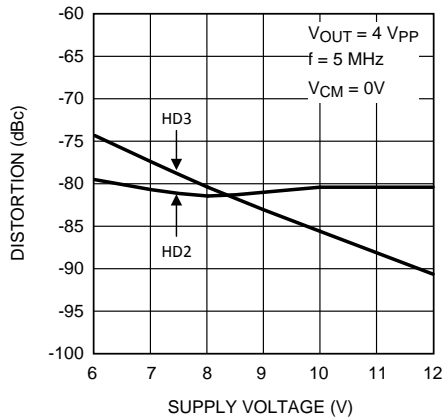

Figure 13. Distortion vs Supply Voltage (Single Supply)

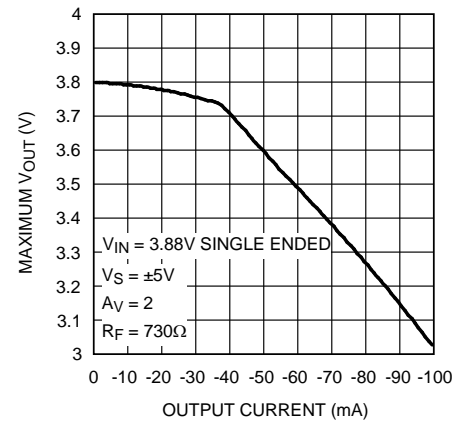

Figure 14. Maximum  $V_{OUT}$  vs  $I_{OUT}$

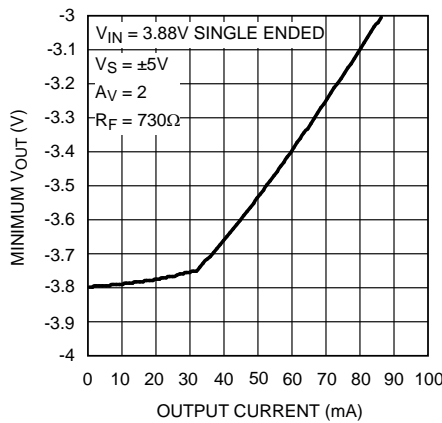

Figure 15. Minimum  $V_{OUT}$  vs  $I_{OUT}$

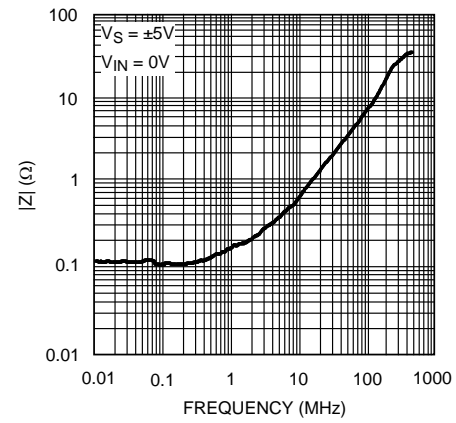

Figure 16. Closed-Loop Output Impedance

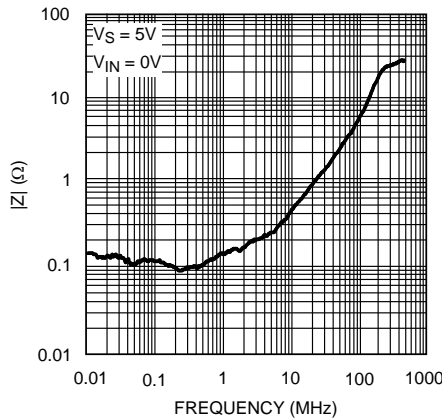

Figure 17. Closed-Loop Output Impedance

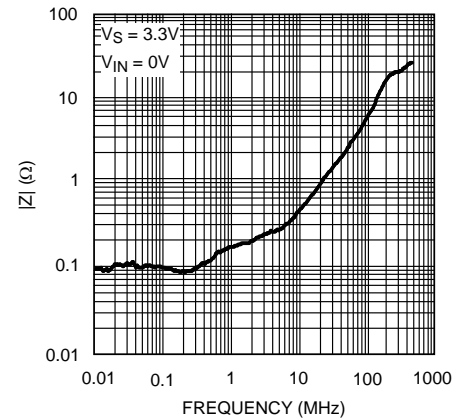

Figure 18. Closed-Loop Output Impedance

Typical Performance Characteristics (continued)

( $T_A = 25^\circ\text{C}$ ,  $V_S = \pm 5\text{ V}$ ,  $R_L = 500\ \Omega$ ,  $R_F = R_G = 365\ \Omega$ ; Unless Specified).

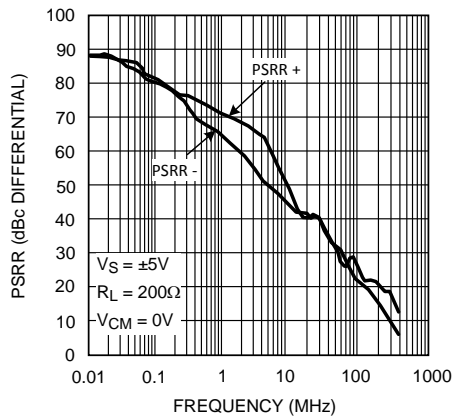

Figure 19. PSRR

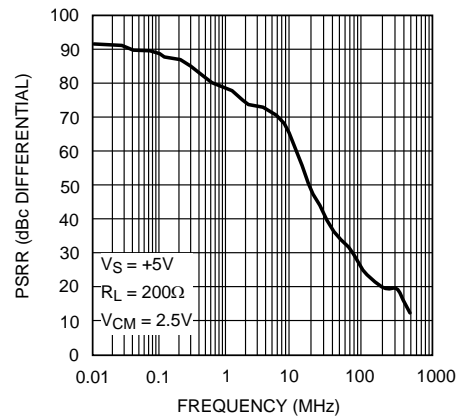

Figure 20. PSRR

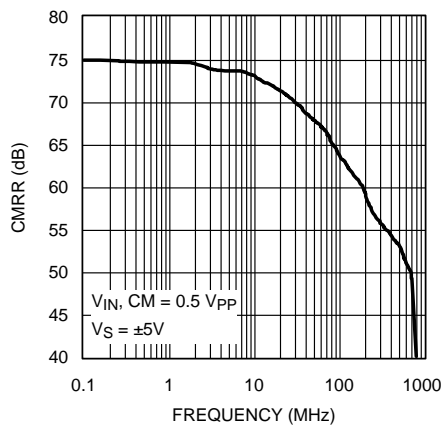

Figure 21. CMRR

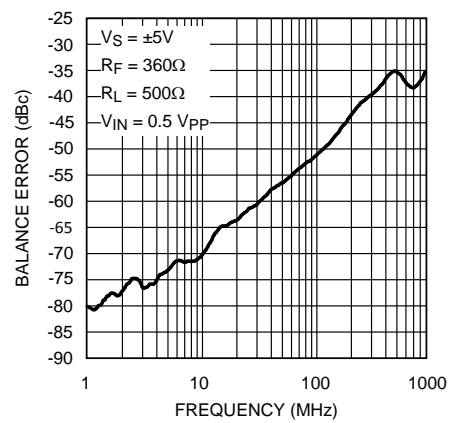

Figure 22. Balance Error

## 8 Detailed Description

### 8.1 Overview

The LMH6551 is a fully differential amplifier designed to provide low distortion amplification to wide bandwidth differential signals. The LMH6551, though fully integrated for ultimate balance and distortion performance, functionally provides three channels. Two of these channels are the  $V+$  and  $V-$  signal path channels, which function similarly to inverting mode operational amplifiers and are the primary signal paths. The third channel is the common-mode feedback circuit. This is the circuit that sets the output common mode as well as driving the  $V+$  and  $V-$  outputs to be equal magnitude and opposite phase, even when only one of the two input channels is driven. The common-mode feedback circuit allows single-ended to differential operation.

### 8.2 Functional Block Diagram

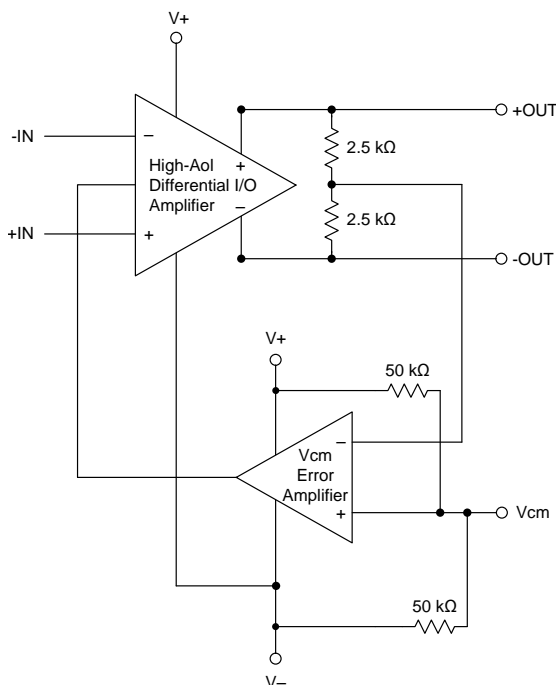

### 8.3 Feature Description

The LMH6551 combines a core differential I/O, high-gain block with an output common-mode sense that is compared to a reference voltage and then fed back into the main amplifier block to control the average output to that reference. The differential I/O block is a classic, high open-loop gain stage. The high-speed differential outputs include an internal averaging resistor network to sense the output common-mode voltage. This voltage is compared by a separate VCM error amplifier to the voltage on the VO<sub>CM</sub> pin. If floated, this reference is at half the total supply voltage across the device using two 50-k $\Omega$  resistors. This VCM error amplifier transmits a correction signal into the main amplifier to force the output average voltage to meet the target voltage on the VO<sub>CM</sub> pin.

### 8.4 Device Functional Modes

This wideband FDA requires external resistors for correct signal-path operation. When configured for the desired input impedance and gain setting with these external resistors, the amplifier can be either *on* with the PD pin asserted to a voltage greater than  $V_{S-} + 1.7$  V, or turned *off* by asserting PD low. Disabling the amplifier shuts off the quiescent current and stops correct amplifier operation. The signal path is still present for the source signal through the external resistors. The VO<sub>CM</sub> control pin sets the output average voltage. Left open, VO<sub>CM</sub> defaults to an internal midsupply value. Driving this high-impedance input with a voltage reference within its valid range sets a target for the internal VCM error amplifier.

## 9 Application and Implementation

### NOTE

Information in the following applications sections is not part of the TI component specification, and TI does not warrant its accuracy or completeness. TI's customers are responsible for determining suitability of components for their purposes. Customers should validate and test their design implementation to confirm system functionality.

### 9.1 Application Information

The LMH6551 is a fully differential amplifier designed to provide low distortion amplification to wide bandwidth differential signals. The LMH6551, though fully integrated for ultimate balance and distortion performance, functionally provides three channels. Two of these channels are the  $V^+$  and  $V^-$  signal path channels, which function similarly to inverting mode operational amplifiers and are the primary signal paths. The third channel is the common-mode feedback circuit. This is the circuit that sets the output common mode as well as driving the  $V^+$  and  $V^-$  outputs to be equal magnitude and opposite phase, even when only one of the two input channels is driven. The common-mode feedback circuit allows single-ended to differential operation.

The LMH6551 is a voltage feedback amplifier with gain set by external resistors. Output common-mode voltage is set by the  $V_{CM}$  pin. This pin should be driven by a low impedance reference and should be bypassed to ground with a 0.1  $\mu\text{F}$  ceramic capacitor. Any signal coupling into the  $V_{CM}$  will be passed along to the output and will reduce the dynamic range of the amplifier.

### 9.2 Typical Applications

#### 9.2.1 Typical Fully Differential Application

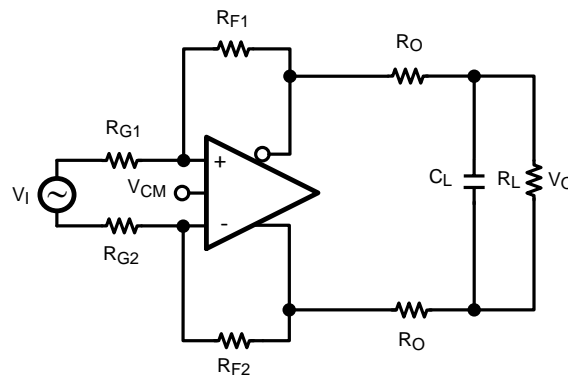

**Figure 23. Typical Fully Differential Application Schematic**

##### 9.2.1.1 Design Requirements

Applications using fully differential amplifiers have several requirements. The main requirements are high linearity and good signal amplitude. Linearity is accomplished by using well matched feedback and gain set resistors as well as an appropriate supply voltage. The signal amplitude can be tailored by using an appropriate gain. In this design, the gain is set for a gain of 2 ( $R_f=500/R_G=250$ ) and the distortion criteria is better than -90 dBc at a frequency of 5 MHz for HD2 and HD3. The supply voltage is set for  $\pm 5\text{ V}$  and the output common mode is 0 V.

##### 9.2.1.2 Detailed Design Procedure

###### 9.2.1.2.1 Fully Differential Operation

The LMH6551 will perform best when used with split supplies and in a fully differential configuration. See [Figure 23](#) and [Figure 24](#) for recommend circuits.

## Typical Applications (continued)

The circuit shown in Figure 23 is a typical fully differential application as might be used to drive an ADC. In this circuit closed loop gain,  $(A_V) = V_{OUT}/V_{IN} = R_F/R_G$ . For all the applications in this data sheet  $V_{IN}$  is presumed to be the voltage presented to the circuit by the signal source. For differential signals this will be the difference of the signals on each input (which will be double the magnitude of each individual signal), while in single-ended inputs it will just be the driven input signal.

The resistors  $R_O$  help keep the amplifier stable when presented with a load  $C_L$  as is typical in an analog to digital converter (ADC). When fed with a differential signal, the LMH6551 provides excellent distortion, balance and common-mode rejection provided the resistors  $R_F$ ,  $R_G$  and  $R_O$  are well matched and strict symmetry is observed in board layout. With a DC CMRR of over 80dB, the DC and low frequency CMRR of most circuits will be dominated by the external resistors and board trace resistance. At higher frequencies board layout symmetry becomes a factor as well. Precision resistors of at least 0.1% accuracy are recommended and careful board layout will also be required.

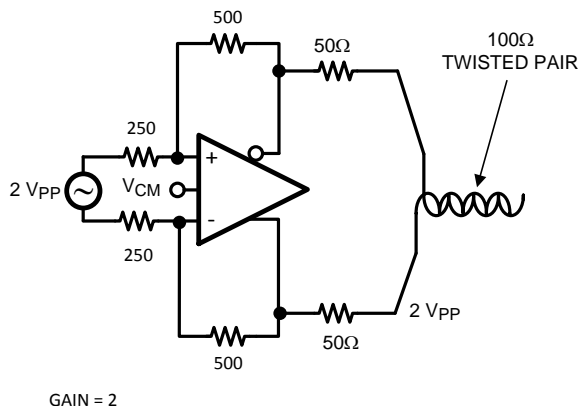

Figure 24. Fully Differential Cable Driver

With up to 15  $V_{PP}$  differential output voltage swing and 80 mA of linear drive current the LMH6551 makes an excellent cable driver as shown in Figure 24. The LMH6551 is also suitable for driving differential cables from a single-ended source.

The LMH6551 requires supply bypassing capacitors as shown in Figure 25 and Figure 26. The 0.01  $\mu F$  and 0.1  $\mu F$  capacitors should be leadless SMT ceramic capacitors and should be no more than 3 mm from the supply pins. The SMT capacitors should be connected directly to a ground plane. Thin traces or small vias will reduce the effectiveness of bypass capacitors. Also shown in both figures is a capacitor from the  $V_{CM}$  pin to ground. The  $V_{CM}$  pin is a high impedance input to a buffer which sets the output common-mode voltage. Any noise on this input is transferred directly to the output. Output common-mode noise will result in loss of dynamic range, degraded CMRR, degraded Balance and higher distortion. The  $V_{CM}$  pin should be bypassed even if the pin is not used. There is an internal resistive divider on chip to set the output common-mode voltage to the mid point of the supply pins. The impedance looking into this pin is approximately 25 k $\Omega$ . If a different output common-mode voltage is desired drive this pin with a clean, accurate voltage reference.

Typical Applications (continued)

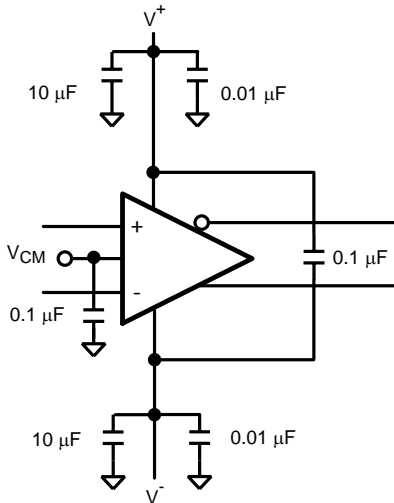

Figure 25. Split Supply Bypassing Capacitors

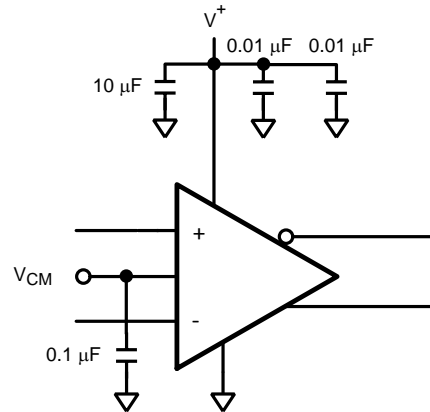

Figure 26. Single Supply Bypassing Capacitors

9.2.1.2.2 Capacitive Drive

As noted in [Driving Analog-to-Digital Converters](#), capacitive loads should be isolated from the amplifier output with small valued resistors. This is particularly the case when the load has a resistive component that is 500 Ω or higher. A typical ADC has capacitive components of around 10 pF and the resistive component could be 1000 Ω or higher. If driving a transmission line, such as 50-Ω coaxial or 100-Ω twisted pair, using matching resistors will be sufficient to isolate any subsequent capacitance. For other applications see [Figure 28](#) and [Figure 4](#) in [Typical Performance Characteristics](#).

9.2.1.3 Application Curves

Many application circuits will have capacitive loading. As shown in [Figure 4](#), amplifier bandwidth is reduced with increasing capacitive load, so parasitic capacitance should be strictly limited.

In order to guarantee stability resistance should be added between the capacitive load and the amplifier output pins. The value of the resistor is dependent on the amount of capacitive load as shown in [Figure 5](#). This resistive value is a suggestion. System testing will be required to determine the optimal value. Using a smaller resistor will retain more system bandwidth at the expense of overshoot and ringing, while larger values of resistance will reduce overshoot but will also reduce system bandwidth.

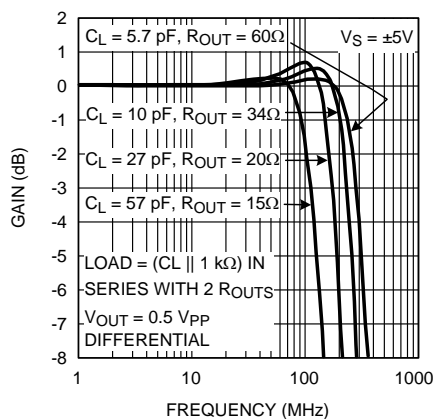

Figure 27. Frequency Response vs Capacitive Load

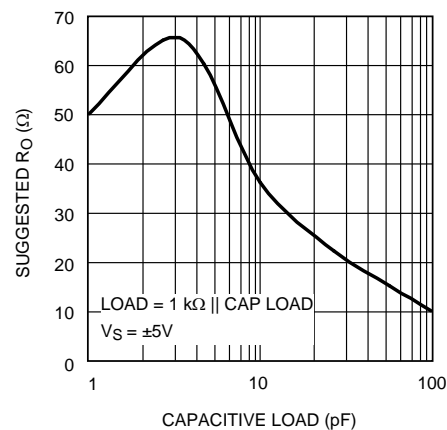

Figure 28. Suggested R<sub>OUT</sub> vs Cap Load

## Typical Applications (continued)

### 9.2.2 Single-Ended Input to Differential Output

The LMH6551 provides excellent performance as an active balun transformer. Figure 29 shows a typical application where an LMH6551 is used to produce a differential signal from a single-ended source.

In single-ended input operation the output common-mode voltage is set by the  $V_{CM}$  pin as in fully differential mode. Also, in this mode the common-mode feedback circuit must recreate the signal that is not present on the unused differential input pin. Figure 22 is the measurement of the effectiveness of this process. The common-mode feedback circuit is responsible for ensuring balanced output with a single-ended input. Balance error is defined as the amount of input signal that couples into the output common mode. It is measured as the undesired output common-mode swing divided by the signal on the input. Balance error can be caused by either a channel to channel gain error, or phase error. Either condition will produce a common-mode shift. Figure 22 measures the balance error with a single-ended input as that is the most demanding mode of operation for the amplifier.

Supply and  $V_{CM}$  pin bypassing are also critical in this mode of operation. See the above section on *Fully Differential Operation* for bypassing recommendations and also see Figure 25 and Figure 26 for recommended supply bypassing configurations.

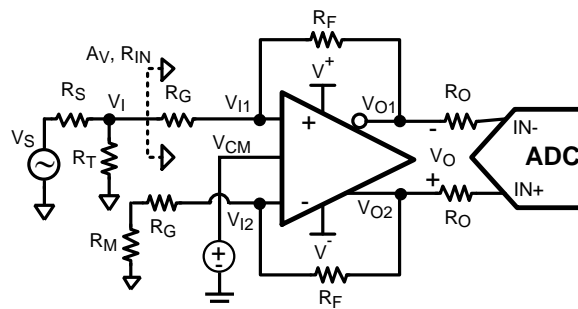

#### Conditions :

$$R_S = R_T || R_{IN}$$

$$R_M = R_T || R_S$$

#### Definitions :

$$\beta_1 = \frac{R_G}{R_G + R_F}$$

$$\beta_2 = \frac{R_G + R_M}{R_G + R_M + R_F}$$

$$A_v = \frac{V_O}{V_I} = \frac{2(1-\beta_1)}{\beta_1 + \beta_2} \cong \frac{R_F}{R_G} \text{ for } R_M \ll R_G$$

$$R_{IN} = \frac{2R_G + R_M(1-\beta_2)}{1+\beta_2} = \frac{R_G(1+\frac{\beta_2}{\beta_1})}{1+\beta_2} \cong \frac{2R_G(1+A_v)}{2+A_v} \text{ for } R_M \ll R_G$$

$$V_{OCM} = V_{CM} = \frac{V_{O1} + V_{O2}}{2} \text{ (by design)}$$

$$V_{ICM} = \frac{V_{I1} + V_{I2}}{2} = V_{OCM} \cdot \beta_2 \cong \frac{V_{OCM}}{1+A_v} \text{ for } R_M \ll R_G$$

Figure 29. Single-Ended In to Differential Out

## Typical Applications (continued)

### 9.2.3 Single Supply Operation

The input stage of the LMH6551 has a built in offset of 0.7 V towards the lower supply to accommodate single supply operation with single-ended inputs. As shown in Figure 29, the input common-mode voltage is less than the output common voltage. It is set by current flowing through the feedback network from the device output. The input common-mode range of 0.4 V to 3.2 V places constraints on gain settings. Possible solutions to this limitation include AC coupling the input signal, using split power supplies and limiting stage gain. AC coupling with single supply is shown in Figure 30.

In Figure 29 closed loop gain =  $V_O / V_I \approx R_F / R_G$ , where  $V_I = V_S / 2$ , as long as  $R_M \ll R_G$ . Note that in single-ended to differential operation  $V_I$  is measured single-ended while  $V_O$  is measured differentially. This means that gain is really 1/2 or 6 dB less when measured on either of the output pins separately. Additionally, note that the input signal at  $R_T$  (labeled as  $V_I$ ) is 1/2 of  $V_S$  when  $R_T$  is chosen to match  $R_S$  to  $R_{IN}$ .

$V_{ICM} = \text{Input common-mode voltage} = (V_{I1} + V_{I2}) / 2$ .

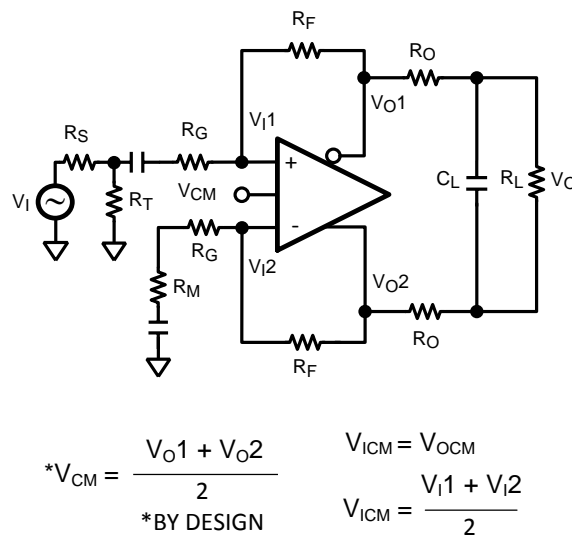

**Figure 30. AC-Coupled for Single Supply Operation**

## Typical Applications (continued)

### 9.2.4 Driving Analog-to-Digital Converters

Analog-to-digital converters (ADC) present challenging load conditions. They typically have high-impedance inputs with large and often variable capacitive components. As well, there are usually current spikes associated with switched capacitor or sample and hold circuits. [Figure 31](#) shows a typical circuit for driving an ADC. The two 56-Ω resistors serve to isolate the capacitive loading of the ADC from the amplifier and ensure stability. In addition, the resistors form part of a low pass filter which helps to provide anti alias and noise reduction functions. The two 39-pF capacitors help to smooth the current spikes associated with the internal switching circuits of the ADC and also are a key component in the low pass filtering of the ADC input. In the circuit of [Figure 31](#) the cutoff frequency of the filter is  $1 / (2 * \pi * 56 \Omega * (39 \text{ pF} + 14 \text{ pF})) = 53 \text{ MHz}$  (which is slightly less than the sampling frequency). Note that the ADC input capacitance must be factored into the frequency response of the input filter, and that being a differential input the effective input capacitance is double. Also as shown in [Figure 31](#) the input capacitance to many ADCs is variable based on the clock cycle. See the data sheet for your particular ADC for details.

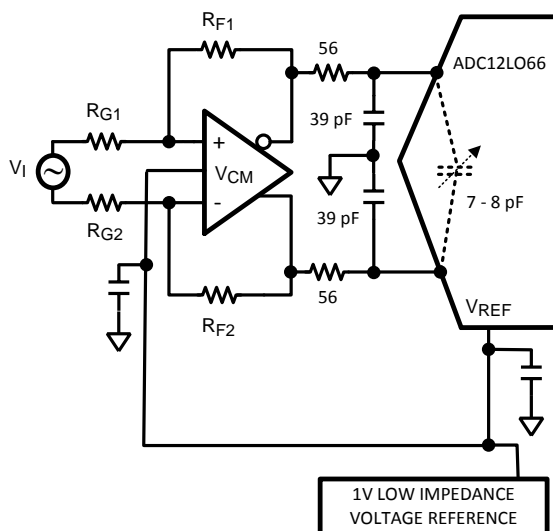

Figure 31. Driving an ADC

The amplifier and ADC should be located as closely together as possible. Both devices require that the filter components be in close proximity to them. The amplifier needs to have minimal parasitic loading on the output traces and the ADC is sensitive to high frequency noise that may couple in on its input lines. Some high performance ADCs have an input stage that has a bandwidth of several times its sample rate. The sampling process results in all input signals presented to the input stage mixing down into the Nyquist range (DC to  $F_s/2$ ). See [AN-236](#) for more details on the subsampling process and the requirements this imposes on the filtering necessary in your system.

## Typical Applications (continued)

### 9.2.5 Using Transformers

Transformers are useful for impedance transformation as well as for single to differential, and differential to single-ended conversion. A transformer can be used to step up the output voltage of the amplifier to drive very high impedance loads as shown in Figure 32. Figure 34 shows the opposite case where the output voltage is stepped down to drive a low-impedance load.

Transformers have limitations that must be considered before choosing to use one. Compared to a differential amplifier, the most serious limitations of a transformer are the inability to pass DC and balance error (which causes distortion and gain errors). For most applications the LMH6551 will have adequate output swing and drive current and a transformer will not be desirable. Transformers are used primarily to interface differential circuits to 50-Ω single-ended test equipment to simplify diagnostic testing.

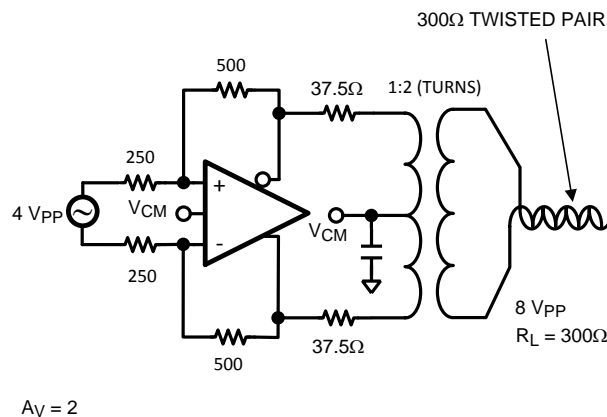

Figure 32. Transformer Out High-Impedance Load

$$V_L = \frac{V_{IN} * A_V * N}{\left( \frac{2 R_{OUT} * N^2}{R_L} + 1 \right)}$$

WHERE  $V_{IN}$  = DIFFERENTIAL INPUT VOLTAGE

$$N = \text{TRANSFORMER TURNS RATIO} = \left( \frac{\text{SECONDARY}}{\text{PRIMARY}} \right)$$

$A_V$  = CLOSED LOOP AMPLIFIER GAIN

$R_{OUT}$  = SERIES OUTPUT MATCHING RESISTOR

$R_L$  = LOAD RESISTOR

$V_L$  = VOLTAGE ACROSS LOAD RESISTOR

Figure 33. Calculating Transformer Circuit Net Gain

Typical Applications (continued)

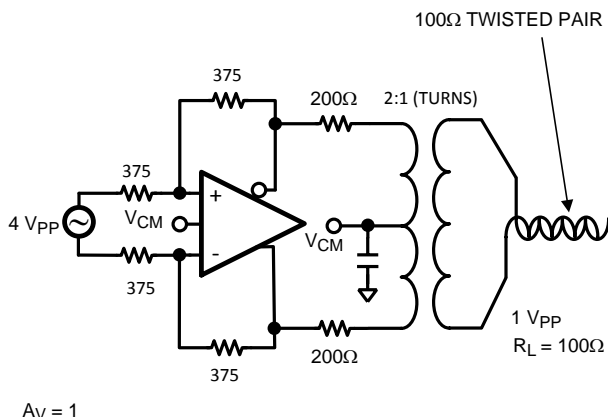

Figure 34. Transformer Out Low-Impedance Load

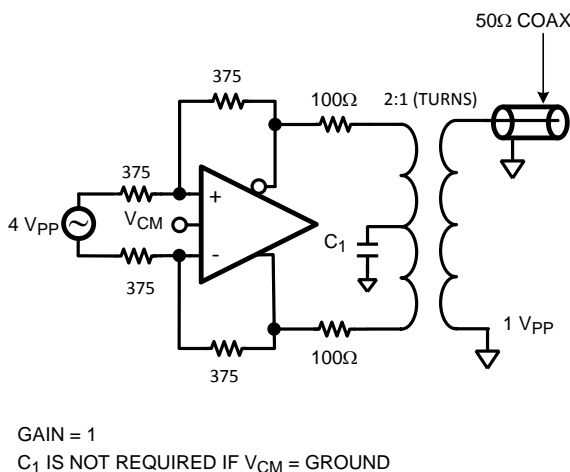

Figure 35. Driving 50-ohm Test Equipment

## 10 Power Supply Recommendations

The LMH6551 can be used with any combination of positive and negative power supplies as long as the combined supply voltage is between 4.5 V and 12 V. The LMH6551 will provide best performance when the output voltage is set at the mid supply voltage, and when the total supply voltage is between 9 V and 12 V. When selecting a supply voltage that is less than 9 V, it is important to consider both the input common-mode voltage range as well as the output voltage range.

Power supply bypassing as shown in Figure 25 and Figure 26 is important and power supply regulation should be within 5% or better when using a supply voltage near the edges of the operating range.

## 11 Layout

### 11.1 Layout Guidelines

The LMH6551 is a very high performance amplifier. In order to get maximum benefit from the differential circuit architecture, board layout and component selection is very critical. The circuit board should have a low inductance ground plane and well bypassed broad supply lines. External components should be leadless surface mount types. The feedback network and output matching resistors should be composed of short traces and precision resistors (0.1%). The output matching resistors should be placed within 3-4 mm of the amplifier as should the supply bypass capacitors. The LMH730154 evaluation board is an example of good layout techniques.

The LMH6551 is sensitive to parasitic capacitances on the amplifier inputs and to a lesser extent on the outputs as well. Ground and power plane metal should be removed from beneath the amplifier and from beneath  $R_F$  and  $R_G$ .

With any differential signal path symmetry is very important. Even small amounts of asymmetry will contribute to distortion and balance errors.

Texas Instruments offers evaluation board(s) to aid in device testing and characterization and as a guide for proper layout. Generally, a good high frequency layout will keep power supply and ground traces away from the inverting input and output pins. Parasitic capacitances on these nodes to ground will cause frequency response peaking and possible circuit oscillations.

### 11.2 Layout Example

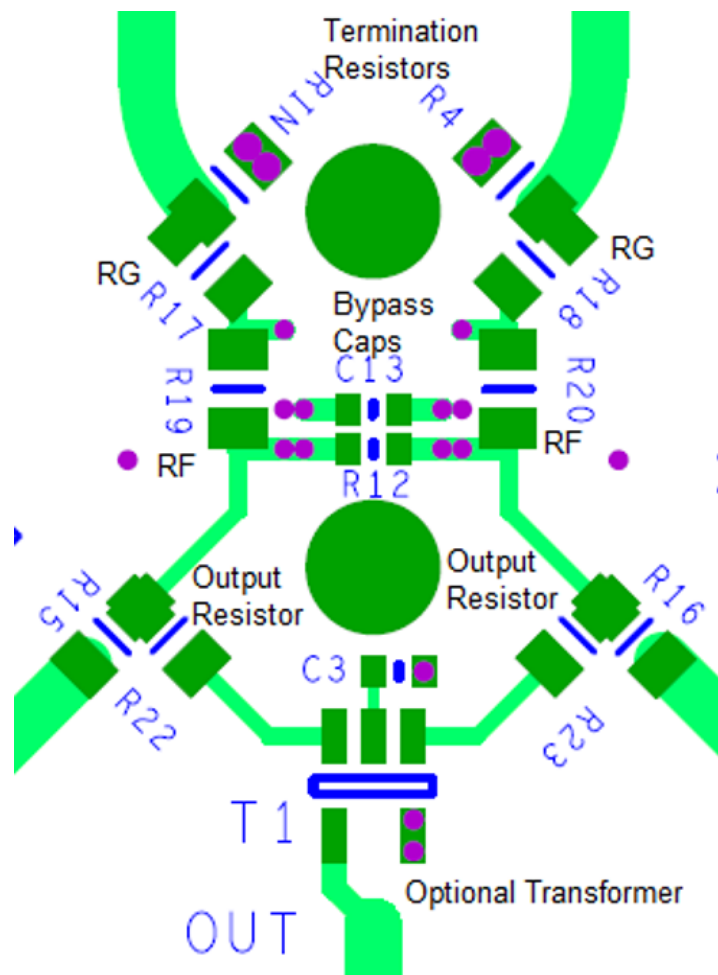

**Figure 36. Layout Schematic**

### 11.3 Power Dissipation

The LMH6551 is optimized for maximum speed and performance in the small form factor of the standard SOIC package, and is essentially a dual channel amplifier. To ensure maximum output drive and highest performance, thermal shutdown is not provided. Therefore, it is of utmost importance to make sure that the  $T_{JMAX}$  of 150°C is never exceeded due to the overall power dissipation.

Follow these steps to determine the Maximum power dissipation for the LMH6551:

1. Calculate the quiescent (no-load) power:

$$P_{AMP} = I_{CC} * (V_S)$$

where

- $V_S = V^+ - V^-$  (1)

Be sure to include any current through the feedback network if  $V_{OCM}$  is not mid rail.

2. Calculate the RMS power dissipated in each of the output stages:

$$P_D (rms) = rms ((V_S - V_{OUT}^+) * I_{OUT}^+) + rms ((V_S - V_{OUT}^-) * I_{OUT}^-)$$

where

- $V_{OUT}$  and  $I_{OUT}$  are the voltage and the current measured at the output pins of the differential amplifier as if they were single-ended amplifiers and  $V_S$  is the total supply voltage (2)

3. Calculate the total RMS power:

$$P_T = P_{AMP} + P_D (3)$$

The maximum power that the LMH6551 package can dissipate at a given temperature can be derived with the following equation:

$$P_{MAX} = (150^\circ - T_{AMB}) / \theta_{JA}$$

where

- $T_{AMB}$  = Ambient temperature (°C)
- $\theta_{JA}$  = Thermal resistance, from junction to ambient, for a given package (°C/W)
- For the SOIC package  $\theta_{JA}$  is 150°C/W. (4)

---

#### NOTE

If  $V_{CM}$  is not 0 V then there will be quiescent current flowing in the feedback network. This current should be included in the thermal calculations and added into the quiescent power dissipation of the amplifier.

---

### 11.4 ESD Protection

The LMH6551 is protected against electrostatic discharge (ESD) on all pins. The LMH6551 will survive 2000 V Human Body model and 200 V Machine model events. Under normal operation the ESD diodes have no effect on circuit performance. There are occasions, however, when the ESD diodes will be evident. If the LMH6551 is driven by a large signal while the device is powered down the ESD diodes will conduct. The current that flows through the ESD diodes will either exit the chip through the supply pins or will flow through the device, hence it is possible to power up a chip with a large signal applied to the input pins.

## 12 Device and Documentation Support

### 12.1 Documentation Support

#### 12.1.1 Related Documentation

For related documentation, see the following:

- *OA-15 Frequent Faux Pas in Applying Wideband Current Feedback Amplifiers*, [SNOA367](#)
- *AN-236 An Introduction to the Sampling Theorem*, [SNAA079](#)

### 12.2 Trademarks

LMH is a trademark of Texas Instruments.

All other trademarks are the property of their respective owners.

### 12.3 Electrostatic Discharge Caution



These devices have limited built-in ESD protection. The leads should be shorted together or the device placed in conductive foam during storage or handling to prevent electrostatic damage to the MOS gates.

### 12.4 Glossary

[SLYZ022](#) — *TI Glossary*.

This glossary lists and explains terms, acronyms, and definitions.

## 13 Mechanical, Packaging, and Orderable Information

The following pages include mechanical, packaging, and orderable information. This information is the most current data available for the designated devices. This data is subject to change without notice and revision of this document. For browser-based versions of this data sheet, refer to the left-hand navigation.

**PACKAGING INFORMATION**

Orderable Device	Status (1)	Package Type	Package Drawing	Pins	Package Qty	Eco Plan (2)	Lead/Ball Finish (6)	MSL Peak Temp (3)	Op Temp (°C)	Device Marking (4/5)	Samples
LMH6551MA/NOPB	ACTIVE	SOIC	D	8	95	Green (RoHS & no Sb/Br)	CU SN	Level-1-260C-UNLIM	-40 to 85	LMH6551MA	<a href="#">Samples</a>
LMH6551MAX/NOPB	ACTIVE	SOIC	D	8	2500	Green (RoHS & no Sb/Br)	CU SN	Level-1-260C-UNLIM	-40 to 85	LMH6551MA	<a href="#">Samples</a>
LMH6551MM	NRND	VSSOP	DGK	8	1000	TBD	Call TI	Call TI	-40 to 85	AU1A	
LMH6551MM/NOPB	ACTIVE	VSSOP	DGK	8	1000	Green (RoHS & no Sb/Br)	CU SN	Level-1-260C-UNLIM	-40 to 85	AU1A	<a href="#">Samples</a>
LMH6551MMX/NOPB	ACTIVE	VSSOP	DGK	8	3500	Green (RoHS & no Sb/Br)	CU SN	Level-1-260C-UNLIM	-40 to 85	AU1A	<a href="#">Samples</a>

(1) The marketing status values are defined as follows:

**ACTIVE:** Product device recommended for new designs.

**LIFEBUY:** TI has announced that the device will be discontinued, and a lifetime-buy period is in effect.

**NRND:** Not recommended for new designs. Device is in production to support existing customers, but TI does not recommend using this part in a new design.

**PREVIEW:** Device has been announced but is not in production. Samples may or may not be available.

**OBsolete:** TI has discontinued the production of the device.

(2) Eco Plan - The planned eco-friendly classification: Pb-Free (RoHS), Pb-Free (RoHS Exempt), or Green (RoHS & no Sb/Br) - please check <http://www.ti.com/productcontent> for the latest availability information and additional product content details.

**TBD:** The Pb-Free/Green conversion plan has not been defined.

**Pb-Free (RoHS):** TI's terms "Lead-Free" or "Pb-Free" mean semiconductor products that are compatible with the current RoHS requirements for all 6 substances, including the requirement that lead not exceed 0.1% by weight in homogeneous materials. Where designed to be soldered at high temperatures, TI Pb-Free products are suitable for use in specified lead-free processes.

**Pb-Free (RoHS Exempt):** This component has a RoHS exemption for either 1) lead-based flip-chip solder bumps used between the die and package, or 2) lead-based die adhesive used between the die and leadframe. The component is otherwise considered Pb-Free (RoHS compatible) as defined above.

**Green (RoHS & no Sb/Br):** TI defines "Green" to mean Pb-Free (RoHS compatible), and free of Bromine (Br) and Antimony (Sb) based flame retardants (Br or Sb do not exceed 0.1% by weight in homogeneous material)

(3) MSL, Peak Temp. - The Moisture Sensitivity Level rating according to the JEDEC industry standard classifications, and peak solder temperature.

(4) There may be additional marking, which relates to the logo, the lot trace code information, or the environmental category on the device.

(5) Multiple Device Markings will be inside parentheses. Only one Device Marking contained in parentheses and separated by a "~" will appear on a device. If a line is indented then it is a continuation of the previous line and the two combined represent the entire Device Marking for that device.

(6) Lead/Ball Finish - Orderable Devices may have multiple material finish options. Finish options are separated by a vertical ruled line. Lead/Ball Finish values may wrap to two lines if the finish value exceeds the maximum column width.

**Important Information and Disclaimer:** The information provided on this page represents TI's knowledge and belief as of the date that it is provided. TI bases its knowledge and belief on information provided by third parties, and makes no representation or warranty as to the accuracy of such information. Efforts are underway to better integrate information from third parties. TI has taken and continues to take reasonable steps to provide representative and accurate information but may not have conducted destructive testing or chemical analysis on incoming materials and chemicals. TI and TI suppliers consider certain information to be proprietary, and thus CAS numbers and other limited information may not be available for release.

In no event shall TI's liability arising out of such information exceed the total purchase price of the TI part(s) at issue in this document sold by TI to Customer on an annual basis.

**TAPE AND REEL INFORMATION**

**QUADRANT ASSIGNMENTS FOR PIN 1 ORIENTATION IN TAPE**

\*All dimensions are nominal

Device	Package Type	Package Drawing	Pins	SPQ	Reel Diameter (mm)	Reel Width W1 (mm)	A0 (mm)	B0 (mm)	K0 (mm)	P1 (mm)	W (mm)	Pin1 Quadrant
LMH6551MAX/NOPB	SOIC	D	8	2500	330.0	12.4	6.5	5.4	2.0	8.0	12.0	Q1
LMH6551MM	VSSOP	DGK	8	1000	178.0	12.4	5.3	3.4	1.4	8.0	12.0	Q1
LMH6551MM/NOPB	VSSOP	DGK	8	1000	178.0	12.4	5.3	3.4	1.4	8.0	12.0	Q1
LMH6551MMX/NOPB	VSSOP	DGK	8	3500	330.0	12.4	5.3	3.4	1.4	8.0	12.0	Q1

**TAPE AND REEL BOX DIMENSIONS**

\*All dimensions are nominal

Device	Package Type	Package Drawing	Pins	SPQ	Length (mm)	Width (mm)	Height (mm)
LMH6551MAX/NOPB	SOIC	D	8	2500	367.0	367.0	35.0
LMH6551MM	VSSOP	DGK	8	1000	210.0	185.0	35.0
LMH6551MM/NOPB	VSSOP	DGK	8	1000	210.0	185.0	35.0
LMH6551MMX/NOPB	VSSOP	DGK	8	3500	367.0	367.0	35.0



D0008A

# PACKAGE OUTLINE

SOIC - 1.75 mm max height

SMALL OUTLINE INTEGRATED CIRCUIT



4214825/C 02/2019

### NOTES:

1. Linear dimensions are in inches [millimeters]. Dimensions in parenthesis are for reference only. Controlling dimensions are in inches. Dimensioning and tolerancing per ASME Y14.5M.
2. This drawing is subject to change without notice.
3. This dimension does not include mold flash, protrusions, or gate burrs. Mold flash, protrusions, or gate burrs shall not exceed .006 [0.15] per side.
4. This dimension does not include interlead flash.
5. Reference JEDEC registration MS-012, variation AA.

# EXAMPLE BOARD LAYOUT

D0008A

SOIC - 1.75 mm max height

SMALL OUTLINE INTEGRATED CIRCUIT



LAND PATTERN EXAMPLE  
 EXPOSED METAL SHOWN  
 SCALE:8X



SOLDER MASK DETAILS

4214825/C 02/2019

NOTES: (continued)

- 6. Publication IPC-7351 may have alternate designs.
- 7. Solder mask tolerances between and around signal pads can vary based on board fabrication site.

# EXAMPLE STENCIL DESIGN

D0008A

SOIC - 1.75 mm max height

SMALL OUTLINE INTEGRATED CIRCUIT



SOLDER PASTE EXAMPLE  
BASED ON .005 INCH [0.125 MM] THICK STENCIL  
SCALE:8X

4214825/C 02/2019

NOTES: (continued)

8. Laser cutting apertures with trapezoidal walls and rounded corners may offer better paste release. IPC-7525 may have alternate design recommendations.
9. Board assembly site may have different recommendations for stencil design.

DGK (S-PDSO-G8)

PLASTIC SMALL-OUTLINE PACKAGE

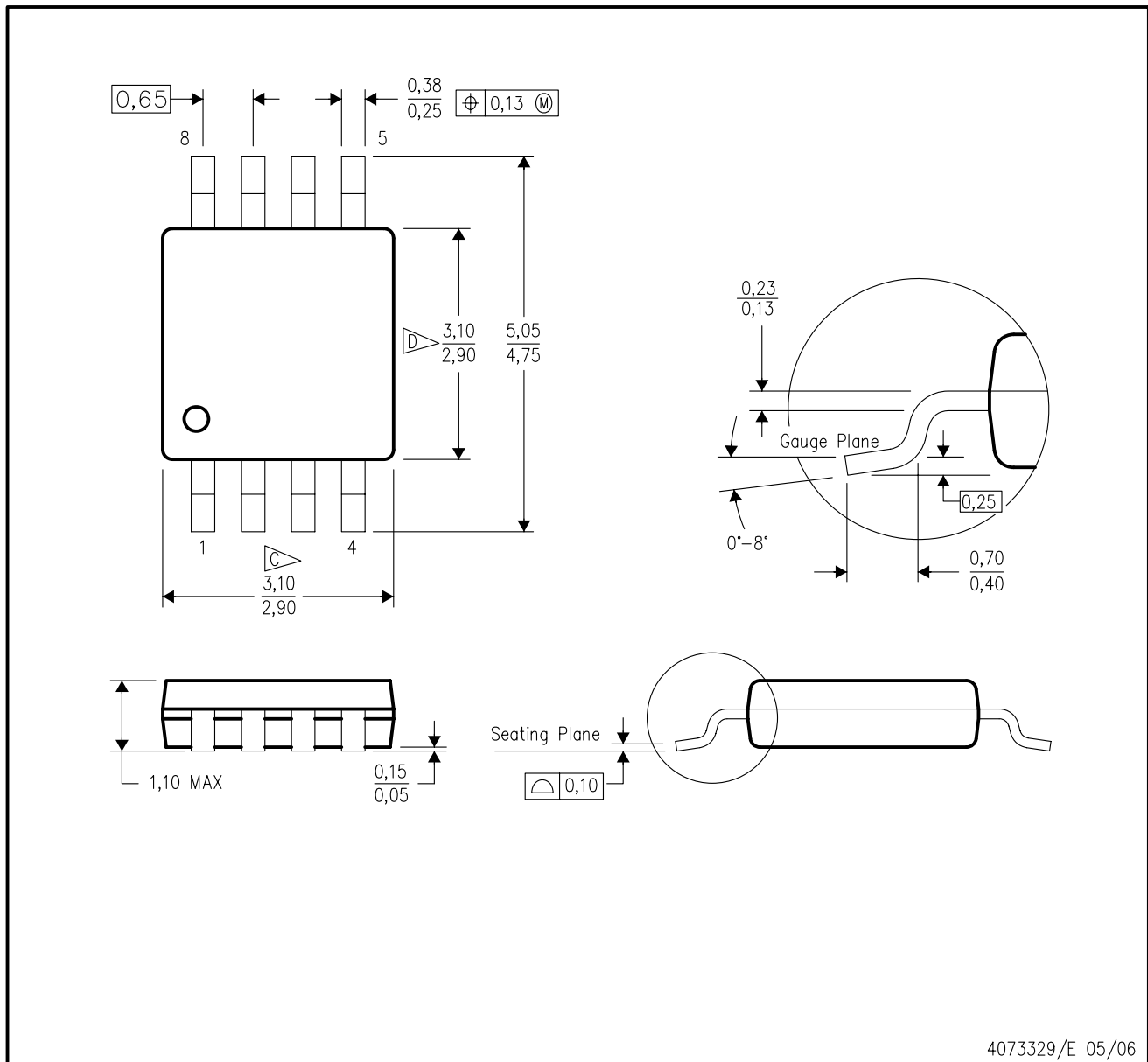

4073329/E 05/06

- NOTES:
- A. All linear dimensions are in millimeters.
  - B. This drawing is subject to change without notice.
  - C. Body length does not include mold flash, protrusions, or gate burrs. Mold flash, protrusions, or gate burrs shall not exceed 0.15 per end.
  - D. Body width does not include interlead flash. Interlead flash shall not exceed 0.50 per side.
  - E. Falls within JEDEC MO-187 variation AA, except interlead flash.



- NOTES:
- A. All linear dimensions are in millimeters.
  - B. This drawing is subject to change without notice.
  - C. Publication IPC-7351 is recommended for alternate designs.
  - D. Laser cutting apertures with trapezoidal walls and also rounding corners will offer better paste release. Customers should contact their board assembly site for stencil design recommendations. Refer to IPC-7525 for other stencil recommendations.
  - E. Customers should contact their board fabrication site for solder mask tolerances between and around signal pads.

## IMPORTANT NOTICE AND DISCLAIMER

TI PROVIDES TECHNICAL AND RELIABILITY DATA (INCLUDING DATASHEETS), DESIGN RESOURCES (INCLUDING REFERENCE DESIGNS), APPLICATION OR OTHER DESIGN ADVICE, WEB TOOLS, SAFETY INFORMATION, AND OTHER RESOURCES "AS IS" AND WITH ALL FAULTS, AND DISCLAIMS ALL WARRANTIES, EXPRESS AND IMPLIED, INCLUDING WITHOUT LIMITATION ANY IMPLIED WARRANTIES OF MERCHANTABILITY, FITNESS FOR A PARTICULAR PURPOSE OR NON-INFRINGEMENT OF THIRD PARTY INTELLECTUAL PROPERTY RIGHTS.

These resources are intended for skilled developers designing with TI products. You are solely responsible for (1) selecting the appropriate TI products for your application, (2) designing, validating and testing your application, and (3) ensuring your application meets applicable standards, and any other safety, security, or other requirements. These resources are subject to change without notice. TI grants you permission to use these resources only for development of an application that uses the TI products described in the resource. Other reproduction and display of these resources is prohibited. No license is granted to any other TI intellectual property right or to any third party intellectual property right. TI disclaims responsibility for, and you will fully indemnify TI and its representatives against, any claims, damages, costs, losses, and liabilities arising out of your use of these resources.

TI's products are provided subject to TI's Terms of Sale ([www.ti.com/legal/termsofsale.html](http://www.ti.com/legal/termsofsale.html)) or other applicable terms available either on [ti.com](http://ti.com) or provided in conjunction with such TI products. TI's provision of these resources does not expand or otherwise alter TI's applicable warranties or warranty disclaimers for TI products.

Mailing Address: Texas Instruments, Post Office Box 655303, Dallas, Texas 75265  
Copyright © 2019, Texas Instruments Incorporated

## Looking for pricing, stock, or lifecycle information?

Click below to explore more details on WIN SOURCE:

 [View LMH6551MAX/NOPB on WIN SOURCE](#)

 [Texas Instruments](#) Information

## Optimize Your Supply Chain with WIN SOURCE Solutions

-  Global Sourcing Solution
-  Obsolete Management
-  Cost Control Management
-  Shortage Management
-  Alternative Solution
-  Excess Inventory Management