



**THE DATASHEET OF
LMV301MGX/NOPB**



LMV301 Low Input Bias Current, 1.8V Op Amp w/ Rail-to-Rail Output

Check for Samples: [LMV301](#)

FEATURES

- **Input Bias Current: 0.182 pA**
- **Gain Bandwidth Product: 1 MHz**
- **Supply Voltage at 1.8V: 1.8 to 5 V**
- **Supply Current: 150 μ A**
- **Input Referred Voltage Noise at 1kHz: 40nV/ $\sqrt{\text{Hz}}$**
- **DC Gain (600 Ω Load): 100 dB**
- **Output Voltage Range at 1.8V: 0.024 to 1.77 V**
- **Input Common-Mode Voltage Range: -0.3 to \pm 1.2 V**

APPLICATIONS

- **Thermocouple Amplifiers**
- **Photo Current Amplifiers**
- **Transducer Amplifiers**
- **Sample and Hold Circuits**
- **Low Frequency Active Filters**

DESCRIPTION

The LMV301 CMOS operational amplifier is ideal for single supply, low voltage operation with an ensured operating voltage range from 1.8V to 5V. The low input bias current of less than 0.182pA typical, eliminates input voltage errors that may originate from small input signals. This makes the LMV301 ideal for electrometer applications requiring low input leakage such as sensitive photodetection transimpedance amplifiers and sensor amplifiers. The LMV301 also features a rail-to-rail output voltage swing in addition to a input common-mode range that includes ground. The LMV301 will drive a 600 Ω resistive load and up to 1000pF capacitive load in unity gain follower applications. The low supply voltage also makes the LMV301 well suited for portable two-cell battery systems and single cell Li-Ion systems.

The LMV301 exhibits excellent speed-power ratio, achieving 1MHz at unity gain with low supply current. The high DC gain of 100dB makes it ideal for other low frequency applications.

The LMV301 is offered in a space saving SC70 package, which is only 2.0X2.1X1.0mm. It is also similar to the LMV321 except the LMV301 has a CMOS input.

Connection Diagram

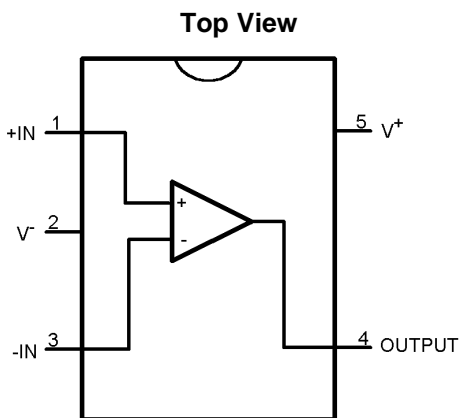

Figure 1. SC70-5 Package
See Package Number DCK0005A

Applications Circuit

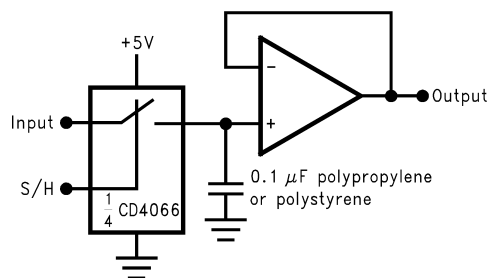

Figure 2. Low Leakage Sample and Hold



These devices have limited built-in ESD protection. The leads should be shorted together or the device placed in conductive foam during storage or handling to prevent electrostatic damage to the MOS gates.



Please be aware that an important notice concerning availability, standard warranty, and use in critical applications of Texas Instruments semiconductor products and disclaimers thereto appears at the end of this data sheet.

All trademarks are the property of their respective owners.

Absolute Maximum Ratings⁽¹⁾⁽²⁾

ESD Tolerance ⁽³⁾	Machine Model	200V
	Human Body Model	2000V
Differential Input Voltage		±Supply Voltage
Supply Voltage ($V^+ - V^-$)		5.5V
Output Short Circuit to $V^{+ (4)}$		
Output Short Circuit to $V^{- (4)}$		
Storage Temperature Range		-65°C to 150°C
Mounting Temperature	Infrared or Convection (20 sec)	235°C
Junction Temperature ⁽⁵⁾		150°C

- (1) Absolute Maximum Ratings indicate limits beyond which damage to the device may occur. Operating Ratings indicate conditions for which the device is intended to be functional, but specific performance is not ensured. For ensured specifications and the test conditions, see the Electrical Characteristics.
- (2) If Military/Aerospace specified devices are required, please contact the Texas Instruments Sales Office/Distributors for availability and specifications.
- (3) Human body model, 1.5k Ω in series with 100pF. Machine model, 200 Ω in series with 100pF.
- (4) Applies to both single supply operation. Continuous short circuit operation at elevated ambient temperature can result in exceeding the maximum allowed junction temperature of 150°C. Output currents in excess of 45mA over long term may adversely affect reliability.
- (5) The maximum power dissipation is a function of $T_{J(MAX)}$, θ_{JA} , and T_A . The maximum allowable power dissipation at any ambient temperature is $P_D = (T_{J(MAX)} - T_A)\theta_{JA}$. All numbers apply for packages soldered directly into a PC board.

Operating Ratings⁽¹⁾

Supply Voltage			1.8V to 5.0V
Temperature Range			-40°C \leq T_J \leq +85°C
Thermal Resistance (θ_{JA})	Ultra Tiny SC70-5 Package	5-pin Surface Mount	478°C/W

- (1) Absolute Maximum Ratings indicate limits beyond which damage to the device may occur. Operating Ratings indicate conditions for which the device is intended to be functional, but specific performance is not ensured. For ensured specifications and the test conditions, see the Electrical Characteristics.

1.8V DC Electrical Characteristics

Unless otherwise specified, all limits ensured for $T_J = 25^\circ\text{C}$. $V^+ = 1.8\text{V}$, $V^- = 0\text{V}$, $V_{\text{CM}} = V^+/2$, $V_O = V^+/2$, and $R_L > 1\text{M}\Omega$.

Boldface limits apply at the temperature extremes.

Parameter		Test Conditions		Min ⁽¹⁾	Typ ⁽²⁾	Max ⁽¹⁾	Units
V_{OS}	Input Offset Voltage	$V_{\text{CM}} = 0.4\text{V}$, $V^+ = 1.3\text{V}$, $V^- = -0.5\text{V}$			0.9	8 9	mV
I_{B}	Input Bias Current				0.182	35 50	pA
I_{S}	Supply Current	$V_{\text{CM}} = 0.4\text{V}$, $V^+ = 1.3\text{V}$, $V^- = -0.5\text{V}$			150	250 275	μA
CMRR	Common Mode Rejection Ratio	$0.3\text{V} \leq V_{\text{CM}} \leq 0.9\text{V}$		62 60	108		dB
PSRR	Power Supply Rejection Ratio	$1.8\text{V} \leq V^+ \leq 5\text{V}$, $0.9 \leq V_{\text{CM}} \leq 2.5\text{V}$		67 62	110		dB
V_{CM}	Input Common-Mode Voltage Range	For CMRR $\geq 50\text{dB}$		-0.3 0		0.6	V
A_V	Large Signal Voltage Gain Sourcing	$R_L = 600\Omega$ to 0V , $V^+ = 1.2\text{V}$, $V^- = -0.6\text{V}$, $V_O = -0.2\text{V}$ to 0.8V , $V_{\text{CM}} = 0\text{V}$		80 75	119		dB
		$R_L = 2\text{k}\Omega$ to 0V , $V^+ = 1.2\text{V}$, $V^- = -0.6\text{V}$, V_O $= -0.2\text{V}$ to 0.8V , $V_{\text{CM}} = 0\text{V}$		80 75	111		
	Sinking	$R_L = 600\Omega$ to 0V , $V^+ = 1.2\text{V}$, $V^- = -0.6\text{V}$, $V_O = -0.2\text{V}$ to 0.8V , $V_{\text{CM}} = 0\text{V}$		80 75	94		dB
		$R_L = 2\text{k}\Omega$ to 0V , $V^+ = 1.2\text{V}$, $V^- = -0.6\text{V}$, V_O $= -0.2\text{V}$ to 0.8V , $V_{\text{CM}} = 0\text{V}$		80 75	96		
V_O	Output Swing	$R_L = 600\Omega$ to 0.9V $V_{\text{IN}} = \pm 100\text{mV}$	V_{OH}	1.65 1.63	1.72		V
			V_{OL}		0.074	0.100	V
		$R_L = 2\text{k}\Omega$ to 0.9V $V_{\text{IN}} = \pm 100\text{mV}$	V_{OH}	1.75 1.74	1.77		V
			V_{OL}		0.024	0.035 0.040	V
I_O	Output Short Circuit Current	Sourcing, $V_O = 0\text{V}$, $V_{\text{IN}} = 100\text{mV}$		4 3.3	8.4		mA
		Sinking, $V_O = 1.8\text{V}$, $V_{\text{IN}} = -100\text{mV}$		7	9.8		mA

(1) All limits are ensured by testing or statistical analysis.

(2) Typical value represent the most likely parametric norm.

1.8V AC Electrical Characteristics

Unless otherwise specified, all limits ensured for $T_J = 25^\circ\text{C}$. $V^+ = 1.8\text{V}$, $V^- = 0\text{V}$, $V_{\text{CM}} = V^+/2$, $V_O = V^+/2$, and $R_L > 1\text{M}\Omega$.

Boldface limits apply at the temperature extremes.

Parameter	Test Conditions		Typ ⁽¹⁾	Units
SR	Slew Rate	See ⁽²⁾	0.57	V/ μs
GBW	Gain Bandwidth Product		1	MHz
ϕ_m	Phase Margin		60	Deg
G_m	Gain Margin		10	dB
e_n	Input-Referred Voltage Noise	$f = 1\text{kHz}$, $V_{\text{CM}} = 0.5\text{V}$ $f = 100\text{kHz}$	40 30	nV/ $\sqrt{\text{Hz}}$
THD	Total Harmonic Distortion	$f = 1\text{kHz}$, $A_V = +1$ $R_L = 600\text{k}\Omega$, $V_{\text{IN}} = 1\text{V}_{\text{PP}}$	0.089	%

(1) Typical value represent the most likely parametric norm.

(2) $V^+ = 5\text{V}$. Connected as voltage follower with 5V step input. Number specified is the slower of the positive and negative slew rates.

2.7V DC Electrical Characteristics

Unless otherwise specified, all limits ensured for $T_J = 25^\circ\text{C}$. $V^+ = 2.7\text{V}$, $V^- = 0\text{V}$, $V_{\text{CM}} = V^+/2$, $V_O = V^+/2$, and $R_L > 1\text{M}\Omega$.

Boldface limits apply at the temperature extremes.

Parameter		Test Conditions		Min ⁽¹⁾	Typ ⁽²⁾	Max ⁽¹⁾	Units	
V_{OS}	Input Offset Voltage	$V_{\text{CM}} = 0.35\text{V}$, $V^+ = 1.7\text{V}$, $V^- = -1\text{V}$			0.9	8 9	mV	
I_{B}	Input Bias Current				0.182	35 50	pA	
I_{S}	Supply Current	$V_{\text{CM}} = 0.35\text{V}$, $V^+ = 1.7\text{V}$, $V^- = -1\text{V}$			153	250 275	μA	
CMRR	Common Mode Rejection Ratio	$-0.15\text{V} \leq V_{\text{CM}} \leq 1.35\text{V}$		62 60	115		dB	
PSRR	Power Supply Rejection Ratio	$1.8\text{V} \leq V^+ \leq 5\text{V}$		67 62	110		dB	
V_{CM}	Input Common-Mode Voltage Range	For CMRR $\geq 50\text{dB}$		-0.3 0		1.5	V	
A_V	Large Signal Voltage Gain Sourcing	$R_L = 600\Omega$ to 0V , $V^+ = 1.35\text{V}$, $V^- = -1.35\text{V}$, $V_O = -1\text{V}$ to 1V , $V_{\text{CM}} = 0\text{V}$		80 75	100		dB	
		$R_L = 2\text{k}\Omega$ to 0V , $V^+ = 1.35\text{V}$, $V^- = -1.35\text{V}$, $V_O = -1\text{V}$ to 1V , $V_{\text{CM}} = 0\text{V}$		83 77	114			
	Sinking	$R_L = 600\Omega$ to 0V , $V^+ = 1.35\text{V}$, $V^- = -1.35\text{V}$, $V_O = -1\text{V}$ to 1V , $V_{\text{CM}} = 0\text{V}$		80 75	98		dB	
		$R_L = 2\text{k}\Omega$ to 0V , $V^+ = 1.35\text{V}$, $V^- = -1.35\text{V}$, $V_O = -1\text{V}$ to 1V , $V_{\text{CM}} = 0\text{V}$		80 75	99			
V_O	Output Swing	$R_L = 600\Omega$ to 1.35V $V_{\text{IN}} = \pm 100\text{mV}$	V_{OH}	2.550 2.530	2.62		V	
			V_{OL}			0.078	0.100	V
		$R_L = 2\text{k}\Omega$ to 1.35V $V_{\text{IN}} = \pm 100\text{mV}$	V_{OH}	2.650 2.640	2.675			V
			V_{OL}			0.024	0.045	V
I_O	Output Short Circuit Current	Sourcing, $V_O = 0\text{V}$, $V_{\text{IN}} = 100\text{mV}$		20 15	32		mA	
		Sinking, $V_O = 2.7\text{V}$, $V_{\text{IN}} = -100\text{mV}$		19 12	24		mA	

(1) All limits are ensured by testing or statistical analysis.

(2) Typical value represent the most likely parametric norm.

2.7V AC Electrical Characteristics

Unless otherwise specified, all limits ensured for $T_J = 25^\circ\text{C}$. $V^+ = 2.7\text{V}$, $V^- = 0\text{V}$, $V_{\text{CM}} = 1.0\text{V}$, $V_O = 1.35\text{V}$ and $R_L > 1\text{M}\Omega$.

Boldface limits apply at the temperature extremes.

Parameter		Test Conditions		Typ ⁽¹⁾	Units
SR	Slew Rate	See ⁽²⁾		0.60	$\text{V}/\mu\text{s}$
GBW	Gain Bandwidth Product			1	MHz
ϕ_m	Phase Margin			65	Deg
G_m	Gain Margin			10	dB
e_n	Input-Referred Voltage Noise	$f = 1\text{kHz}$, $V_{\text{CM}} = 0.5\text{V}$		40	$\text{nV}/\sqrt{\text{Hz}}$
		$f = 100\text{kHz}$		30	
THD	Total Harmonic Distortion	$f = 1\text{kHz}$, $A_V = +1$ $R_L = 600\text{k}\Omega$, $V_{\text{IN}} = 1\text{V}_{\text{PP}}$		0.077	%

(1) Typical value represent the most likely parametric norm.

(2) $V^+ = 5\text{V}$. Connected as voltage follower with 5V step input. Number specified is the slower of the positive and negative slew rates.

5V DC Electrical Characteristics

Unless otherwise specified, all limits ensured for $T_J = 25^\circ\text{C}$. $V^+ = 5\text{V}$, $V^- = 0\text{V}$, $V_{\text{CM}} = V^+/2$, $V_O = V^+/2$, and $R_L > 1\text{M}\Omega$.

Boldface limits apply at the temperature extremes.

Parameter		Test Conditions		Min ⁽¹⁾	Typ ⁽²⁾	Max ⁽¹⁾	Units	
V_{OS}	Input Offset Voltage	$V_{\text{CM}} = 0.5\text{V}$, $V^+ = 3\text{V}$, $V^- = -2\text{V}$			0.9	8 9	mV	
I_{B}	Input Bias Current				0.182	35 50	μA	
I_{S}	Supply Current	$V_{\text{CM}} = 0.5\text{V}$, $V^+ = 3\text{V}$, $V^- = -2\text{V}$			163	260 285	μA	
CMRR	Common Mode Rejection Ratio	$-1.3\text{V} \leq V_{\text{CM}} \leq 2.5\text{V}$		62 61	111		dB	
PSRR	Power Supply Rejection Ratio	$1.8\text{V} \leq V^+ \leq 5\text{V}$		67 62	110		dB	
V_{CM}	Input Common-Mode Voltage Range	For CMRR $\geq 50\text{dB}$		-0.3 0		3.8	V	
A_V	Large Signal Voltage Gain Sourcing	$R_L = 600\Omega$ to 0V , $V^+ = 2.5\text{V}$, $V^- = -2.5\text{V}$, $V_O = -2\text{V}$ to 2V , $V_{\text{CM}} = 0\text{V}$		86 82	117		dB	
		$R_L = 2\text{k}\Omega$ to 0V , $V^+ = 2.5\text{V}$, $V^- = -2.5\text{V}$, $V_O = -2\text{V}$ to 2V , $V_{\text{CM}} = 0\text{V}$		89 85	116			
	Sinking	$R_L = 600\Omega$ to 0V , $V^+ = 2.5\text{V}$, $V^- = -2.5\text{V}$, $V_O = -2\text{V}$ to 2V , $V_{\text{CM}} = 0\text{V}$		80 75	105		dB	
		$R_L = 2\text{k}\Omega$ to 0V , $V^+ = 2.5\text{V}$, $V^- = -2.5\text{V}$, $V_O = -2\text{V}$ to 2V , $V_{\text{CM}} = 0\text{V}$		80 75	107			
V_O	Output Swing	$R_L = 600\Omega$ to 2.5V $V_{\text{IN}} = \pm 100\text{mV}$	V_{OH}	4.850 4.840	4.893		V	
			V_{OL}			0.1	0.150 1.160	V
		$R_L = 2\text{k}\Omega$ to 2.5V $V_{\text{IN}} = \pm 100\text{mV}$	V_{OH}	4.935	4.966			V
			V_{OL}		0.034		0.065 0.075	V
I_{O}	Output Short Circuit Current	Sourcing, $V_O = 0\text{V}$, $V_{\text{IN}} = 100\text{mV}$		85 68	108		mA	
		Sinking, $V_O = 5\text{V}$, $V_{\text{IN}} = -100\text{mV}$		60 45	69		mA	

(1) All limits are ensured by testing or statistical analysis.

(2) Typical value represent the most likely parametric norm.

5V AC Electrical Characteristics

Unless otherwise specified, all limits ensured for $T_J = 25^\circ\text{C}$. $V^+ = 5\text{V}$, $V^- = 0\text{V}$, $V_{\text{CM}} = V^+/2$, $V_O = 2.5\text{V}$ and $R_L > 1\text{M}\Omega$.

Boldface limits apply at the temperature extremes.

Parameter		Test Conditions		Typ ⁽¹⁾	Units
SR	Slew Rate	See ⁽²⁾		0.66	V/ μs
GBW	Gain Bandwidth Product			1	MHz
ϕ_m	Phase Margin			70	Deg
G_m	Gain Margin			15	dB
e_n	Input-Referred Voltage Noise	$f = 1\text{kHz}$, $V_{\text{CM}} = 1\text{V}$ $f = 100\text{kHz}$		40 30	nV/ $\sqrt{\text{Hz}}$
THD	Total Harmonic Distortion	$f = 1\text{kHz}$, $A_V = +1$ $R_L = 600\Omega$, $V_O = 1V_{\text{PP}}$		0.069	%

(1) Typical value represent the most likely parametric norm.

(2) $V^+ = 5\text{V}$. Connected as voltage follower with 5V step input. Number specified is the slower of the positive and negative slew rates.

Simplified Schematic

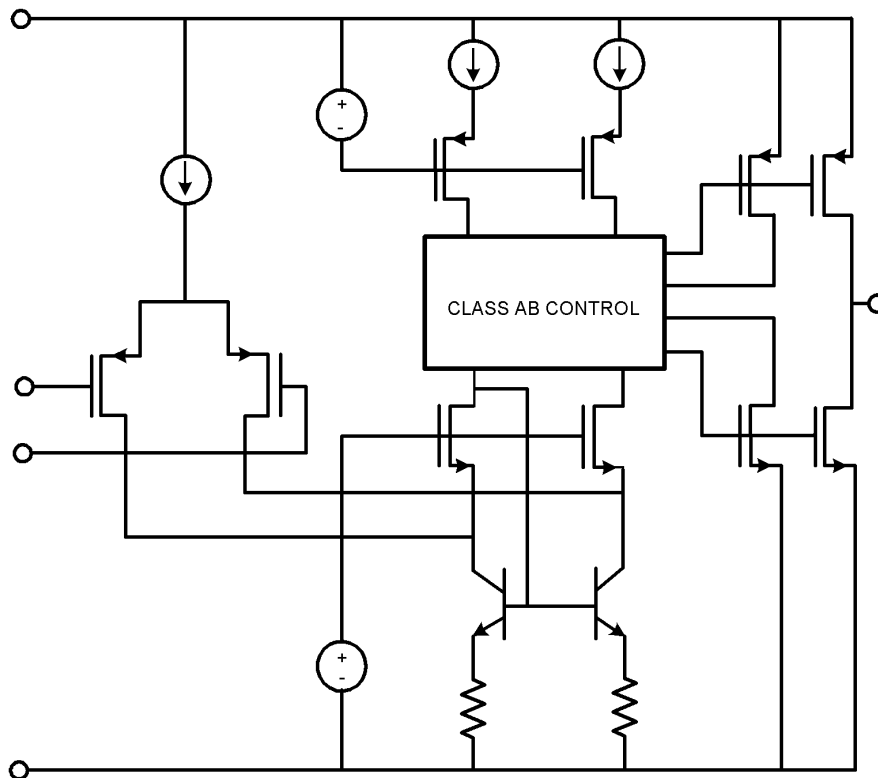

Typical Performance Characteristics

Unless otherwise specified, $T_A = 25^\circ\text{C}$.

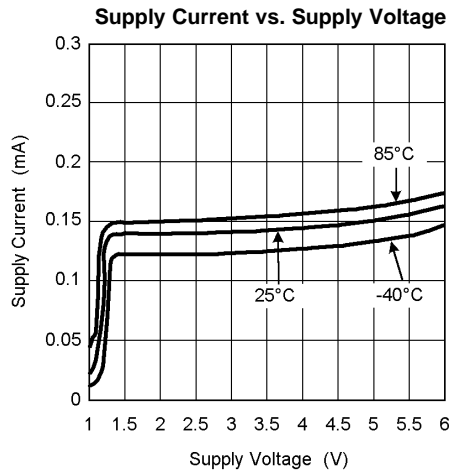

Figure 3.

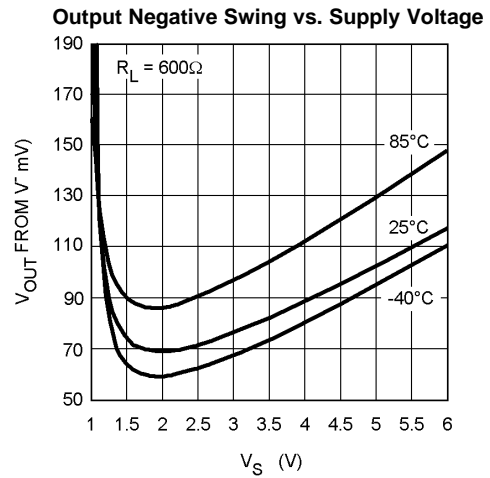

Figure 4.

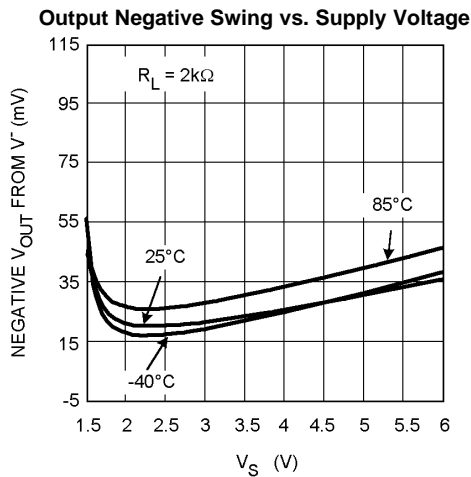

Figure 5.

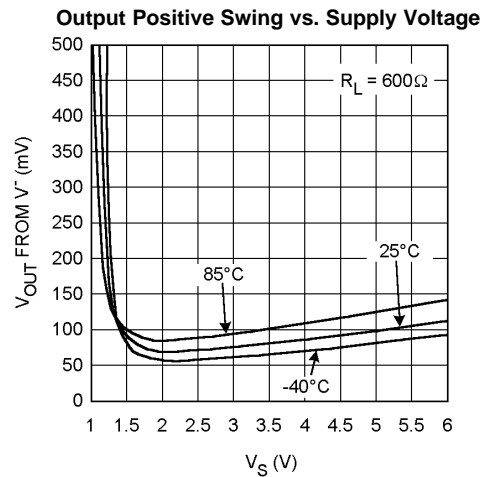

Figure 6.

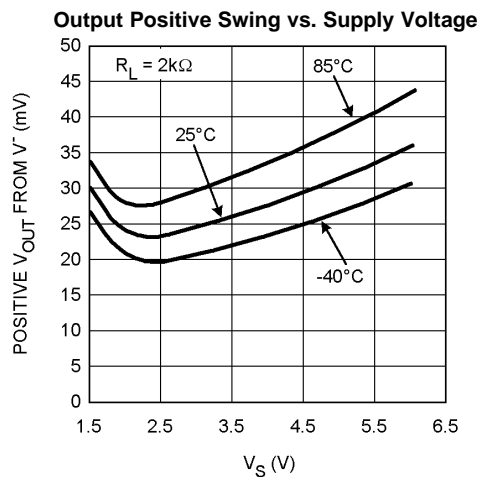

Figure 7.

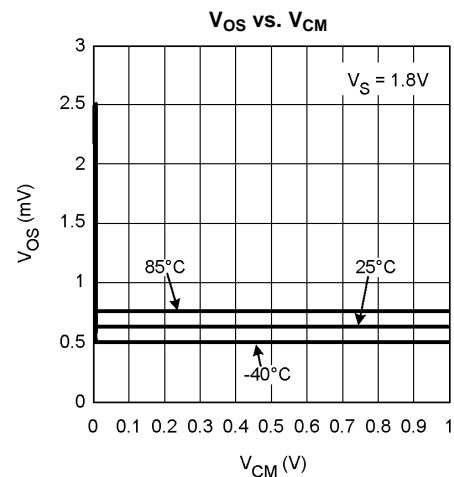

Figure 8.

Typical Performance Characteristics (continued)

Unless otherwise specified, $T_A = 25^\circ\text{C}$.

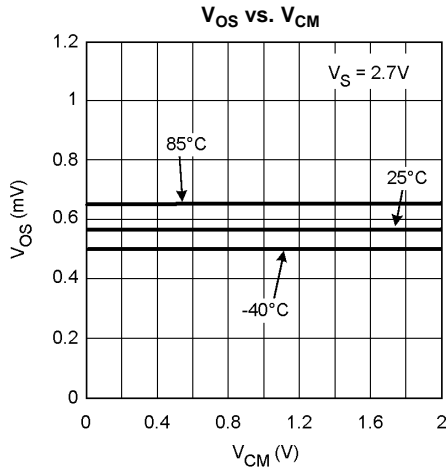

Figure 9.

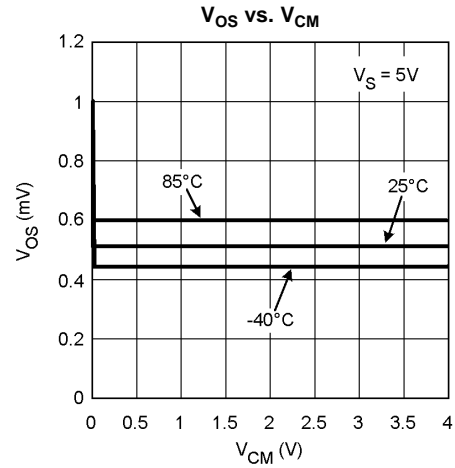

Figure 10.

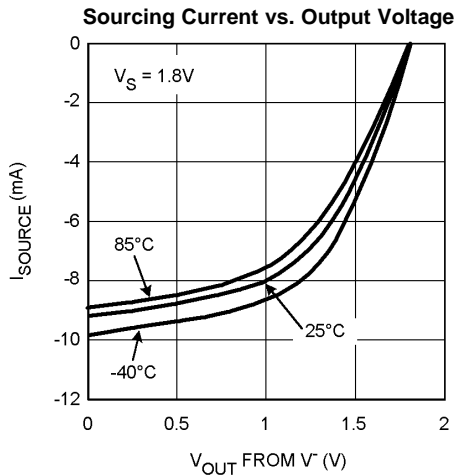

Figure 11.

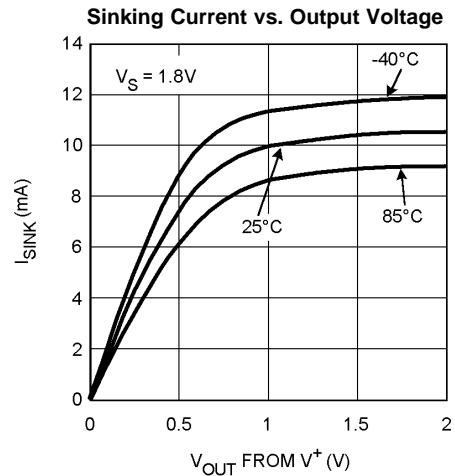

Figure 12.

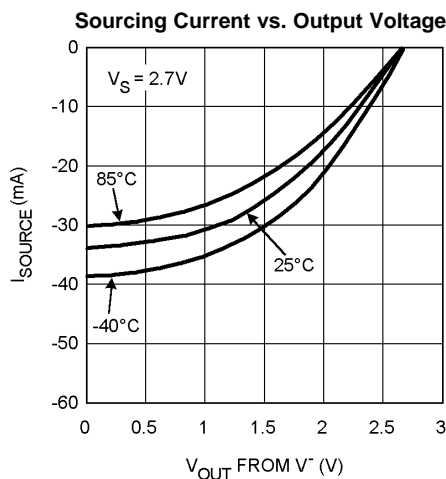

Figure 13.

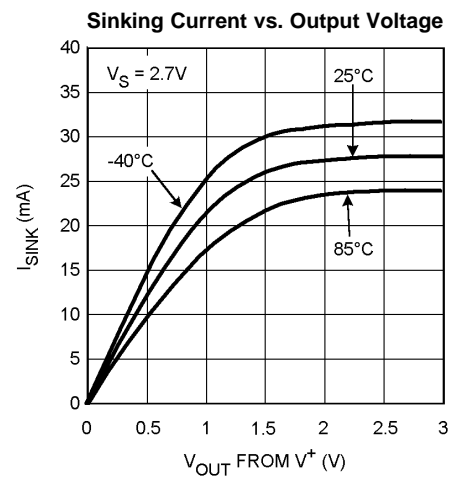

Figure 14.

Typical Performance Characteristics (continued)

Unless otherwise specified, $T_A = 25^\circ\text{C}$.

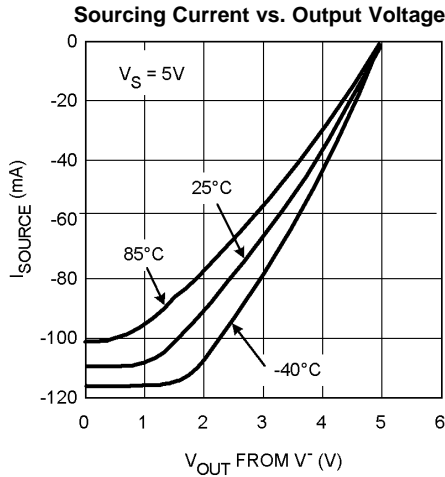

Figure 15.

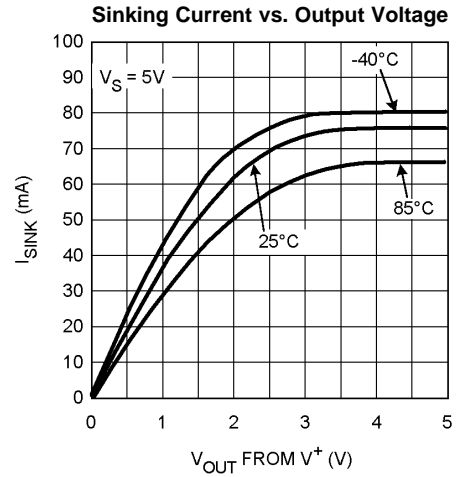

Figure 16.

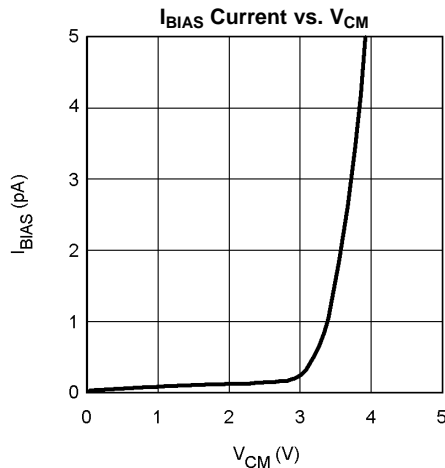

Figure 17.

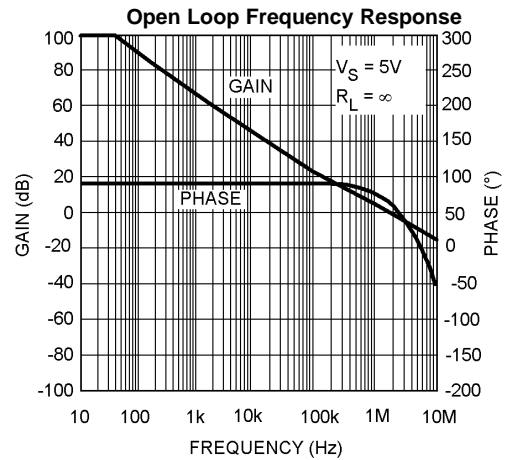

Figure 18.

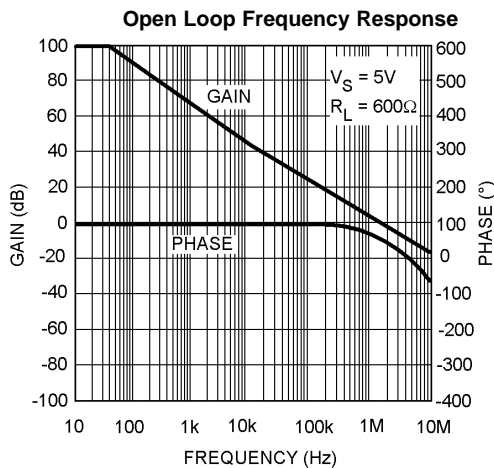

Figure 19.

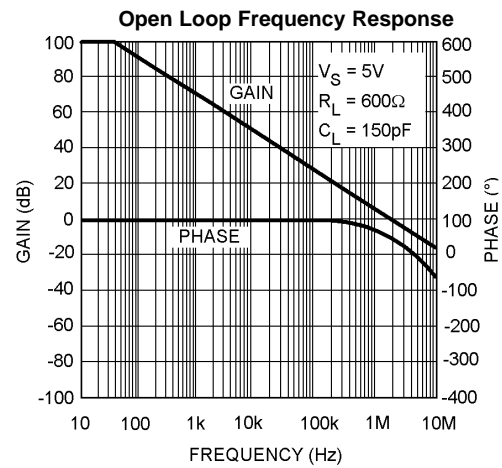

Figure 20.

Typical Performance Characteristics (continued)

Unless otherwise specified, $T_A = 25^\circ\text{C}$.

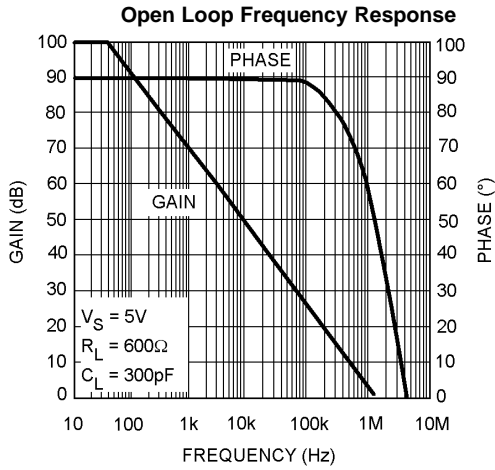

Figure 21.

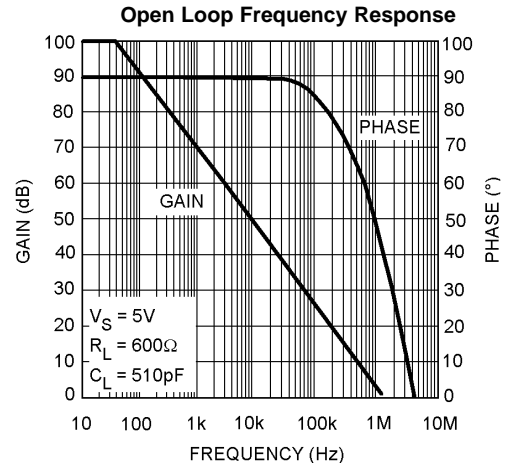

Figure 22.

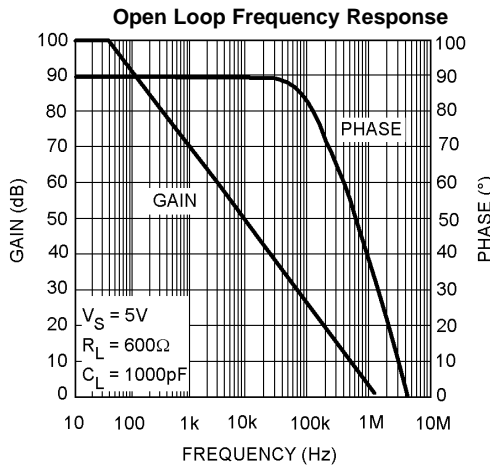

Figure 23.

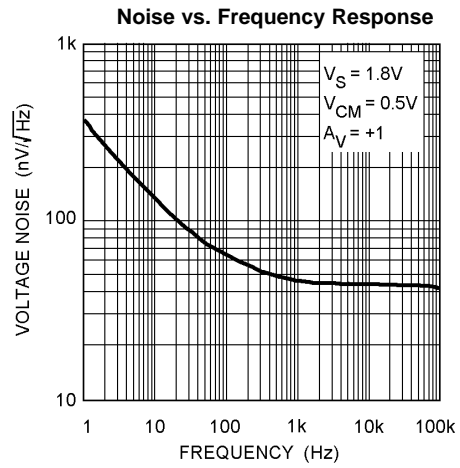

Figure 24.

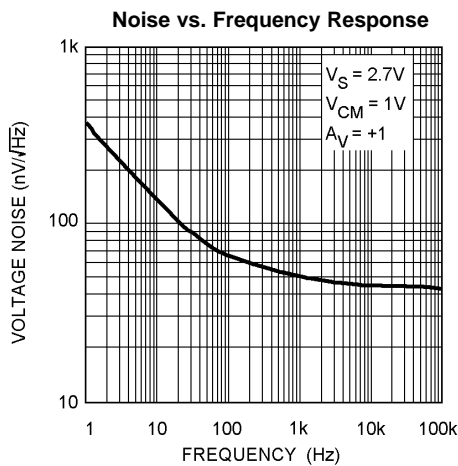

Figure 25.

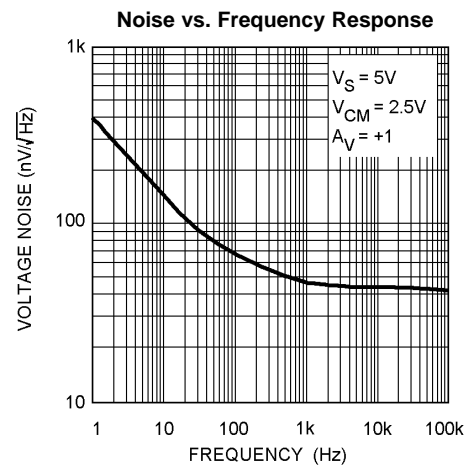

Figure 26.

Typical Performance Characteristics (continued)

Unless otherwise specified, $T_A = 25^\circ\text{C}$.

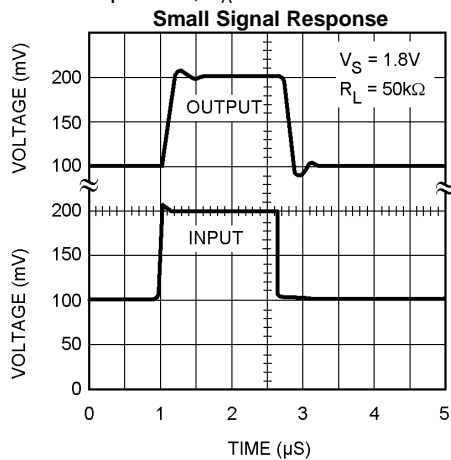

Figure 27.

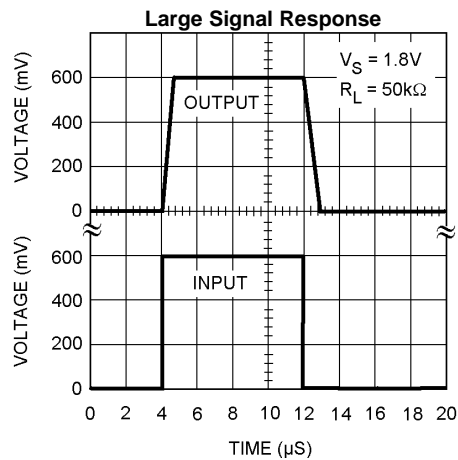

Figure 28.

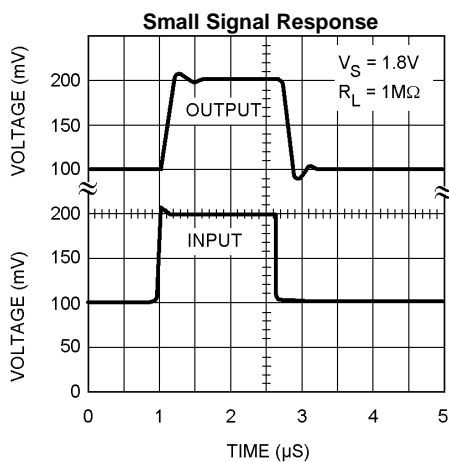

Figure 29.

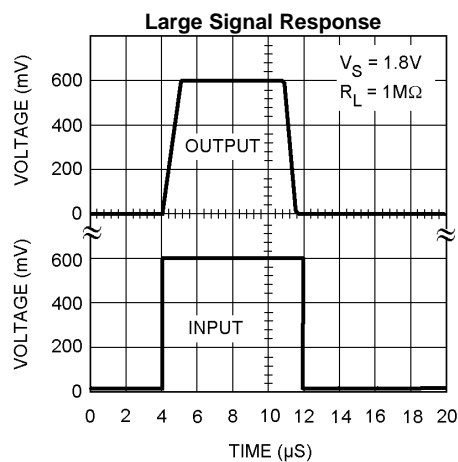

Figure 30.

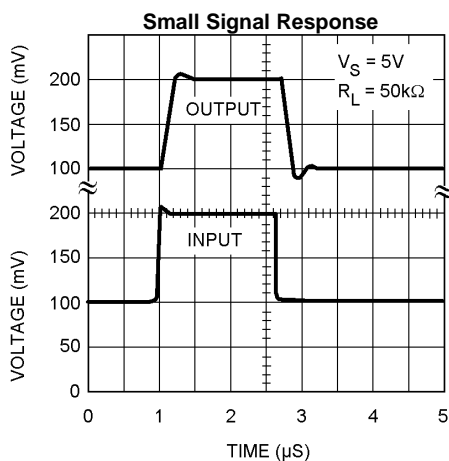

Figure 31.

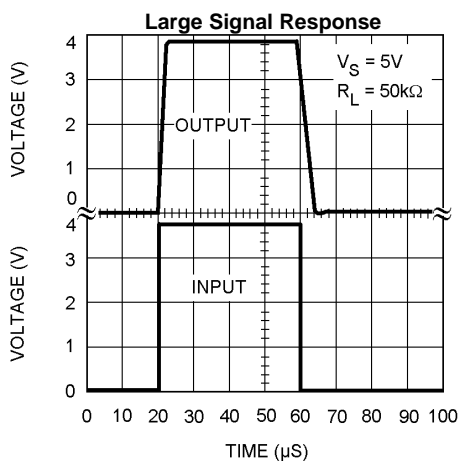

Figure 32.

Typical Performance Characteristics (continued)

Unless otherwise specified, $T_A = 25^\circ\text{C}$.

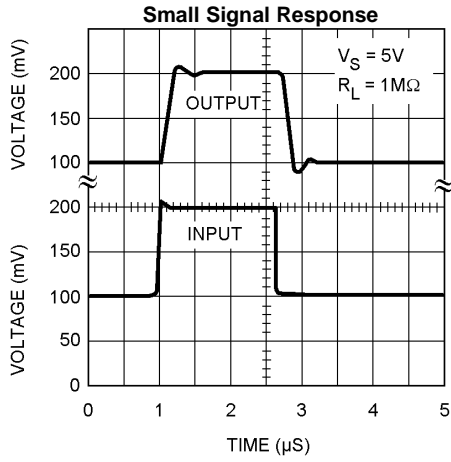

Figure 33.

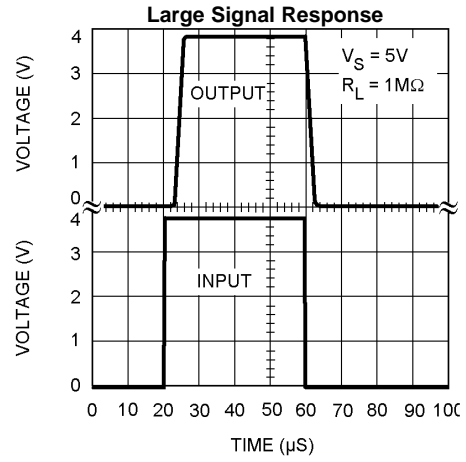

Figure 34.

APPLICATION HINTS

Compensating Input Capacitance

The high input resistance of the LMV301 op amp allows the use of large feedback and source resistor values without losing gain accuracy due to loading. However, the circuit will be especially sensitive to its layout when these large value resistors are used.

Every amplifier has some capacitance between each input and AC ground, and also some differential capacitance between the inputs. When the feedback network around an amplifier is resistive, this input capacitance (along with any additional capacitance due to circuit board traces, the socket, etc.) and the feedback resistors create a pole in the feedback path. In the following General Operational Amplifier circuit, [Figure 35](#), the frequency of this pole is

$$f_p = \frac{1}{2\pi C_S R_P}$$

where

- C_S is the total capacitance at the inverting input, including amplifier input capacitance and any stray capacitance from the IC socket (if one is used), circuit board traces, etc.,
 - R_P is the parallel combination of R_F and R_{IN}
- (1)

This formula, as well as all formulae derived below, apply to inverting and non-inverting op amp configurations.

When the feedback resistors are smaller than a few k Ω , the frequency of the feedback pole will be quite high, since C_S is generally less than 10pF. If the frequency of the feedback pole is much higher than the “ideal” closed-loop bandwidth (the nominal closed-loop bandwidth in the absence of C_S), the pole will have a negligible effect on stability, as it will add only a small amount of phase shift.

However, if the feedback pole is less than approximately 6 to 10 times the “ideal” –3dB frequency, a feedback capacitor, C_F , should be connected between the output and the inverting input of the op amp. This condition can also be stated in terms of the amplifier's low frequency noise gain. To maintain stability a feedback capacitor will probably be needed if

$$\left(\frac{R_F}{R_{IN}} + 1\right) \leq \sqrt{6 \times 2\pi \times \text{GBW} \times R_F \times C_S}$$
(2)

Where

$$\left(\frac{R_F}{R_{IN}} + 1\right)$$
(3)

is the amplifier's low frequency noise gain and GBW is the amplifier's gain bandwidth product.

An amplifier's low frequency noise gain is represented by the formula

$$\left(\frac{R_F}{R_{IN}} + 1\right)$$
(4)

regardless of whether the amplifier is being used in inverting or non-inverting mode. Note that a feedback capacitor is more likely to be needed when the noise gain is low and/or the feedback resistor is large.

If the above condition is met (indicating a feedback capacitor will probably be needed), and the noise gain is large enough that:

$$\left(\frac{R_F}{R_{IN}} + 1\right) \geq 2\sqrt{\text{GBW} \times R_F \times C_S}$$
(5)

the following value of feedback capacitor is recommended:

$$C_F = \frac{C_S}{2\left(\frac{R_F}{R_{IN}} + 1\right)}$$
(6)

If

$$\left(\frac{R_F}{R_{IN}} + 1 \right) < 2\sqrt{GBW \times R_F \times C_S} \quad (7)$$

the feedback capacitor should be:

$$C_F = \sqrt{\frac{C_S}{GBW \times R_F}} \quad (8)$$

Note that these capacitor values are usually significantly smaller than those given by the older, more conservative formula:

$$C_F = \frac{C_S R_{IN}}{R_F} \quad (9)$$

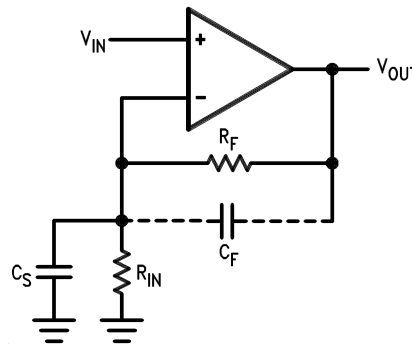

C_S consists of the amplifier's input capacitance plus any stray capacitance from the circuit board and socket. C_F compensates for the pole caused by C_S and the feedback resistors.

Figure 35. General Operational Amplifier Circuit

Using the smaller capacitor will give much higher bandwidth with little degradation of transient response. It may be necessary in any of the above cases to use a somewhat larger feedback capacitor to allow for unexpected stray capacitance, or to tolerate additional phase shifts in the loop, or excessive capacitive load, or to decrease the noise or bandwidth, or simply because the particular circuit implementation needs more feedback capacitance to be sufficiently stable. For example, a printed circuit board's stray capacitance may be larger or smaller than the breadboard's, so the actual optimum value for C_F may be different from the one estimated using the breadboard. In most cases, the values of C_F should be checked on the actual circuit, starting with the computed value.

Capacitive Load Tolerance

Like many other op amps, the LMV301 may oscillate when its applied load appears capacitive. The threshold of oscillation varies both with load and circuit gain. The configuration most sensitive to oscillation is a unity gain follower. The load capacitance interacts with the op amp's output resistance to create an additional pole. If this pole frequency is sufficiently low, it will degrade the op amp's phase margin so that the amplifier is no longer stable. As shown in [Figure 36](#), the addition of a small resistor (50Ω to 100Ω) in series with the op amp's output, and a capacitor (5pF to 10pF) from inverting input to output pins, returns the phase margin to a safe value without interfering with lower frequency circuit operation. Thus, larger values of capacitance can be tolerated without oscillation. Note that in all cases, the output will ring heavily when the load capacitance is near the threshold for oscillation.

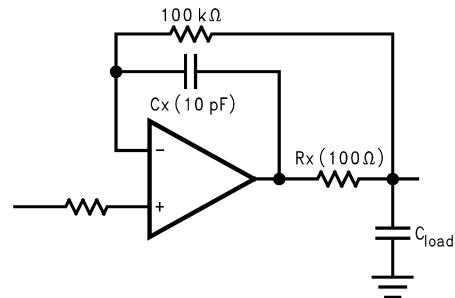

Figure 36. Rx, Cx Improve Capacitive Load Tolerance

Capacitive load driving capability is enhanced by using a pull up resistor to V^+ (Figure 37). Typically a pull up resistor conducting $500\mu\text{A}$ or more will significantly improve capacitive load responses. The value of the pull up resistor must be determined based on the current sinking capability of the amplifier with respect to the desired output swing. Open loop gain of the amplifier can also be affected by the pull up resistor.

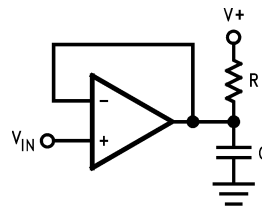

Figure 37. Compensating for Large Capacitive Loads with a Pull Up Resistor

PRINTED-CIRCUIT-BOARD LAYOUT FOR HIGH-IMPEDANCE WORK

It is generally recognized that any circuit which must operate with less than 100pA of leakage current requires special layout of the PC board. When one wishes to take advantage of the low bias current of the LMV301, typically less than 0.182pA , it is essential to have an excellent layout. Fortunately, the techniques for obtaining low leakages are quite simple. First, the user must not ignore the surface leakage of the PC board, even though it may sometimes appear acceptable low, because under conditions of the high humidity or dust or contamination, the surface leakage will be appreciable. To minimize the effect of any surface leakage, lay out a ring of foil completely surrounding the LMV301's inputs and the terminals of capacitors, diodes, conductors, resistors, relay terminals, etc. connected to the op amp's inputs. See Figure 38. To have a significant effect, guard rings should be placed on both the top and bottom of the PC board. The PC foil must then be connected to a voltage which is at the same voltage as the amplifier inputs, since no leakage current can flow between two points at the same potential. For example, a PC board trace-to-pad resistance of $10^{12}\Omega$, which is normally considered a very large resistance, could leak 5pA if the trace were a 5V bus adjacent to the pad of an input. This would cause a 100 times degradation from the LMV301's actual performance. However, if a guard ring is held within 5mV of the inputs, then even a resistance of $10^{11}\Omega$ would cause only 0.05pA of leakage current, or perhaps a minor (2:1) degradation of the amplifier performance. See Figure 39, Figure 40, and Figure 41 for typical connections of guard rings for standard op amp configurations. If both inputs are active and at high impedance, the guard can be tied to ground and still provide some protection; see Figure 42.

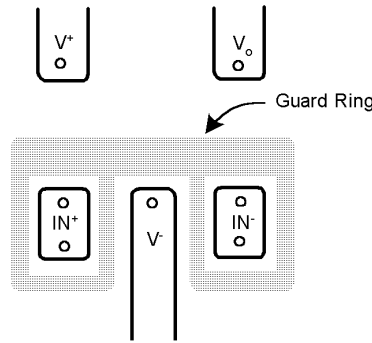

Figure 38. Example, using the LMV301, of Guard Ring in P.C. Board Layout

Guard Ring Connections

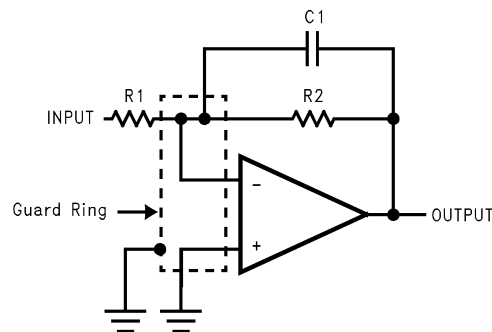

Figure 39. Inverting Amplifier

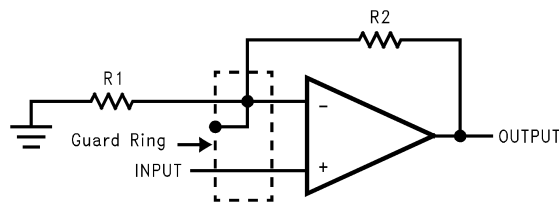

Figure 40. Non-Inverting Amplifier

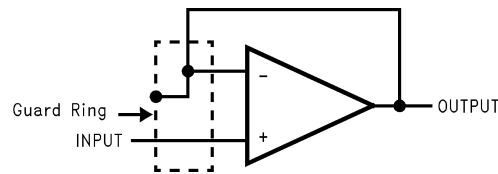

Figure 41. Follower

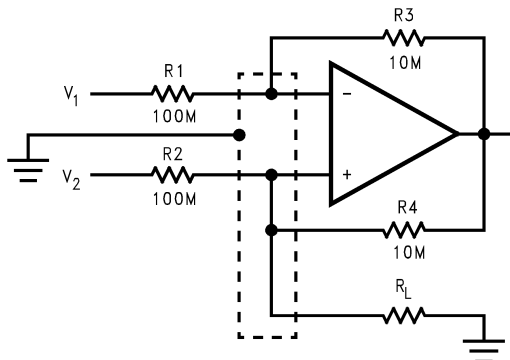
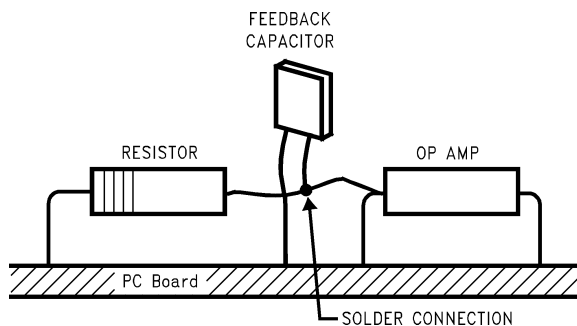

Figure 42. Howland Current Pump

The designer should be aware that when it is inappropriate to lay out a PC board for the sake of just a few circuits, there is another technique which is even better than a guard ring on a PC board: Don't insert the amplifier's input pin into the board at all, but bend it up in the air and use only air as an insulator. Air is an excellent insulator. In this case you may have to forego some of the advantages of PC board construction, but the advantages are sometimes well worth the effort of using point-to-point up-in-the-air wiring. See [Figure 43](#).



(Input pins are lifted out of PC board and soldered directly to components. All other pins connected to PC board.)

Figure 43. Air Wiring

Typical Single-Supply Applications

($V_+ = 5.0$ VDC)

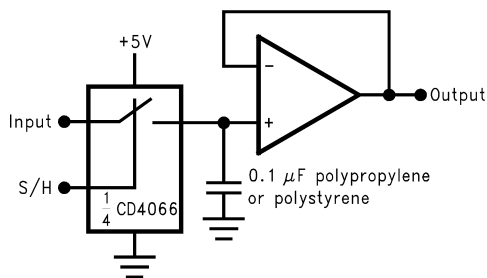

Figure 44. Low-Leakage Sample-and-Hold

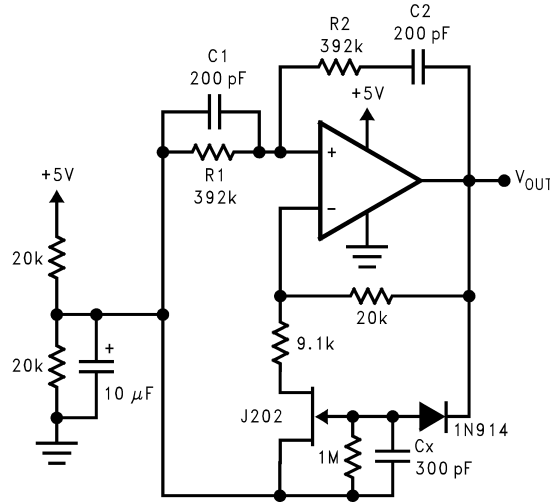

Figure 45. Sine-Wave Oscillator

Oscillator frequency is determined by R1, R2, C1, and C2:

$$f_{osc} = 1/2\pi RC$$

where

- R = R1 = R2
- C = C1 = C2

(10)

This circuit, as shown, oscillates at 2.0kHz with a peak-to-peak output swing of 4.5V.

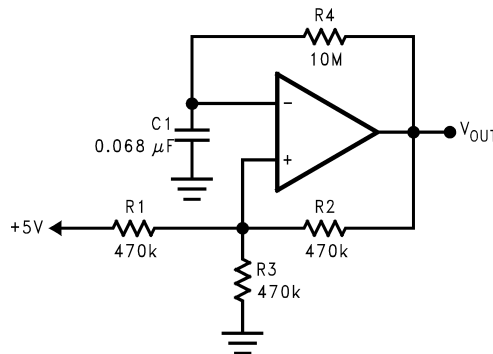

Figure 46. 1 Hz Square-Wave Oscillator

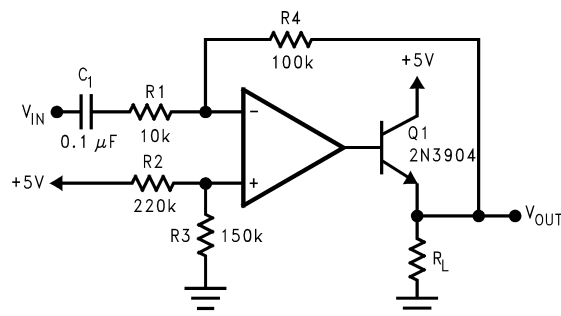
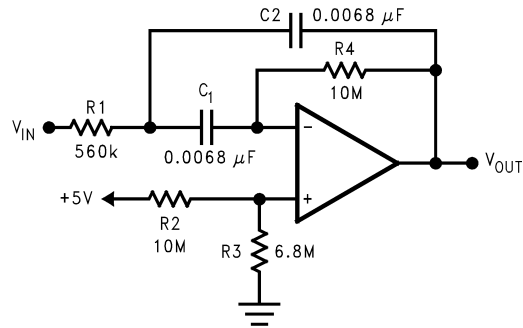
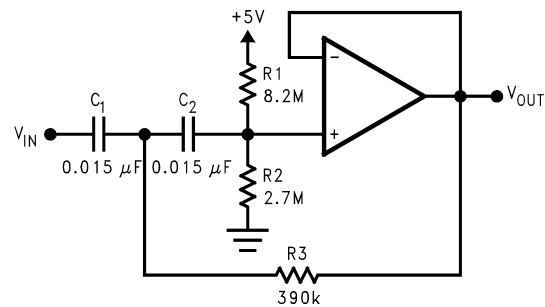

Figure 47. Power Amplifier



$f_0 = 10 \text{ Hz}$
 $Q = 2.1$
 Gain = -8.8

Figure 48. 10Hz Bandpass Filter



$f_c = 10 \text{ Hz}$
 $d = 0.895$
 Gain = 1
 2 dB passband ripple

Figure 49. 10 Hz High-Pass Filter

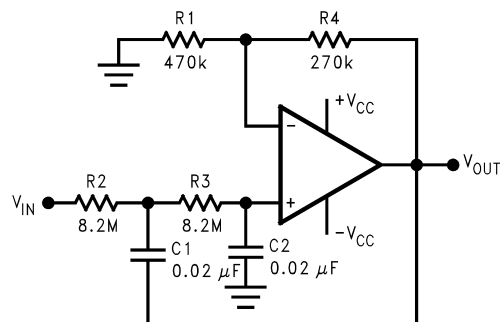

$f_c = 1 \text{ Hz}$
 $d = 1.414$
 Gain = 1.57

Figure 50. 1 Hz Low-Pass Filter
 (Maximally Flat, Dual Supply Only)

REVISION HISTORY

Changes from Original (May 2013) to Revision A	Page
• Changed layout of National Data Sheet to TI format	19

PACKAGING INFORMATION

Orderable Device	Status (1)	Package Type	Package Drawing	Pins	Package Qty	Eco Plan (2)	Lead/Ball Finish (6)	MSL Peak Temp (3)	Op Temp (°C)	Device Marking (4/5)	Samples
LMV301MG/NOPB	ACTIVE	SC70	DCK	5	1000	Green (RoHS & no Sb/Br)	CU SN	Level-1-260C-UNLIM	-40 to 85	A48	Samples
LMV301MGX/NOPB	ACTIVE	SC70	DCK	5	3000	Green (RoHS & no Sb/Br)	CU SN	Level-1-260C-UNLIM	-40 to 85	A48	Samples

(1) The marketing status values are defined as follows:

ACTIVE: Product device recommended for new designs.

LIFEBUY: TI has announced that the device will be discontinued, and a lifetime-buy period is in effect.

NRND: Not recommended for new designs. Device is in production to support existing customers, but TI does not recommend using this part in a new design.

PREVIEW: Device has been announced but is not in production. Samples may or may not be available.

OBSOLETE: TI has discontinued the production of the device.

(2) Eco Plan - The planned eco-friendly classification: Pb-Free (RoHS), Pb-Free (RoHS Exempt), or Green (RoHS & no Sb/Br) - please check <http://www.ti.com/productcontent> for the latest availability information and additional product content details.

TBD: The Pb-Free/Green conversion plan has not been defined.

Pb-Free (RoHS): TI's terms "Lead-Free" or "Pb-Free" mean semiconductor products that are compatible with the current RoHS requirements for all 6 substances, including the requirement that lead not exceed 0.1% by weight in homogeneous materials. Where designed to be soldered at high temperatures, TI Pb-Free products are suitable for use in specified lead-free processes.

Pb-Free (RoHS Exempt): This component has a RoHS exemption for either 1) lead-based flip-chip solder bumps used between the die and package, or 2) lead-based die adhesive used between the die and leadframe. The component is otherwise considered Pb-Free (RoHS compatible) as defined above.

Green (RoHS & no Sb/Br): TI defines "Green" to mean Pb-Free (RoHS compatible), and free of Bromine (Br) and Antimony (Sb) based flame retardants (Br or Sb do not exceed 0.1% by weight in homogeneous material)

(3) MSL, Peak Temp. - The Moisture Sensitivity Level rating according to the JEDEC industry standard classifications, and peak solder temperature.

(4) There may be additional marking, which relates to the logo, the lot trace code information, or the environmental category on the device.

(5) Multiple Device Markings will be inside parentheses. Only one Device Marking contained in parentheses and separated by a "~" will appear on a device. If a line is indented then it is a continuation of the previous line and the two combined represent the entire Device Marking for that device.

(6) Lead/Ball Finish - Orderable Devices may have multiple material finish options. Finish options are separated by a vertical ruled line. Lead/Ball Finish values may wrap to two lines if the finish value exceeds the maximum column width.

Important Information and Disclaimer: The information provided on this page represents TI's knowledge and belief as of the date that it is provided. TI bases its knowledge and belief on information provided by third parties, and makes no representation or warranty as to the accuracy of such information. Efforts are underway to better integrate information from third parties. TI has taken and continues to take reasonable steps to provide representative and accurate information but may not have conducted destructive testing or chemical analysis on incoming materials and chemicals. TI and TI suppliers consider certain information to be proprietary, and thus CAS numbers and other limited information may not be available for release.

In no event shall TI's liability arising out of such information exceed the total purchase price of the TI part(s) at issue in this document sold by TI to Customer on an annual basis.

TAPE AND REEL INFORMATION



QUADRANT ASSIGNMENTS FOR PIN 1 ORIENTATION IN TAPE



*All dimensions are nominal

Device	Package Type	Package Drawing	Pins	SPQ	Reel Diameter (mm)	Reel Width W1 (mm)	A0 (mm)	B0 (mm)	K0 (mm)	P1 (mm)	W (mm)	Pin1 Quadrant
LMV301MG/NOPB	SC70	DCK	5	1000	178.0	8.4	2.25	2.45	1.2	4.0	8.0	Q3
LMV301MGX/NOPB	SC70	DCK	5	3000	178.0	8.4	2.25	2.45	1.2	4.0	8.0	Q3

TAPE AND REEL BOX DIMENSIONS

*All dimensions are nominal

Device	Package Type	Package Drawing	Pins	SPQ	Length (mm)	Width (mm)	Height (mm)
LMV301MG/NOPB	SC70	DCK	5	1000	210.0	185.0	35.0
LMV301MGX/NOPB	SC70	DCK	5	3000	210.0	185.0	35.0

DCK (R-PDSO-G5)

PLASTIC SMALL-OUTLINE PACKAGE



- NOTES:
- A. All linear dimensions are in millimeters.
 - B. This drawing is subject to change without notice.
 - C. Body dimensions do not include mold flash or protrusion. Mold flash and protrusion shall not exceed 0.15 per side.
 - D. Falls within JEDEC MO-203 variation AA.

DCK (R-PDSO-G5)

PLASTIC SMALL OUTLINE

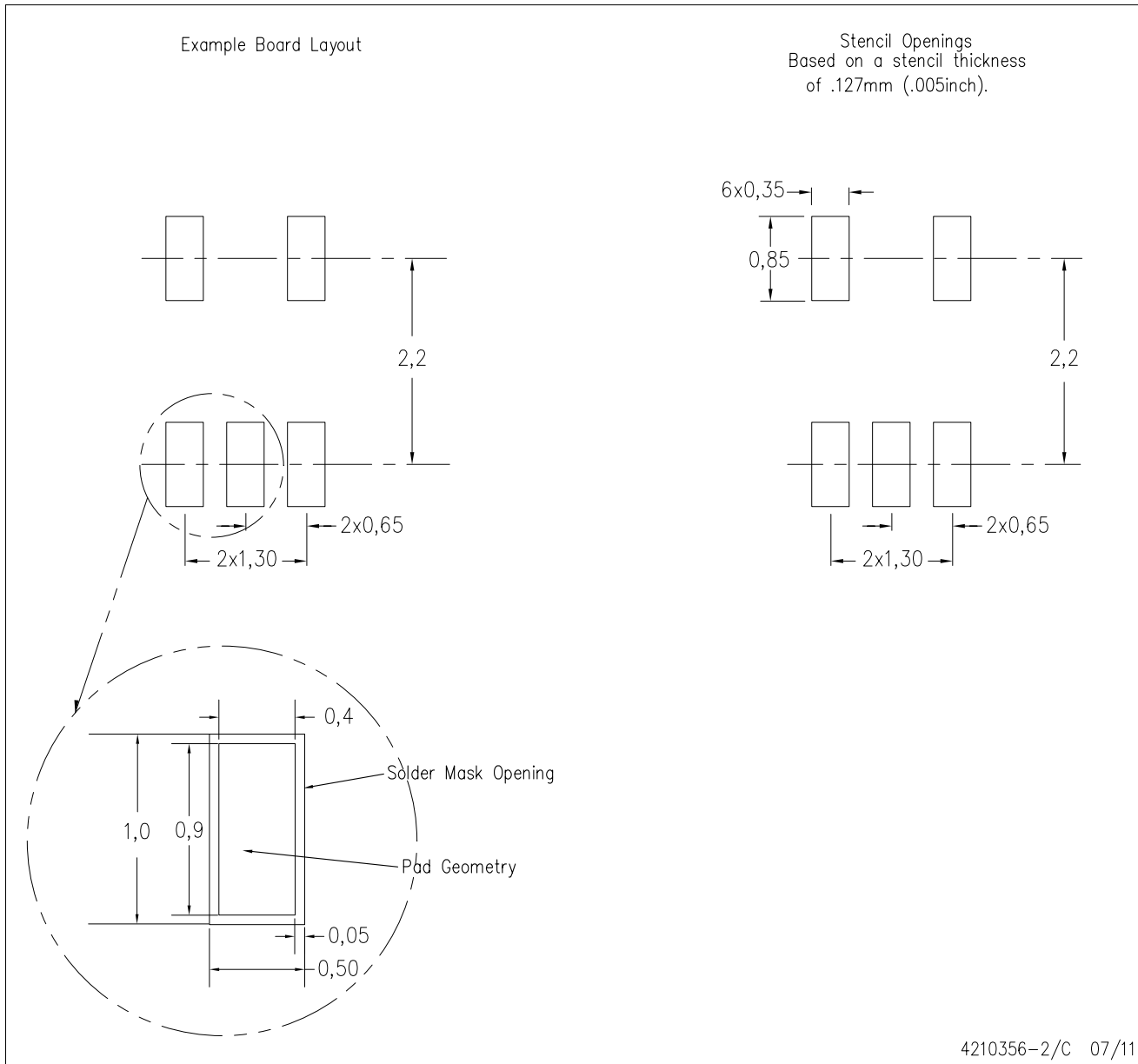

- NOTES:
- All linear dimensions are in millimeters.
 - This drawing is subject to change without notice.
 - Customers should place a note on the circuit board fabrication drawing not to alter the center solder mask defined pad.
 - Publication IPC-7351 is recommended for alternate designs.
 - Laser cutting apertures with trapezoidal walls and also rounding corners will offer better paste release. Customers should contact their board assembly site for stencil design recommendations. Example stencil design based on a 50% volumetric metal load solder paste. Refer to IPC-7525 for other stencil recommendations.

IMPORTANT NOTICE

Texas Instruments Incorporated (TI) reserves the right to make corrections, enhancements, improvements and other changes to its semiconductor products and services per JESD46, latest issue, and to discontinue any product or service per JESD48, latest issue. Buyers should obtain the latest relevant information before placing orders and should verify that such information is current and complete.

TI's published terms of sale for semiconductor products (<http://www.ti.com/sc/docs/stdterms.htm>) apply to the sale of packaged integrated circuit products that TI has qualified and released to market. Additional terms may apply to the use or sale of other types of TI products and services.

Reproduction of significant portions of TI information in TI data sheets is permissible only if reproduction is without alteration and is accompanied by all associated warranties, conditions, limitations, and notices. TI is not responsible or liable for such reproduced documentation. Information of third parties may be subject to additional restrictions. Resale of TI products or services with statements different from or beyond the parameters stated by TI for that product or service voids all express and any implied warranties for the associated TI product or service and is an unfair and deceptive business practice. TI is not responsible or liable for any such statements.

Buyers and others who are developing systems that incorporate TI products (collectively, "Designers") understand and agree that Designers remain responsible for using their independent analysis, evaluation and judgment in designing their applications and that Designers have full and exclusive responsibility to assure the safety of Designers' applications and compliance of their applications (and of all TI products used in or for Designers' applications) with all applicable regulations, laws and other applicable requirements. Designer represents that, with respect to their applications, Designer has all the necessary expertise to create and implement safeguards that (1) anticipate dangerous consequences of failures, (2) monitor failures and their consequences, and (3) lessen the likelihood of failures that might cause harm and take appropriate actions. Designer agrees that prior to using or distributing any applications that include TI products, Designer will thoroughly test such applications and the functionality of such TI products as used in such applications.

TI's provision of technical, application or other design advice, quality characterization, reliability data or other services or information, including, but not limited to, reference designs and materials relating to evaluation modules, (collectively, "TI Resources") are intended to assist designers who are developing applications that incorporate TI products; by downloading, accessing or using TI Resources in any way, Designer (individually or, if Designer is acting on behalf of a company, Designer's company) agrees to use any particular TI Resource solely for this purpose and subject to the terms of this Notice.

TI's provision of TI Resources does not expand or otherwise alter TI's applicable published warranties or warranty disclaimers for TI products, and no additional obligations or liabilities arise from TI providing such TI Resources. TI reserves the right to make corrections, enhancements, improvements and other changes to its TI Resources. TI has not conducted any testing other than that specifically described in the published documentation for a particular TI Resource.

Designer is authorized to use, copy and modify any individual TI Resource only in connection with the development of applications that include the TI product(s) identified in such TI Resource. NO OTHER LICENSE, EXPRESS OR IMPLIED, BY ESTOPPEL OR OTHERWISE TO ANY OTHER TI INTELLECTUAL PROPERTY RIGHT, AND NO LICENSE TO ANY TECHNOLOGY OR INTELLECTUAL PROPERTY RIGHT OF TI OR ANY THIRD PARTY IS GRANTED HEREIN, including but not limited to any patent right, copyright, mask work right, or other intellectual property right relating to any combination, machine, or process in which TI products or services are used. Information regarding or referencing third-party products or services does not constitute a license to use such products or services, or a warranty or endorsement thereof. Use of TI Resources may require a license from a third party under the patents or other intellectual property of the third party, or a license from TI under the patents or other intellectual property of TI.

TI RESOURCES ARE PROVIDED "AS IS" AND WITH ALL FAULTS. TI DISCLAIMS ALL OTHER WARRANTIES OR REPRESENTATIONS, EXPRESS OR IMPLIED, REGARDING RESOURCES OR USE THEREOF, INCLUDING BUT NOT LIMITED TO ACCURACY OR COMPLETENESS, TITLE, ANY EPIDEMIC FAILURE WARRANTY AND ANY IMPLIED WARRANTIES OF MERCHANTABILITY, FITNESS FOR A PARTICULAR PURPOSE, AND NON-INFRINGEMENT OF ANY THIRD PARTY INTELLECTUAL PROPERTY RIGHTS. TI SHALL NOT BE LIABLE FOR AND SHALL NOT DEFEND OR INDEMNIFY DESIGNER AGAINST ANY CLAIM, INCLUDING BUT NOT LIMITED TO ANY INFRINGEMENT CLAIM THAT RELATES TO OR IS BASED ON ANY COMBINATION OF PRODUCTS EVEN IF DESCRIBED IN TI RESOURCES OR OTHERWISE. IN NO EVENT SHALL TI BE LIABLE FOR ANY ACTUAL, DIRECT, SPECIAL, COLLATERAL, INDIRECT, PUNITIVE, INCIDENTAL, CONSEQUENTIAL OR EXEMPLARY DAMAGES IN CONNECTION WITH OR ARISING OUT OF TI RESOURCES OR USE THEREOF, AND REGARDLESS OF WHETHER TI HAS BEEN ADVISED OF THE POSSIBILITY OF SUCH DAMAGES.

Unless TI has explicitly designated an individual product as meeting the requirements of a particular industry standard (e.g., ISO/TS 16949 and ISO 26262), TI is not responsible for any failure to meet such industry standard requirements.

Where TI specifically promotes products as facilitating functional safety or as compliant with industry functional safety standards, such products are intended to help enable customers to design and create their own applications that meet applicable functional safety standards and requirements. Using products in an application does not by itself establish any safety features in the application. Designers must ensure compliance with safety-related requirements and standards applicable to their applications. Designer may not use any TI products in life-critical medical equipment unless authorized officers of the parties have executed a special contract specifically governing such use. Life-critical medical equipment is medical equipment where failure of such equipment would cause serious bodily injury or death (e.g., life support, pacemakers, defibrillators, heart pumps, neurostimulators, and implantables). Such equipment includes, without limitation, all medical devices identified by the U.S. Food and Drug Administration as Class III devices and equivalent classifications outside the U.S.

TI may expressly designate certain products as completing a particular qualification (e.g., Q100, Military Grade, or Enhanced Product). Designers agree that it has the necessary expertise to select the product with the appropriate qualification designation for their applications and that proper product selection is at Designers' own risk. Designers are solely responsible for compliance with all legal and regulatory requirements in connection with such selection.

Designer will fully indemnify TI and its representatives against any damages, costs, losses, and/or liabilities arising out of Designer's non-compliance with the terms and provisions of this Notice.

Looking for pricing, stock, or lifecycle information?

Click below to explore more details on WIN SOURCE:

 [View LMV301MGX/NOPB on WIN SOURCE](#)

 [Texas Instruments](#) Information

Optimize Your Supply Chain with WIN SOURCE Solutions

-  Global Sourcing Solution
-  Obsolete Management
-  Cost Control Management
-  Shortage Management
-  Alternative Solution
-  Excess Inventory Management