



**THE DATASHEET OF  
LMV331M7X/NOPB**



## LMV33x-N / LMV393-N General-Purpose, Low-Voltage, Tiny Pack Comparators

### 1 Features

- (For 5-V Supply, Typical Unless Otherwise Noted)
- Ensured 2.7-V and 5-V Performance
- Industrial Temperature Range  $-40^{\circ}\text{C}$  to  $85^{\circ}\text{C}$
- Low Supply Current 60  $\mu\text{A}/\text{Channel}$
- Input Common Mode Voltage Range Includes Ground
- Low Output Saturation Voltage 200 mV
- Propagation Delay 200 ns
- Space-Saving 5-Pin SC70 and 5-Pin SOT23 Packages

### 2 Applications

- Mobile Communications
- Notebooks and PDAs
- Battery-Powered Electronics
- General-Purpose Portable Devices
- General-Purpose, Low-Voltage Applications

### 3 Description

The LMV393-N and LMV339-N are low-voltage (2.7 to 5 V) versions of the dual and quad comparators, LM393/339, which are specified at 5 to 30 V. The LMV331-N is the single version, which is available in space-saving, 5-pin SC70 and 5-pin SOT23 packages. The 5-pin SC70 is approximately half the size of the 5-pin SOT23.

The LMV393-N is available in 8-pin SOIC and VSSOP packages. The LMV339-N is available in 14-pin SOIC and TSSOP packages.

The LMV331-N/393-N/339-N is the most cost-effective solution where space, low voltage, low power, and price are the primary specification in circuit design for portable consumer products. They offer specifications that meet or exceed the familiar LM393/339 at a fraction of the supply current.

The chips are built with TI's advanced Submicron Silicon-Gate BiCMOS process. The LMV331-N/393-N/339-N have bipolar input and output stages for improved noise performance.

**Table 1. Device Information<sup>(1)</sup>**

PART NUMBER	PACKAGE	BODY SIZE (NOM)
LMV331-N	SC70 (5)	2.00 mm x 1.25 mm
	SOT-23 (5)	2.90 mm x 1.6 mm
LMV339-N	SOIC (14)	8.65 mm x 3.91 mm
	TSSOP (14)	5.00 mm x 4.40 mm
LMV393-N	SOIC (8)	4.90 mm x 3.91 mm
	VSSOP (8)	3.00 mm x 3.00 mm

(1) For all available packages, see the orderable addendum at the end of the datasheet.

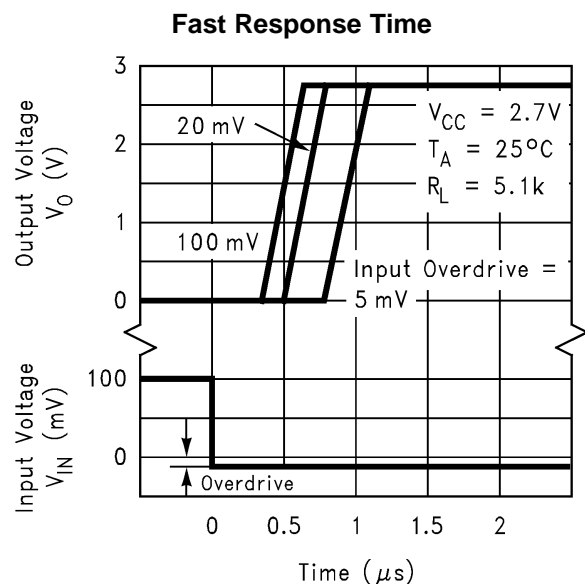
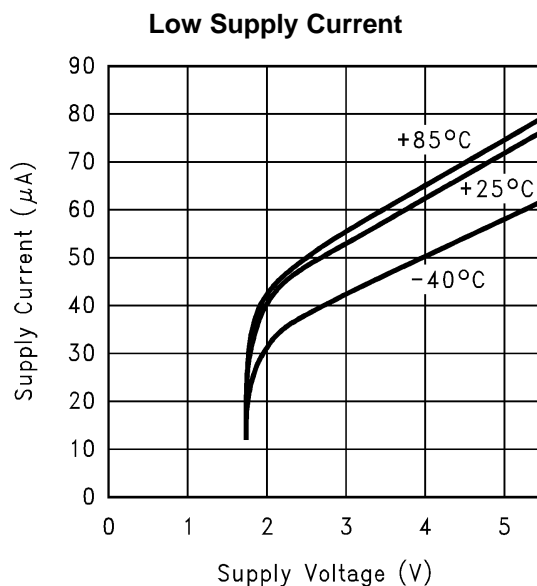

## Table of Contents

<b>1 Features</b> .....	<b>1</b>	7.3 Feature Description .....	<b>9</b>
<b>2 Applications</b> .....	<b>1</b>	7.4 Device Functional Modes .....	<b>9</b>
<b>3 Description</b> .....	<b>1</b>	<b>8 Application and Implementation</b> .....	<b>10</b>
<b>4 Revision History</b> .....	<b>2</b>	8.1 Application Information .....	<b>10</b>
<b>5 Pin Configuration and Functions</b> .....	<b>3</b>	8.2 Typical Applications .....	<b>16</b>
<b>6 Specifications</b> .....	<b>4</b>	<b>9 Power Supply Recommendations</b> .....	<b>21</b>
6.1 Absolute Maximum Ratings .....	<b>4</b>	<b>10 Layout</b> .....	<b>21</b>
6.2 ESD Ratings .....	<b>4</b>	10.1 Layout Guidelines .....	<b>21</b>
6.3 Recommended Operating Conditions .....	<b>4</b>	10.2 Layout Example .....	<b>22</b>
6.4 Thermal Information .....	<b>4</b>	<b>11 Device and Documentation Support</b> .....	<b>23</b>
6.5 2.7-V DC Electrical Characteristics .....	<b>4</b>	11.1 Device Support .....	<b>23</b>
6.6 2.7-V AC Electrical Characteristics .....	<b>5</b>	11.2 Documentation Support .....	<b>23</b>
6.7 5-V DC Electrical Characteristics .....	<b>5</b>	11.3 Related Links .....	<b>23</b>
6.8 5-V AC Electrical Characteristics .....	<b>6</b>	11.4 Trademarks .....	<b>23</b>
6.9 Typical Characteristics .....	<b>7</b>	11.5 Electrostatic Discharge Caution .....	<b>23</b>
<b>7 Detailed Description</b> .....	<b>9</b>	11.6 Glossary .....	<b>23</b>
7.1 Overview .....	<b>9</b>	<b>12 Mechanical, Packaging, and Orderable Information</b> .....	<b>23</b>
7.2 Functional Block Diagram .....	<b>9</b>		

## 4 Revision History

NOTE: Page numbers for previous revisions may differ from page numbers in the current version.

### Changes from Revision G (February 2013) to Revision H

Page

- Added *Pin Configuration and Functions* section, *ESD Ratings* table, *Feature Description* section, *Device Functional Modes*, *Application and Implementation* section, *Power Supply Recommendations* section, *Layout* section, *Device and Documentation Support* section, and *Mechanical, Packaging, and Orderable Information* section ..... **1**

## 5 Pin Configuration and Functions

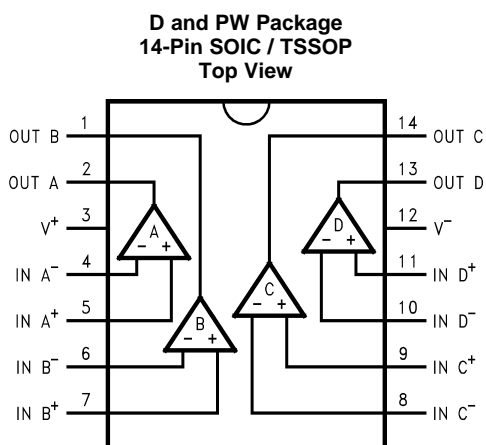
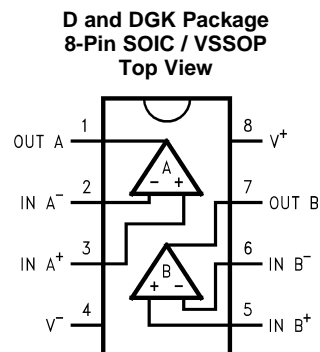
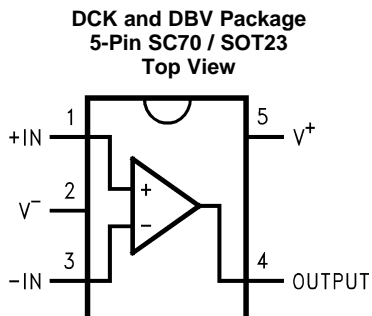

### Pin Functions

NAME	PIN			TYPE	DESCRIPTION
	LMV331-N DVB,DCK	LMV393-N D,DGK	LMV339-N PW		
+IN	1	-	-	I	Noninverting input
+IN A	-	3	5	I	Noninverting input, channel A
+IN B	-	5	7	I	Noninverting input, channel B
+IN C	-	-	9	I	Noninverting input, channel C
+IN D	-	-	11	I	Noninverting input, channel D
-IN	3	-	-	I	Inverting input
-IN A	-	2	4	I	Inverting input, channel A
-IN B	-	6	6	I	Inverting input, channel B
-IN C	-	-	8	I	Inverting input, channel C
-IN D	-	-	10	I	Inverting input, channel D
OUT	4	-	-	O	Output
OUT A	-	1	2	O	Output, channel A
OUT B	-	7	1	O	Output, channel B
OUT C	-	-	14	O	Output, channel C
OUT D	-	-	13	O	Output, channel D
V+	5	8	3	P	Positive (highest) power supply
V-	2	4	12	P	Negative (lowest) power supply

## 6 Specifications

### 6.1 Absolute Maximum Ratings

 over operating free-air temperature range (unless otherwise noted)<sup>(1)(2)</sup>

	MIN	MAX	UNIT
Differential Input Voltage		±Supply Voltage	
Voltage on any pin (referred to V <sup>-</sup> pin)		5.5	V
Soldering Information			
Infrared or Convection (20 sec)		235	°C
Junction Temperature <sup>(3)</sup>		150	°C
Storage temperature, T <sub>stg</sub>	-65	150	°C

- (1) Stresses beyond those listed under *Absolute Maximum Ratings* may cause permanent damage to the device. These are stress ratings only, which do not imply functional operation of the device at these or any other conditions beyond those indicated under *Recommended Operating Conditions*. Exposure to absolute-maximum-rated conditions for extended periods may affect device reliability.
- (2) If Military/Aerospace specified devices are required, please contact the Texas Instruments Sales Office / Distributors for availability and specifications.
- (3) The maximum power dissipation is a function of T<sub>J(MAX)</sub>, θ<sub>JA</sub>. The maximum allowable power dissipation at any ambient temperature is P<sub>D</sub> = (T<sub>J(MAX)</sub> - T<sub>A</sub>)/θ<sub>JA</sub>. All numbers apply for packages soldered directly onto a PC board.

### 6.2 ESD Ratings

		VALUE	UNIT
V <sub>(ESD)</sub> Electrostatic discharge	Human-body model (HBM), per ANSI/ESDA/JEDEC JS-001 <sup>(1)</sup>	±800	V
	Machine model	±120	

- (1) JEDEC document JEP155 states that 500-V HBM allows safe manufacturing with a standard ESD control process.

### 6.3 Recommended Operating Conditions

 over operating free-air temperature range (unless otherwise noted)<sup>(1)</sup>

	MIN	MAX	UNIT
Supply Voltage	2.7	5	V
Temperature Range <sup>(2)</sup>	-40	85	°C

- (1) Stresses beyond those listed under *Absolute Maximum Ratings* may cause permanent damage to the device. These are stress ratings only, which do not imply functional operation of the device at these or any other conditions beyond those indicated under *Recommended Operating Conditions*. Exposure to absolute-maximum-rated conditions for extended periods may affect device reliability.
- (2) The maximum power dissipation is a function of T<sub>J(MAX)</sub>, θ<sub>JA</sub>. The maximum allowable power dissipation at any ambient temperature is P<sub>D</sub> = (T<sub>J(MAX)</sub> - T<sub>A</sub>)/θ<sub>JA</sub>. All numbers apply for packages soldered directly onto a PC board.

### 6.4 Thermal Information

THERMAL METRIC <sup>(1)</sup>	LMV331-N		LMV339-N		LMV393-N		UNIT
	DCK	DBV	D	PW	D	DGK	
	5 PINS	5 PINS	14 PINS	14 PINS	8 PINS	8 PINS	
R <sub>θJA</sub> Junction-to-ambient thermal resistance	478	265	145	155	190	23	°C/W

- (1) For more information about traditional and new thermal metrics, see the *IC Package Thermal Metrics* application report, [SPRA953](#).

### 6.5 2.7-V DC Electrical Characteristics

 Unless otherwise specified, all limits ensured for T<sub>J</sub> = 25°C, V<sup>+</sup> = 2.7V, V<sup>-</sup> = 0V.

PARAMETER	TEST CONDITIONS	MIN <sup>(1)</sup>	TYP <sup>(2)</sup>	MAX <sup>(1)</sup>	UNIT
V <sub>OS</sub> Input Offset Voltage			1.7	7	mV
TCV <sub>OS</sub> Input Offset Voltage Average Drift	At the temperature extremes		5		µV/°C

- (1) All limits are ensured by testing or statistical analysis.
- (2) Typical values represent the most likely parametric norm as determined at the time of characterization. Actual typical values may vary over time and will also depend on the application and configuration. The typical values are not tested and are not ensured on shipped production material.

## 2.7-V DC Electrical Characteristics (continued)

Unless otherwise specified, all limits ensured for  $T_J = 25^\circ\text{C}$ ,  $V^+ = 2.7\text{V}$ ,  $V^- = 0\text{V}$ .

PARAMETER		TEST CONDITIONS	MIN (1)	TYP (2)	MAX (1)	UNIT
$I_B$	Input Bias Current			10	250	nA
		At the temperature extremes			400	
$I_{OS}$	Input Offset Current			5	50	nA
		At the temperature extremes			150	
$V_{CM}$	Input Voltage Range			-0.1		V
				2.0		V
$V_{SAT}$	Saturation Voltage	$I_{SINK} \leq 1\text{ mA}$		120		mV
$I_O$	Output Sink Current	$V_O \leq 1.5\text{V}$	5	23		mA
$I_S$	Supply Current	LMV331-N		40	100	$\mu\text{A}$
		LMV393-N Both Comparators		70	140	$\mu\text{A}$
		LMV339-N All four Comparators		140	200	$\mu\text{A}$
	Output Leakage Current			.003		$\mu\text{A}$
		At the temperature extremes			1	

## 6.6 2.7-V AC Electrical Characteristics

$T_J = 25^\circ\text{C}$ ,  $V^+ = 2.7\text{ V}$ ,  $R_L = 5.1\text{ k}\Omega$ ,  $V^- = 0\text{ V}$ .

PARAMETER		TEST CONDITIONS	MIN (1)	TYP (2)	MAX (1)	UNIT
$t_{PHL}$	Propagation Delay (High to Low)	Input Overdrive = 10 mV		1000		ns
		Input Overdrive = 100 mV		350		ns
$t_{PLH}$	Propagation Delay (Low to High)	Input Overdrive = 10 mV		500		ns
		Input Overdrive = 100 mV		400		ns

(1) All limits are ensured by testing or statistical analysis.

(2) Typical values represent the most likely parametric norm as determined at the time of characterization. Actual typical values may vary over time and will also depend on the application and configuration. The typical values are not tested and are not ensured on shipped production material.

## 6.7 5-V DC Electrical Characteristics

Unless otherwise specified, all limits ensured for  $T_J = 25^\circ\text{C}$ ,  $V^+ = 5\text{ V}$ ,  $V^- = 0\text{ V}$ .

PARAMETER		TEST CONDITIONS	MIN (1)	TYP (2)	MAX (1)	UNIT
$V_{OS}$	Input Offset Voltage			1.7	7	mV
		At the temperature extremes			9	
$TCV_{OS}$	Input Offset Voltage Average Drift			5		$\mu\text{V}/^\circ\text{C}$
$I_B$	Input Bias Current			25	250	nA
		At the temperature extremes			400	
$I_{OS}$	Input Offset Current			2	50	nA
		At the temperature extremes			150	
$V_{CM}$	Input Voltage Range			-0.1		V
				4.2		V
$A_V$	Voltage Gain		20	50		V/mV

(1) All limits are ensured by testing or statistical analysis.

(2) Typical values represent the most likely parametric norm as determined at the time of characterization. Actual typical values may vary over time and will also depend on the application and configuration. The typical values are not tested and are not ensured on shipped production material.

## 5-V DC Electrical Characteristics (continued)

Unless otherwise specified, all limits ensured for  $T_J = 25^\circ\text{C}$ ,  $V^+ = 5\text{ V}$ ,  $V^- = 0\text{ V}$ .

PARAMETER		TEST CONDITIONS	MIN (1)	TYP (2)	MAX (1)	UNIT
$V_{\text{sat}}$	Saturation Voltage	$I_{\text{SINK}} \leq 4\text{ mA}$		200	400	mV
		At the temperature extremes			700	
$I_{\text{O}}$	Output Sink Current	$V_{\text{O}} \leq 1.5\text{ V}$		84	10	mA
$I_{\text{S}}$	Supply Current	LMV331-N		60	120	$\mu\text{A}$
		At the temperature extremes			150	
		LMV393-N Both Comparators		100	200	$\mu\text{A}$
		At the temperature extremes			250	
		LMV339-N All four Comparators		170	300	$\mu\text{A}$
		At the temperature extremes			350	
	Output Leakage Current			.003		$\mu\text{A}$
		At the temperature extremes			1	

## 6.8 5-V AC Electrical Characteristics

$T_J = 25^\circ\text{C}$ ,  $V^+ = 5\text{ V}$ ,  $R_L = 5.1\text{ k}\Omega$ ,  $V^- = 0\text{ V}$ .

PARAMETER		TEST CONDITIONS	MIN (1)	TYP (2)	MAX (1)	UNIT
$t_{\text{PHL}}$	Propagation Delay (High to Low)	Input Overdrive = 10 mV		600		ns
		Input Overdrive = 100 mV		200		ns
$t_{\text{PLH}}$	Propagation Delay (Low to High)	Input Overdrive = 10 mV		450		ns
		Input Overdrive = 100 mV		300		ns

- (1) All limits are ensured by testing or statistical analysis.
- (2) Typical values represent the most likely parametric norm as determined at the time of characterization. Actual typical values may vary over time and will also depend on the application and configuration. The typical values are not tested and are not ensured on shipped production material.

## 6.9 Typical Characteristics

Unless otherwise specified,  $V_S = +5V$ , single supply,  $T_A = 25^\circ C$

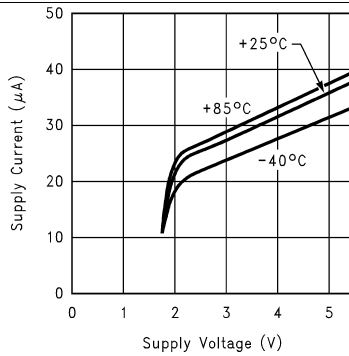

Figure 1. Supply Current vs. Supply Voltage Output High (LMV331-N)

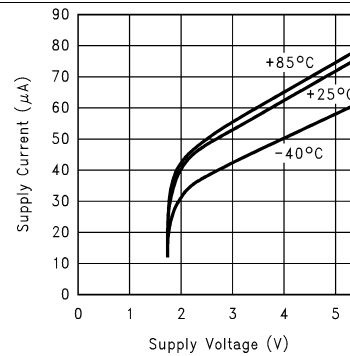

Figure 2. Supply Current vs. Supply Voltage Output Low (LMV331-N)

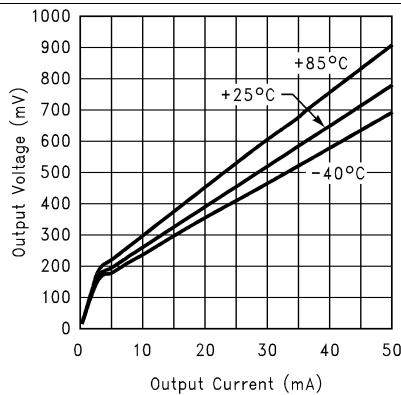

Figure 3. Output Voltage vs. Output Current at 5-V Supply

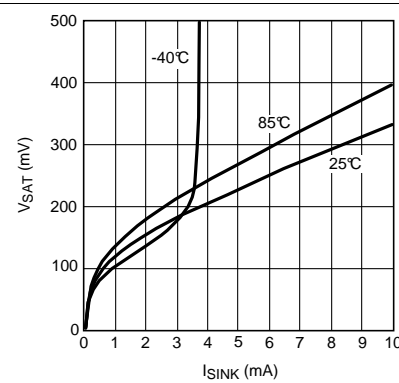

Figure 4. Output Voltage vs. Output Current at 2.7-V Supply

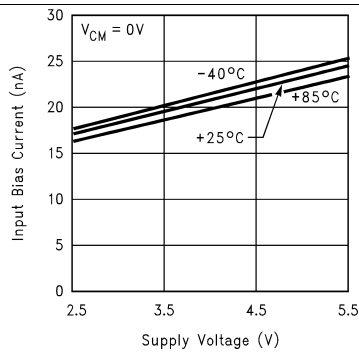

Figure 5. Input Bias Current vs. Supply Voltage

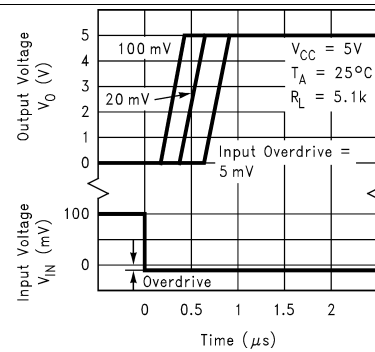
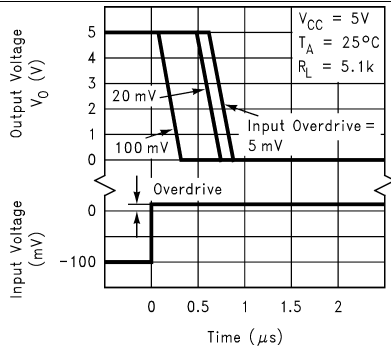

Figure 6. Response Time vs. Input Overdrive Negative Transition

### Typical Characteristics (continued)

Unless otherwise specified,  $V_S = +5V$ , single supply,  $T_A = 25^\circ C$



**Figure 7. Response Time for Input Overdrive Positive Transition**

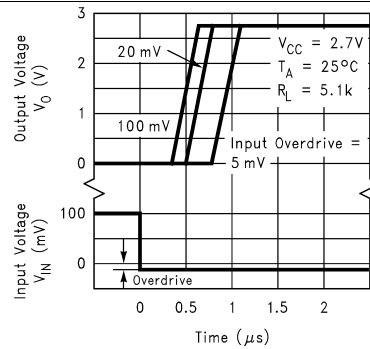

**Figure 8. Response Time vs. Input Overdrive Negative Transition**

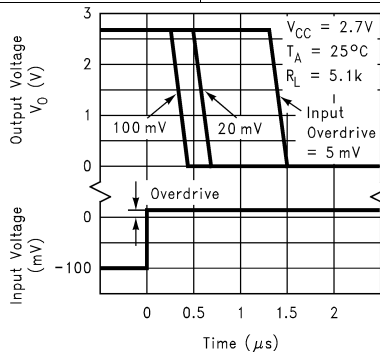

**Figure 9. Response Time for Input Overdrive Positive Transition**

## 7 Detailed Description

### 7.1 Overview

The LMV331-N/393-N/339-N comparators features a supply voltage range of 2.7 V to 5 V with a low supply current of 55  $\mu\text{A}$ /channel with propagation delays as low as 200ns. They are available in small, space-saving packages, which makes these comparators versatile for use in a wide range of applications, from portable to industrial. The open collector output configuration allows the device to be used in wired-OR configurations, such as a window comparators.

### 7.2 Functional Block Diagram

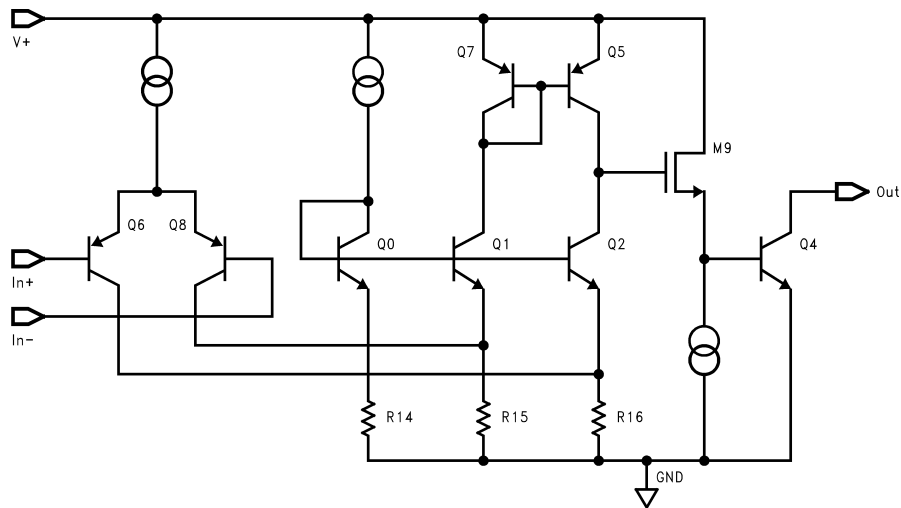

### 7.3 Feature Description

#### 7.3.1 Open Collector Output

The output of the LMV331-N/393-N/339-N series is the uncommitted collector of a grounded-emitter NPN output transistor, which requires a pull-up resistor to a positive supply voltage for the output to switch properly. Many collectors can be tied together to provide an output OR'ing function. An output pull-up resistor can be connected to any available power supply voltage within the permitted V+ supply voltage range. The output pull-up resistor should be chosen high enough so as to avoid excessive power dissipation yet low enough to supply enough drive to switch whatever load circuitry is used on the comparator output. On the LMV331-N/393-N/339-N the pull-up resistor should range between 1 k to 10 k $\Omega$ .

#### 7.3.2 Ground Sensing Input

The LMV331-N/393-N/339-N has a typical input common mode voltage range of  $-0.1\text{V}$  below the ground to  $0.8\text{V}$  below Vcc.

### 7.4 Device Functional Modes

A basic comparator circuit is used for converting analog signals to a digital output.

The output is HIGH when the voltage on the non-inverting (+IN) input is greater than the inverting (-IN) input.

The output is LOW when the voltage on the non-inverting (+IN) input is less than the inverting (-IN) input.

The inverting input (-IN) is also commonly referred to as the "reference" or "V<sub>REF</sub>" input.

## 8 Application and Implementation

### NOTE

Information in the following applications sections is not part of the TI component specification, and TI does not warrant its accuracy or completeness. TI's customers are responsible for determining suitability of components for their purposes. Customers should validate and test their design implementation to confirm system functionality.

### 8.1 Application Information

#### 8.1.1 Basic Comparator

The comparator compares the input voltage ( $V_{IN}$ ) at the non-inverting pin to the reference voltage ( $V_{REF}$ ) at the inverting pin. If  $V_{IN}$  is less than  $V_{REF}$ , the output voltage ( $V_O$ ) is at the saturation voltage. On the other hand, if  $V_{IN}$  is greater than  $V_{REF}$ , the output voltage ( $V_O$ ) is at  $V_{CC}$ .

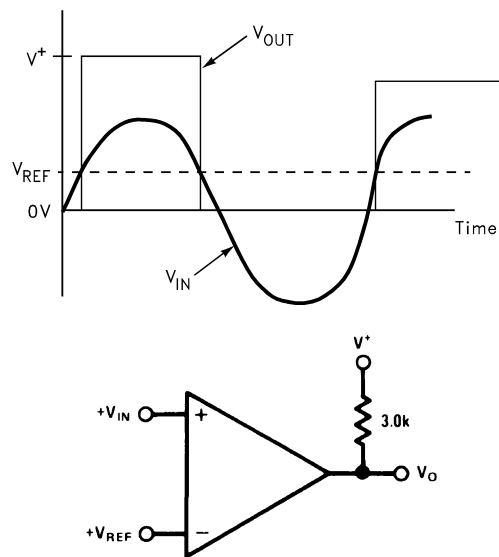

**Figure 10. Basic Comparator**

#### 8.1.2 Comparator With Hysteresis

The basic comparator configuration may oscillate or produce a noisy output if the applied differential input voltage is near the comparator's offset voltage. This usually happens when the input signal is moving very slowly across the switching threshold of the comparator. This problem can be prevented by the addition of hysteresis or positive feedback.

##### 8.1.2.1 Inverting Comparator With Hysteresis

The inverting comparator with hysteresis requires a three resistor network that are referenced to the supply voltage  $V_{CC}$  of the comparator. When  $V_{in}$  at the inverting input is less than  $V_a$ , the voltage at the non-inverting node of the comparator ( $V_{in} < V_a$ ), the output voltage is high (for simplicity assume  $V_O$  switches as high as  $V_{CC}$ ). The three network resistors can be represented as  $R_1//R_3$  in series with  $R_2$ . The lower input trip voltage  $V_{a1}$  is defined as:

$$V_{a1} = \frac{V_{CC} R_2}{(R_1 \parallel R_3) + R_2} \quad (1)$$

When  $V_{in}$  is greater than  $V_a$  ( $V_{in} > V_a$ ), the output voltage is low very close to ground. In this case the three network resistors can be presented as  $R_2//R_3$  in series with  $R_1$ . The upper trip voltage  $V_{a2}$  is defined as:

$$V_{a2} = \frac{V_{CC} (R_2 \parallel R_3)}{R_1 + (R_2 \parallel R_3)} \quad (2)$$

**Application Information (continued)**

The total hysteresis provided by the network is defined as:

$$\Delta V_a = V_{a1} - V_{a2} \tag{3}$$

To assure that the comparator will always switch fully to  $V_{CC}$  and not be pulled down by the load the resistors values should be chosen as follow:

$$R_{PULL-UP} \ll R_{LOAD} \tag{4}$$

$$\text{and } R_1 > R_{PULL-UP} \tag{5}$$

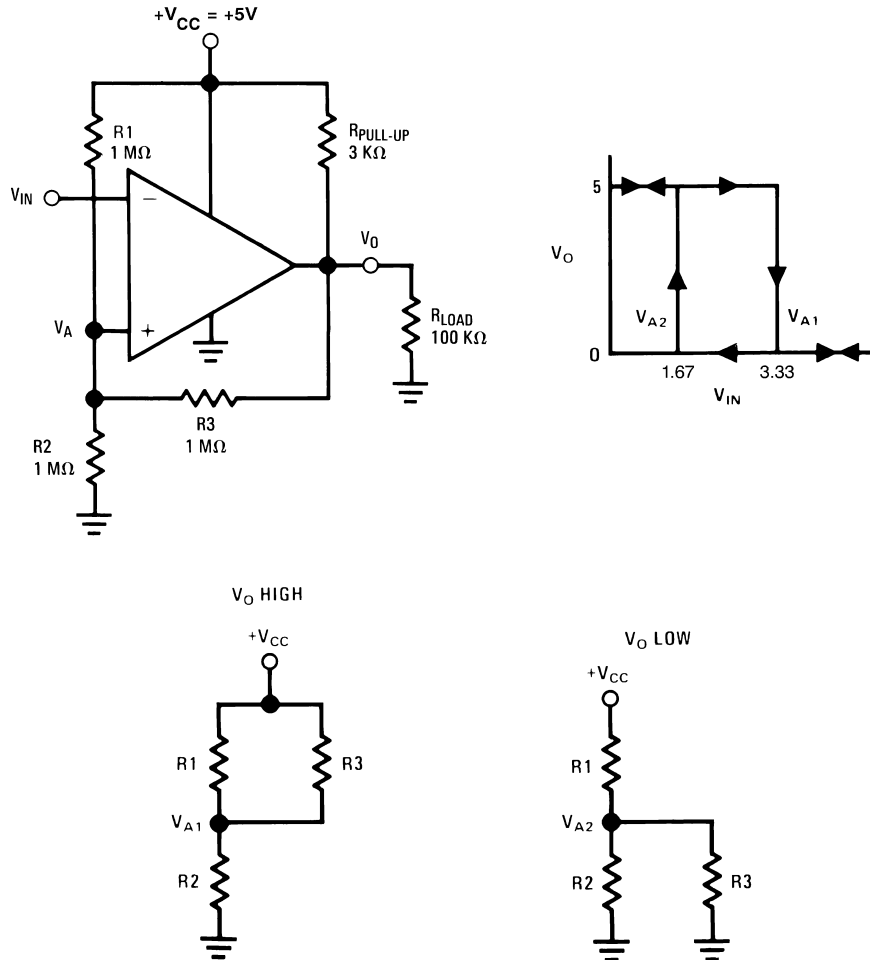

**Figure 11. Inverting Comparator With Hysteresis**

**8.1.2.1.1 Non-inverting Comparator With Hysteresis**

Non-inverting comparator with hysteresis requires a two resistor network, and a voltage reference ( $V_{ref}$ ) at the inverting input. When  $V_{in}$  is low, the output is also low. For the output to switch from low to high,  $V_{in}$  must rise up to  $V_{in1}$  where  $V_{in1}$  is calculated by:

$$V_{in1} = \frac{V_{ref} (R_1 + R_2)}{R_2} \tag{6}$$

When  $V_{in}$  is high, the output is also high. To make the comparator switch back to its low state,  $V_{in}$  must equal  $V_{ref}$  before  $V_A$  will again equal  $V_{ref}$ .  $V_{in}$  can be calculated by:

$$V_{in2} = \frac{V_{ref} (R_1 + R_2) - V_{CC} R_1}{R_2} \tag{7}$$

The hysteresis of this circuit is the difference between  $V_{in1}$  and  $V_{in2}$ .

Application Information (continued)

$$\Delta V_{in} = V_{CC}R_1/R_2 \tag{8}$$

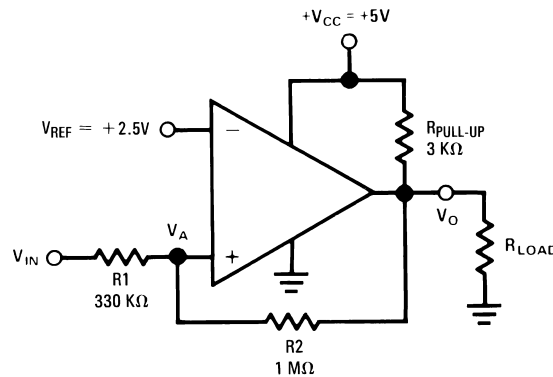

Figure 12. Noninverting Comparator With Hysteresis

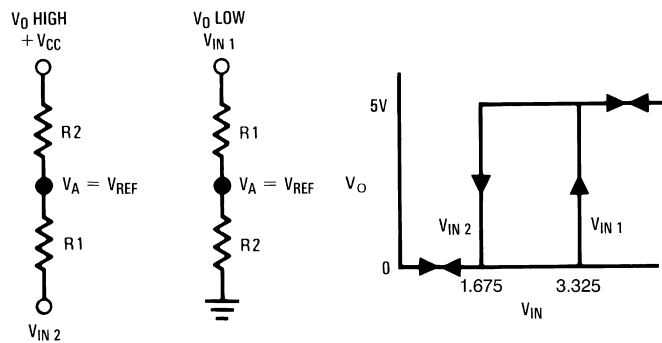

Figure 13. Hysteresis Threshold Points

8.1.3 ORing the Output

By the inherit nature of an open-collector comparator, the outputs of several comparators can be tied together with a shared pull-up resistor to  $V_{CC}$ . If one or more of the comparators outputs goes low, the output  $V_O$  will go low.

Application Information (continued)

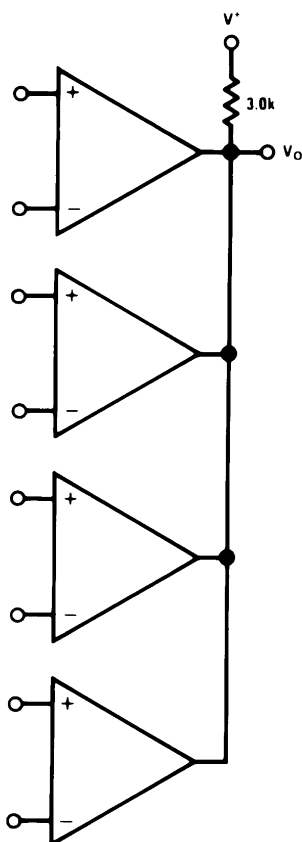

Figure 14. ORing the Outputs

8.1.4 Driving CMOS and TTL

The output of the comparator is capable of driving CMOS and TTL Logic circuits. The pull-up resistor may be pulled-up to any voltage equal to, or less than the supply voltage on  $V+$ . However, it must not be pulled-up to a voltage higher than  $V+$ .

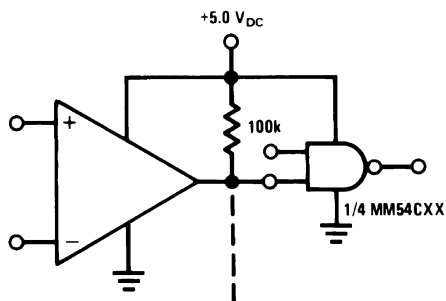
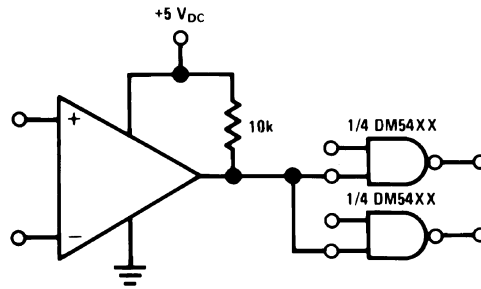

Figure 15. Driving CMOS

## Application Information (continued)



**Figure 16. Driving TTL**

### 8.1.5 AND Gates

The comparator can be used as three input AND gate. The operation of the gate is as follows:

The resistor divider at the inverting input establishes a reference voltage at that node. The non-inverting input is the sum of the voltages at the inputs divided by the voltage dividers. The output will go high only when all three inputs are high, causing the voltage at the non-inverting input to go above that at inverting input. The circuit values shown work for a 0 equal to ground and a 1 equal to 5 V.

The resistor values can be altered if different logic levels are desired. If more inputs are required, diodes are recommended to improve the voltage margin when all but one of the inputs are high.

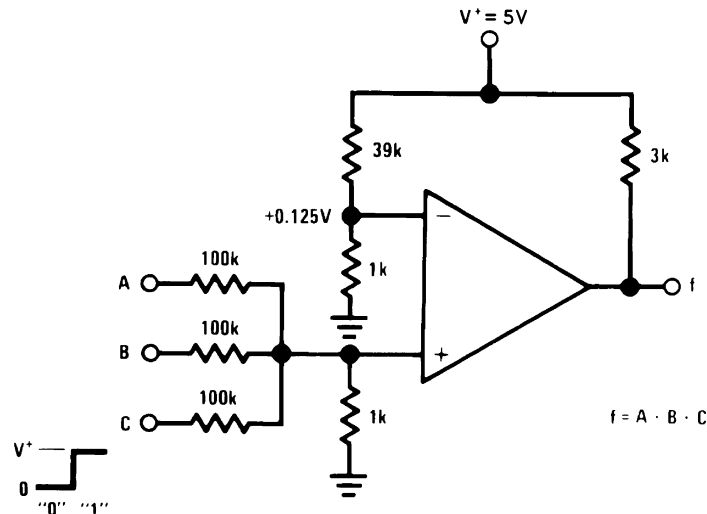

**Figure 17. AND Gate**

### 8.1.6 OR Gates

A three input OR gate is achieved from the basic AND gate simply by increasing the resistor value connected from the inverting input to  $V_{CC}$ , thereby reducing the reference voltage.

A logic 1 at any of the inputs will produce a logic 1 at the output.

Application Information (continued)

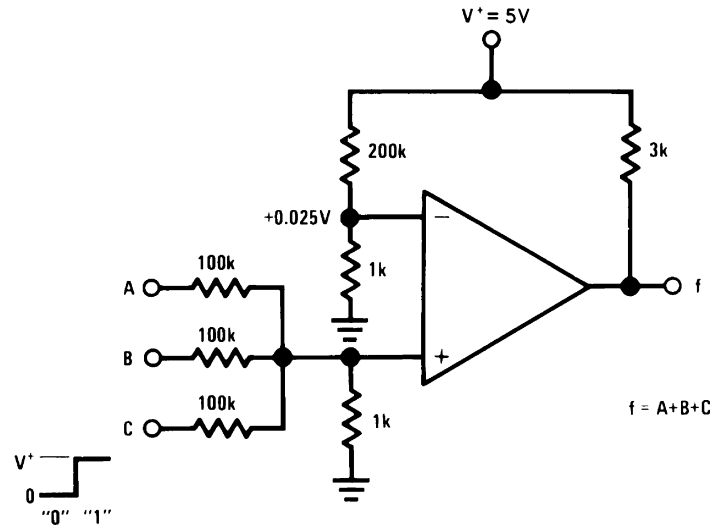

Figure 18. OR Gate

8.1.7 Large Fan-In Gate

Extra logic inputs may be added by ORing the input with multiple diodes.

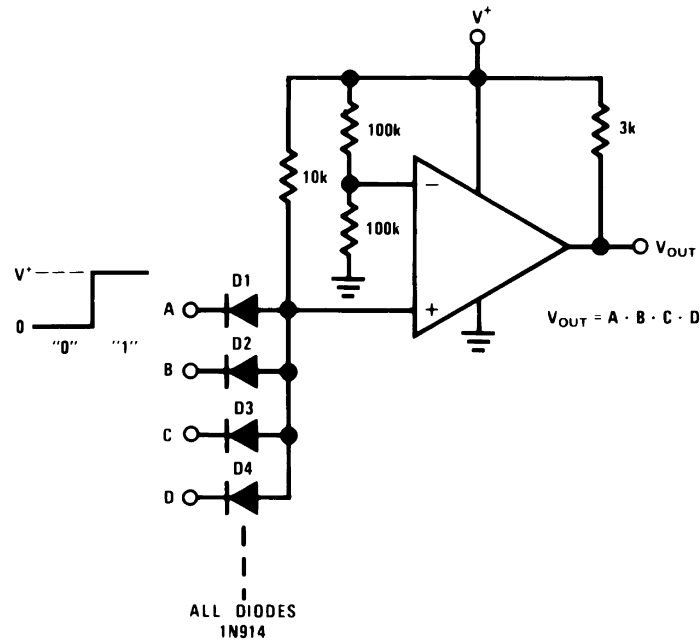
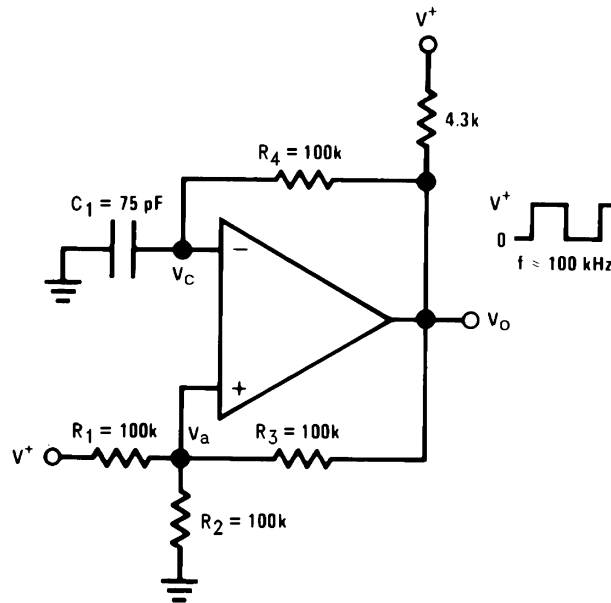

Figure 19. Large Fan-In and Gate

## 8.2 Typical Applications

### 8.2.1 Squarewave Oscillator

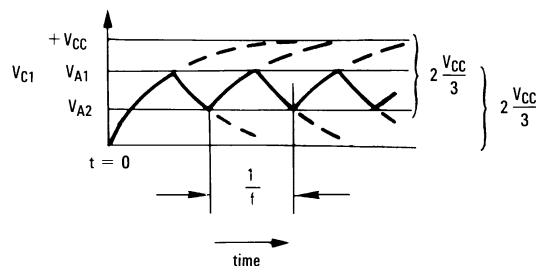

**Figure 20. Squarewave Oscillator**

#### 8.2.1.1 Design Requirements

Comparators are ideal for oscillator applications. This square wave generator uses the minimum number of components. The output frequency is set by the RC time constant of the capacitor  $C_1$  and the resistor in the negative feedback  $R_4$ . The maximum frequency is limited only by the large signal propagation delay of the comparator in addition to any capacitive loading at the output, which would degrade the output slew rate.

#### 8.2.1.2 Detailed Design Procedure



**Figure 21. Squarewave Oscillator Timing Thresholds**

To analyze the circuit, assume that the output is initially high. For this to be true, the voltage at the inverting input  $V_c$  has to be less than the voltage at the non-inverting input  $V_a$ . For  $V_c$  to be low, the capacitor  $C_1$  has to be discharged and will charge up through the negative feedback resistor  $R_4$ . When it has charged up to value equal to the voltage at the positive input  $V_{a1}$ , the comparator output will switch.

$V_{a1}$  will be given by:

$$V_{a1} = \frac{V_{CC} R_2}{R_2 + (R_1 // R_2)} \quad (9)$$

**Typical Applications (continued)**

If:

$$R_1 = R_2 = R_3 \tag{10}$$

Then:

$$V_{a1} = 2V_{CC}/3 \tag{11}$$

When the output switches to ground, the value of  $V_a$  is reduced by the hysteresis network to a value given by:

$$V_{a2} = V_{CC}/3 \tag{12}$$

Capacitor  $C_1$  must now discharge through  $R_4$  towards ground. The output will return to its high state when the voltage across the capacitor has discharged to a value equal to  $V_{a2}$ .

For the circuit shown, the period for one cycle of oscillation will be twice the time it takes for a single RC circuit to charge up to one half of its final value. The time to charge the capacitor can be calculated from:

$$V_C = V_{max} e^{-\frac{t}{RC}} \tag{13}$$

Where  $V_{max}$  is the max applied potential across the capacitor =  $(2V_{CC}/3)$

and  $V_C = V_{max}/2 = V_{CC}/3$

One period will be given by:

$$1/freq = 2t \tag{14}$$

or calculating the exponential gives:

$$1/freq = 2(0.694) R_4 C_1 \tag{15}$$

Resistors  $R_3$  and  $R_4$  must be at least two times larger than  $R_5$  to ensure that  $V_O$  will go all the way up to  $V_{CC}$  in the high state. The frequency stability of this circuit should strictly be a function of the external components.

**8.2.1.3 Application Curve**

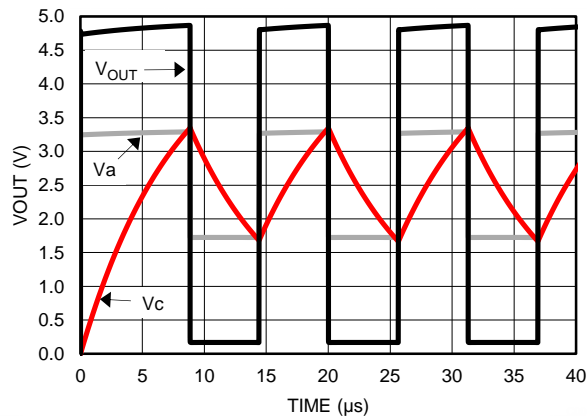

**Figure 22. Waveforms for Circuit in *Typical Applications***

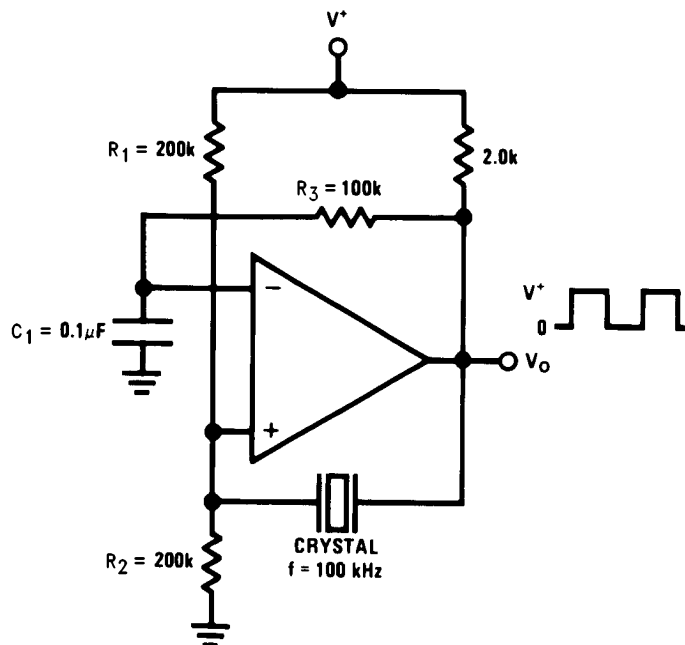
**Typical Applications (continued)**
**8.2.2 Crystal Controlled Oscillator**

**Figure 23. Crystal Controlled Oscillator**

A simple yet very stable oscillator that generates a clock for slower digital systems can be obtained by using a resonator as the feedback element. It is similar to the squarewave oscillator, except that the positive feedback is obtained through a quartz crystal. The circuit oscillates when the transmission through the crystal is at a maximum, so the crystal is in its series-resonant mode.

The value of  $R_1$  and  $R_2$  are equal so that the comparator will switch symmetrically about  $+V_{CC}/2$ . The RC constant of  $R_3$  and  $C_1$  is set to be several times greater than the period of the oscillating frequency, insuring a 50% duty cycle by maintaining a DC voltage at the inverting input equal to the absolute average of the output waveform.

When specifying the crystal, be sure to order series resonant with the desired temperature coefficient.

Typical Applications (continued)

8.2.3 Pulse Generator With Variable Duty Cycle

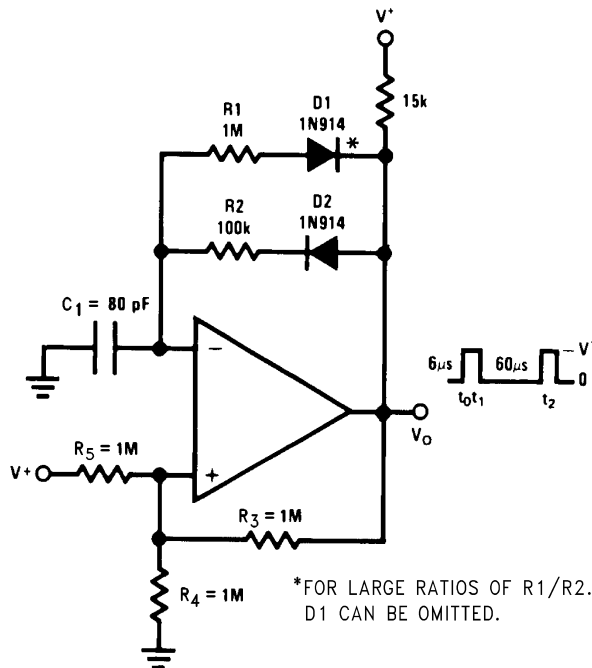

Figure 24. Pulse Generator With Variable Duty Cycle

The pulse generator with variable duty cycle is just a minor modification of the basic square wave generator. Providing a separate charge and discharge path for capacitor C<sub>1</sub> generates a variable duty cycle. One path, through R<sub>2</sub> and D<sub>2</sub> will charge the capacitor and set the pulse width (t<sub>1</sub>). The other path, R<sub>1</sub> and D<sub>1</sub> will discharge the capacitor and set the time between pulses (t<sub>2</sub>).

By varying resistor R<sub>1</sub>, the time between pulses of the generator can be changed without changing the pulse width. Similarly, by varying R<sub>2</sub>, the pulse width will be altered without affecting the time between pulses. Both controls will change the frequency of the generator. The pulse width and time between pulses can be found from:

$$V_1 = V_{max} \left(1 - e^{-t_1/R_4 C_1}\right) \quad \text{rise time}$$

$$V_1 = V_{max} e^{-t_2/R_5 C_1} \quad \text{fall time}$$

Where

$$V_{max} = \frac{2 V_{CC}}{3}$$

and

$$V_1 = \frac{V_{max}}{3} = \frac{V_{CC}}{3}$$

Which gives

$$\frac{1}{2} = e^{-t_1/R_4 C_1}$$

t<sub>2</sub> is then given by:

$$\frac{1}{2} = e^{-t_2/R_5 C_1}$$

(16)

## Typical Applications (continued)

Solving these equations for  $t_1$  and  $t_2$

$$t_1 = R_4 C_1 \ln 2 \quad (17)$$

$$t_2 = R_5 C_1 \ln 2 \quad (18)$$

These terms will have a slight error due to the fact that  $V_{\max}$  is not exactly equal to  $2/3 V_{CC}$  but is actually reduced by the diode drop to:

$$V_{\max} = \frac{2}{3} (V_{CC} - V_{BE}) \quad (19)$$

$$\frac{1}{2(1 - V_{BE})} = e^{-t_1/R_4 C_1} \quad (20)$$

$$\frac{1}{2(1 - V_{BE})} = e^{-t_2/R_5 C_1} \quad (21)$$

### 8.2.4 Positive Peak Detector

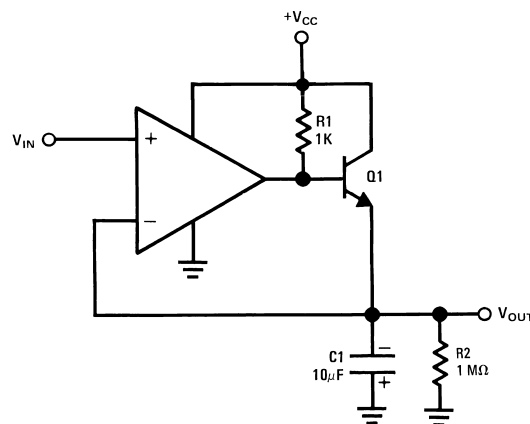

**Figure 25. Positive Peak Detector**

Positive peak detector is basically the comparator operated as a unit gain follower with a large holding capacitor from the output to ground. Additional transistor is added to the output to provide a low impedance current source. When the output of the comparator goes high, current is passed through the transistor to charge up the capacitor. The only discharge path will be the 1-MΩ resistor shunting C1 and any load that is connected to the output. The decay time can be altered simply by changing the 1-MΩ resistor. The output should be used through a high impedance follower to avoid loading the output of the peak detector.

### 8.2.5 Negative Peak Detector

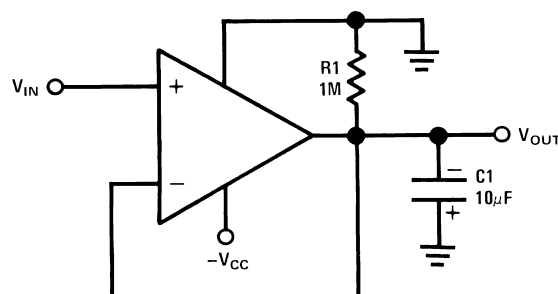

**Figure 26. Negative Peak Detector**

For the negative detector, the output transistor of the comparator acts as a low impedance current sink. The only discharge path will be the 1-MΩ resistor and any load impedance used. Decay time is changed by varying the 1-MΩ resistor.

## 9 Power Supply Recommendations

The TLV170x is specified for operation from 2.2 V to 36 V ( $\pm 1.1$  to  $\pm 18$  V); many specifications apply from  $-40^{\circ}\text{C}$  to  $+125^{\circ}\text{C}$ . Parameters that can exhibit significant variance with regard to operating voltage or temperature are presented in the [Typical Characteristics](#).

### CAUTION

Supply voltages larger than 5.5 V can permanently damage the device; see the [Specifications](#) section.

Place 0.1- $\mu\text{F}$  bypass capacitors close to the power-supply pins to reduce errors coupling in from noisy or high impedance power supplies. For more detailed information on bypass capacitor placement, refer to the [Layout Guidelines](#) section

## 10 Layout

### 10.1 Layout Guidelines

Comparators are very sensitive to input noise. For best results, the following layout guidelines should be maintained:

- Use a printed circuit board (PCB) with a good, unbroken low-inductance ground plane. Proper grounding (use of ground plane) helps maintain specified performance of the comparator
- Connect low-ESR, 0.1- $\mu\text{F}$  ceramic bypass capacitors between each supply pin and ground, placed as close to the device as possible. A single bypass capacitor from  $V+$  to ground is applicable for single supply applications.
- Separate grounding for analog and digital portions of circuitry is one of the simplest and most-effective methods of noise suppression. One or more layers on multilayer PCBs are usually devoted to ground planes. A ground plane helps distribute heat and reduces EMI noise pickup. Make sure to physically separate digital and analog grounds paying attention to the flow of the ground current. For more detailed information refer to [SLOA089, Circuit Board Layout Techniques](#).
- In order to reduce parasitic coupling, run the input traces as far away from the supply or output traces as possible. If it is not possible to keep them separate, it is much better to cross the sensitive trace perpendicular as opposed to in parallel with the noisy trace.
- Place the external components as close to the device as possible, as shown in [Layout Example](#).
- Keep the length of input traces as short as possible. Always remember that the input traces are the most sensitive part of the circuit.
- For slow-moving input signals, take care to prevent parasitic feedback. A small capacitor (1000 pF or less) placed between the inputs can help eliminate oscillations in the transition region. This capacitor causes some degradation to propagation delay when the impedance is low. Run the topside ground plane between the output and inputs.

## 10.2 Layout Example

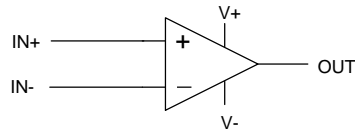

(Schematic Representation)

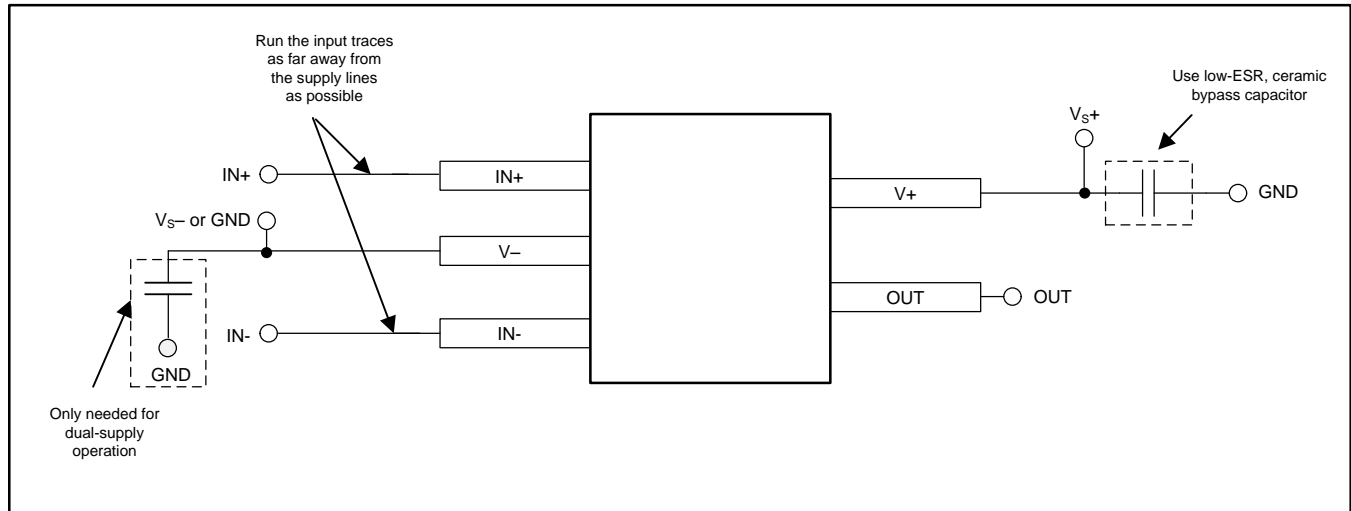

**Figure 27. Comparator Board Layout**

## 11 Device and Documentation Support

### 11.1 Device Support

#### 11.1.1 Development Support

LMV331-N PSPICE Model, [SNOM073](#)

LMV339-N PSPICE Model, [SNOM074](#)

LMV393-N PSPICE Model, [SNOM059](#)

TINA-TI SPICE-Based Analog Simulation Program, <http://www.ti.com/tool/tina-ti>

DIP Adapter Evaluation Module, <http://www.ti.com/tool/dip-adapter-evm>

TI Universal Operational Amplifier Evaluation Module, <http://www.ti.com/tool/opampevm>

### 11.2 Documentation Support

#### 11.2.1 Related Documentation

AN-74 - A Quad of Independently Functioning Comparators, [SNOA654](#)

### 11.3 Related Links

The table below lists quick access links. Categories include technical documents, support and community resources, tools and software, and quick access to sample or buy.

**Table 2. Related Links**

PARTS	PRODUCT FOLDER	SAMPLE & BUY	TECHNICAL DOCUMENTS	TOOLS & SOFTWARE	SUPPORT & COMMUNITY
LMV331-N	<a href="#">Click here</a>	<a href="#">Click here</a>	<a href="#">Click here</a>	<a href="#">Click here</a>	<a href="#">Click here</a>
LMV339-N	<a href="#">Click here</a>	<a href="#">Click here</a>	<a href="#">Click here</a>	<a href="#">Click here</a>	<a href="#">Click here</a>
LMV393-N	<a href="#">Click here</a>	<a href="#">Click here</a>	<a href="#">Click here</a>	<a href="#">Click here</a>	<a href="#">Click here</a>

### 11.4 Trademarks

All trademarks are the property of their respective owners.

### 11.5 Electrostatic Discharge Caution



These devices have limited built-in ESD protection. The leads should be shorted together or the device placed in conductive foam during storage or handling to prevent electrostatic damage to the MOS gates.

### 11.6 Glossary

[SLYZ022](#) — *TI Glossary*.

This glossary lists and explains terms, acronyms, and definitions.

## 12 Mechanical, Packaging, and Orderable Information

The following pages include mechanical, packaging, and orderable information. This information is the most current data available for the designated devices. This data is subject to change without notice and revision of this document. For browser-based versions of this data sheet, refer to the left-hand navigation.

**PACKAGING INFORMATION**

Orderable Device	Status (1)	Package Type	Package Drawing	Pins	Package Qty	Eco Plan (2)	Lead/Ball Finish (6)	MSL Peak Temp (3)	Op Temp (°C)	Device Marking (4/5)	Samples
LMV331M5	ACTIVE	SOT-23	DBV	5	1000	TBD	Call TI	Call TI	-40 to 85	C12	<a href="#">Samples</a>
LMV331M5/NOPB	ACTIVE	SOT-23	DBV	5	1000	Green (RoHS & no Sb/Br)	CU SN	Level-1-260C-UNLIM	-40 to 85	C12	<a href="#">Samples</a>
LMV331M5X	NRND	SOT-23	DBV	5	3000	TBD	Call TI	Call TI	-40 to 85	C12	
LMV331M5X/NOPB	ACTIVE	SOT-23	DBV	5	3000	Green (RoHS & no Sb/Br)	CU SN	Level-1-260C-UNLIM	-40 to 85	C12	<a href="#">Samples</a>
LMV331M7	NRND	SC70	DCK	5	1000	TBD	Call TI	Call TI	-40 to 85	C13	
LMV331M7/NOPB	ACTIVE	SC70	DCK	5	1000	Green (RoHS & no Sb/Br)	CU SN	Level-1-260C-UNLIM	-40 to 85	C13	<a href="#">Samples</a>
LMV331M7X/NOPB	ACTIVE	SC70	DCK	5	3000	Green (RoHS & no Sb/Br)	CU SN	Level-1-260C-UNLIM	-40 to 85	C13	<a href="#">Samples</a>
LMV339M/NOPB	ACTIVE	SOIC	D	14	55	Green (RoHS & no Sb/Br)	CU SN	Level-1-260C-UNLIM	-40 to 85	LMV339M	<a href="#">Samples</a>
LMV339MT	NRND	TSSOP	PW	14	94	TBD	Call TI	Call TI	-40 to 85	LMV339 MT	
LMV339MT/NOPB	ACTIVE	TSSOP	PW	14	94	Green (RoHS & no Sb/Br)	CU SN	Level-1-260C-UNLIM	-40 to 85	LMV339 MT	<a href="#">Samples</a>
LMV339MTX	NRND	TSSOP	PW	14	2500	TBD	Call TI	Call TI	-40 to 85	LMV339 MT	
LMV339MTX/NOPB	ACTIVE	TSSOP	PW	14	2500	Green (RoHS & no Sb/Br)	CU SN	Level-1-260C-UNLIM	-40 to 85	LMV339 MT	<a href="#">Samples</a>
LMV339MX/NOPB	ACTIVE	SOIC	D	14	2500	Green (RoHS & no Sb/Br)	CU SN	Level-1-260C-UNLIM	-40 to 85	LMV339M	<a href="#">Samples</a>
LMV393M	NRND	SOIC	D	8	95	TBD	Call TI	Call TI	-40 to 85	LMV 393M	
LMV393M/NOPB	ACTIVE	SOIC	D	8	95	Green (RoHS & no Sb/Br)	CU SN	Level-1-260C-UNLIM	-40 to 85	LMV 393M	<a href="#">Samples</a>
LMV393MM	NRND	VSSOP	DGK	8	1000	TBD	Call TI	Call TI	-40 to 85	V393	
LMV393MM/NOPB	ACTIVE	VSSOP	DGK	8	1000	Green (RoHS & no Sb/Br)	CU SN	Level-1-260C-UNLIM	-40 to 85	V393	<a href="#">Samples</a>
LMV393MMX/NOPB	ACTIVE	VSSOP	DGK	8	3500	Green (RoHS & no Sb/Br)	CU SN	Level-1-260C-UNLIM	-40 to 85	V393	<a href="#">Samples</a>
LMV393MX	NRND	SOIC	D	8	2500	TBD	Call TI	Call TI	-40 to 85	LMV	

Orderable Device	Status (1)	Package Type	Package Drawing	Pins	Package Qty	Eco Plan (2)	Lead/Ball Finish (6)	MSL Peak Temp (3)	Op Temp (°C)	Device Marking (4/5)	Samples
										393M	
LMV393MX/NOPB	ACTIVE	SOIC	D	8	2500	Green (RoHS & no Sb/Br)	CU SN	Level-1-260C-UNLIM	-40 to 85	LMV 393M	<b>Samples</b>

(1) The marketing status values are defined as follows:

**ACTIVE:** Product device recommended for new designs.

**LIFEBUY:** TI has announced that the device will be discontinued, and a lifetime-buy period is in effect.

**NRND:** Not recommended for new designs. Device is in production to support existing customers, but TI does not recommend using this part in a new design.

**PREVIEW:** Device has been announced but is not in production. Samples may or may not be available.

**OBSOLETE:** TI has discontinued the production of the device.

(2) **RoHS:** TI defines "RoHS" to mean semiconductor products that are compliant with the current EU RoHS requirements for all 10 RoHS substances, including the requirement that RoHS substance do not exceed 0.1% by weight in homogeneous materials. Where designed to be soldered at high temperatures, "RoHS" products are suitable for use in specified lead-free processes. TI may reference these types of products as "Pb-Free".

**RoHS Exempt:** TI defines "RoHS Exempt" to mean products that contain lead but are compliant with EU RoHS pursuant to a specific EU RoHS exemption.

**Green:** TI defines "Green" to mean the content of Chlorine (Cl) and Bromine (Br) based flame retardants meet JS709B low halogen requirements of <=1000ppm threshold. Antimony trioxide based flame retardants must also meet the <=1000ppm threshold requirement.

(3) MSL, Peak Temp. - The Moisture Sensitivity Level rating according to the JEDEC industry standard classifications, and peak solder temperature.

(4) There may be additional marking, which relates to the logo, the lot trace code information, or the environmental category on the device.

(5) Multiple Device Markings will be inside parentheses. Only one Device Marking contained in parentheses and separated by a "~" will appear on a device. If a line is indented then it is a continuation of the previous line and the two combined represent the entire Device Marking for that device.

(6) Lead/Ball Finish - Orderable Devices may have multiple material finish options. Finish options are separated by a vertical ruled line. Lead/Ball Finish values may wrap to two lines if the finish value exceeds the maximum column width.

**Important Information and Disclaimer:** The information provided on this page represents TI's knowledge and belief as of the date that it is provided. TI bases its knowledge and belief on information provided by third parties, and makes no representation or warranty as to the accuracy of such information. Efforts are underway to better integrate information from third parties. TI has taken and continues to take reasonable steps to provide representative and accurate information but may not have conducted destructive testing or chemical analysis on incoming materials and chemicals. TI and TI suppliers consider certain information to be proprietary, and thus CAS numbers and other limited information may not be available for release.

In no event shall TI's liability arising out of such information exceed the total purchase price of the TI part(s) at issue in this document sold by TI to Customer on an annual basis.

**OTHER QUALIFIED VERSIONS OF LMV331-N, LMV393-N :**

- Automotive: [LMV331-Q1](#), [LMV393-Q1](#)

NOTE: Qualified Version Definitions:

- Automotive - Q100 devices qualified for high-reliability automotive applications targeting zero defects

## TAPE AND REEL INFORMATION



### QUADRANT ASSIGNMENTS FOR PIN 1 ORIENTATION IN TAPE



\*All dimensions are nominal

Device	Package Type	Package Drawing	Pins	SPQ	Reel Diameter (mm)	Reel Width W1 (mm)	A0 (mm)	B0 (mm)	K0 (mm)	P1 (mm)	W (mm)	Pin1 Quadrant
LMV331M5	SOT-23	DBV	5	1000	178.0	8.4	3.2	3.2	1.4	4.0	8.0	Q3
LMV331M5/NOPB	SOT-23	DBV	5	1000	178.0	8.4	3.2	3.2	1.4	4.0	8.0	Q3
LMV331M5X	SOT-23	DBV	5	3000	178.0	8.4	3.2	3.2	1.4	4.0	8.0	Q3
LMV331M5X/NOPB	SOT-23	DBV	5	3000	178.0	8.4	3.2	3.2	1.4	4.0	8.0	Q3
LMV331M7	SC70	DCK	5	1000	178.0	8.4	2.25	2.45	1.2	4.0	8.0	Q3
LMV331M7/NOPB	SC70	DCK	5	1000	178.0	8.4	2.25	2.45	1.2	4.0	8.0	Q3
LMV331M7X/NOPB	SC70	DCK	5	3000	178.0	8.4	2.25	2.45	1.2	4.0	8.0	Q3
LMV339MTX	TSSOP	PW	14	2500	330.0	12.4	6.95	5.6	1.6	8.0	12.0	Q1
LMV339MTX/NOPB	TSSOP	PW	14	2500	330.0	12.4	6.95	5.6	1.6	8.0	12.0	Q1
LMV339MX/NOPB	SOIC	D	14	2500	330.0	16.4	6.5	9.35	2.3	8.0	16.0	Q1
LMV393MM	VSSOP	DGK	8	1000	178.0	12.4	5.3	3.4	1.4	8.0	12.0	Q1
LMV393MM/NOPB	VSSOP	DGK	8	1000	178.0	12.4	5.3	3.4	1.4	8.0	12.0	Q1
LMV393MMX/NOPB	VSSOP	DGK	8	3500	330.0	12.4	5.3	3.4	1.4	8.0	12.0	Q1
LMV393MX	SOIC	D	8	2500	330.0	12.4	6.5	5.4	2.0	8.0	12.0	Q1
LMV393MX/NOPB	SOIC	D	8	2500	330.0	12.4	6.5	5.4	2.0	8.0	12.0	Q1

**TAPE AND REEL BOX DIMENSIONS**

\*All dimensions are nominal

Device	Package Type	Package Drawing	Pins	SPQ	Length (mm)	Width (mm)	Height (mm)
LMV331M5	SOT-23	DBV	5	1000	210.0	185.0	35.0
LMV331M5/NOPB	SOT-23	DBV	5	1000	210.0	185.0	35.0
LMV331M5X	SOT-23	DBV	5	3000	210.0	185.0	35.0
LMV331M5X/NOPB	SOT-23	DBV	5	3000	210.0	185.0	35.0
LMV331M7	SC70	DCK	5	1000	210.0	185.0	35.0
LMV331M7/NOPB	SC70	DCK	5	1000	210.0	185.0	35.0
LMV331M7X/NOPB	SC70	DCK	5	3000	210.0	185.0	35.0
LMV339MTX	TSSOP	PW	14	2500	367.0	367.0	35.0
LMV339MTX/NOPB	TSSOP	PW	14	2500	367.0	367.0	35.0
LMV339MX/NOPB	SOIC	D	14	2500	367.0	367.0	35.0
LMV393MM	VSSOP	DGK	8	1000	210.0	185.0	35.0
LMV393MM/NOPB	VSSOP	DGK	8	1000	210.0	185.0	35.0
LMV393MMX/NOPB	VSSOP	DGK	8	3500	367.0	367.0	35.0
LMV393MX	SOIC	D	8	2500	367.0	367.0	35.0
LMV393MX/NOPB	SOIC	D	8	2500	367.0	367.0	35.0

D (R-PDSO-G14)

PLASTIC SMALL OUTLINE



- NOTES:
- A. All linear dimensions are in inches (millimeters).
  - B. This drawing is subject to change without notice.
  - Body length does not include mold flash, protrusions, or gate burrs. Mold flash, protrusions, or gate burrs shall not exceed 0.006 (0,15) each side.
  - Body width does not include interlead flash. Interlead flash shall not exceed 0.017 (0,43) each side.
  - E. Reference JEDEC MS-012 variation AB.

D (R-PDSO-G14)

PLASTIC SMALL OUTLINE

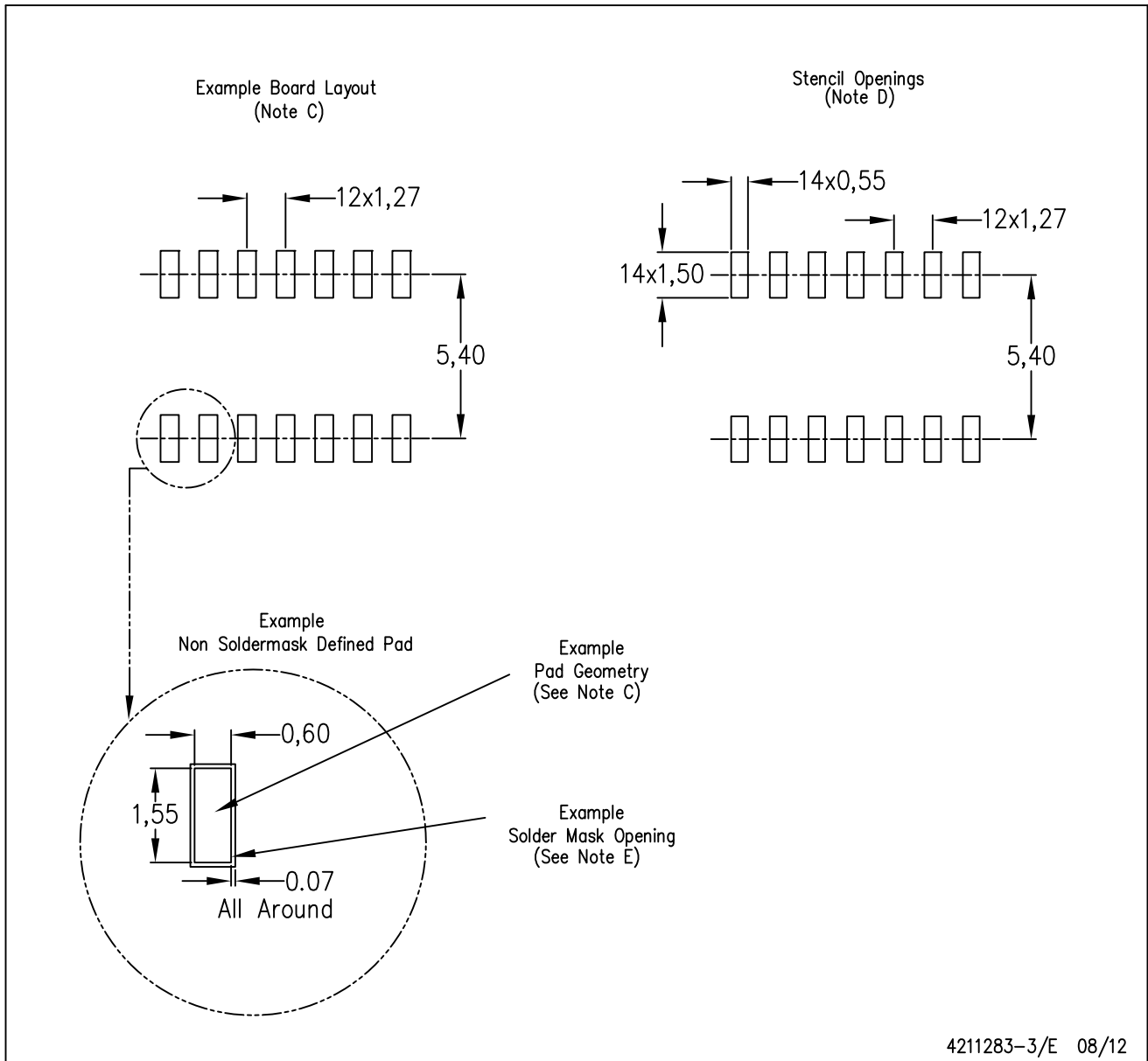

- NOTES:
- A. All linear dimensions are in millimeters.
  - B. This drawing is subject to change without notice.
  - C. Publication IPC-7351 is recommended for alternate designs.
  - D. Laser cutting apertures with trapezoidal walls and also rounding corners will offer better paste release. Customers should contact their board assembly site for stencil design recommendations. Refer to IPC-7525 for other stencil recommendations.
  - E. Customers should contact their board fabrication site for solder mask tolerances between and around signal pads.



PW (R-PDSO-G14)

PLASTIC SMALL OUTLINE



4211284-2/G 08/15

- NOTES:
- A. All linear dimensions are in millimeters.
  - B. This drawing is subject to change without notice.
  - C. Publication IPC-7351 is recommended for alternate designs.
  - D. Laser cutting apertures with trapezoidal walls and also rounding corners will offer better paste release. Customers should contact their board assembly site for stencil design recommendations. Refer to IPC-7525 for other stencil recommendations.
  - E. Customers should contact their board fabrication site for solder mask tolerances between and around signal pads.



D0008A

# PACKAGE OUTLINE

SOIC - 1.75 mm max height

SMALL OUTLINE INTEGRATED CIRCUIT



4214825/C 02/2019

NOTES:

1. Linear dimensions are in inches [millimeters]. Dimensions in parenthesis are for reference only. Controlling dimensions are in inches. Dimensioning and tolerancing per ASME Y14.5M.
2. This drawing is subject to change without notice.
3. This dimension does not include mold flash, protrusions, or gate burrs. Mold flash, protrusions, or gate burrs shall not exceed  $.006$  [0.15] per side.
4. This dimension does not include interlead flash.
5. Reference JEDEC registration MS-012, variation AA.

# EXAMPLE BOARD LAYOUT

D0008A

SOIC - 1.75 mm max height

SMALL OUTLINE INTEGRATED CIRCUIT



LAND PATTERN EXAMPLE  
 EXPOSED METAL SHOWN  
 SCALE:8X



SOLDER MASK DETAILS

4214825/C 02/2019

NOTES: (continued)

- 6. Publication IPC-7351 may have alternate designs.
- 7. Solder mask tolerances between and around signal pads can vary based on board fabrication site.

# EXAMPLE STENCIL DESIGN

D0008A

SOIC - 1.75 mm max height

SMALL OUTLINE INTEGRATED CIRCUIT



SOLDER PASTE EXAMPLE  
BASED ON .005 INCH [0.125 MM] THICK STENCIL  
SCALE:8X

4214825/C 02/2019

NOTES: (continued)

8. Laser cutting apertures with trapezoidal walls and rounded corners may offer better paste release. IPC-7525 may have alternate design recommendations.
9. Board assembly site may have different recommendations for stencil design.

DBV0005A



# PACKAGE OUTLINE

SOT-23 - 1.45 mm max height

SMALL OUTLINE TRANSISTOR



4214839/D 11/2018

NOTES:

1. All linear dimensions are in millimeters. Any dimensions in parenthesis are for reference only. Dimensioning and tolerancing per ASME Y14.5M.
2. This drawing is subject to change without notice.
3. Reference JEDEC MO-178.
4. Body dimensions do not include mold flash, protrusions, or gate burrs. Mold flash, protrusions, or gate burrs shall not exceed 0.15 mm per side.

# EXAMPLE BOARD LAYOUT

DBV0005A

SOT-23 - 1.45 mm max height

SMALL OUTLINE TRANSISTOR



LAND PATTERN EXAMPLE  
EXPOSED METAL SHOWN  
SCALE:15X



SOLDER MASK DETAILS

4214839/D 11/2018

NOTES: (continued)

- 5. Publication IPC-7351 may have alternate designs.
- 6. Solder mask tolerances between and around signal pads can vary based on board fabrication site.

# EXAMPLE STENCIL DESIGN

DBV0005A

SOT-23 - 1.45 mm max height

SMALL OUTLINE TRANSISTOR



SOLDER PASTE EXAMPLE  
BASED ON 0.125 mm THICK STENCIL  
SCALE:15X

4214839/D 11/2018

NOTES: (continued)

7. Laser cutting apertures with trapezoidal walls and rounded corners may offer better paste release. IPC-7525 may have alternate design recommendations.
8. Board assembly site may have different recommendations for stencil design.

DGK (S-PDSO-G8)

PLASTIC SMALL-OUTLINE PACKAGE

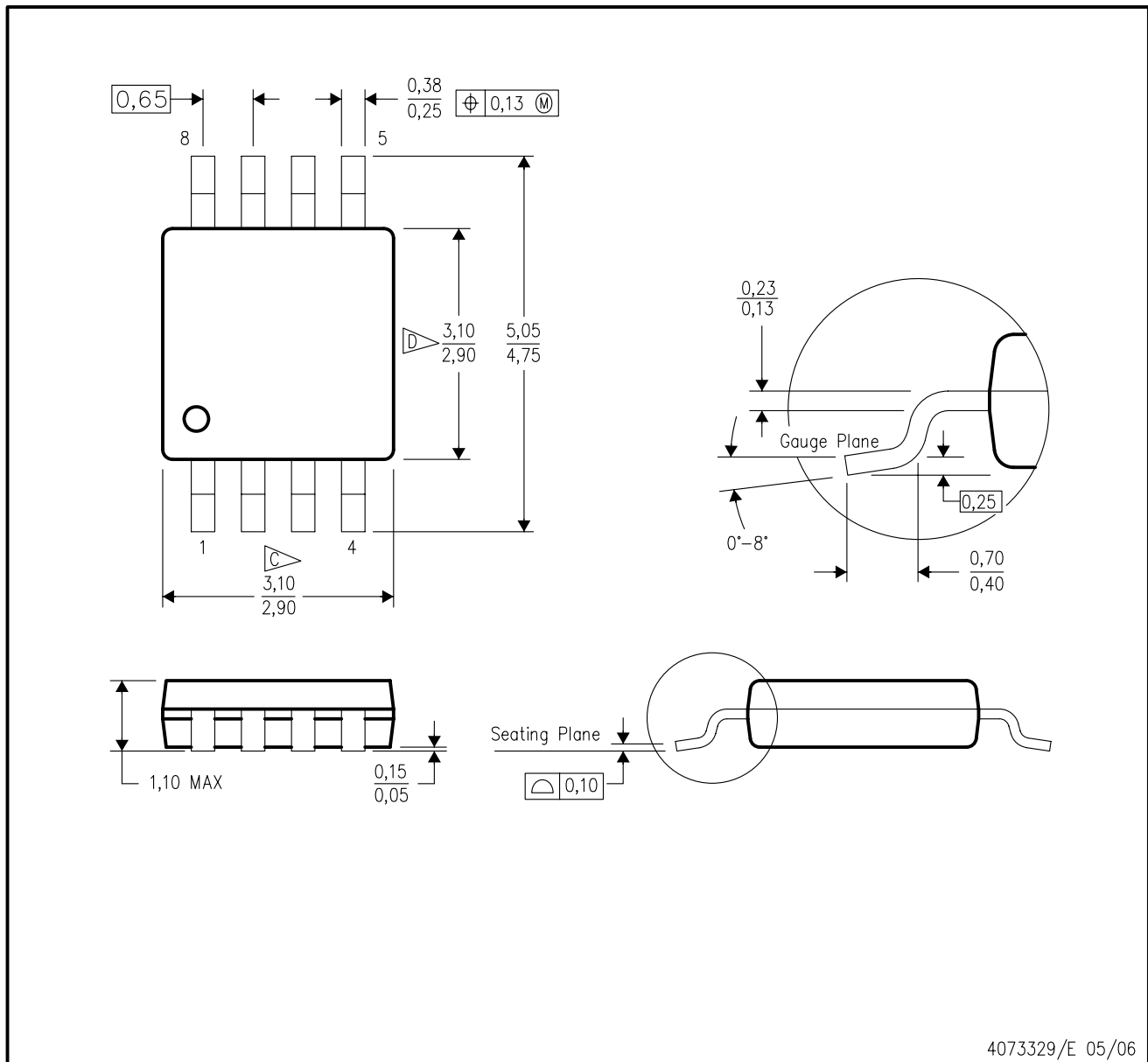

- NOTES:
- A. All linear dimensions are in millimeters.
  - B. This drawing is subject to change without notice.
  - C. Body length does not include mold flash, protrusions, or gate burrs. Mold flash, protrusions, or gate burrs shall not exceed 0.15 per end.
  - D. Body width does not include interlead flash. Interlead flash shall not exceed 0.50 per side.
  - E. Falls within JEDEC MO-187 variation AA, except interlead flash.



- NOTES:
- A. All linear dimensions are in millimeters.
  - B. This drawing is subject to change without notice.
  - C. Publication IPC-7351 is recommended for alternate designs.
  - D. Laser cutting apertures with trapezoidal walls and also rounding corners will offer better paste release. Customers should contact their board assembly site for stencil design recommendations. Refer to IPC-7525 for other stencil recommendations.
  - E. Customers should contact their board fabrication site for solder mask tolerances between and around signal pads.



DCK (R-PDSO-G5)

PLASTIC SMALL OUTLINE

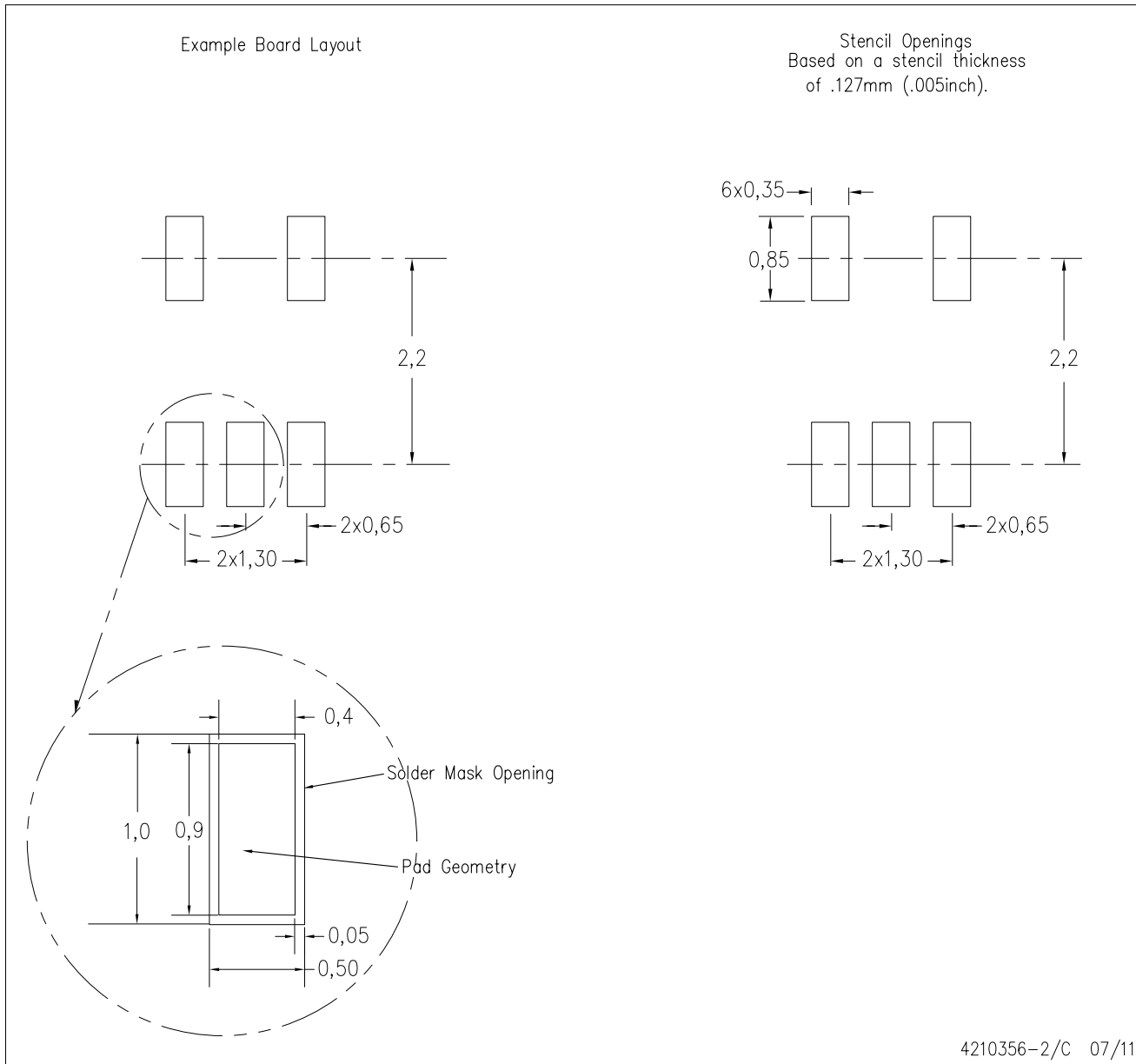

- NOTES:
- All linear dimensions are in millimeters.
  - This drawing is subject to change without notice.
  - Customers should place a note on the circuit board fabrication drawing not to alter the center solder mask defined pad.
  - Publication IPC-7351 is recommended for alternate designs.
  - Laser cutting apertures with trapezoidal walls and also rounding corners will offer better paste release. Customers should contact their board assembly site for stencil design recommendations. Example stencil design based on a 50% volumetric metal load solder paste. Refer to IPC-7525 for other stencil recommendations.

## IMPORTANT NOTICE AND DISCLAIMER

TI PROVIDES TECHNICAL AND RELIABILITY DATA (INCLUDING DATASHEETS), DESIGN RESOURCES (INCLUDING REFERENCE DESIGNS), APPLICATION OR OTHER DESIGN ADVICE, WEB TOOLS, SAFETY INFORMATION, AND OTHER RESOURCES "AS IS" AND WITH ALL FAULTS, AND DISCLAIMS ALL WARRANTIES, EXPRESS AND IMPLIED, INCLUDING WITHOUT LIMITATION ANY IMPLIED WARRANTIES OF MERCHANTABILITY, FITNESS FOR A PARTICULAR PURPOSE OR NON-INFRINGEMENT OF THIRD PARTY INTELLECTUAL PROPERTY RIGHTS.

These resources are intended for skilled developers designing with TI products. You are solely responsible for (1) selecting the appropriate TI products for your application, (2) designing, validating and testing your application, and (3) ensuring your application meets applicable standards, and any other safety, security, or other requirements. These resources are subject to change without notice. TI grants you permission to use these resources only for development of an application that uses the TI products described in the resource. Other reproduction and display of these resources is prohibited. No license is granted to any other TI intellectual property right or to any third party intellectual property right. TI disclaims responsibility for, and you will fully indemnify TI and its representatives against, any claims, damages, costs, losses, and liabilities arising out of your use of these resources.

TI's products are provided subject to TI's Terms of Sale ([www.ti.com/legal/termsofsale.html](http://www.ti.com/legal/termsofsale.html)) or other applicable terms available either on [ti.com](http://ti.com) or provided in conjunction with such TI products. TI's provision of these resources does not expand or otherwise alter TI's applicable warranties or warranty disclaimers for TI products.

Mailing Address: Texas Instruments, Post Office Box 655303, Dallas, Texas 75265  
Copyright © 2019, Texas Instruments Incorporated

## Looking for pricing, stock, or lifecycle information?

Click below to explore more details on WIN SOURCE:

 [View LMV331M7X/NOPB on WIN SOURCE](#)

 [Texas Instruments](#) Information

## Optimize Your Supply Chain with WIN SOURCE Solutions

-  Global Sourcing Solution
-  Obsolete Management
-  Cost Control Management
-  Shortage Management
-  Alternative Solution
-  Excess Inventory Management