



# THE DATASHEET OF LMX1602TM/NOPB



## LMX1600 2.0 GHz/500 MHz, LMX1601 1.1 GHz/500 MHz, LMX1602 1.1 GHz/1.1 GHz PLLatinum™ Low Cost Dual Frequency Synthesizer

Check for Samples: [LMX1600](#), [LMX1601](#), [LMX1602](#)

### FEATURES

- $V_{CC} = 2.7V$  to  $3.6V$  Operation
- **Low Current Consumption:**
  - 4 mA @ 3V (Typ) for LMX1601
  - 5 mA @ 3V (Typ) for LMX1600 or LMX1602
- **PLL Powerdown Mode:**  $I_{CC} = 1 \mu A$  Typical
- **Digital Filtered Lock Detects**
- **Dual Modulus Prescaler:**
  - 2 GHz/500 MHz Option: (Main) 32/33 (Aux) 8/9
  - 1.1 GHz/500 MHz Option: (Main) 16/17 (Aux) 8/9
  - 1.1 GHz/1.1 GHz Option: (Main) 16/17 (Aux) 16/17

### APPLICATIONS

- **Cordless / Cellular / PCS Phones**
- **Other Digital Mobile Phones**

### DESCRIPTION

The LMX1600/01/02 is part of a family of monolithic integrated dual frequency synthesizers designed to be used in a local oscillator subsystem for a radio transceiver. It is fabricated using TI's 0.5u ABiC V silicon BiCMOS process.

The LMX1600/01/02 contains two dual modulus prescalers, four programmable counters, two phase detectors and two selectable gain charge pumps necessary to provide the control voltage for two external loop filters and VCO loops. Digital filtered lock detects for both PLLs are included. Data is transferred into the LMX1600/01/02 via a MICROWIRE serial interface (Data, Clock, LE).

$V_{CC}$  supply voltage can range from 2.7V to 3.6V. The LMX1600/01/02 features very low current consumption - typically 4.0 mA at 3V for LMX1601, 5.0 mA at 3V for LMX1600 or LMX1602. Powerdown for the PLL is hardware controlled.

The LMX1600/01/02 is available in a 16 pin TSSOP surface mount plastic package.

### Functional Block Diagram

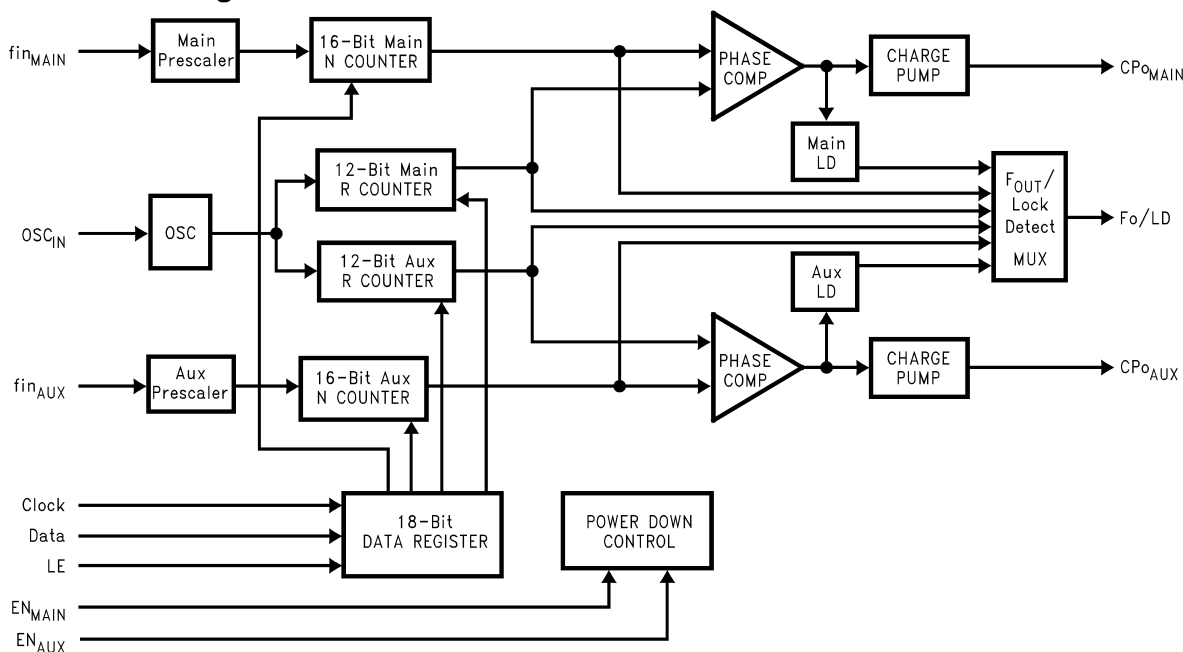

Please be aware that an important notice concerning availability, standard warranty, and use in critical applications of Texas Instruments semiconductor products and disclaimers thereto appears at the end of this data sheet.

PLLatinum is a trademark of Texas Instruments.

All other trademarks are the property of their respective owners.

## Connection Diagrams

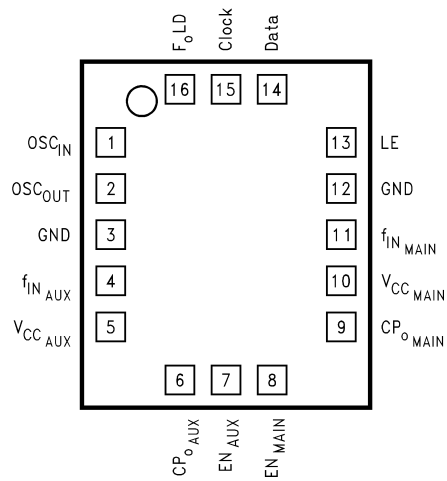

**16 Pin PLGA**  
See Package Number NPG

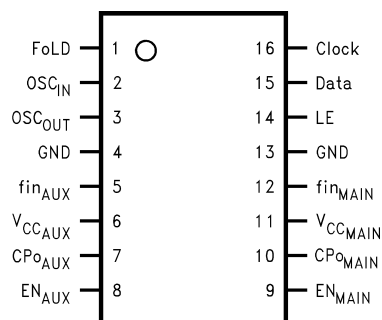

**16 Pin TSSOP**  
See Package Number PW

## PIN DESCRIPTIONS

Pin No. for 16-pin PLGA Package	Pin No. for 16-pin TSSOP Package	Pin Name	I/O	Description
16	1	FoLD	O	Multiplexed output of the Main/Aux programmable or reference dividers and Main/Aux lock detect. CMOS output. (See <a href="#">Programming Description</a> )
1	2	OSC <sub>IN</sub>	I	PLL reference input which drives both the Main and Aux R counter inputs. Has about 1.2V input threshold and can be driven from an external CMOS or TTL logic gate. Typically connected to a TCXO output. Can be used with an external resonator (See <a href="#">Programming Description</a> ).
2	3	OSC <sub>OUT</sub>	O	Oscillator output. Used with an external resonator.
3	4	GND	—	Aux PLL ground.
4	5	fin <sub>AUX</sub>	I	Aux prescaler input. Small signal input from the VCO.
5	6	V <sub>CC</sub> <sub>AUX</sub>	—	Aux PLL power supply voltage input. Must be equal to V <sub>CC</sub> <sub>MAIN</sub> . May range from 2.7V to 3.6V. Bypass capacitors should be placed as close as possible to this pin and be connected directly to the ground plane.
6	7	CPo <sub>AUX</sub>	O	Aux PLL Charge Pump output. Connected to a loop filter for driving the control input of an external VCO.
7	8	EN <sub>AUX</sub>	I	Powers down the Aux PLL when LOW (N and R counters, prescaler, and tristates charge pump output). Bringing EN <sub>AUX</sub> HIGH powers up the Aux PLL.
8	9	EN <sub>MAIN</sub>	I	Powers down the Main PLL when LOW (N and R counters, prescaler, and tristates charge pump output). Bringing EN <sub>MAIN</sub> HIGH powers up the Main PLL.
9	10	CPo <sub>MAIN</sub>	O	Main PLL Charge Pump output. Connected to a loop filter for driving the control input of an external VCO.
10	11	V <sub>CC</sub> <sub>MAIN</sub>	—	Main PLL power supply voltage input. Must be equal to V <sub>CC</sub> <sub>AUX</sub> . May range from 2.7V to 3.6V. Bypass capacitors should be placed as close as possible to this pin and be connected directly to the ground plane.
11	12	fin <sub>MAIN</sub>	I	Main prescaler input. Small signal input from the VCO.
12	13	GND	—	Main PLL ground.
13	14	LE	I	Load enable high impedance CMOS input. Data stored in the shift registers is loaded into one of the 4 internal latches when LE goes HIGH (control bit dependent).
14	15	Data	I	High impedance CMOS input. Binary serial data input. Data entered MSB first. The last two bits are the control bits.
15	16	Clock	I	High impedance CMOS Clock input. Data for the various counters is clocked in on the rising edge, into the 18-bit shift register.



These devices have limited built-in ESD protection. The leads should be shorted together or the device placed in conductive foam during storage or handling to prevent electrostatic damage to the MOS gates.

### Absolute Maximum Ratings<sup>(1)(2)(3)</sup>

Parameter	Symbol	Value			Unit
		Min	Typical	Max	
Power Supply Voltage	$V_{CCMAIN}$	-0.3		6.5	V
	$V_{CCCAUX}$	-0.3		6.5	V
Voltage on any pin with GND=0V	$V_I$	-0.3		$V_{CC} + 0.3$	V
Storage Temperature Range	$T_S$	-65		+150	°C
Lead Temp. (solder 4 sec)	$T_L$			+260	°C
ESD-Human Body Model <sup>(2)</sup>			2000		eV

- (1) "Absolute Maximum Ratings" indicate limits beyond which damage to the device may occur. Recommended Operating Conditions indicate conditions for which the device is intended to be functional, but do not ensure specific performance limits. "Electrical Characteristics" document specific minimum and/or maximum performance values at specified test conditions and are ensured. Typical values are for informational purposes only - based on design parameters or device characterization and are not ensured.
- (2) This device is a high performance RF integrated circuit and is ESD sensitive. Handling and assembly of this device should only be done on ESD-free workstations.
- (3) If Military/Aerospace specified devices are required, please contact the Texas Instruments Sales Office/ Distributors for availability and specifications.

### Recommended Operating Conditions

Parameter	Symbol	Value			Unit
		Min	Typical	Max	
Power Supply Voltage	$V_{CCMAIN}$	2.7		3.6	V
	$V_{CCCAUX}$	$V_{CCMAIN}$		$V_{CCMAIN}$	V
Operating Temperature	$T_A$	-40		+85	°C

## Electrical Characteristics

( $V_{CCMAIN} = V_{CCAUX} = 3.0V$ ;  $T_A = 25^\circ C$  except as specified)

Symbol	Parameter	Conditions	Min	Typ	Max	Units
<b>GENERAL</b>						
$I_{CC}$	Power Supply Current	2 GHz + 500 MHz	Crystal Mode <sup>(1)</sup>		5.0	mA
		1.1 GHz + 500 MHz	Crystal Mode <sup>(1)</sup>		4.0	mA
		1.1 GHz + 1.1 GHz	Crystal Mode <sup>(1)</sup>		5.0	mA
		2 GHz Only	Crystal Mode <sup>(1)</sup>		3.5	mA
		1.1 GHz Only	Crystal Mode <sup>(1)</sup>		2.5	mA
		500 MHz Only	Crystal Mode <sup>(1)</sup>		1.5	mA
$I_{CC-PWDN}$	Power Down Current	$EN_{MAIN} = LOW, EN_{AUX} = LOW$		1		$\mu A$
$f_{in}$	$f_{in}$ Operating Frequency	fin Main 2 GHz Option	200		2000	MHz
		fin Main and Aux 1.1 GHz Option	100		1100	MHz
		fin Aux 500 MHz Option	40		500	MHz
$OSC_{IN}$	Oscillator Operating Frequency	Logic Mode <sup>(1)</sup>	1		40	MHz
		Crystal Mode <sup>(1)</sup>	1		20	MHz
$V_{OSC}$	Oscillator Input Sensitivity		0.5		$V_{CC}$	$V_{PP}$
$f_{\phi}$	Maximum Phase Detector Frequency			10		MHz
$P_{fin}$	Main and Aux RF Input Sensitivity		-15		0	dBm
<b>CHARGE PUMP</b>						
$ICP_{o-source}$	RF Charge Pump Output Current (See <a href="#">Programming Description</a> )	$V_{CPo} = V_{CC}/2$ , High Gain Mode			-1600	$\mu A$
$ICP_{o-sink}$		$V_{CPo} = V_{CC}/2$ , High Gain Mode			1600	$\mu A$
$ICP_{o-source}$		$V_{CPo} = V_{CC}/2$ , Low Gain Mode			-160	$\mu A$
$ICP_{o-sink}$		$V_{CPo} = V_{CC}/2$ , Low Gain Mode			160	$\mu A$
$ICP_{o-Tri}$	Charge Pump Tri-state Current	$0.5 \leq V_{CPo} \leq V_{CC}-0.5$			1	nA
<b>DIGITAL INTERFACE (DATA, CLK, LE, EN, FoLD)</b>						
$V_{IH}$	High-Level Input Voltage		$0.8V_{CC}$			V
$V_{IL}$	Low-Level Input Voltage				$0.2V_{CC}$	V
$I_{IH}$	High-Level Input Current	$V_{IH} = V_{CC} = 3.6V^{(2)}$	-1.0		1.0	$\mu A$
$I_{IL}$	Low-Level Input Current	$V_{IL} = 0V; V_{CC} = 3.6V^{(2)}$	-1.0		1.0	$\mu A$
$I_{IH}$	$OSC_{IN}$ Input Current	$V_{IH} = V_{CC} = 3.6V$			100	$\mu A$
$I_{IL}$	$OSC_{IN}$ Input Current	$V_{IL} = 0V; V_{CC} = 3.6V$	-100			$\mu A$
$I_O$	$OSC_{OUT}$ Output Current Magnitude (sink/source) <sup>(3)</sup>	$V_{OUT} = V_{CC}/2$	Logic Mode $V_{CC} = 3.6V^{(1)}$		200	$\mu A$
			Crystal Mode $V_{CC} = 2.7V^{(1)}$	300		$\mu A$
$V_{OH}$	High-Level Output Voltage	$I_{OH} = -500 \mu A$	$V_{CC}-0.4$			V
$V_{OL}$	Low-Level Output Voltage	$I_{OL} = 500 \mu A$			0.4	V
<b>MICROWIRE TIMING</b>						
$t_{CS}$	Data to Clock Set Up Time	See <a href="#">SERIAL DATA INPUT TIMING</a>	50			ns
$t_{CH}$	Data to Clock Hold Time	See <a href="#">SERIAL DATA INPUT TIMING</a>	10			ns
$t_{CWH}$	Clock Pulse Width High	See <a href="#">SERIAL DATA INPUT TIMING</a>	50			ns
$t_{CWL}$	Clock Pulse Width Low	See <a href="#">SERIAL DATA INPUT TIMING</a>	50			ns
$t_{ES}$	Clock to Load Enable Set Up Time	See <a href="#">SERIAL DATA INPUT TIMING</a>	50			ns
$t_{EW}$	Load Enable Pulse Width	See <a href="#">SERIAL DATA INPUT TIMING</a>	50			ns

(1) Refer to [Programming Description](#).

(2) Except fin.

(3) The OSCout Output Current Magnitude is less than or equal to 200 $\mu A$  when the Logic Mode is selected. The OSCout Output Current Magnitude is greater than or equal to 300 $\mu A$  when the Crystal Mode is selected.

## Electrical Characteristics (continued)

( $V_{CCMAIN} = V_{CCAUX} = 3.0V$ ;  $T_A = 25^\circ C$  except as specified)

Symbol	Parameter	Conditions	Min	Typ	Max	Units
<b>CLOSED LOOP SYNTHESIZER PERFORMANCE</b> (TI evaluation board only)						
$RF\phi_n$	Main PLL Phase Noise Floor	See <sup>(4)</sup>		-160		dBc/Hz

(4) Offset frequency = 1 kHz,  $f_{in} = 900$  MHz,  $f_\phi = 25$  kHz,  $N = 3600$ ,  $f_{OSC} = 10$  MHz,  $V_{OSC} > 1.2 V_{PP}$ . Refer to the Application Note, AN-1052, for description of phase noise floor measurement.

## Functional Description

The basic phase-lock-loop (PLL) configuration consists of a high-stability crystal reference oscillator, a frequency synthesizer such as the Texas Instruments LMX1600/01/02, a voltage controlled oscillator (VCO), and a passive loop filter. The frequency synthesizer includes a phase detector, current mode charge pump, as well as programmable reference [R], and feedback [N] frequency dividers. The VCO frequency is established by dividing the crystal reference signal down via the R counter to obtain the comparison frequency. This reference signal,  $f_r$ , is then presented to the input of a phase/frequency detector and compared with another signal,  $f_p$ , the feedback signal, which was obtained by dividing the VCO frequency down using the N counter. The phase/frequency detector's current source outputs pump charge into the loop filter, which then converts the charge into the VCO's control voltage. The phase/frequency comparator's function is to adjust the voltage presented to the VCO until the feedback signal's frequency (and phase) match that of the reference signal. When this "phase-locked" condition exists, the VCO's frequency will be N times that of the comparison frequency, where N is the divider ratio.

### REFERENCE OSCILLATOR INPUTS

The reference oscillator frequency for the Main and Aux PLL's is provided by either an external reference through the  $OSC_{IN}$  pin with the  $OSC_{OUT}$  pin not connected or connected to a 30 pF capacitor to ground in Logic Mode, or an external crystal resonator across the  $OSC_{IN}$  and  $OSC_{OUT}$  pins in Crystal Mode (See [Programming Description](#)). The  $OSC_{IN}$  input can operate to 40 MHz in Logic Mode or to 20 MHz in Crystal Mode with an input sensitivity of  $0.5 V_{PP}$ . The  $OSC_{IN}$  pin drives the Main and Aux R counters. The inputs have a  $\sim 1.2V$  input threshold and can be driven from an external CMOS or TTL logic gate. The  $OSC_{IN}$  pin is typically connected to the output of a Temperature Compensated Crystal Oscillator (TCXO).

### REFERENCE DIVIDERS (R COUNTERS)

The Main and Aux R Counters are clocked through the oscillator block in common. The maximum frequency is 40 MHz in Logic Mode or 20 MHz in crystal Mode. Both R Counters are 12-bit CMOS counters with a divide range from 2 to 4,095. (See [Programming Description](#))

### FEEDBACK DIVIDERS (N COUNTERS)

The Main and Aux N Counters are clocked by the small signal  $f_{in}$  Main and  $f_{in}$  Aux input pins respectively. These inputs should be AC coupled through external capacitors. The Main N counter has an 16-bit equivalent integer divisor configured as a 5-bit A Counter and an 11-bit B Counter offering a continuous divide range from 992 to 65,535 (2 GHz option) or a 4-bit A Counter and a 12-bit B Counter offering a continuous divide range from 240 to 65,535 (1.1 GHz option). The Main N divider incorporates a 32/33 dual modulus prescaler capable of operation from 200 MHz to 2.0 GHz or a 16/17 dual modulus prescaler capable of operation from 100 MHz to 1.1 GHz.

The Aux N divider operates from 100 MHz to 1.1 GHz with a 16/17 prescaler or from 40 MHz to 500 MHz with a 8/9 prescaler. The Aux N counter is a 16-bit integer divider fully programmable from 240 to 65,535 over the frequency range of 100 MHz to 1.1 GHz or from 56 to 32,767 over the frequency range of 40 MHz to 550 MHz. The Aux N counter is configured as a 4-bit A Counter and a 12-bit B Counter. These inputs should be AC coupled through external capacitors. (See [Programming Description](#))

## Prescalers

The RF input to the prescalers consists of the fin pins which are one of two complimentary inputs to a differential pair amplifier. The complimentary inputs are internally coupled to ground with a 10 pF capacitor and not brought out to a pin. The input buffer drives the A counter's ECL D-type flip flops in a dual modulus configuration. A 32/33 for 2.0 GHz option, 16/17 for 1.1 GHz option, or 8/9 for 500 MHz option prescale ratio is provided for the LMX1600/01/02. The prescaler clocks the subsequent CMOS flip-flop chain comprising the fully programmable A and B counters.

## PHASE/FREQUENCY DETECTOR

The Main and Aux phase(/frequency) detectors are driven from their respective N and R counter outputs. The maximum frequency at the phase detector inputs is 10 MHz (unless limited by the minimum continuous divide ratio of the multi modulus prescalers). The phase detector outputs control the charge pumps. The polarity of the pump-up or pump-down control is programmed using **Main\_PD\_Pol** or **Aux\_PD\_Pol** depending on whether Main or Aux VCO characteristics are positive or negative. (See [Programming Description](#)) The phase detector also receives a feedback signal from the charge pump in order to eliminate dead zone.

## CHARGE PUMP

The phase detector's current source outputs pump charge into an external loop filter, which then converts the charge into the VCO's control voltage. The charge pumps steer the charge pump output, CPo, to  $V_{CC}$  (pump-up) or ground (pump-down). When locked, CPo is primarily in a tri-state mode with small corrections. The charge pump output current magnitude can be selected as 160  $\mu$ A or 1600  $\mu$ A using bits **AUX\_CP\_GAIN** and **MAIN\_CP\_GAIN** as shown in [Programming Description](#).

## MICROWIRE SERIAL INTERFACE

The programmable functions are accessed through the MICROWIRE serial interface. The interface is made of 3 functions: clock, data, and latch enable (LE). Serial data for the various counters is clocked in from data on the rising edge of clock, into the 18-bit shift register. Data is entered MSB first. The last two bits decode the internal register address. On the rising edge of LE, data stored in the shift register is loaded into one of the 4 appropriate latches (selected by address bits). Data is loaded from the latch to the counter when counter reaches to zero. A complete programming description is included in the following sections.

## FoLD MULTIFUNCTION OUTPUT

The LMX1600/01/02 programmable output pin (FoLD) can deliver the internal counter outputs, digital lock detects, or CMOS high/low levels.

### Lock Detect

A digital filtered lock detect function is included with each phase detector through an internal digital filter to produce a logic level output available on the Fo/LD output pin, if selected. The lock detect output is high when the error between the phase detector inputs is less than 15 ns for 4 consecutive comparison cycles. The lock detect output is low when the error between the phase detector outputs is more than 30 ns for one comparison cycle. The lock detect output is always low when the PLL is in power down mode. For further description see [Programming Description](#).

## POWER CONTROL

Each PLL is individually power controlled by the device **EN** pin. The **EN<sub>MAIN</sub>** controls the Main PLL, and the **EN<sub>AUX</sub>** controls the Aux PLL. Activation of **EN** = LOW (power down) condition results in the disabling of the respective N and R counters and de-biasing of their respective fin inputs (to a high impedance state). The reference oscillator input block powers down and the OSC<sub>IN</sub> pin reverts to a high impedance state only when both **EN** pins are LOW. Power down forces the respective charge pump and phase comparator logic to a tri-state condition as well as disabling the bandgap reference block. Power up occurs immediately when the **EN** pin is brought high. Power up sequence: Bandgap and Oscillator blocks come up first, with the remaining PLL functions becoming active approx. 1  $\mu$ s later. All programming information is retained internally in the chip when in power down mode. The MICROWIRE control register remains active and capable of loading and latching in data during power down mode.

## Programming Description

### MICROWIRE INTERFACE

The descriptions below detail the 18-bit data register loaded through the MICROWIRE Interface. The 18-bit shift register is used to program the 12-bit Main and Aux R counter registers and the 16-bit Main and Aux N counter registers. The shift register consists of a 16-bit DATA field and a 2-bit control (CTL [1:0]) field as shown below. The control bits decode the internal register address. On the rising edge of LE, data stored in the shift register is loaded into one of the 4 appropriate latches (selected by address bits). Data is shifted in MSB first.

MSB		LSB
	DATA [15:0]	CTL [1:0]
18	2 1	0

### Register Location Truth Table

When LE transitions high, data is transferred from the 18-bit shift register into one of the 4 appropriate internal latches depending upon the state of the control (CTL) bits. The control bits decode the internal register address

CTL [1:0]		DATA Location
0	0	AUX_R Register
0	1	AUX_N Register
1	0	MAIN_R Register
1	1	MAIN_N Register

### Register Content Truth Table

	SHIFT REGISTER BIT LOCATION																Last Bit	
	17	16	15	14	13	12	11	10	9	8	7	6	5	4	3	2	1	0
AUX_R	FoLD				AUX_R_CNTR												0	0
AUX_N	AUX_B_CNTR												AUX_A_CNTR				0	1
MAIN_R	CP_WORD				MAIN_R_CNTR												1	0
MAIN_N	MAIN_B_CNTR and MAIN_A_CNTR																1	1

## PROGRAMMABLE REFERENCE DIVIDERS

### AUX\_R Register

If the Control Bits (CTL [1:0]) are 0 0 when LE transitions high, data is transferred from the 18-bit shift register into a latch which sets the Aux PLL 12-bit R counter divide ratio. The divide ratio is programmed using the bits **AUX\_R\_CNTR** as shown in [12-Bit Programmable Main and Auxiliary Reference Divider Ratio \(MAIN/AUX R Counter\)](#). The divider ratio must be  $\geq 2$ . The FoLD word bits controls the multifunction FoLD output as described in [Programming Description](#).

	SHIFT REGISTER BIT LOCATION																Last Bit	
	17	16	15	14	13	12	11	10	9	8	7	6	5	4	3	2	1	0
AUX_R	FoLD[3:0]				AUX_R_CNTR[11:0]												0	0

## MAIN\_R REGISTER

If the Control Bits (CTL [1:0]) are 1 0 when LE transitions high, data is transferred from the 18-bit shift register into a latch which sets the Main PLL 12-bit R counter divide ratio and various control functions. The divide ratio is programmed using the bits **MAIN\_R\_CNTR** as shown in [12-Bit Programmable Main and Auxiliary Reference Divider Ratio \(MAIN/AUX R Counter\)](#). The divider ratio must be  $\geq 2$ . The charge pump control word (CP\_WORD[3:0]) sets the charge pump gain and the phase detector polarity as detailed in [CHARGE PUMP CONTROL WORD \(CP\\_WORD\)](#).

	SHIFT REGISTER BIT LOCATION																	
	First Bit																Last Bit	
	17	16	15	14	13	12	11	10	9	8	7	6	5	4	3	2	1	0
MAIN_R	CP_WORD[3:0]				MAIN_R_CNTR[11:0]												1	0

## 12-Bit Programmable Main and Auxiliary Reference Divider Ratio (MAIN/AUX R Counter)

MAIN_R_CNTR/AUX_R_CNTR												
Divide Ratio <sup>(1)</sup>	11	10	9	8	7	6	5	4	3	2	1	0
2	0	0	0	0	0	0	0	0	0	0	1	0
3	0	0	0	0	0	0	0	0	0	0	1	1
•	•	•	•	•	•	•	•	•	•	•	•	•
4,095	1	1	1	1	1	1	1	1	1	1	1	1

(1) Legal divide ratio: 2 to 4,095.

## PROGRAMMABLE FEEDBACK (N) DIVIDERS

### AUX\_N Register

If the Control Bits (CTL[1:0]) are 0 1 when LE transitions high, data is transferred from the 18-bit shift register into the AUX\_N register latch which sets the Aux PLL 16-bit programmable N counter value. The AUX\_N counter is a 16-bit counter which is fully programmable from 240 to 65,535 for 1.1 GHz option or from 56 to 32,767 for 500 MHz option. The AUX\_N register consists of the 4-bit swallow counter (AUX\_A\_CNTR), the 12-bit programmable counter (AUX\_B\_CNTR). Serial data format is shown below. The divide ratio (AUX\_N\_CNTR [13:0]) must be  $\geq 240$  (1.1 GHz option) or  $\geq 56$  (500 MHz option) for a continuous divide range. The Aux PLL N divide ratio is programmed using the bits AUX\_A\_CNTR, AUX\_B\_CNTR as shown in [4-BIT Swallow Counter Divide Ratio \(Aux A COUNTER\)](#).

	First Bit				SHIFT REGISTER BIT LOCATION												Last Bit	
	17	16	15	14	13	12	11	10	9	8	7	6	5	4	3	2	1	0
AUX_N	AUX_B_CNTR[11:0]												AUX_A_CNTR[3:0]		0	1		

## 4-BIT Swallow Counter Divide Ratio (Aux A COUNTER)

Table 1. 1.1 GHz Option

Swallow Count <sup>(1)</sup>	AUX_A_CNTR			
	3	2	1	0
(A)	3	2	1	0
0	0	0	0	0
1	0	0	0	1
•	•	•	•	•
15	1	1	1	1

(1) Swallow Counter Value: 0 to 15

**Table 2. 500 MHz Option<sup>(1)</sup>**

Swallow Count <sup>(2)</sup>	AUX_A_CNTR			
	3	2	1	0
(A)	3	2	1	0
0	X	0	0	0
1	X	0	0	1
•	•	•	•	•
7	X	1	1	1

(1) X = Don't Care condition

(2) Swallow Counter Value: 0 to 7

**12-BIT Programmable Counter Divide Ratio (Aux B COUNTER)**

Divide Ratio <sup>(3)</sup>	AUX_B_CNTR <sup>(1)(2)</sup>											
	11	10	9	8	7	6	5	4	3	2	1	0
3	0	0	0	0	0	0	0	0	0	0	1	1
4	0	0	0	0	0	0	0	0	0	1	0	0
•	•	•	•	•	•	•	•	•	•	•	•	•
4,095	1	1	1	1	1	1	1	1	1	1	1	1

(1)  $AUX\_B\_CNTR \geq AUX\_A\_CNTR$ (2) See [PROGRAMMABLE FEEDBACK \(N\) DIVIDERS](#) for calculation of VCO output frequency

(3) Divide ratio: 3 to 4,095 (Divide ratios less than 3 are prohibited)

**MAIN\_N Register**

If the Control Bits (CTL[1:0]) are 1 1 when LE transitions high, data is transferred from the 18-bit shift register into the MAIN\_N register latch which sets 16-bit programmable N divider value. The Main N divider is a 16-bit counter which is fully programmable from 992 to 65,535 for 2 GHz option and from 240 to 65,535 for 1.1 GHz option. The MAIN\_N register consists of the 5-bit (2 GHz option) or 4-bit (1.1 GHz option) swallow counter (MAIN\_A\_CNTR) and the 11-bit (2 GHz option) or 12-bit (1.1 GHz option) programmable counter (MAIN\_B\_CNTR). Serial data format for the MAIN\_N register latch shown below. The divide ratio must be  $\geq 992$  (2 GHz option) or  $> 240$  (1.1 GHz option) for a continuous divide range. The divide ratio is programmed using the bits MAIN\_A\_CNTR and MAIN\_B\_CNTR as shown in [Swallow Counter Divide Ratio \(Main A COUNTER\)](#) and [Programmable Counter Divide Ratio \(Main B COUNTER\)](#). The pulse swallow function which determines the divide ratio is described in [Pulse Swallow Function](#).

**Table 3. 2 GHz Option**

	First Bit				SHIFT REGISTER BIT LOCATION												Last Bit	
	17	16	15	14	13	12	11	10	9	8	7	6	5	4	3	2	1	0
MAIN_N	AUX_B_CNTR[10:0]										AUX_A_CNTR[4:0]				1	1		

**Table 4. 1.1 GHz Option**

	First Bit				SHIFT REGISTER BIT LOCATION												Last Bit	
	17	16	15	14	13	12	11	10	9	8	7	6	5	4	3	2	1	0
MAIN_N	AUX_B_CNTR[11:0]											AUX_A_CNTR[3:0]			1	1		

**Swallow Counter Divide Ratio (Main A COUNTER)**
**Table 5. 2 GHz Option (5 Bit)**

Swallow Count <sup>(1)</sup>	MAIN_A_CNTR				
	4	3	2	1	0
(A)					
0	0	0	0	0	0
1	0	0	0	0	1
•	•	•	•	•	•
31	1	1	1	1	1

(1) Swallow Counter Value: 0 to 31

**Table 6. 1.1 GHz Option (4 Bit)**

Swallow Count <sup>(1)</sup>	MAIN_A_CNTR			
	3	2	1	0
(A)				
0	0	0	0	0
1	0	0	0	1
•	•	•	•	•
15	1	1	1	1

(1) Swallow Counter Value: 0 to 15

**Programmable Counter Divide Ratio (Main B COUNTER)**
**Table 7. 2 GHz Option (11 Bit)<sup>(1)</sup>**

Divide Ratio <sup>(3)</sup>	MAIN_B_CNTR <sup>(2)</sup>										
	10	9	8	7	6	5	4	3	2	1	0
3	0	0	0	0	0	0	0	0	0	1	1
4	0	0	0	0	0	0	0	0	1	0	0
•	•	•	•	•	•	•	•	•	•	•	•
2,047	1	1	1	1	1	1	1	1	1	1	1

 (1) See [Pulse Swallow Function](#) for calculation of VCO output frequency

(2) MAIN\_B\_CNTR ≥ MAIN\_A\_CNTR

(3) Divide ratio: 3 to 2,047 (Divide ratios less than 3 are prohibited)

**Table 8. 1.1 GHz Option (12 Bit)<sup>(1)</sup>**

Divide Ratio <sup>(3)</sup>	MAIN_B_CNTR <sup>(2)</sup>											
	11	10	9	8	7	6	5	4	3	2	1	0
3	0	0	0	0	0	0	0	0	0	0	1	1
4	0	0	0	0	0	0	0	0	0	1	0	0
•	•	•	•	•	•	•	•	•	•	•	•	•
4,095	1	1	1	1	1	1	1	1	1	1	1	1

 (1) See [Pulse Swallow Function](#) for calculation of VCO output frequency.

(2) MAIN\_B\_CNTR ≥ MAIN\_A\_CNTR

(3) Divide ratio: 3 to 4,095 (Divide ratios less than 3 are prohibited)

## Pulse Swallow Function

The N divider counts such that it divides the VCO RF frequency by (P+1) for A times, and then divides by P for (B – A) times. The B value (B\_CNTR) must be  $\geq 3$ . The continuous divider range for the Main PLL N divider is from 992 to 65,535 for 2 GHz option, from 240 to 65,535 for 1.1 GHz option, and from 56 to 32,767 for 500 MHz option. Divider ratios less than the minimum value are achievable as long as the binary counter value is greater than or equal to the swallow counter value ( $B\_CNTR \geq A\_CNTR$ ).

$$f_{VCO} = N \times (f_{OSC} / R)$$

where

- $f_{VCO}$ : Output frequency of external voltage controlled oscillator (VCO)
- $f_{OSC}$ : Output frequency of the external reference frequency oscillator (input to OSC<sub>IN</sub>).
- R: Preset divide ratio of binary programmable reference counter (R\_CNTR)

(1)

$$N = (P \times B) + A$$

where

- N: Preset divide ratio of main programmable integer N counter (N\_CNTR)
- B: Preset divide ratio of binary programmable B counter (B\_CNTR)
- A: Preset value of binary 4-bit swallow A counter (A\_CNTR)
- P: Preset modulus of dual modulus prescaler (P = 32 for 2 GHz option, P=16 for 1.1 GHz option, and P=8 for 500 MHz option)

(2)

## CHARGE PUMP CONTROL WORD (CP\_WORD)

MSB		LSB	
AUX_CP_GAIN	MAIN_CP_GAIN	AUX_PD_POL	MAIN_PD_POL

BIT	LOCATION	FUNCTION	0	1
AUX_CP_GAIN	MAIN_R[17]	Aux Charge Pump Current Gain	LOW	HIGH
MAIN_CP_GAIN	MAIN_R[16]	Main Charge Pump Current Gain	LOW	HIGH
AUX_PD_POL	MAIN_R[15]	Aux Phase Detector Polarity	Negative	Positive
MAIN_PD_POL	MAIN_R[14]	Main Phase Detector Polarity	Negative	Positive

**AUX\_CP\_GAIN** (MAIN\_R[17]) and **MAIN\_CP\_GAIN** (MAIN\_R[16]) are used to select charge pump current magnitude either low gain mode (160  $\mu$ A typ) or high gain mode (1600  $\mu$ A typ)

**AUX\_PD\_POL** (MAIN\_R[15]) and **MAIN\_PD\_POL** (MAIN\_R[14]) are respectively set to one when Aux or Main VCO characteristics are positive as in (1) below. When VCO frequency decreases with increasing control voltage (2) **PD\_POL** should set to zero.

## VCO Characteristics

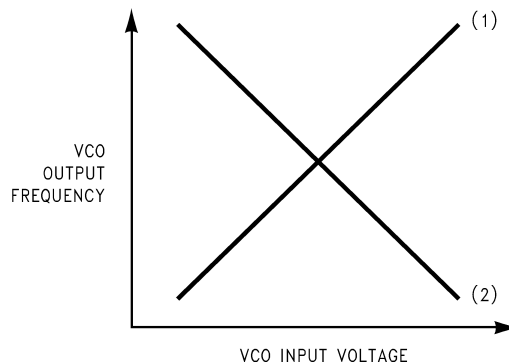

**Phase Comparator and Internal Charge Pump Characteristics**  
(AUX\_PD\_POL/MAIN\_PD\_POL = 1)

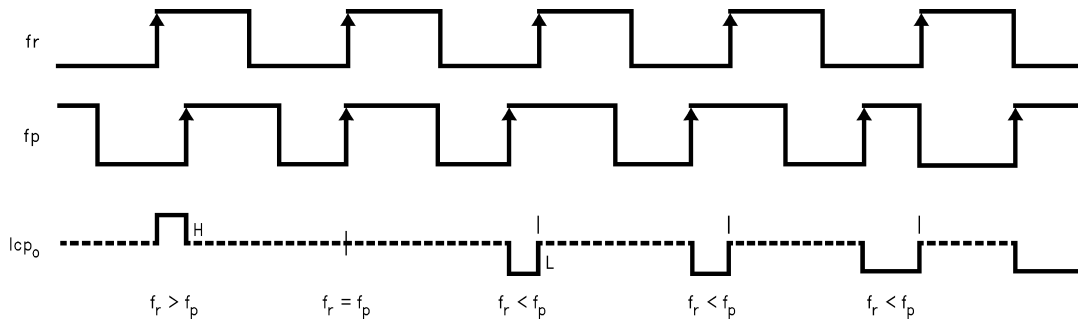

$f_r$  is phase detector input from reference counter.  $f_p$  is phase detector input from programmable N counter.  
Phase difference detection range:  $-2\pi$  to  $+2\pi$ .  
The minimum width pump up and pump down current pulses occur at the CPo pin when the loop is locked.

**F<sub>OUT</sub>/LOCK DETECT PROGRAMMING TRUTH TABLE (FoLD)**

FoLD				Fo/LD OUTPUT STATE
3	2	1	0	
AUX_R[17]	AUX_R[16]	AUX_R[15]	AUX_R[14] <sup>(1)</sup>	
0	0	0	0	"0"
0	0	0	1	"1"
0	0	1	X	Main Lock Detect
0	1	0	x	Aux Lock Detect
0	1	1	X	Main "and" Aux Lock Detect
1	0	0	X	Main Reference Counter Output
1	0	1	X	Aux Reference Counter Output
1	1	0	X	Main Programmable Counter Output
1	1	1	X	Aux Programmable Counter Output

(1) See [OSC Mode Programming](#) for AUX\_R[14] description.

**Lock Detect Digital Filter**

The Lock Detect Digital Filter compares the difference between the phase of the inputs of the phase detector to a RC generated delay of approximately 15 ns. To enter the locked state (Lock = HIGH) the phase error must be less than the 15 ns RC delay for 4 consecutive reference cycles. Once in lock (Lock = HIGH), the RC delay is changed to approximately 30 ns. To exit the locked state (Lock = LOW), the phase error must become greater than the 30 ns RC delay. When the PLL is in the powerdown mode, Lock is forced LOW. A flow chart of the digital filter is shown below.

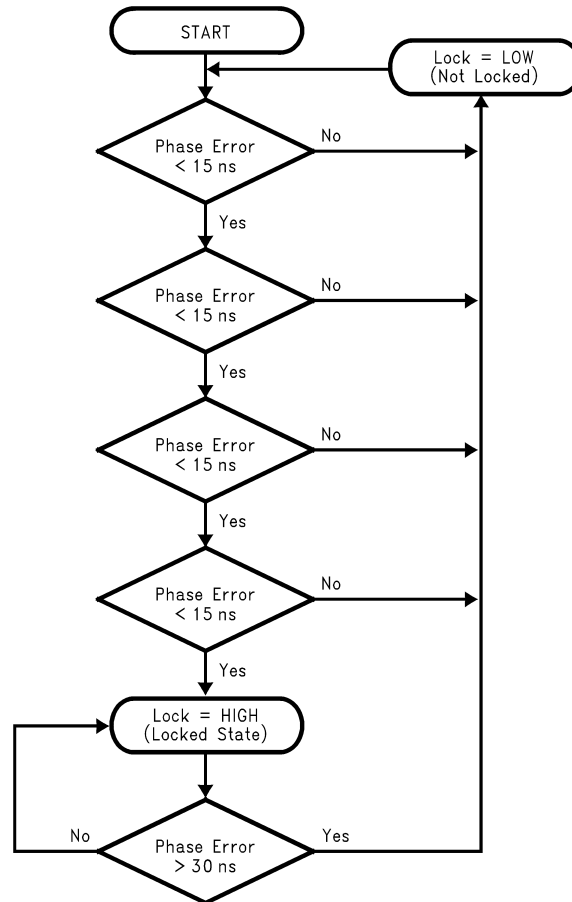

### Typical Lock Detect Timing (AUX\_PD\_POL/MAIN\_PD\_POL = 1)

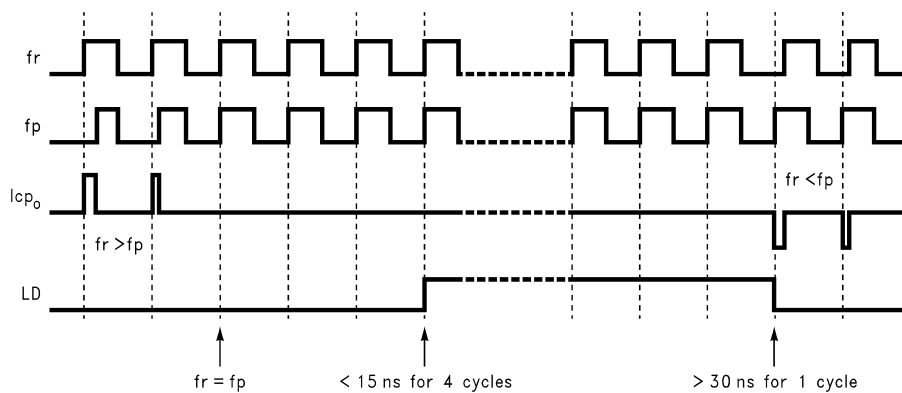

### OSC Mode Programming

The OSC<sub>OUT</sub> pin can be optimized for operating with an external crystal resonator or an external reference frequency source (i.e. TCXO). If the application uses an external reference frequency source, the current dissipation of the LMX1600/01/02 can be reduced with the Logic Mode (0.5 mA typ.). Crystal Mode should be used when an external crystal resonator is used. Logic Mode is used when an external reference frequency source is used. In Logic Mode, OSC<sub>OUT</sub> should be connected to a 30 pF capacitor to ground for optimum performance.

When the FoLD output state is selected to CMOS high/low levels, the OSC Mode is forced to Crystal Mode.

FoLD				OSC <sub>OUT</sub>
3	2	1	0	
AUX_R[17]	AUX_R[16]	AUX_R[15]	AUX_R[14]	
0	0	0	0	Crystal Mode
0	0	0	1	Crystal Mode
All Other States			0	Logic Mode
			1	Crystal Mode

### Typical Crystal Oscillator Circuit

A typical implementation of a 10 MHz crystal oscillator with the OSC<sub>OUT</sub> pin in Crystal Mode is shown below.

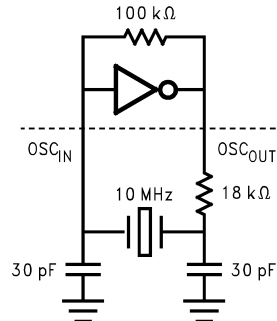

### SERIAL DATA INPUT TIMING

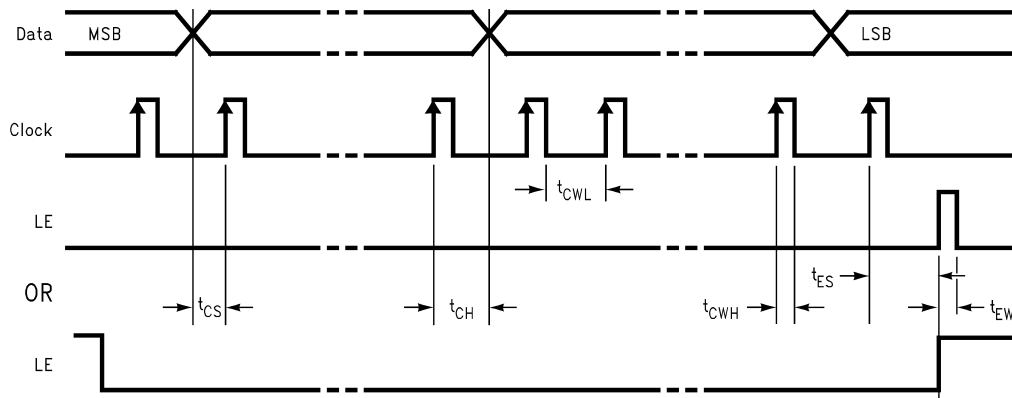

Data shifted into register on clock rising edge.  
Data is shifted in MSB first.

**TEST CONDITIONS:** The Serial Data Input Timing is tested using a symmetrical waveform around  $V_{CC}/2$ . The test waveform has an edge rate of 0.6 V/ns with amplitudes of 2.2V @  $V_{CC} = 2.7V$ .

## TYPICAL APPLICATION EXAMPLE

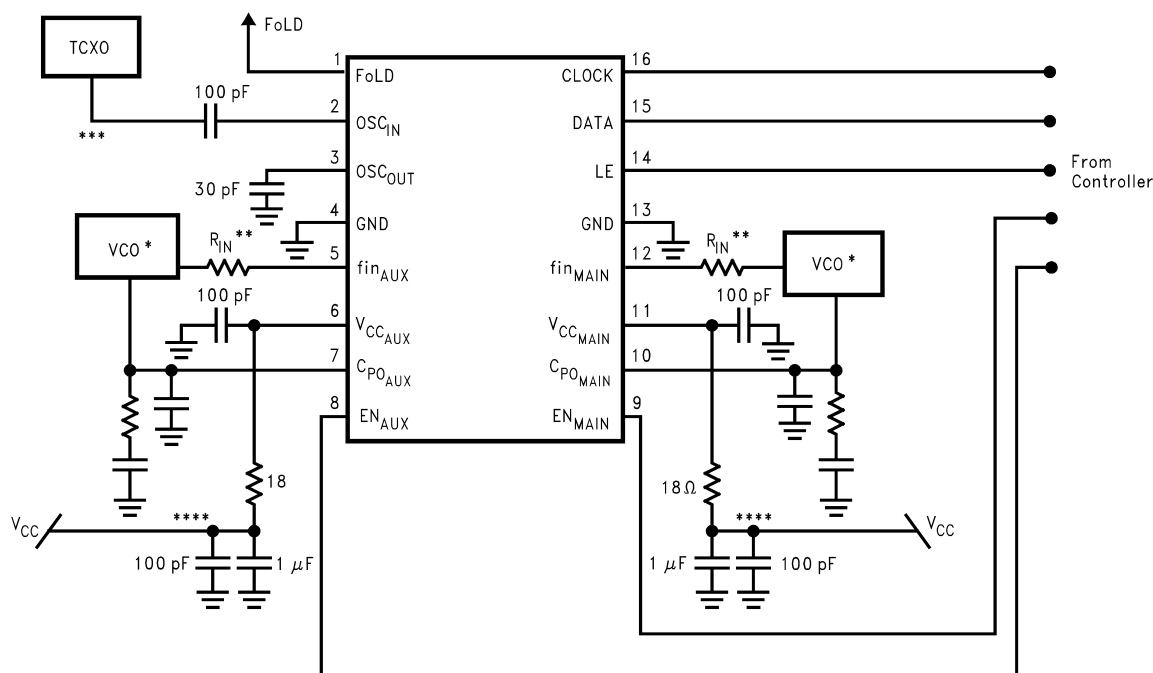

### OPERATIONAL NOTES:

- \* VCO is assumed AC coupled.
- \*\*  $R_{IN}$  increases impedance so that VCO output power is provided to the load rather than the PLL. Typical values are  $10\Omega$  to  $200\Omega$  depending on the VCO power level. The  $f_{in}$  RF impedances range from  $40\Omega$  to  $100\Omega$ . The  $f_{in}$  IF impedances are higher.
- \*\*\*  $50\Omega$  termination is often used on test boards to allow use of external reference oscillator. For most typical products, a CMOS clock is used and no terminating resistor is required.  $OSC_{IN}$  may be AC or DC coupled. AC coupling is recommended because the input circuit provides its own bias. (See Figure 1)

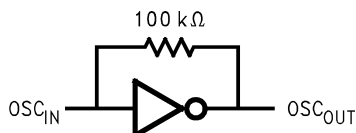

Figure 1.

\*\*\*\* Adding RC filter to the  $V_{CC}$  line is recommended to reduce loop-to-loop noise coupling.

— Proper use of grounds and bypass capacitors is essential to achieve a high level of performance. Crosstalk between pins can be reduced by careful board layout.

— This is a static sensitive device. It should be handled only at static free work stations.

---

**REVISION HISTORY**

<b>Changes from Revision E (April 2013) to Revision F</b>	<b>Page</b>
• Changed layout of National Data Sheet to TI format .....	<a href="#">16</a>

---

## IMPORTANT NOTICE

Texas Instruments Incorporated and its subsidiaries (TI) reserve the right to make corrections, enhancements, improvements and other changes to its semiconductor products and services per JESD46, latest issue, and to discontinue any product or service per JESD48, latest issue. Buyers should obtain the latest relevant information before placing orders and should verify that such information is current and complete. All semiconductor products (also referred to herein as "components") are sold subject to TI's terms and conditions of sale supplied at the time of order acknowledgment.

TI warrants performance of its components to the specifications applicable at the time of sale, in accordance with the warranty in TI's terms and conditions of sale of semiconductor products. Testing and other quality control techniques are used to the extent TI deems necessary to support this warranty. Except where mandated by applicable law, testing of all parameters of each component is not necessarily performed.

TI assumes no liability for applications assistance or the design of Buyers' products. Buyers are responsible for their products and applications using TI components. To minimize the risks associated with Buyers' products and applications, Buyers should provide adequate design and operating safeguards.

TI does not warrant or represent that any license, either express or implied, is granted under any patent right, copyright, mask work right, or other intellectual property right relating to any combination, machine, or process in which TI components or services are used. Information published by TI regarding third-party products or services does not constitute a license to use such products or services or a warranty or endorsement thereof. Use of such information may require a license from a third party under the patents or other intellectual property of the third party, or a license from TI under the patents or other intellectual property of TI.

Reproduction of significant portions of TI information in TI data books or data sheets is permissible only if reproduction is without alteration and is accompanied by all associated warranties, conditions, limitations, and notices. TI is not responsible or liable for such altered documentation. Information of third parties may be subject to additional restrictions.

Resale of TI components or services with statements different from or beyond the parameters stated by TI for that component or service voids all express and any implied warranties for the associated TI component or service and is an unfair and deceptive business practice. TI is not responsible or liable for any such statements.

Buyer acknowledges and agrees that it is solely responsible for compliance with all legal, regulatory and safety-related requirements concerning its products, and any use of TI components in its applications, notwithstanding any applications-related information or support that may be provided by TI. Buyer represents and agrees that it has all the necessary expertise to create and implement safeguards which anticipate dangerous consequences of failures, monitor failures and their consequences, lessen the likelihood of failures that might cause harm and take appropriate remedial actions. Buyer will fully indemnify TI and its representatives against any damages arising out of the use of any TI components in safety-critical applications.

In some cases, TI components may be promoted specifically to facilitate safety-related applications. With such components, TI's goal is to help enable customers to design and create their own end-product solutions that meet applicable functional safety standards and requirements. Nonetheless, such components are subject to these terms.

No TI components are authorized for use in FDA Class III (or similar life-critical medical equipment) unless authorized officers of the parties have executed a special agreement specifically governing such use.

Only those TI components which TI has specifically designated as military grade or "enhanced plastic" are designed and intended for use in military/aerospace applications or environments. Buyer acknowledges and agrees that any military or aerospace use of TI components which have **not** been so designated is solely at the Buyer's risk, and that Buyer is solely responsible for compliance with all legal and regulatory requirements in connection with such use.

TI has specifically designated certain components as meeting ISO/TS16949 requirements, mainly for automotive use. In any case of use of non-designated products, TI will not be responsible for any failure to meet ISO/TS16949.

### Products

Audio	<a href="http://www.ti.com/audio">www.ti.com/audio</a>
Amplifiers	<a href="http://amplifier.ti.com">amplifier.ti.com</a>
Data Converters	<a href="http://dataconverter.ti.com">dataconverter.ti.com</a>
DLP® Products	<a href="http://www.dlp.com">www.dlp.com</a>
DSP	<a href="http://dsp.ti.com">dsp.ti.com</a>
Clocks and Timers	<a href="http://www.ti.com/clocks">www.ti.com/clocks</a>
Interface	<a href="http://interface.ti.com">interface.ti.com</a>
Logic	<a href="http://logic.ti.com">logic.ti.com</a>
Power Mgmt	<a href="http://power.ti.com">power.ti.com</a>
Microcontrollers	<a href="http://microcontroller.ti.com">microcontroller.ti.com</a>
RFID	<a href="http://www.ti-rfid.com">www.ti-rfid.com</a>
OMAP Applications Processors	<a href="http://www.ti.com/omap">www.ti.com/omap</a>
Wireless Connectivity	<a href="http://www.ti.com/wirelessconnectivity">www.ti.com/wirelessconnectivity</a>

### Applications

Automotive and Transportation	<a href="http://www.ti.com/automotive">www.ti.com/automotive</a>
Communications and Telecom	<a href="http://www.ti.com/communications">www.ti.com/communications</a>
Computers and Peripherals	<a href="http://www.ti.com/computers">www.ti.com/computers</a>
Consumer Electronics	<a href="http://www.ti.com/consumer-apps">www.ti.com/consumer-apps</a>
Energy and Lighting	<a href="http://www.ti.com/energy">www.ti.com/energy</a>
Industrial	<a href="http://www.ti.com/industrial">www.ti.com/industrial</a>
Medical	<a href="http://www.ti.com/medical">www.ti.com/medical</a>
Security	<a href="http://www.ti.com/security">www.ti.com/security</a>
Space, Avionics and Defense	<a href="http://www.ti.com/space-avionics-defense">www.ti.com/space-avionics-defense</a>
Video and Imaging	<a href="http://www.ti.com/video">www.ti.com/video</a>

### TI E2E Community

[e2e.ti.com](http://e2e.ti.com)

## Looking for pricing, stock, or lifecycle information?

Click below to explore more details on WIN SOURCE:

 [View LMX1602TM/NOPB on WIN SOURCE](#)

 [Texas Instruments](#) Information

## Optimize Your Supply Chain with WIN SOURCE Solutions

-  Global Sourcing Solution
-  Obsolete Management
-  Cost Control Management
-  Shortage Management
-  Alternative Solution
-  Excess Inventory Management