



# LMX2541 Ultra-Low Noise PLLatinum Frequency Synthesizer With Integrated VCO

## 1 Features

- Multiple Frequency Options Available (See [Device Comparison Table](#))
- Frequencies From 31.6 MHz to 4000 MHz
- Very Low RMS Noise and Spurs
- –225 dBc/Hz Normalized PLL Phase Noise
- Integrated RMS Noise (100 Hz to 20 MHz)
  - 2 mRad (100 Hz to 20 MHz) at 2.1 GHz
  - 3.5 mRad (100 Hz to 20 MHz) at 3.5 GHz
- Ultra Low-Noise Integrated VCO
- External VCO Option (Internal VCO Bypassed)
- VCO Frequency Divider 1 to 63 (All Values)
- Programmable Output Power
- Up to 104-MHz Phase Detector Frequency
- Integrated Low-Noise LDOs
- Programmable Charge Pump Output
- Partially Integrated Loop Filter
- Digital Frequency Shift Keying (FSK) Modulation Pin
- Integrated Reference Crystal Oscillator Circuit
- Hardware and Software Power Down
- FastLock Mode and VCO-Based Cycle Slip Reduction
- Analog and Digital Lock Detect
- 1.6-V Logic Compatibility

## 2 Applications

- Wireless Infrastructure (UMTS, LTE, WiMax)
- Broadband Wireless
- Wireless Meter Reading
- Test and Measurement
- FM Mobile Radio

## 3 Description

The LMX2541 device is an ultra low-noise frequency synthesizer which integrates a high-performance delta-sigma fractional N PLL, a VCO with fully integrated tank circuit, and an optional frequency divider. The PLL offers an unprecedented normalized noise floor of –225 dBc/Hz and can be operated with up to 104 MHz of phase-detector rate (comparison frequency) in both integer and fractional modes. The PLL can also be configured to work with an external VCO.

The LMX2541 integrates several low-noise, high-precision LDOs and output driver matching network to provide higher supply noise immunity and more consistent performance, while reducing the number of external components. When combined with a high-quality reference oscillator, the LMX2541 generates a very stable, ultra low-noise signal.

The LMX2541 is offered in a family of 6 devices with varying VCO frequency range from 1990 MHz up to 4 GHz. Using a flexible divider, the LMX2541 can generate frequencies as low as 31.6 MHz.

The LMX2541 is a monolithic integrated circuit, fabricated in a proprietary BiCMOS process. Device programming is facilitated using a three-wire MICROWIRE interface that can operate down to 1.6 volts. Supply voltage ranges from 3.15 V to 3.45 V. The LMX2541 is available in a 36-pin 6-mm × 6-mm × 0.8-mm WQFN package.

### Device Information<sup>(1)</sup>

PART NUMBER	PACKAGE	VCO FREQUENCY (MHz)
LMX2541SQ2060E	WQFN (36)	1990 - 2240
LMX2541SQ2380E	WQFN (36)	2200 - 2530
LMX2541SQ2690E	WQFN (36)	2490 - 2865
LMX2541SQ3030E	WQFN (36)	2810 - 3230
LMX2541SQ3320E	WQFN (36)	3130 - 3600
LMX2541SQ3740E	WQFN (36)	3480 - 4000

(1) For all available packages, see the orderable addendum at the end of the data sheet.

### System Block Diagram

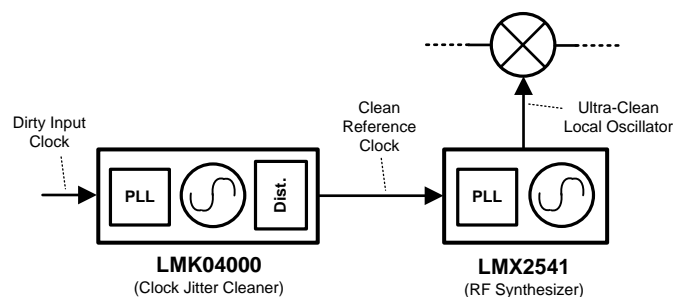



## 5 Device Comparison Table

VCO _DIV	LMX2541SQ2060E		LMX2541SQ2380E		LMX2541SQ2690E		LMX2541SQ3030E		LMX2541SQ3320E		LMX2541SQ3740E	
	Fmin	Fmax	Fmin	Fmax	Fmin	Fmax	Fmin	Fmax	Fmin	Fmax	Fmin	Fmax
1	1990.0	2240.0	2200.0	2530.0	2490.0	2865.0	2810.0	3230.0	3130.0	3600.0	3480.0	4000.0
2	995.0	1120.0	1100.0	1265.0	1245.0	1432.5	1405.0	1615.0	1565.0	1800.0	1740.0	2000.0
3	663.3	746.7	733.3	843.3	830.0	955.0	936.7	1076.7	1043.3	1200.0	1160.0	1333.3
4	497.5	560.0	550.0	632.5	622.5	716.3	702.5	807.5	782.5	900.0	870.0	1000.0
5	398.0	448.0	440.0	506.0	498.0	573.0	562.0	646.0	626.0	720.0	696.0	800.0
6	331.7	373.3	366.7	421.7	415.0	477.5	468.3	538.3	521.7	600.0	580.0	666.7
7	284.3	320.0	314.3	<b>361.4</b>	355.7	<b>409.3</b>	401.4	<b>461.4</b>	447.1	<b>514.3</b>	497.1	<b>571.4</b>
8	248.8	<b>280.0</b>	275.0	316.3	311.3	358.1	351.3	403.8	391.3	450.0	435.0	500.0
...	...	...	...	...	...	...	...	...	...	...	...	...
63	31.6	35.6	34.9	40.2	39.5	45.5	44.6	51.3	49.7	57.1	55.2	63.5

All devices have continuous frequency coverage below a divide value of 8 (7 for most devices) down to their minimum frequency achievable with divide by 63. The numbers in bold show the upper end of this minimum continuous frequency range. For instance, the LMX2541SQ3740E option offers continuous frequency coverage from 55.2 MHz to 571.4 MHz and LMX2541SQ2060E offers continuous frequency coverage from 31.6 MHz to 280 MHz. If using the part in External VCO mode, all parts have roughly the same performance and any option will do.

## 6 Pin Configuration and Functions

**NJK Package  
36-Pin WQFN  
Top View**

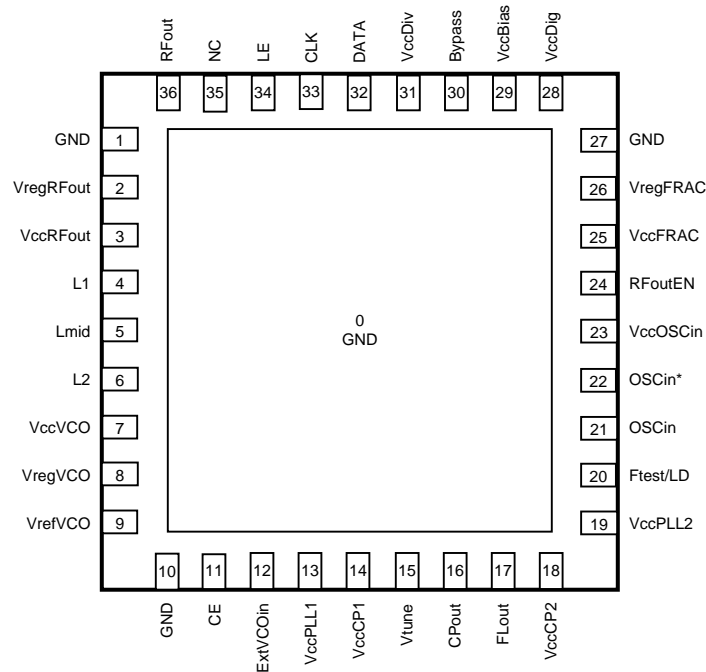

**Pin Functions**

PIN		TYPE	DESCRIPTION
NAME	NO.		
Bypass	30	Bypass	Put a cap to the VccBias pin.
CE	11	CMOS	Chip Enable. The device needs to be programmed for this pin to properly power down the device.
CLK	33	High-Z Input	MICROWIRE clock input. High impedance CMOS input. This pin is used for the digital FSK modulation feature.
CPout	16	Output	Charge pump output.
DATA	32	High-Z Input	MICROWIRE serial data input. High impedance CMOS input.
ExtVCOin	12	RF Input	Optional input for use with an external VCO. This pin should be AC coupled if used or left open if not used.
FLout	17	Output	Fastlock output.
Ftest/LD	20	Output	Software controllable multiplexed CMOS output. Can be used to monitor PLL lock condition.
GND	0	GND	The DAP pad must be grounded.
GND	1	GND	
GND	10	GND	
GND	27	GND	
L1	4	NC	Do not connect this pin.
L2	6	NC	Do not connect this pin.
LE	34	High-Z Input	MICROWIRE Latch Enable input. High impedance CMOS input.
Lmid	5	NC	Do not connect this pin.
NC	35	NC	No connect.
OSCin	21	High-Z Input	Oscillator input signal. If not being used with an external crystal, this input should be AC coupled.

**Pin Functions (continued)**

PIN		TYPE	DESCRIPTION
NAME	NO.		
OSCin*	22	High-Z Input	Complementary oscillator input signal. Can also be used with an external crystal. If not being used with an external crystal, this input should be AC coupled.
RFout	36	RF Output	RF output. Must be AC coupled if used.
RFoutEN	24	Input	Software programmable output enable pin.
VccBias	29	Supply	Supply for Bias circuitry that is for the whole chip.
VccCP1	14	Supply	Power supply for PLL charge pump.
VccCP2	18	Supply	Power supply for PLL charge pump.
VccDig	28	Supply	Supply for digital circuitry, such the MICROWIRE.
VccDiv	31	Supply	Supply for the output divider
VccFRAC	25	Supply (LDO Input)	Power Supply for the PLL fractional circuitry.
VccOSCin	23	Supply	Supply for the OSCin buffer.
VccPLL1	13	Supply	Power supply for PLL.
VccPLL2	19	Supply	Power supply for PLL.
VccRFout	3	Supply (LDO Input)	Supply for the RF output buffer.
VccVCO	7	Supply (LDO Input)	Supply for the VCO.
VregFRAC	26	LDO Output	Regulated power supply used for the fractional delta-sigma circuitry.
VregRFout	2	LDO Output	LDO Output for RF output buffer.
VrefVCO	9	LDO Bypass	LDO Bypass
VregVCO	8	LDO Output	LDO Output for VCO
Vtune	15	High-Z Input	Tuning voltage input to the VCO.

## 7 Specifications

### 7.1 Absolute Maximum Ratings

over operating free-air temperature range (unless otherwise noted) <sup>(1)(2)</sup>

		MIN	MAX	UNIT
V <sub>CC</sub>	Power Supply Voltage	-0.3	3.6	V
V <sub>IN</sub>	Input Voltage to pins other than V <sub>CC</sub> Pins <sup>(3)</sup>	-0.3	(V <sub>CC</sub> + 0.3)	V
T <sub>L</sub>	Lead Temperature (solder 4 sec.)		260	°C
T <sub>stg</sub>	Storage Temperature	-65	150	°C

- (1) Stresses beyond those listed under *Absolute Maximum Ratings* may cause permanent damage to the device. These are stress ratings only, which do not imply functional operation of the device at these or any other conditions beyond those indicated under *Recommended Operating Conditions*. Exposure to absolute-maximum-rated conditions for extended periods may affect device reliability.
- (2) If Military/Aerospace specified devices are required, please contact the Texas Instruments Sales Office/Distributors for availability and specifications.
- (3) Never to exceed 3.6 V.

### 7.2 ESD Ratings

		VALUE	UNIT
V <sub>(ESD)</sub>	Electrostatic discharge		V
	Human body model (HBM), per ANSI/ESDA/JEDEC JS-001 <sup>(1)</sup>	±2500	
	Charged-device model (CDM), per JEDEC specification JESD22-C101 <sup>(2)</sup>	±1750	
	Machine model (MM)	±400	

- (1) JEDEC document JEP155 states that 500-V HBM allows safe manufacturing with a standard ESD control process.
- (2) JEDEC document JEP157 states that 250-V CDM allows safe manufacturing with a standard ESD control process.

### 7.3 Recommended Operating Conditions

		MIN	NOM	MAX	UNIT
V <sub>CC</sub>	Power Supply Voltage (All V <sub>CC</sub> Pins)	3.15	3.3	3.45	V
T <sub>A</sub>	Ambient Temperature	-40		85	°C

### 7.4 Thermal Information

THERMAL METRIC <sup>(1)</sup>		LMX2541 SQ2060E	LMX2541 SQ2060E	LMX2541 SQ2060E	UNIT
		9 Thermal Vias <sup>(2)</sup>	13 Thermal Vias <sup>(3)</sup>	16 Thermal Vias <sup>(4)</sup>	
R <sub>θJA</sub>	Junction-to-ambient thermal resistance	31.7	30.3	29.8	°C/W
ψ <sub>JT</sub>	Junction-to-top characterization parameter	7.3	7.3	7.3	

- (1) For more information about traditional and new thermal metrics, see the *IC Package Thermal Metrics* application report, [SPRA953](#).
- (2) Recommended for Most Reliable Solderability.
- (3) Compromise Between Solderability, Heat Dissipation, and Fractional Spurs.
- (4) Recommended for Optimal Heat Dissipation and Fractional Spurs.

## 7.5 Electrical Characteristics

(3.15 V ≤ V<sub>CC</sub> ≤ 3.45 V, -40°C ≤ T<sub>A</sub> ≤ 85 °C; except as specified. Typical values are at V<sub>CC</sub> = 3.3 V, 25 °C.)

PARAMETER		TEST CONDITIONS		MIN	TYP	MAX	UNIT
<b>CURRENT CONSUMPTION</b>							
I <sub>CC</sub>	Entire Chip Supply Current with all blocks enabled	Default Power Mode <sup>(1)</sup>	VCO_DIV>1		170	204	mA
			VCO_DIV=1		130	156	
I <sub>PLL</sub>	Current for External VCO Mode	RFoutEN = LOW			72	94	mA
I <sub>DIV</sub>	Current for Divider Only Mode	VCO_DIV >1 Default Power Mode <sup>(1)</sup>			84	110	mA
I <sub>CC</sub> PD	Power Down Current	CE = 0 V, Device Initialized			100	250	μA
<b>OSCILLATOR (NORMAL MODE OPERATION WITH XO=0)</b>							
I <sub>IH</sub> OSC <sub>in</sub>	Oscillator Input High Current for OSCin and OSCin*	V <sub>IH</sub> = 2.75 V				300	μA
I <sub>IL</sub> OSC <sub>in</sub>	Oscillator Input Low Current for OSCin and OSCin* pins	V <sub>IL</sub> = 0			-100		μA
f <sub>OSCin</sub>	OSCin Frequency Range <sup>(2)</sup>	OSC_2X = 1			5	52	MHz
		OSC_2X = 0	MODE = 0		5	700	
			MODE = 1		5	900	
dv <sub>OSCin</sub>	Slew Rate	<sup>(2)</sup>			150		V/μs
v <sub>OSCin</sub>	Oscillator Sensitivity	dv <sub>OSCin</sub> ≥ 150 V/μs		Single-Ended	0.2	2.0	V <sub>pp</sub>
				Differential	0.4	3.1	
<b>OSCILLATOR (CRYSTAL MODE WITH XO=1)</b>							
f <sub>XTAL</sub>	Crystal Frequency Range	V <sub>IH</sub> = 2.75 V			5	20	MHz
ESR <sub>XTAL</sub>	Crystal Equivalent Series Resistance	This a requirement for the crystal, not a characteristic of the LMX2541.				100	Ω
P <sub>XTAL</sub>	Power Dissipation in Crystal	This requirement is for the crystal, not a characteristic of the LMX2541.			200		μW
C <sub>OSCin</sub>	Input Capacitance of OSCin				6		pF
<b>PLL</b>							
f <sub>PD</sub>	Phase Detector Frequency					104	MHz
I <sub>CPout</sub>	Charge Pump Output Current Magnitude	CPG = 1X			100		μA
		CPG = 2X			200		
		CPG = 3X			300		
		...			...		
		CPG=32X			3200		
I <sub>CPout</sub> TR	CP TRI-STATE Current	0.4 V < V <sub>CPout</sub> < V <sub>CC</sub> - 0.4			1	5	nA
I <sub>CPout</sub> M	Charge Pump Sink vs. Source Mismatch	V <sub>CPout</sub> = V <sub>CC</sub> / 2 T <sub>A</sub> = 25°C			3%	10%	
I <sub>CPout</sub> V	Charge Pump Current vs. CP Voltage Variation	0.4 V < V <sub>CPout</sub> < V <sub>CC</sub> - 0.4 T <sub>A</sub> = 25°C			4%		
I <sub>CPout</sub> T	CP Current vs. Temperature Variation	V <sub>CPout</sub> = V <sub>CC</sub> / 2			8%		
LN(f) <sup>(3)</sup>	Normalized PLL 1/f Noise LN <sub>PLL_flicker</sub> (10 kHz)	CPG = 1X			-116		dBc/Hz
		CPG = 32X			-124.5		
	Normalized PLL Noise Floor LN <sub>PLL_flat</sub> (1 Hz)	CPG = 1X			-220.8		dBc/Hz
		CPG = 32X			-225.4		

(1) The LMX2541 RFout power level is programmable with the program words of VCOGAIN, OUTTERM, and DIVGAIN. Changing these words can change the output power of the VCO as well as the current consumption of the output buffer. For the purpose of consistency in electrical specifications, "Default Power Mode" is defined to be the settings of VCOGAIN = OUTTERM = DIVGAIN = 12.

(2) Not tested in production. Specified by characterization. OSCin is tested only to 400 MHz.

(3) See [Application and Implementation](#) for more details on these parameters.

**Electrical Characteristics (continued)**

 (3.15 V ≤ V<sub>CC</sub> ≤ 3.45 V, -40°C ≤ T<sub>A</sub> ≤ 85 °C; except as specified. Typical values are at V<sub>CC</sub> = 3.3 V, 25 C.)

PARAMETER		TEST CONDITIONS	MIN	TYP	MAX	UNIT
f <sub>ExtVCOin</sub>	PLL Input Frequency	RFout Buffer Enabled and VCO_DIV > 1	400		4000	MHz
		RFout Buffer Disabled and VCO_DIV = 1	400		6000	
P <sub>ExtVCOin</sub>	PLL Input Sensitivity ( <sup>(2)</sup> applies to Max Limit Only)	f <sub>ExtVCOin</sub> ≤ 4 GHz	-15		10	dBm
		f <sub>ExtVCOin</sub> > 4 GHz	-5		10	
<b>VCO SPECIFICATIONS</b>						
f <sub>VCO</sub>	Internal VCO Frequency Range	Mode = Full Chip Mode This is the frequency before the VCO divider.	2060E	1990	2240	MHz
			2380E	2200	2530	
			2690E	2490	2865	
			3030E	2810	3230	
			3320E	3130	3600	
			3740E	3480	4000	
ΔT <sub>CL</sub>	Maximum Allowable Temperature Drift for Continuous Lock	( <sup>(2)</sup> , <sup>(4)</sup> )	125			°C
P <sub>RFout</sub>	RF Output Power	Maximum Frequency Default Power Mode VCO_DIV=1	2060E	3.5		dBm
			2380E	2.8		
			2690E	1.6		
			3030E	1.2		
			3320E	0.2		
			3740E	-0.3		
ΔP <sub>RFout</sub>	Change in Output Power	Fixed Temperature with 100 MHz frequency change at the output		0.3		dB
		Fixed frequency with a change over the entire temperature range		0.4		
K <sub>Vtune</sub>	Fine Tuning Sensitivity	The lower number in the range applies when the VCO is at its lowest frequency and the higher number applies when the VCO is at its highest frequency. A linear approximation can be used for frequencies between these two cases.	2060E	13 - 23		MHz/V
			2380E	16 - 30		
			2690E	17 - 32		
			3030E	20 - 37		
			3320E	21 - 37		
			3740E	24 - 42		
HS <sub>RFout</sub>	Second Harmonic ( <sup>(5)</sup> )	Default Power Mode ( <sup>(1)</sup> ) 50 Ω Load	VCO_DIV = 2	-20		dBc
			VCO_DIV = 3	-20		
DE <sub>RFout</sub>	Duty Cycle Error ( <sup>(5)</sup> )	Default Power Mode ( <sup>(1)</sup> ) 50 Ω Load	VCO_DIV = 2	3%		
			VCO_DIV = 3	3%		
PSH <sub>VCO</sub>	VCO Frequency Pushing	C <sub>VregVCO</sub> = 4.7 μF, Open Loop		600		kHz/V
PUL <sub>VCO</sub>	VCO Frequency Pulling	VSWR 1.7 to 1 (6 dB Pad)	VCO_DIV = 1	±800		kHz
			VCO_DIV > 1	±60		

(4) Maximum Allowable Temperature Drift for Continuous Lock is how far the temperature can drift in either direction from the value it was at the time that the R0 register was last programmed, and still have the device stay in lock. The action of programming the R0 register, even to the same value, activates a frequency calibration routine. This implies that the device will work over the entire frequency range, but if the temperature drifts more than the maximum allowable drift for continuous lock, then it will be necessary to reload the R0 register to ensure that it stays in lock. Regardless of what temperature the device was initially programmed at, the temperature can never drift outside the frequency range of -40°C ≤ T<sub>A</sub> ≤ 85°C without violating specifications.

(5) The duty cycle error (DE) and second harmonic (HS) are theoretically related by the equation HS = 10·log<sub>10</sub> |2π·DE| - 6 dB. A square wave with 3% duty cycle theoretically has a second harmonic of -20 dBc.

**Electrical Characteristics (continued)**

(3.15 V ≤ V<sub>CC</sub> ≤ 3.45 V, -40°C ≤ T<sub>A</sub> ≤ 85 °C; except as specified. Typical values are at V<sub>CC</sub> = 3.3 V, 25 C.)

PARAMETER		TEST CONDITIONS		MIN	TYP	MAX	UNIT
σ <sub>φ</sub>	RMS Phase Error	Integration Bandwidth = 100 Hz to 20 MHz Middle VCO Frequency 100 MHz Wenzel Crystal Reference Integer Mode Optimized Loop Bandwidth	2060E		1.6		mRad
			2380E		1.8		
			2690E		2.1		
			3030E		2.1		
			3320E		2.3		
			3740E		2.6		
<b>VCO PHASE NOISE<sup>(6)</sup></b>							
L(f) <sub>Fout</sub>	Phase Noise 2060E	f <sub>RFout</sub> = Min VCO Frequency	10-kHz Offset		-89.7		dBc/Hz
			100-kHz Offset		-113.7		
			1-MHz Offset		-134.9		
			10-MHz Offset		-155.4		
			20-MHz Offset		-160.3		
		f <sub>RFout</sub> = Max VCO Frequency	10-kHz Offset		-86.5		
			100-kHz Offset		-111.4		
			1-MHz Offset		-132.8		
			10-MHz Offset		-153.4		
			20-MHz Offset		-158.5		
L(f) <sub>Fout</sub>	Phase Noise 2380E	f <sub>RFout</sub> = Min VCO Frequency	10-kHz Offset		-87.9		dBc/Hz
			100-kHz Offset		-112.7		
			1-MHz Offset		-133.8		
			10-MHz Offset		-154.2		
			20-MHz Offset		-159.5		
		f <sub>RFout</sub> = Max VCO Frequency	10-kHz Offset		-83.4		
			100-kHz Offset		-109.1		
			1-MHz Offset		-130.8		
			10-MHz Offset		-151.8		
			20-MHz Offset		-157.5		
L(f) <sub>Fout</sub>	Phase Noise 2690E	f <sub>RFout</sub> = Min VCO Frequency	10-kHz Offset		-86.9		dBc/Hz
			100-kHz Offset		-111.8		
			1-MHz Offset		-133.3		
			10-MHz Offset		-154.2		
			20-MHz Offset		-159.4		
		f <sub>RFout</sub> = Max VCO Frequency	10-kHz Offset		-82.3		
			100-kHz Offset		-108.4		
			1-MHz Offset		-130.3		
			10-MHz Offset		-151.1		
			20-MHz Offset		-156.7		

(6) The VCO phase noise is measured assuming that the loop bandwidth is sufficiently narrow that the VCO noise dominates. The phase noise is measured with AC\_TEMP\_COMP = 5 and the device is reloaded at each test frequency. The typical performance characteristics section shows how the VCO phase noise varies over temperature and frequency.

**Electrical Characteristics (continued)**

 (3.15 V ≤ V<sub>CC</sub> ≤ 3.45 V, -40°C ≤ T<sub>A</sub> ≤ 85 °C; except as specified. Typical values are at V<sub>CC</sub> = 3.3 V, 25 C.)

PARAMETER		TEST CONDITIONS	MIN	TYP	MAX	UNIT
L(f) <sub>Fout</sub>	Phase Noise 3030E	f <sub>RFout</sub> = Min VCO Frequency	10-kHz Offset	-86.1		dBc/Hz
			100-kHz Offset	-110.5		
			1-MHz Offset	-132.0		
			10-MHz Offset	-152.2		
			20-MHz Offset	-157.1		
		f <sub>RFout</sub> = Max VCO Frequency	10-kHz Offset	-82.2		
			100-kHz Offset	-107.7		
			1-MHz Offset	-129.4		
			10-MHz Offset	-150.5		
			20-MHz Offset	-156.1		
L(f) <sub>Fout</sub>	Phase Noise 3320E	f <sub>RFout</sub> = Min VCO Frequency	10-kHz Offset	-84.1		dBc/Hz
			100-kHz Offset	-109.1		
			1-MHz Offset	-130.7		
			10-MHz Offset	-151.6		
			20-MHz Offset	-156.9		
		f <sub>RFout</sub> = Max VCO Frequency	10-kHz Offset	-82.0		
			100-kHz Offset	-107.0		
			1-MHz Offset	-128.5		
			10-MHz Offset	-149.6		
			20-MHz Offset	-155.2		
L(f) <sub>Fout</sub>	Phase Noise 3740E	f <sub>RFout</sub> = Min VCO Frequency	10-kHz Offset	-83.9		dBc/Hz
			100-kHz Offset	-108.3		
			1-MHz Offset	-129.9		
			10-MHz offset	-150.6		
			20-MHz Offset	-156.5		
		f <sub>RFout</sub> = Max VCO Frequency	10-kHz Offset	-81.6		
			100-kHz Offset	-106.5		
			1-MHz Offset	-127.7		
			10-MHz Offset	-148.6		
			20-MHz Offset	-154.2		
<b>DIGITAL INTERFACE (DATA, CLK, LE, CE, Ftest/LD, FLout,RFoutEN)</b>						
V <sub>IH</sub>	High-Level Input Voltage		1.6		V <sub>CC</sub>	V
V <sub>IL</sub>	Low-Level Input Voltage				0.4	V
I <sub>IH</sub>	High-Level Input Current	V <sub>IH</sub> = 1.75, XO = 0	-5		5	μA
I <sub>IL</sub>	Low-Level Input Current	V <sub>IL</sub> = 0 V, XO = 0	-5		5	μA
V <sub>OH</sub>	High-Level Output Voltage	I <sub>OH</sub> = 500 μA	2			V
V <sub>OL</sub>	Low-Level Output Voltage	I <sub>OL</sub> = -500 μA		0	0.4	V
I <sub>Leak</sub>	Leakage Current	Ftest/LD and FLout Pins Only	-5		5	μA

## 7.6 Timing Requirements

			MIN	NOM	MAX	UNIT
$t_{CE}$	Clock to Enable Low Time	See Figure 1	25			ns
$t_{CS}$	Data to Clock Set Up Time	See Figure 1	25			ns
$t_{CH}$	Data to Clock Hold Time	See Figure 1	20			ns
$t_{CWH}$	Clock Pulse Width High	See Figure 1	25			ns
$t_{CWL}$	Clock Pulse Width Low	See Figure 1	25			ns
$t_{CES}$	Enable to Clock Set Up Time	See Figure 1	25			ns
$t_{EWH}$	Enable Pulse Width High	See Figure 1	25			ns

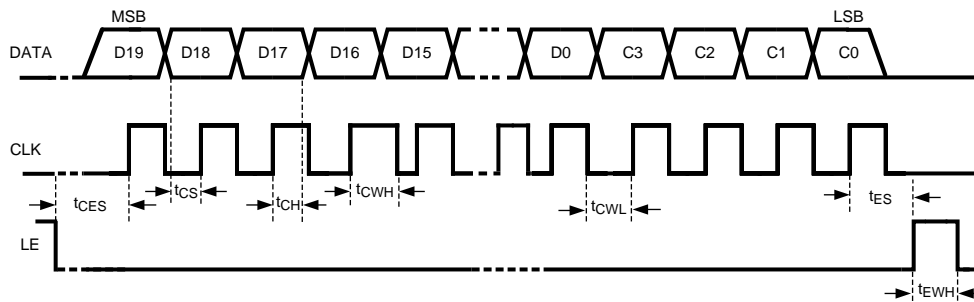

Figure 1. Serial Data Timing Diagram

## 7.7 Typical Characteristics

### 7.7.1 Not Ensured Characteristics

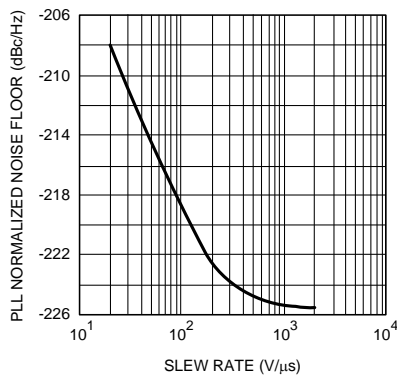

Figure 2. PLL Normalized Noise Floor vs OSCin Slew Rate ( $K_{PD} = 32X$ )

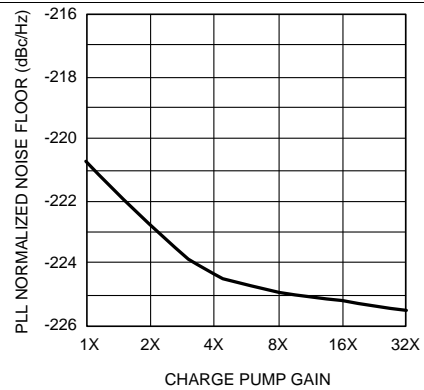

Figure 3. PLL Normalized Noise Floor vs Charge Pump Gain (Slew Rate = 2000 V/μs)

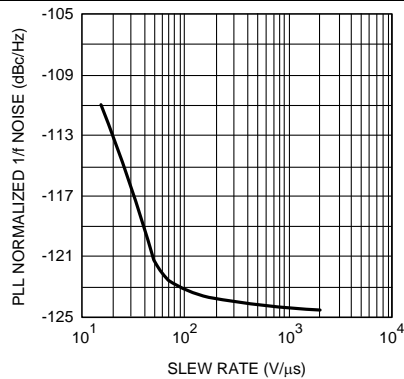

Figure 4. PLL Normalized 1/f Noise vs OSCin Slew Rate ( $K_{PD} = 32X$ )

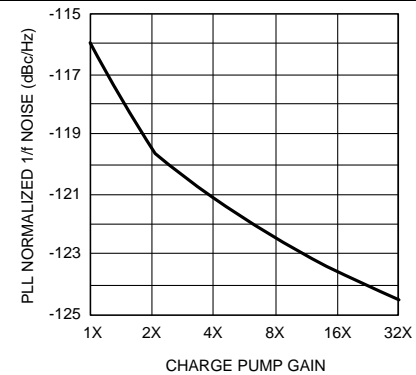
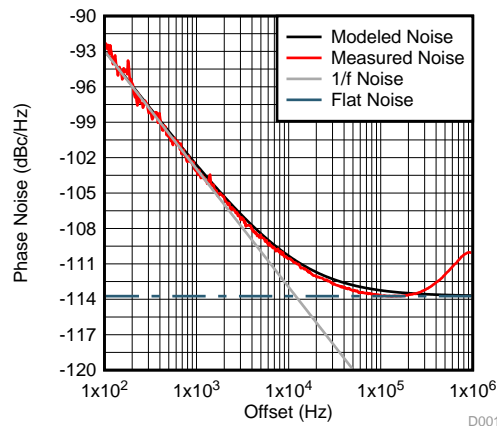

Figure 5. PLL Normalized 1/f Noise vs Charge Pump Gain (Slew Rate = 2000 V/μs)



See [Phase Noise Measurement Test Setup](#)

Figure 6. PLL 1/f and Noise Floor Measurement of the LMX2541SQ3740E

Not Ensured Characteristics (continued)

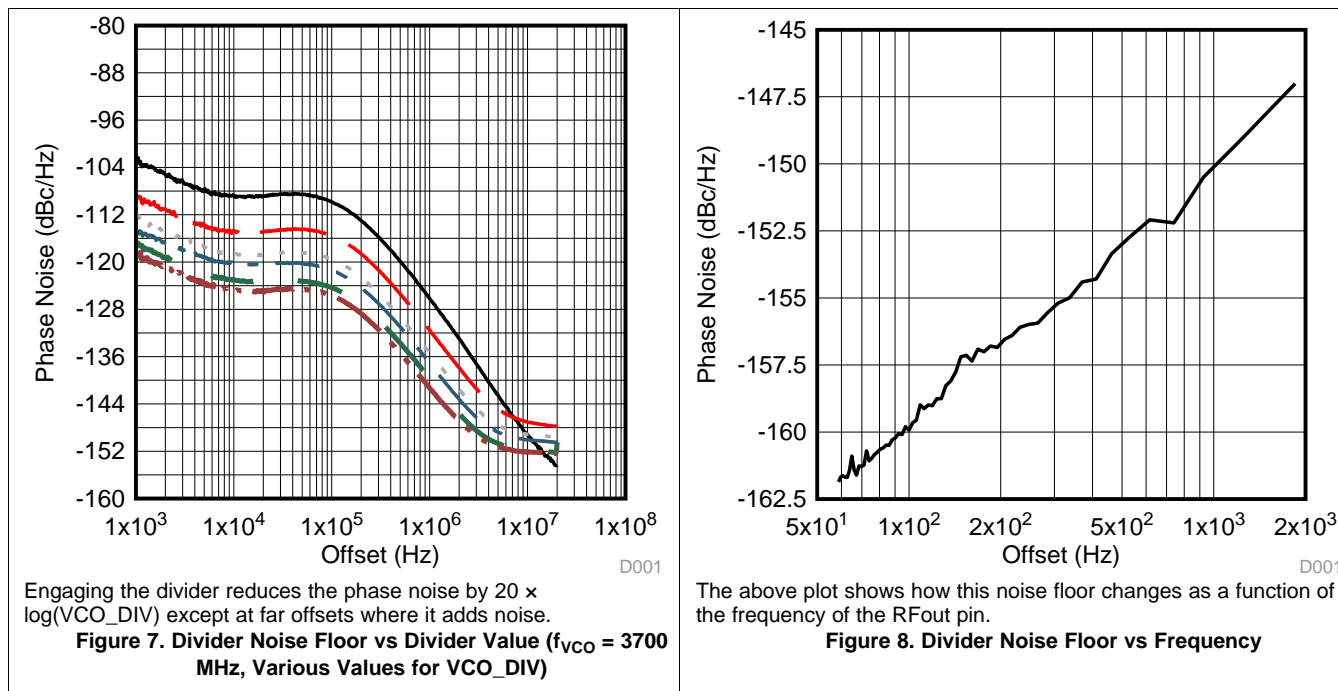

**Table 1. Relative VCO Phase Noise Over Temperature Drift (AC\_TEMP\_COMP = 24, Vcc = 3.3 V)<sup>(1)</sup>**

TEMPERATURE		PHASE NOISE CHANGE IN CELSIUS FOR VARIOUS OFFSETS				
LOCK	CURRENT	10 kHz	100 kHz	1 MHz	10 MHz	20 MHz
-40	-40	+0.4	-2.0	-1.6	-1.8	-1.6
-40	25	+0.3	+0.5	+0.5	+0.5	+0.4
-40	85	+0.9	+2.0	+2.4	+2.5	+2.3
25	-40	+0.2	-2.2	-1.7	-2.0	-1.8
25	25	This is the default condition to which these other numbers are normalized to.				
25	85	+0.6	+1.5	+2.0	+2.0	+1.9
85	-40	+0.2	-2.2	-1.7	-1.9	-1.8
85	25	+0.2	+0.2	+0.3	+0.2	+0.2
85	85	+0.6	+1.8	+2.2	+2.3	+2.1

(1) The table shows the typical degradation for VCO phase noise when the VCO is locked at one temperature and the temperature is allowed to drift to another temperature. A negative value indicates a phase noise improvement.

### 7.7.2 Output Power in Bypass Mode

The following plots show the trends in output power as a function of temperature, voltage, and frequency. For states where VCOGAIN and OUTTERM are not 12, the table below shows how the output power is modified based on these programmable settings. The measurement of the output power is sensitive to the test circuit. All the numbers in the electrical specifications and typical performance curves were obtained from a characterization setup that accommodate temperature testing and changing of parts. In a more optimized setup the measured RF output power is typically on the order of 1.5 to 2.4 dB higher.

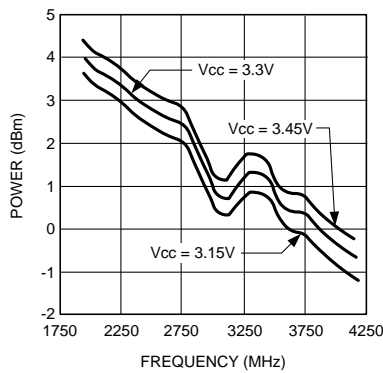

Figure 9. Output Power vs Voltage (VCO\_DIV = 1, VCOGAIN = 12, OUTTERM = 12, T<sub>A</sub> = 25°C)

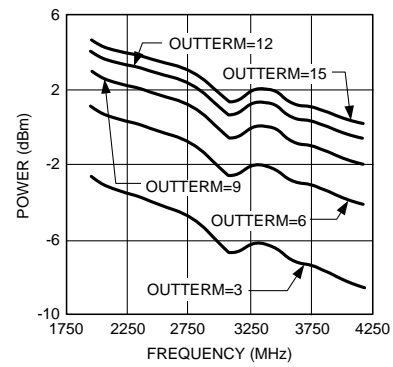

Figure 10. Output Power vs OUTTERM and FREQUENCY (VCO\_DIV = 1, T<sub>A</sub> = 25 °C, Vcc = 3.3 V, VCOGAIN = 12)

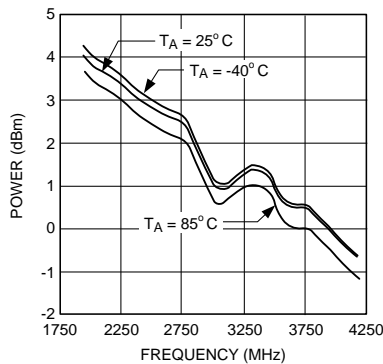

Figure 11. Output Power vs Temperature (VCO\_DIV = 1, VCOGAIN = 12, OUTTERM = 12, Vcc = 3.3 V)

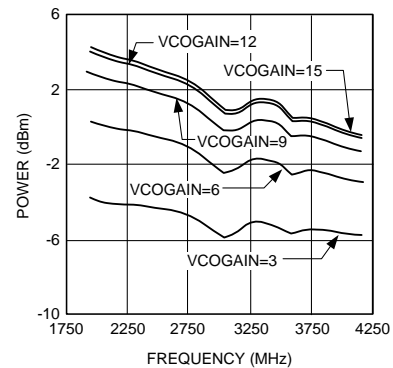

Figure 12. Output Power vs VCOGAIN and FREQUENCY (VCO\_DIV = 1, T<sub>A</sub> = 25 °C, Vcc = 3.3 V, OUTTERM = 12)

Table 2. Change in Output Power in Bypass Mode as a Function of VCOGAIN and OUTTERM

		VCOGAIN				
		3	6	9	12	15
OUTTERM	3	-9.7	-8.4	-7.9	-7.8	-7.9
	6	-6.6	-4.5	-3.6	-3.4	-3.6
	9	-5.7	-3.1	-1.7	-1.3	-1.3
	12	-5.4	-2.5	-0.8	+0.0	+0.1
	15	-5.3	-2.2	-0.3	+0.8	+1.1

### 7.7.3 Output Power in Divided Mode

The measurement of the output power is sensitive to the test circuit. All the numbers in the electrical specifications and typical performance curves were obtained from a characterization setup that accommodate temperature testing and changing of parts. In a more optimized setup the measured RF output power is typically on the order of 1.5 to 2.4 dB higher.

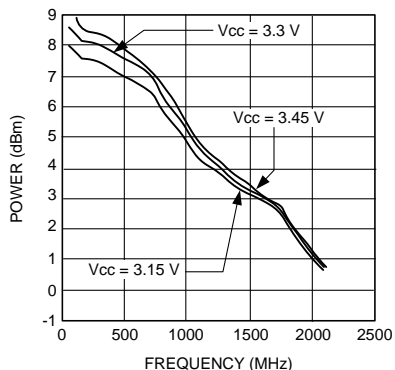

Figure 13. Output Power vs Voltage (VCO\_DIV > 1, DIVGAIN = 12, OUTTERM = 12, T<sub>A</sub> = 25°C)

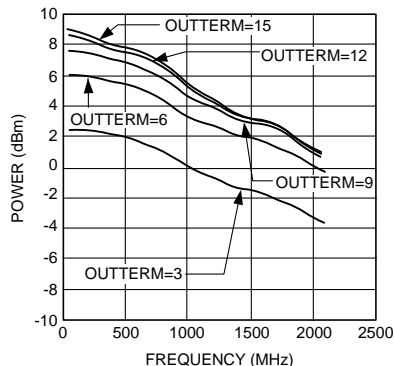

Figure 14. Output Power vs OUTTERM and FREQUENCY (VCO\_DIV > 1, T<sub>A</sub> = 25 °C, V<sub>CC</sub> = 3.3 V, DIVGAIN = 12)

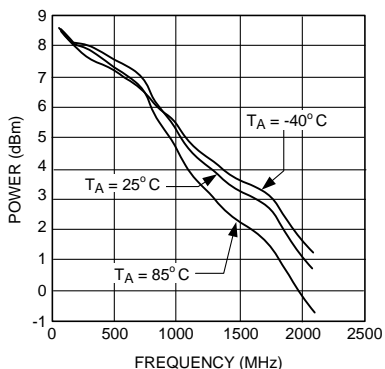

Figure 15. Output Power vs Temperature ( VCO\_DIV > 1, DIVGAIN = OUTTERM = 12, V<sub>CC</sub> = 3.3 V)

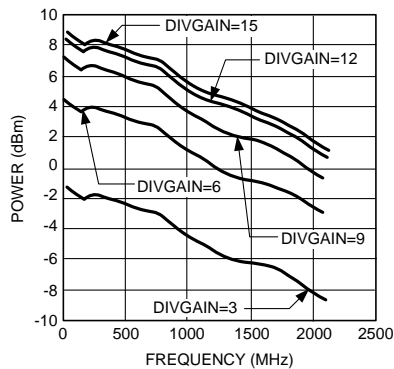

Figure 16. Output Power vs DIVGAIN and FREQUENCY (VCO\_DIV > 1, T<sub>A</sub> = 25 °C, V<sub>CC</sub> = 3.3 V, OUTTERM = 12)

Table 3. Change in Output Power in Divided Mode as a Function of DIVGAIN and OUTTERM<sup>(1)</sup>

		DIVGAIN				
		3	6	9	12	15
OUTTERM	3	-10.2	-6.1	-5.7	-5.5	-5.5
	6	-9.8	-4.4	-2.4	-2.1	-2.0
	9	-9.8	-4.3	-1.5	-0.7	-0.5
	12	-9.9	-4.3	-1.4	+0.0	+0.2
	15	-9.9	-4.4	-1.4	+0.3	+0.7

(1) The table shows the RELATIVE output power to the case of VCOGAIN = OUTTERM = 12.

### 7.7.4 RFout Output Impedance

The impedance of the RFout pin varies as a function of frequency, VCO\_DIV, OUTTERM, VCOGAIN, DIVGAIN, and frequency. When in bypass mode (VCO\_DIV = 1), the DIVGAIN word has no impact on the output impedance. When in divided mode (VCO\_DIV > 1), the VCOGAIN has no impact on the output impedance. This graphic shows how the input impedance varies as a function of frequency for both the bypass and divided cases.

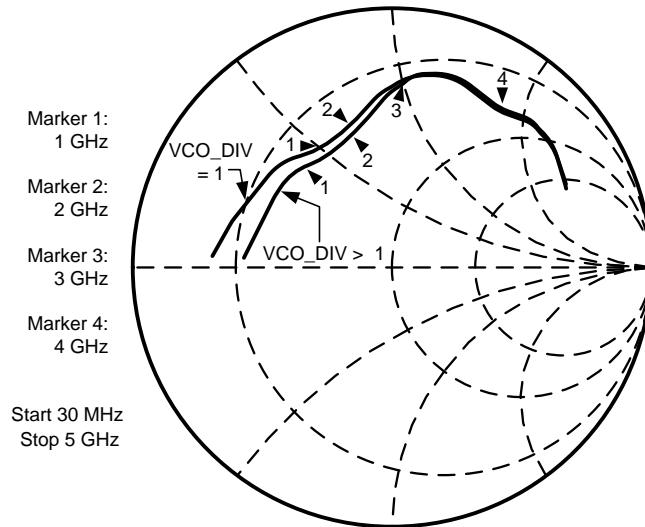

Figure 17. RFout Output Impedance

Table 4. RFout Output Impedance vs. VCOGAIN (Bypass Mode)<sup>(1)</sup>

Freq. (MHz)	VCOGAIN=3		VCOGAIN=6		VCOGAIN=9		VCOGAIN=12		VCOGAIN=15	
	REAL	IMAGINARY	REAL	IMAGINARY	REAL	IMAGINARY	REAL	IMAGINARY	REAL	IMAGINARY
50	3.8	2.1	5.5	1.9	7.3	1.8	9.5	1.7	10.1	1.7
100	4.8	4.1	6.1	3.9	7.8	3.7	9.8	3.6	10.3	3.6
200	5.4	5.7	6.8	6.0	8.7	6.3	10.9	6.5	11.4	6.6
400	5.5	9.4	7.5	10.0	9.8	10.6	12.4	11.0	13.1	11.0
600	5.8	15.1	8.1	15.4	10.7	15.7	13.7	15.7	14.5	15.6
800	7.0	20.7	9.6	20.8	12.6	20.8	15.8	20.3	16.7	20.1
1000	9.2	26.3	12.1	26.1	15.4	25.6	19.0	24.6	19.8	24.1
1200	10.7	28.6	13.4	27.9	16.3	26.9	19.3	25.5	20.0	25.0
1400	12.2	30.9	14.7	29.7	17.1	28.2	19.7	26.4	20.2	25.9
1600	13.7	33.2	15.9	31.5	18.0	29.5	20.1	27.4	20.5	26.8
1800	15.2	35.5	17.2	33.3	18.8	30.8	20.5	28.3	20.7	27.7
2000	14.5	39.5	16.4	37.4	17.9	35.0	19.6	32.5	19.8	31.9
2200	15.6	42.9	17.4	40.7	18.7	38.2	20.3	35.6	20.4	35.0
2400	14.2	47.6	16.0	45.3	17.4	42.8	19.0	40.1	19.2	39.4
2600	12.2	51.3	14.1	48.7	15.6	46.5	17.2	43.5	17.3	42.5
2800	11.5	57.9	13.7	55.3	15.3	52.4	17.0	49.0	17.1	48.3
3000	10.6	67.1	13.1	64.0	14.8	60.5	16.3	56.5	16.4	55.7
3200	13.1	77.3	15.7	73.2	17.3	69.0	18.4	64.2	18.4	63.3
3400	17.6	88.1	20.0	82.8	21.1	77.4	21.7	71.8	21.5	70.8
3600	29.0	96.0	30.6	90.2	30.9	83.6	30.2	76.7	29.8	75.6
3800	38.2	99.4	38.0	94.4	36.4	87.3	34.1	80.5	33.4	79.4

(1) This is for the VCO divider in bypass mode (VCO\_DIV=1) and the RFout pin powered up. OUTTERM was set to 12.

**RFout Output Impedance (continued)**
**Table 4. RFout Output Impedance vs. VCOGAIN (Bypass Mode)<sup>(1)</sup> (continued)**

Freq. (MHz)	VCOGAIN=3		VCOGAIN=6		VCOGAIN=9		VCOGAIN=12		VCOGAIN=15	
	REAL	IMAGINARY	REAL	IMAGINARY	REAL	IMAGINARY	REAL	IMAGINARY	REAL	IMAGINARY
4000	43.5	106.0	41.6	99.0	38.9	92.0	35.5	85.1	34.8	83.7
4200	48.0	119.3	45.9	109.8	43.1	101.9	37.2	94.2	36.0	93.0
4400	62.4	137.9	56.4	126.6	49.8	117.6	42.3	109.5	40.8	108.3
4600	87.0	149.4	76.0	138.1	65.4	129.5	54.3	122.2	52.3	121.2
4800	128.1	153.7	109.7	145.6	93.0	140.1	76.7	135.9	74.0	135.5
5000	168.1	134.7	145.4	135.5	124.9	138.0	105.4	141.1	102.4	141.9

**Table 5. RFout Output Impedance vs. OUTTERM (Bypass Mode)<sup>(1)</sup>**

Freq. (MHz)	OUTTERM=3		OUTTERM=6		OUTTERM=9		OUTTERM=12		TERM=15	
	REAL	IMAGINARY	REAL	IMAGINARY	REAL	IMAGINARY	REAL	IMAGINARY	REAL	IMAGINARY
50	27.9	1.6	16.2	1.9	12.3	1.8	9.5	1.7	7.8	1.7
100	28.5	2.8	16.7	3.6	12.7	3.6	9.8	3.6	8.0	3.5
200	29.2	3.8	18.1	5.9	14.0	6.3	10.9	6.5	9.0	6.6
400	28.8	5.7	19.2	9.5	15.3	10.3	12.4	11.0	10.6	11.2
600	28.8	8.8	20.4	13.7	16.5	14.9	13.7	15.7	11.9	16.0
800	29.1	11.7	22.5	17.5	18.7	19.2	15.8	20.3	14.0	20.8
1000	28.6	13.4	22.8	19.2	19.3	21.2	16.5	22.5	14.6	23.1
1200	28.0	15.0	23.1	20.9	19.8	23.2	17.1	24.7	15.2	25.4
1400	27.5	16.7	23.3	22.7	20.4	25.2	17.7	26.9	15.8	27.7
1600	27.0	18.4	23.6	24.4	20.9	27.2	18.4	29.0	16.5	30.0
1800	26.4	20.1	23.9	26.1	21.4	29.2	19.0	31.2	17.1	32.3
2000	25.9	21.8	24.1	27.9	22.0	31.1	19.6	33.4	17.7	34.6
2200	25.3	23.5	24.4	29.6	22.5	33.1	20.3	35.6	18.3	36.9
2400	23.1	26.9	22.9	33.2	21.3	37.1	19.0	40.1	17.0	41.8
2600	20.1	29.3	20.5	35.4	19.3	39.6	17.2	42.9	15.1	44.9
2800	18.5	34.2	19.6	40.4	18.8	45.0	17.0	49.0	14.8	51.6
3000	16.6	40.6	18.1	46.9	17.8	51.9	16.3	56.5	14.3	59.7
3200	16.5	47.0	18.9	53.4	19.3	58.9	18.4	64.2	16.7	68.2
3400	17.1	53.8	20.4	60.1	21.8	65.8	21.7	71.8	20.4	76.6
3600	20.8	59.4	25.4	65.0	28.3	70.5	30.2	76.8	30.3	82.5
3800	22.0	64.9	27.3	69.7	31.1	74.6	34.1	80.5	35.4	86.1
4000	23.0	70.0	28.1	74.9	32.1	80.0	35.5	86.4	37.6	92.0
4200	23.7	77.9	28.6	82.8	32.8	87.7	37.0	94.2	39.9	100.9
4400	23.7	93.2	30.1	98.0	35.4	102.9	42.3	109.4	47.8	116.6
4600	27.3	107.4	36.6	112.0	44.8	116.3	54.3	122.2	62.6	128.9
4800	40.1	126.6	52.2	129.8	63.3	132.3	76.7	135.9	89.3	140.5
5000	61.4	142.8	76.2	143.3	89.5	142.3	105.5	141.0	121.0	140.5

(1) The VCO divider was bypassed (VCO\_DIV = 1) and the RFout pin was enabled. The VCOGAIN word was set to 12.

**Table 6. RFout Output Impedance vs. DIVGAIN (Divided Mode)<sup>(1)</sup>**

Freq. (MHz)	DIVGAIN=3		DIVGAIN=6		DIVGAIN=9		DIVGAIN=12		DIVGAIN=15	
	REAL	IMAGINARY	REAL	IMAGINARY	REAL	IMAGINARY	REAL	IMAGINARY	REAL	IMAGINARY
50	3.2	2.2	3.6	2.1	5.8	2.0	13.9	1.9	22.3	1.6
100	4.5	4.1	4.6	4.0	6.6	3.8	14.7	3.2	23.2	2.3
200	5.7	5.3	6.4	5.7	7.0	5.9	15.0	4.7	23.0	2.7
400	5.0	9.2	5.6	9.4	7.7	9.5	15.6	7.7	22.8	4.4
600	5.2	14.6	5.7	14.6	7.8	14.6	15.9	12.1	22.2	7.9
800	6.0	20.2	6.5	20.2	8.7	20.2	16.9	16.5	22.3	11.4
1000	7.9	25.7	8.4	25.7	10.7	25.5	18.7	20.5	22.9	14.6
1200	11.0	29.9	11.6	30.0	13.9	29.5	21.4	23.1	24.3	16.8
1400	13.2	32.3	13.9	32.3	16.1	31.7	22.5	24.3	23.9	18.2
1600	14.2	34.4	15.0	34.3	17.1	33.5	22.5	25.8	23.1	20.1
1800	13.9	37.2	14.6	37.0	16.7	36.2	21.6	28.2	21.7	22.9
2000	13.5	41.1	14.3	40.9	16.4	39.9	20.9	31.4	20.6	26.4
2200	14.8	45.1	15.6	44.7	17.8	43.6	21.7	34.5	20.9	29.7
2400	14.1	49.4	14.9	49.0	17.1	47.7	20.4	38.1	19.3	33.5
2600	12.4	52.1	13.2	51.6	15.5	50.1	18.2	40.4	16.8	36.2
2800	11.8	59.3	12.5	58.7	15.0	56.8	17.0	46.2	15.3	42.0
3000	10.7	68.3	11.5	67.6	14.0	65.2	15.2	53.4	13.0	49.2
3200	13.1	78.6	14.0	77.6	16.7	74.5	16.5	61.1	13.8	56.9
3400	18.1	89.6	18.9	88.4	21.6	84.4	19.4	69.2	16.0	65.1
3600	29.2	98.6	29.8	96.9	31.9	91.6	26.1	75.4	21.7	71.6
3800	36.0	105.8	36.5	103.9	37.8	97.5	28.9	81.1	24.0	77.8
4000	43.6	101.4	43.7	99.5	43.7	92.9	32.3	78.8	27.1	76.3
4200	40.6	122.9	40.8	120.3	40.6	111.8	26.6	94.7	20.7	91.8
4400	63.6	143.0	62.9	139.6	59.9	128.6	37.8	111.4	30.0	109.2
4600	90.9	155.3	88.8	151.4	81.1	139.6	49.9	125.8	40.3	124.9
4800	135.8	159.1	131.2	155.7	116.3	145.5	73.7	142.1	61.7	144.0
5000	179.4	135.1	173.2	133.9	153.3	131.4	107.1	147.7	94.5	155.2

(1) This was done with RFout buffer powered up and with OUTTERM=12. VCO\_DIV was set to 50.

**Table 7. RFout Output Impedance vs. OUTTERM (Divided Mode)<sup>(1)</sup>**

Freq.(MHz)	OUTTERM=3		OUTTERM=6		OUTTERM=9		OUTTERM=12		OUTTERM=15	
	REAL	IMAGINARY	REAL	IMAGINARY	REAL	IMAGINARY	REAL	IMAGINARY	REAL	IMAGINARY
50	44.1	-0.3	31.8	1.0	21.2	1.7	14.0	1.9	9.3	2.0
100	44.9	-2.2	32.8	0.7	22.1	2.5	14.8	3.2	10.0	3.5
200	43.2	-7.2	33.2	-1.2	23.3	2.8	16.1	4.7	11.3	5.6
400	33.2	-8.1	28.5	-1.5	21.9	4.5	15.7	7.7	11.2	9.1
600	28.0	-3.8	25.7	1.8	21.4	8.0	15.9	12.1	11.4	13.9
800	25.1	1.1	24.0	5.6	21.7	11.5	16.9	16.5	12.5	19.0
1000	23.7	5.8	23.3	9.6	22.4	14.7	18.7	20.5	14.6	23.8
1200	23.5	9.3	23.7	12.4	23.8	16.7	21.4	23.1	17.7	27.2
1400	22.6	12.3	22.9	14.8	23.5	18.1	22.5	24.3	19.5	28.9
1600	21.5	15.3	21.8	17.4	22.6	20.0	22.5	25.8	20.2	30.5
1800	20.2	18.8	20.5	20.7	21.3	22.8	21.6	28.2	19.7	33.0

(1) This was done in divided mode (VCO\_DIV=50) with VCOGAIN=12.

Table 7. R<sub>Fout</sub> Output Impedance vs. OUTTERM (Divided Mode)<sup>(1)</sup> (continued)

Freq.(MHz)	OUTTERM=3		OUTTERM=6		OUTTERM=9		OUTTERM=12		OUTTERM=15	
2000	19.1	22.9	19.4	24.5	20.1	26.3	20.9	31.4	19.3	36.4
2200	19.4	26.4	19.7	28.0	20.5	29.6	21.7	34.5	20.6	39.8
2400	17.9	30.4	18.2	32.0	18.9	33.4	20.4	38.1	19.8	43.6
2600	15.7	33.3	15.9	34.9	16.5	36.1	18.2	40.4	17.9	45.7
2800	14.5	39.0	14.5	40.7	15.1	42.0	17.0	46.2	17.2	51.9
3000	12.7	46.1	12.6	47.9	12.9	49.2	15.2	53.4	15.8	59.5
3200	13.5	53.5	13.3	55.5	13.8	56.9	16.5	61.1	18.0	67.8
3400	15.5	61.3	15.4	63.5	15.9	65.0	19.4	69.2	22.0	76.5
3600	20.9	67.5	21.1	70.0	21.7	71.5	26.1	75.4	30.5	82.8
3800	22.7	73.3	23.1	76.0	23.9	77.6	28.9	81.1	34.7	88.2
4000	25.4	71.7	26.2	74.5	27.1	76.1	32.3	78.8	39.0	84.7
4200	19.0	86.1	19.8	89.5	20.7	91.4	26.6	94.7	34.6	101.8
4400	26.6	102.0	28.3	106.3	29.9	108.7	37.8	111.4	49.4	118.0
4600	34.9	116.4	37.8	121.5	40.1	124.1	49.8	125.9	65.3	130.6
4800	52.1	134.8	57.4	140.3	61.1	143.1	73.7	141.9	93.8	141.8
5000	78.5	147.4	87.4	152.0	93.3	154.0	107.2	148.0	129.0	138.6

7.7.4.1 OSCin and Fin Sensitivity

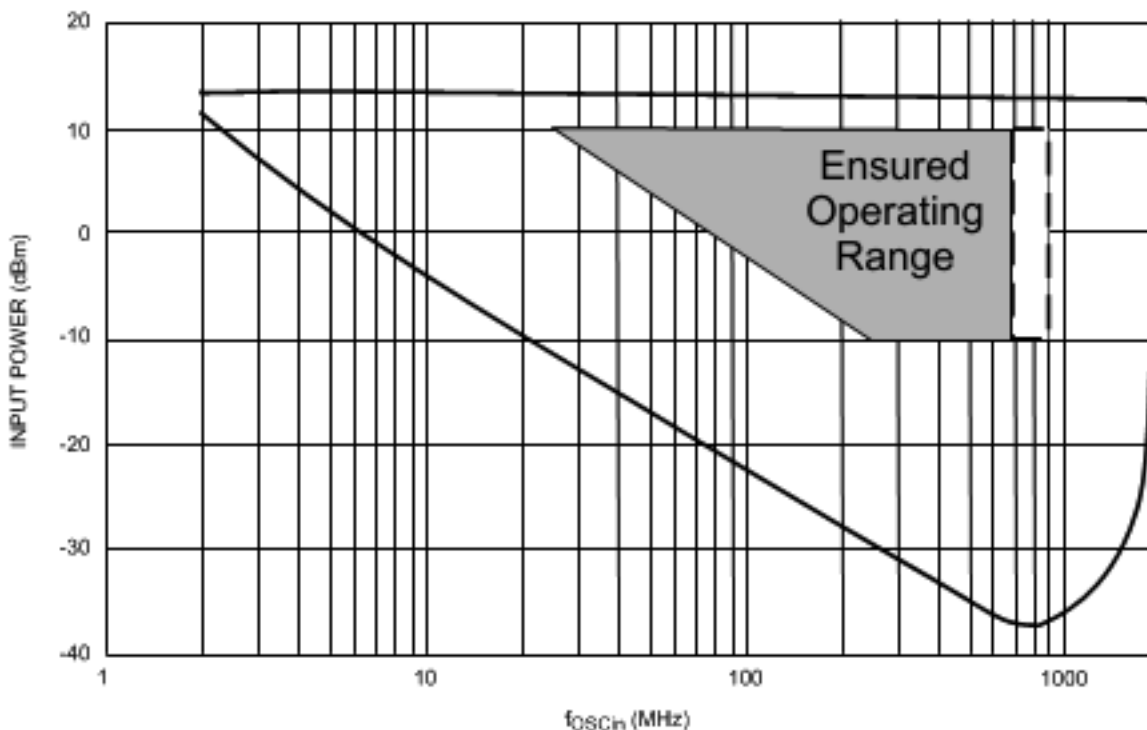

This chart shows the typical sensitivity for a sine wave. Note that at lower frequencies, there is a constant slope that suggests that the part fails when the slew rate falls below 27 V/us. The electrical specifications call for a minimum of 150 V/us to ensure margin. Also, as some of the other performance graphs show, the OSCin slew rate has an impact on fractional spurs and phase noise as well. It is recommended to design to the electrical specifications, not the typical performance plots.

Variation over voltage and temperature is typically very small and on the order than less ±1 dB.

Figure 18. OSCin Sensitivity for Single-Ended SINE Wave

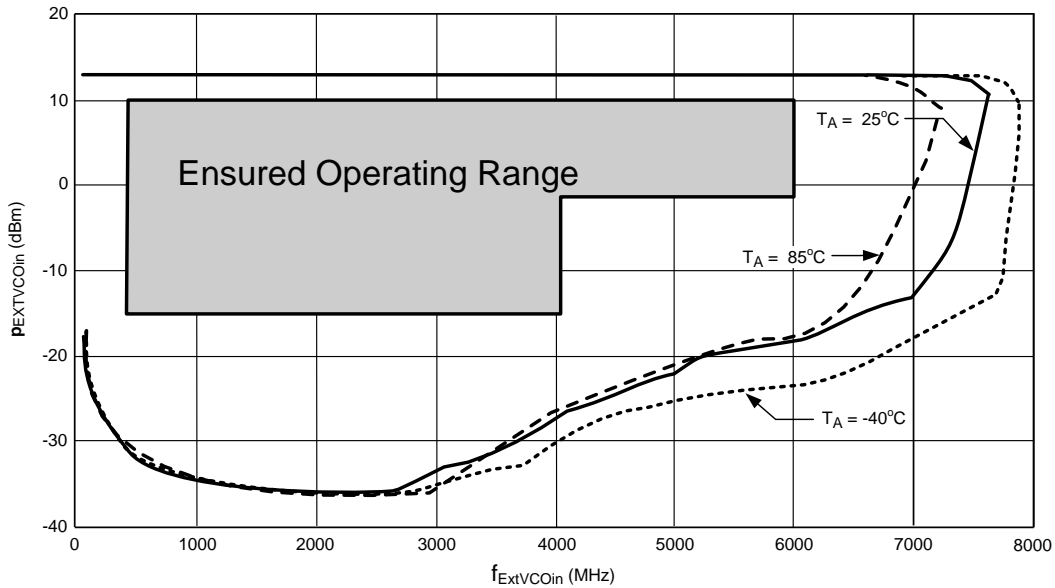

This plot shows the ExtVCOin sensitivity which applies only when the device is being used in External VCO mode.

Variation over voltage is typically very small and on the order of less than ± 1 dB.

**Figure 19. SINE wave ExtVCOin Sensitivity**

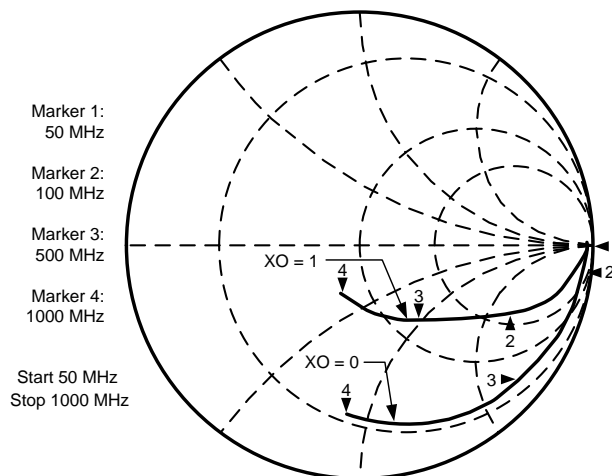

**Figure 20. OSCin Input Impedance**

**Table 8. OSCin Frequency**

FREQUENCY (MHz)	OSCin (NORMAL MODE)		OSCin (XO MODE)		OSCin# (NORMAL MODE)	
	REAL	IMAGINARY	REAL	IMAGINARY	REAL	IMAGINARY
1	3945.3	2261.6	9452.3	2182.1	3975.5	2287.0
5	4846.0	-189.6	2397.9	-916.7	4890.1	-150.1
10	4253.4	-1850.1	428.2	-1105.7	4297.4	-1886.7
20	2295.3	-2366.9	248.4	-591.8	2288.6	-2383.8
30	1290.0	-2087.0	187.1	-410.1	1304.3	-2079.1
40	847.9	-1716.1	163.5	-313.3	855.5	-1718.0

**Table 8. OSCin Frequency (continued)**

FREQUENCY (MHz)	OSCin (NORMAL MODE)		OSCin (XO MODE)		OSCin# (NORMAL MODE)	
50	581.3	-1464.9	147.9	-257.1	590.7	-1471.6
60	439.2	-1254.1	138.3	-219.0	449.4	-1264.2
70	337.9	-1105.7	131.1	-192.0	349.0	-1115.4
80	269.4	-983.6	127.0	-171.8	276.3	-989.1
90	223.4	-869.9	119.7	-158.0	231.9	-876.2
100	179.2	-776.8	114.5	-143.9	186.9	-783.9
200	52.4	-379.8	93.9	-85.1	54.3	-382.5
300	31.2	-247.0	80.9	-68.9	31.9	-247.4
400	23.5	-181.7	72.3	-58.1	23.8	-180.5
500	20.4	-140.5	65.1	-49.4	20.4	-138.4
600	18.4	-110.2	58.1	-42.1	18.2	-107.6
700	17.0	-88.0	51.9	-35.6	16.7	-85.3
800	15.8	-71.2	47.4	-29.5	15.7	-68.4
900	15.2	-57.6	43.6	-23.4	14.7	-56.3
1000	15.1	-45.2	40.9	-17.2	14.3	-44.7

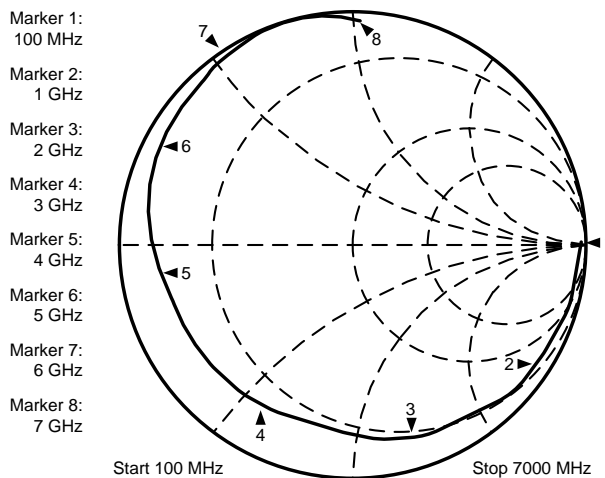

**Figure 21. ExtVCOin Input Impedance**

**Table 9. ExtVCOin Frequency**

FREQUENCY	REAL	IMAGINARY
100	627.9	-1532.3
200	193.8	-852.6
400	56.4	-434.5
600	31.3	-287.4
800	23.2	-212.9
1000	17.8	-167.0
1200	15.4	-134.9
1400	14.0	-111.4
1600	12.8	-93.7
1800	11.8	-79.5
2000	11.2	-67.5
2200	10.7	-57.4
2400	10.2	-48.6
2600	10.5	-42.0
2800	9.1	-35.5
3000	7.8	-29.0
3200	7.2	-23.4
3400	6.6	-18.3
3600	5.9	-13.3
3800	5.3	-8.5
4000	5.0	-3.7
4200	4.5	-1.4
4400	4.0	0.9
4600	3.5	3.1
4800	2.6	7.7
5000	1.7	12.1
6000	0.9	26.7
7000	2.3	51.9

## 8 Parameter Measurement Information

### 8.1 Bench Test Setups

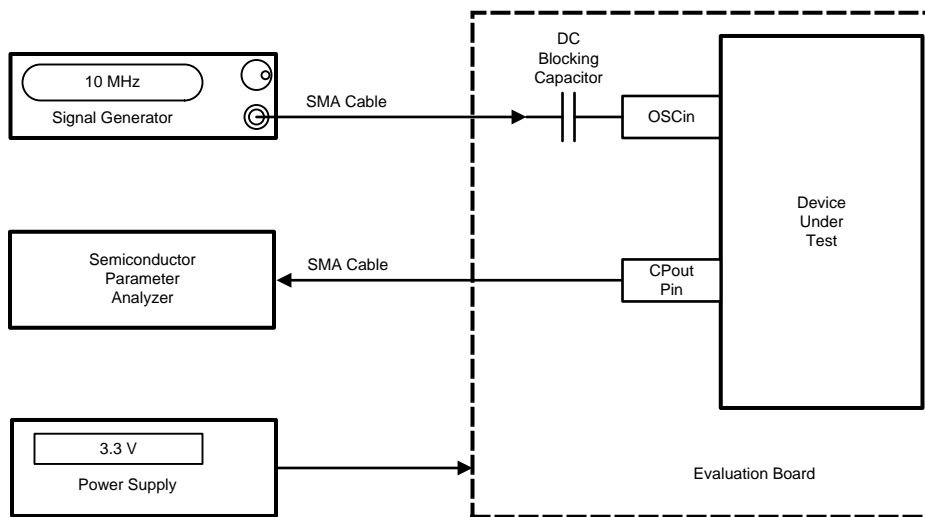

Figure 22. Charge Pump Currents Test Setup

The charge pump is tested in external VCO mode (MODE=1), although it is no external VCO hooked up. The CPout pin should be disconnected from the any external VCO tuning pin, external loop filter, and also the Vtune pin on the device. A signal is then applied to the OSCin pin to ensure that the R counter is oscillating. This signal does not have to be clean and the frequency is very critical. These currents at the CPout pin are typically measured with a semiconductor parameter analyzer.

#### 8.1.1 Charge Pump Current Measurements

In order to test the TRI-STATE current, the CPT bit is set to one and the current is measured. Aside from having no other sources of leakage attached to this pin, it is also important that the board be well cleaned before doing this test. The temperature and voltage at the charge pump can then be varied and the resulting leakage current is then recorded. Typically, the leakage currents are worst at higher temperatures and higher charge pump voltages.

In order to test the source and sink currents, the CPT bit is set to active mode and the frequency is programmed to something much higher than can be achieved in order to force the charge pump to rail. The reason why this is necessary is that the duty cycle of the charge pump is not 100% unless it is forced against one of the rails. If the charge pump polarity bit (CPP) is set to positive, then the charge pump source current is measured. To measure the sink current, the CPT bit is set to negative. The part is then programmed and the charge pump will rail in one direction. The semiconductor parameter analyzer measures the current at a particular charge pump voltage. The phase detector polarity bit, CPP, can be toggled to test between the negative and positive charge pump gains. In order to test leakage, set the TRI-STATE bit, CPT, to 1 so that this can be measured. For the most accurate measurements, it is desirable that the CPout and Vtune pin are not shorted together for these measurements. Once these currents are measured, then the datasheet parameters can be calculated.

A summary of these charge pump tests is given in the table below.

MEASUREMENT	PLL_R	PLL_N	CPG	CPT	CPP
Leakage Current	X	X	X	1 (TRI-STATE)	X
Source Current	1	4000	0 - 31	0 (Active)	1 (Positive)
Sink Current	1	4000	0 - 31	0 (Active)	0 (Negative)

## 8.1.2 Charge Pump Current Definitions

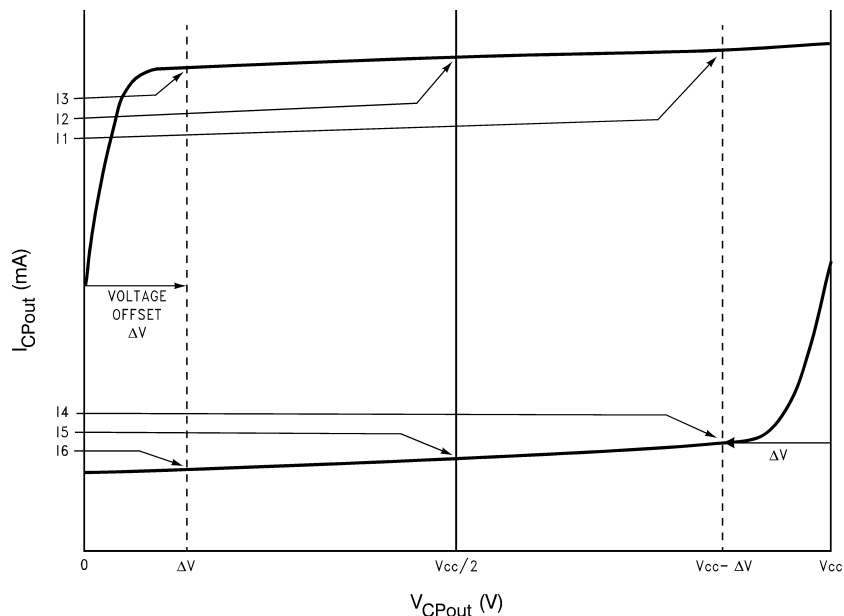
**Figure 23. Charge Pump Current Definitions**

I1 = Charge Pump Sink Current at  $V_{CPout} = V_{CC} - \Delta V$

I2 = Charge Pump Sink Current at  $V_{CPout} = V_{CC}/2$

I3 = Charge Pump Sink Current at  $V_{CPout} = \Delta V$

I4 = Charge Pump Source Current at  $V_{CPout} = V_{CC} - \Delta V$

I5 = Charge Pump Source Current at  $V_{CPout} = V_{CC}/2$

I6 = Charge Pump Source Current at  $V_{CPout} = \Delta V$

$\Delta V$  = Voltage offset from the positive and negative supply rails. Defined to be 0.4 volts for this part.

**Figure 24. Variation of Charge Pump Current Magnitude vs. Charge Pump Voltage**

$$I_{CPout} \text{ vs } V_{CPout} = \frac{(|I1| - |I3|)}{(|I1| + |I3|)} \times 100\%$$

$$= \frac{(|I4| - |I6|)}{(|I4| + |I6|)} \times 100\%$$

**Figure 25. Variation of Charge Pump Current Magnitude vs. Temperature**

$$I_{CPout} \text{ vs } T_A = \frac{|I2|_{T_A} - |I2|_{T_A=25^\circ C}}{|I2|_{T_A=25^\circ C}} \times 100\%$$

$$= \frac{|I5|_{T_A} - |I5|_{T_A=25^\circ C}}{|I5|_{T_A=25^\circ C}} \times 100\%$$

$$I_{CPout \text{ Sink}} \text{ vs } I_{CPout \text{ Source}} = \frac{|I2| - |I5|}{\frac{1}{2}(|I2| + |I5|)} \times 100\%$$

**Figure 26. Charge Pump Sink vs. Source Current Mismatch**



### 9.3 Feature Description

The LMX2541 is a low power, high performance frequency synthesizer system which includes a PLL, Partially Integrated Loop Filter, VCO, VCO Divider, and Programmable Output Buffer. There are three basic modes that the device can be configured in: Full Chip Mode, External VCO Mode, and Divider Only Mode. Full chip mode is intended to be used with the internal VCO and PLL. There is also the option of External VCO mode, which allows the user to connect their own external VCO. Finally, there is Divider only, which is just the VCO divider and output buffer. The active blocks for these modes are described in [Table 10](#):

**Table 10. Active Blocks**

MODE	AVAILABLE BLOCKS				
	PLL	LOOP FILTER	VCO	VCO DIVIDER	OUTPUT BUFFER
Full Chip	Yes	Yes	Yes	Yes	Yes
External VCO	Yes	No	No	Yes	Yes
Divider Only	No	No	No	Yes	Yes

#### 9.3.1 PLL Reference Oscillator Input Pins

There are three basic ways that the OSCin/OSCin\* pins may be configured as shown in the table below:

MODE	DESCRIPTION	XO BIT
Crystal	Device is used with a crystal oscillator	1
Single Ended	Device is driven with a single-ended source, such as a TCXO.	0
Differential	Use this mode when driving with a differential signal, such as an LVDS signal.	0

In addition to the way that the OSCin/OSCin\* pins are driven, there are also bits that effect the frequency that the chip uses. The OSC\_FREQ word needs to be programmed correctly, or the VCO may have issues locking to the proper frequency, because the VCO frequency calibration is based on this word.

**Table 11. Word Name and Function**

WORD NAME	FUNCTION
OSC_FREQ	This needs to be set correctly if the internal VCO is used for proper calibration.
OSC2X	This allows the oscillator frequency to be doubled. The R divider is bypassed in this case.

Higher slew rates tend to yield the best fractional spurs and phase noise, so a square wave signal is best for OSCin. Single ended mode and differential mode have similar results if a square wave is used to drive the OSCin pin. If using a sine wave, higher frequencies tend to work better due to their higher slew rates.

#### 9.3.2 PLL R Divider

The R divider divides the OSCin frequency down to the phase detector frequency. If the doubler is enabled, then the R divider is bypassed.

#### 9.3.3 PLL Phase Detector and Charge Pump

The phase detector compares the outputs of the R and N dividers and generates a correction current corresponding to the phase error. This charge pump current is software programmable to 32 different levels. The phase detector frequency,  $f_{PD}$ , can be calculated as follows:

$$f_{PD} = f_{OSCin} / R \quad (1)$$

### 9.3.4 PLL N Divider and Fractional Circuitry

The N divider in the LMX2541 includes fractional compensation and can achieve any fractional denominator (PLL\_DEN) from 1 to 4,194,303. The integer portion, PLL\_N, is the whole part of the N divider value and the fractional portion, PLL\_NUM / PLL\_DEN, is the remaining fraction. PLL\_N, PLL\_NUM, and PLL\_DEN are software programmable. So in general, the total N divider value, N, is determined by:

$$N = \text{PLL\_N} + \text{PLL\_NUM} / \text{PLL\_DEN} \quad (2)$$

The order of the delta-sigma modulator is programmable from integer mode to fourth order. There are also several dithering modes that are also programmable. In order to make the fractional spurs consistent, the modulator is reset any time that the R0 register is programmed.

### 9.3.5 Partially Integrated Loop Filter

The LMX2541 integrates the third pole (formed by R3\_LF and C3\_LF) and fourth pole (formed by R4\_LF and C4\_LF) of the loop filter. The values for these integrated components can be programmed independently through the MICROWIRE interface. The larger the values of these components, the stronger the attenuation of the internal loop filter. The maximum attenuation can be achieved by setting the internal resistors and capacitors to their maximum value and the minimum attenuation can be attained by setting all of these to their minimum setting. This partially integrated loop filter can only be used in full chip mode.

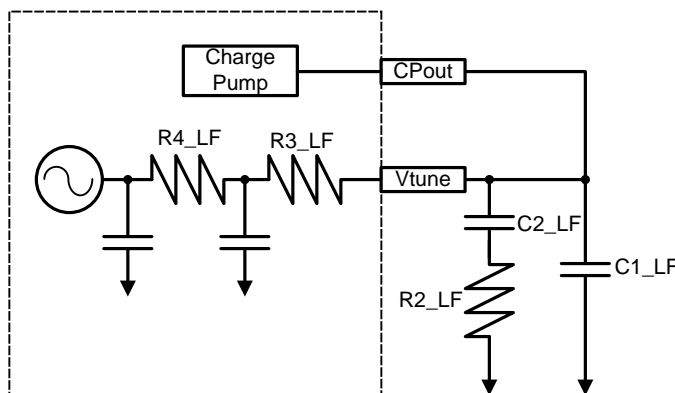

Figure 29. Partially Integrated Loop Filter

### 9.3.6 Low Noise, Fully Integrated VCO

The LMX2541 includes a fully integrated VCO, including the inductors. The VCO (Voltage Controlled Oscillator) takes the voltage from the loop filter and converts this into a frequency. The VCO frequency is related to the other frequencies and divider values as follows:

$$f_{\text{VCO}} = f_{\text{PD}} \times N = f_{\text{OSCin}} \times N / R \quad (3)$$

In order to reduce the VCO tuning gain and therefore improve the VCO phase noise performance, the VCO frequency range is divided into many different frequency bands. This creates the need for frequency calibration in order to determine the correct frequency band given a desired output frequency. The frequency calibration routine is activated any time that the R0 register is programmed. It is important that the OSC\_FREQ word is set correctly to have this work correctly.

The VCO also has an internal amplitude calibration algorithm to optimize the phase noise which is also activated any time the R0 register is programmed. The optimum internal settings for this are temperature dependent. If the temperature is allowed to drift too much without being re-calibrated, some minor phase noise degradation could result. For applications where this is an issue, the AC\_TEMP\_COMP word can be used to sacrifice phase noise at room temperature in order to improve the VCO phase noise over all temperatures. The maximum allowable drift for continuous lock,  $\Delta T_{\text{CL}}$ , is stated in the electrical specifications. For this part, a number of +125 C means the part will never lose lock if the part is operated under recommended operating conditions.

### 9.3.7 Programmable VCO Divider

The VCO divider can be programmed to any value from 2 to 63 as well as bypass mode if device is in full chip mode. In external VCO mode or divider mode, all values except bypass mode can be used for the VCO divider. The VCO divider is not in the feedback path between the VCO and the PLL and therefore has no impact on the PLL loop dynamics. After this programmable divider is changed, it may be beneficial to reprogram the R0 register to recalibrate the VCO. The frequency at the RFout pin is related to the VCO frequency and divider value, VCO\_DIV, as follows:

$$f_{\text{RFout}} = f_{\text{VCO}} / \text{VCO\_DIV} \quad (4)$$

When this divider is enabled, there will be some far-out phase noise contribution to the VCO noise. Also, it may be beneficial for VCO phase noise to reprogram the R0 register to recalibrate the VCO if the VCO\_DIV value is changed from bypass to divided, or vice-versa.

The duty cycle for this divider is always 50%, even for odd divide values. Because of the architecture of this divider that allows it to work to high frequencies and always have a 50% duty cycle, there are a few extra considerations:

- In divider only mode, there must be five clock cycles on the ExtVCOin pin after the divide value is programmed in order to cause the divide value to properly changed. It is fine to use more than 5 clock cycles for this purpose.
- For a divide of 4 or 5 ONLY, the R4 register needs to be programmed one more time after the device is fully programmed in order synchronize the divider. Failure to do so will cause the VCO divider to divide by the wrong value. Furthermore, if the VCO signal ever goes away, as is the case when the part is powered down, it is necessary to reprogram the R4 register again to re-synchronize the divider. Furthermore, if the R0 register is ever programmed in full chip mode, it is also necessary to reprogram the R4 register.

### 9.3.8 Programmable RF Output Buffer

The output power at the RFout pin can be programmed to various levels as well as on and off states. The output state of this pin is controlled by the RFoutEN pin as well as the RFOUT word. The RF output buffer can be disabled while still keeping the PLL in lock. In addition to this, the actual output power level of this pin can be adjusted using the VCOGAIN, DIVGAIN, and OUTTERM programming words. The reader should note that VCOGAIN controls the gain of the VCO buffer, not the tuning constant in of the VCO.

### 9.3.9 Powerdown Modes

The LMX2541 can be powered up and down using the CE pin or the POWERDOWN bit. When the device is powered down, the programming and VCO calibration information is retained, so it is not necessary to re-program the device when the device comes out of the powered down state (The one exception is when the VCO\_DIV value is 4 or 5, which has already been discussed.). The following table shows how to use the bit and pin.

CE PIN	POWERDOWN BIT	DEVICE STATE
Low	Don't Care	Powered Down
High	0	Powered Up
	1	Powered Down

The device can be programmed in the powerdown state. However, the VCO frequency needs to be changed when the device is powered up because the VCO calibration does not run in the powerdown state. Also, the special programming for VCO\_DIV = 4 or 5 has to be done when the part is powered up. In order for the CE pin to properly power the device down when it is held low, the all registers in the device need to have been programmed at least one time.

### 9.3.10 Fastlock

The LMX2541 includes the Fastlock feature that can be used to improve the lock times. When the frequency is changed, a timeout counter is used to engage the fastlock for a programmable amount of time. During the time that the device is in Fastlock, the FLout pin changes from high impedance to low, thus switching in the external resistor R2pLF with R2\_LF as well as changing the internal loop filter values for R3\_LF and R4\_LF.

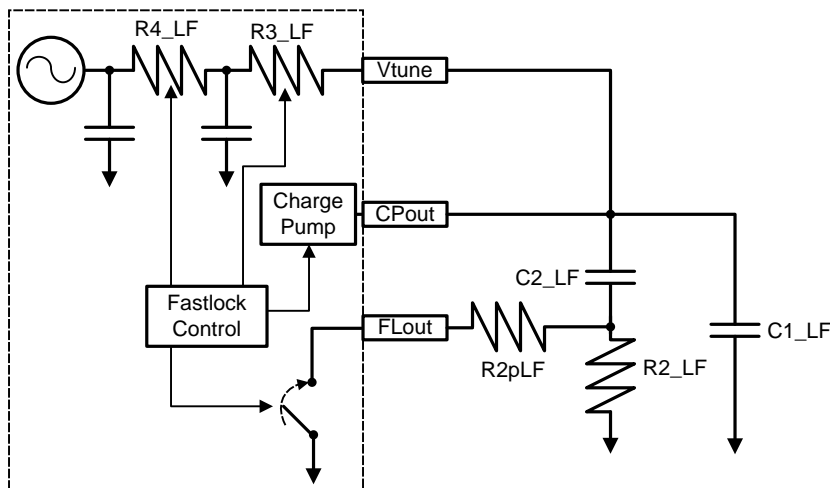

Figure 30. Fastlock Schematic

Table 12 shows the charge pump gain, loop filter resistors, and FLout pin change between normal operation and Fastlock.

Table 12. Normal Operation vs Fastlock

PARAMETER	NORMAL OPERATION	FASTLOCK
Charge Pump Gain	CPG	FL_CPG
Loop Filter Resistor R3_LF	R3_LF	FL_R3_LF
Loop Filter Resistor R4_LF	R4_LF	FL_R4_LF
FLout Pin	High Impedance	Low

Once the loop filter values and charge pump gain are known for normal mode operation, they can be determined for fastlock operation as well. In normal operation, one cannot use the highest charge pump gain and still use fastlock because there will be no larger current to switch in. If the resistors and the charge pump current are done simultaneously, then the phase margin can be preserved while increasing the loop bandwidth by a factor of K as shown in the following table:

PARAMETER	SYMBOL	CALCULATION
Charge pump gain in Fastlock	FL_CPG	Typically choose to be the largest value.
Loop Bandwidth Multiplier	K	$K = \sqrt{\text{FL\_CPG/CPG}}$
Internal Loop Filter Resistor	FL_R3_LF	$\text{FL\_R3\_LF} = \text{R3\_LF} / K$
Internal Loop Filter Resistor	FL_R4_LF	$\text{FL\_R4\_LF} = \text{R4\_LF} / K$
External Loop Filter Resistor	R2pLF	$\text{R2pLF} = \text{R2\_LF} / (K - 1)$

### 9.3.11 Lock Detect

The Ftest/LD pin of the LMX2541 can be configured to output a signal that gives an indication for the PLL being locked. There are two styles of lock detect; analog and digital. The analog lock detect signal is more of a legacy feature and consists a series of narrow pulses that correspond to when the charge pump comes on. These pulses can be integrated with an external RC filter to create generate a lock detect signal. Analog lock detect can be configured in a push-pull output or an open drain output. The analog open drain lock detect signal can be integrated with a similar RC filter and requires an additional pullup resistor. This pullup resistor can be much larger than the resistor in the RC filter in order to make unbalanced time constants for improved sensitivity.

The digital lock detect function can also be selected for the Ftest/LD pin to give a logic level indication of lock or unlock. The digital lock detect circuitry works by comparing the difference between the phase of the inputs to the phase detector with a RC generated delay of  $\epsilon$ . To indicate a locked state (Lock = HIGH) the phase error must be less than  $\epsilon$  for 5 consecutive phase detector cycles. Once in lock (Lock = HIGH), the RC delay is changed to  $\delta$ . To indicate an out of lock state (Lock = LOW), the phase error must become greater than  $\delta$ . The values of  $\epsilon$  and  $\delta$  are programmable with the DLOCK word.

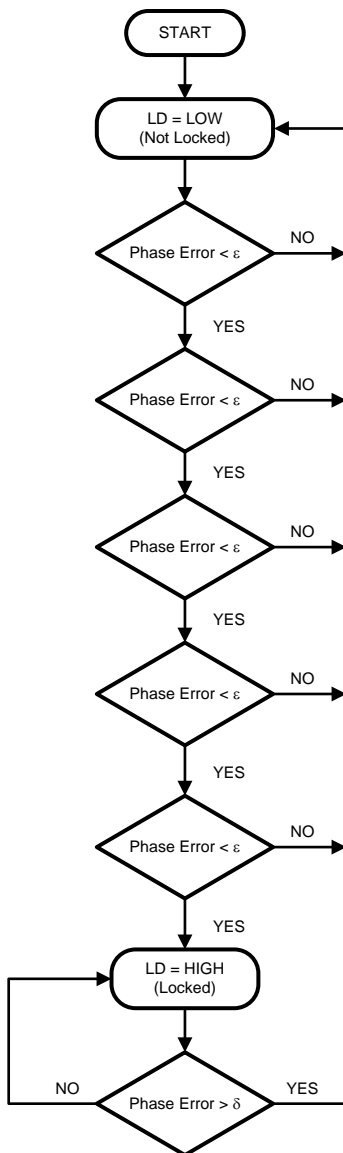

Figure 31. Lock Detect

9.3.12 Current Consumption

The current consumption of the LMX2541 has many factors that influence it. Determining the current consumption for the entire device involves knowing which blocks are powered up and adding their currents together. The current in the electrical specifications gives some typical cases, but there could be some variation over factors such as the phase detector frequency. Also, the output buffer current can be impacted by the software controllable settings. By subtracting or adding combinations of the currents for the RFout buffer and VCO divider, the current consumption for the device can be estimated for any usable configuration. The currents for the buffer and VCO divider are as follows:

BLOCK	CURRENT (mA)
RF Output Buffer	~ 40 (See <i>Programmable Output Power with On/Off</i> )
VCO Divider	32

### 9.3.13 Fractional Spurs

#### 9.3.13.1 Primary Fractional Spurs

The primary fractional spurs occur at multiples of the channel spacing and can change based on the fraction. For instance, if the phase detector frequency is 10 MHz, and the channel spacing is 100 kHz, then this could be achieved using a fraction of 1/100. The fractional spurs would be at offsets that are multiples 100 kHz.

#### 9.3.13.2 Sub-Fractional Spurs

Sub-fractional spurs occur at sub-multiples of the channel spacing, Fch. For instance, in the above example, there could be a sub-fractional spur at 50 kHz. The occurrence of these spurs is dependent on the modulator order. Integer mode and the first order modulator never have sub-fractional spurs. If the fractional denominator can be chosen to avoid factors of 2 or 3, then there will also be no sub-fractional spurs. Sub-fractional spurs get worse for higher order modulators. Dithering tends to reduce sub-fractional spurs at the expense of increasing PLL phase noise. [Table 13](#) provides guidance on predicting sub-fractional spur offset frequencies.

**Table 13. Sub-Fractional Spur Offset Frequencies  
vs.  
Modulator Order and Fractional Denominator Factors**

ORDER	FRACTIONAL DENOMINATOR FACTORS			
	NO FACTOR of 2 or 3	FACTOR of 2 but not 3	FACTOR of 3 but not 2	FACTOR of 2 and 3
Integer Mode	None	None	None	None
1st Order Modulator	None	None	None	None
2nd Order Modulator	None	Fch/2	None	Fch/2
3rd Order Modulator	None	Fch/2	Fch/3	Fch/6
4th Order Modulator	None	Fch/4	Fch/3	Fch/12

### 9.3.14 Impact of VCO\_DIV on Fractional Spurs

Because the fractional and sub-fractional spur levels do not depend on output frequency, there is a big benefit to division. In general, every factor of 2 gives a 6 dB improvement to fractional spurs. Also, because the spur offset frequency is not divided, the channel spacing at the VCO can be also increased to improve the spurs. However, if the on-chip VCO is used, crosstalk can cause spurs at a frequency of  $f_{RFout} \bmod f_{PD}$ . Consider the following example of a 50 MHz phase detector frequency and VCO\_DIV = 2. If the VCO is at 3000.1 MHz and divided by 2 to get 1500.05 MHz, there will be a spur at an offset of 50 kHz (1500.05 MHz mod 50 MHz). However, if the VCO frequency is at 3050.1 MHz, the output will be at 1525.05 MHz, but the spur will be at a much farther offset that can easily be filtered by the loop filter of 25.05 MHz (1525.05 MHz mod 50 MHz).

### 9.3.15 PLL Phase Noise

#### 9.3.15.1 [Figure 6](#), LMX2541SQ3740E Raw Phase Noise Measurement Plot Description

The above plot demonstrates the PLL phase noise of the LMX2541SQ3700E operating at 3700 MHz output frequency, phase detector frequency of 100 MHz, and charge pump gain of 32X. The loop bandwidth was made as wide as possible to fully expose the PLL phase noise and reference source was a 100 MHz Wenzel crystal. This measurement was done in integer mode. To better understand the impact of using fractional mode, consult the applications section.

The measured noise is the sum of the PLL 1/f noise and noise floor. At offsets below 1 kHz, the PLL 1/f noise dominates and changes at a rate of 10 dB/decade. The noise at 1 kHz is dominated by this 1/f noise and has a value of -103 dBc/Hz. In the 100 - 200 kHz offset range, the noise is -113.7 dBc/Hz and is dominated by the PLL noise floor. It can be shown that if the effects of the loop filter peaking and the 1/f noise are subtracted away from this measurement, it would be about 0.6 dB better.

If the phase detector frequency is changed with the VCO frequency held constant, the PLL noise floor will change, but the 1/f noise will remain the same. If the VCO frequency is changed, both the 1/f noise and PLL noise floor change at a rate of 20 dB/decade.

### 9.3.15.2 Figure 37, LMX2541SQ2690 System Phase Noise Plot Description

For this plot, a third order modulator with dithering disabled was used with a fractional denominator of 500000. The charge pump gain was 32X and the loop filter components were C1 = 2.2 nF, C2 = 22 nF, R2 = 470 Ω. The internal loop filter components were C3\_LF = 20 pF, C4\_LF = 100 pF, R3\_LF = 1 kΩ, R4\_LF = 200 Ω. The VCO frequency is 2720.1 MHz. The OSCin signal was a 500 MHz differential LVPECL output of the LMK04033.

### 9.3.15.3 Phase Noise of PLL

Disregarding the impact of reference oscillator noise, loop filter resistor thermal noise, and loop filter shaping, the phase noise of the PLL can be decomposed into three components: flicker noise, flat noise, and fractional noise. These noise sources add in an RMS sense to produce the total PLL noise. In other words:

$$L_{PLL}(f) = 10 \cdot \log(10^{L_{PLL\_flat}(f/10)} + 10^{L_{PLL\_flicker}(f/10)} + 10^{L_{PLL\_fractional}(f/10)}) \quad (5)$$

**Table 14. Potential Influencing Factors**

SYMBOL	POTENTIAL INFLUENCING FACTORS				
	f	f <sub>VCO</sub>	f <sub>PD</sub>	K <sub>PD</sub>	FRAC
L <sub>PLL_flat</sub> (f)	No	Yes	Yes	Yes	No
L <sub>PLL_flicker</sub> (f)	Yes	Yes	No	Yes	No
L <sub>PLL_fractional</sub> (f)	Yes	No	Yes	No	Yes

The preceding table shows which factors of offset frequency (f), VCO frequency (f<sub>VCO</sub>), phase detector frequency (f<sub>PD</sub>), charge pump gain (K<sub>PD</sub>), and the fractional settings (FRAC) can potentially influence each phase noise component. The fractional settings include the fraction, modulator order, and dithering.

For the flat noise and flicker noise, it is possible to normalize each of these noise sources into a single index. By normalizing these noise sources to an index, it makes it possible to calculate the flicker and flat noise for an arbitrary condition. These indices are reported in the electrical characteristics section and in the typical performance curves.

**Table 15. Noise Component**

NOISE COMPONENT	INDEX	RELATIONSHIP
L <sub>PLL_flat</sub> (f)	LN <sub>PLL_flat</sub> (1 Hz)	L <sub>PLL_flat</sub> (f) = LN <sub>PLL_flat</sub> (1 Hz) + 20·log(N) + 10·log(f <sub>PD</sub> )
L <sub>PLL_flicker</sub> (f)	LN <sub>PLL_flicker</sub> (10 kHz)	L <sub>PLL_flicker</sub> (f) = LN <sub>PLL_flicker</sub> (10 kHz) - 10·log(10 kHz / f) + 20·log(f <sub>VCO</sub> / 1 GHz)

The flat noise is dependent on the PLL N divider value (N) and the phase detector frequency (f<sub>PD</sub>) and the 1 Hz Normalized phase noise (LN<sub>PLL\_flat</sub>(1 Hz)). The 1 Hz normalized phase noise can also depend on the charge pump gain as well. In order to make an accurate measurement of just the flat noise component, the offset frequency must be chosen sufficiently smaller than the loop bandwidth of the PLL, and yet large enough to avoid a substantial noise contribution from the reference and PLL flicker noise. This becomes easier to measure for lower phase detector frequencies.

The flicker noise, also known as 1/f noise, can be normalized to 1 GHz carrier frequency and 10 kHz offset, LN<sub>PLL\_flicker</sub>(10 kHz). Flicker noise can dominate at low offsets from the carrier and has a 10 dB/decade slope and improves with higher charge pump currents and at higher offset frequencies. To accurately measure the flicker noise it is important to use a high phase detector frequency and a clean crystal to make it such that this measurement is on the 10 dB/decade slope close to the carrier. L<sub>PLL\_flicker</sub>(f) can be masked by the reference oscillator performance if a low power or noisy source is used.

An alternative way to interpret the flicker noise is the 1/f noise corner, f<sub>corner</sub>. This would be the offset frequency where the flat noise and flicker noise are equal. This corner frequency changes as a function of the phase detector frequency and can be related to the flat and flicker noise indices as shown below.

$$f_{corner} = 10^{(LN_{PLL\_flicker}(10\text{ kHz}) - LN_{PLL\_flat}(1\text{ Hz}) - 140) / 10} \times f_{PD} \quad (6)$$

Based on the values for LNPLL\_flicker(10 kHz) and LNPLL\_flat(1Hz) as reported in the electrical specifications, the corner frequency can be calculated. For example, one of the plots in the typical performance characteristics shows the phase noise with a 100 MHz phase detector frequency and 32X charge pump gain. In this case, this corner frequency works out to be  $0.000123 \times 100 \text{ MHz} = 12.3 \text{ kHz}$ .

K <sub>PD</sub>	LNPLL_flicker(10 kHz)	LNPLL_flat(1 Hz)	f <sub>corner</sub>
1X	-116.0 dBc/Hz	-220.8 dBc/Hz	$0.000302 \times f_{PD}$
32X	-124.5 dBc/Hz	-225.4 dBc/Hz	$0.000123 \times f_{PD}$

For integer mode or a first order modulator, there is no fractional noise (disregarding fractional spurs). For higher order modulators, the fractional engine may or may not add significant phase noise depending on the fraction and choice of dithering.

### 9.3.16 Impact of Modulator Order, Dithering, and Larger Equivalent Fractions on Spurs and Phase Noise

To achieve a fractional N value, an integer N divider is modulated between different values. This gives rise to three main degrees of freedom with the LMX2541 delta-sigma engine: the modulator order, dithering, and the way that the fractional portion is expressed. The first degree of freedom, the modulator order, can be selected as zero (integer mode), one, two, three, or four. One simple technique to better understand the impact of the delta-sigma fractional engine on noise and spurs is to tune the VCO to an integer channel and observe the impact of changing the modulator order from integer mode to a higher order. A higher fractional modulator order in theory yields lower primary fractional spurs. However, this can also give rise to sub-fractional spurs in some applications. The second degree of freedom is dithering. Dithering seeks to improve the sub-fractional spurs by randomizing the sequence of N divider values. In theory, a perfectly randomized sequence would eliminate all sub-fractional spurs, but add phase noise by spreading the energy that would otherwise be contained in the spurs. The third degree of freedom is the way that the fraction is expressed. For example, 1/10 can be expressed as a larger equivalent fraction of 100000/1000000. Using larger equivalent fractions tends to increase randomization similar to dithering. In general, the very low phase noise of the LMX2541 exposes the modulator noise when dithering and large fractions are used, so use these with caution. The avid reader is highly encouraged to read application note 1879 for more details on fractional spurs. The following table summarizes the relationships between spur types, phase noise, modulator order, dithering and fractional expression.

NOISE / SPUR TYPE	ACTION		
	INCREASE MODULATOR ORDER	INCREASE DITHERING	USING LARGER EQUIVALENT FRACTIONS
Phase Noise	WORSE (But only for larger fractions or more dithering)	WORSE	WORSE
Primary Fractional Spur	BETTER	NO IMPACT	NO IMPACT
Sub-Fractional Spurs	WORSE (Creates more sub-fractional spurs)	BETTER	BETTER

### 9.3.17 Modulator Order

In general, the fractional mode of the PLL enables the use of a higher phase detector frequency relative to the channel spacing, which enables the in-band noise of the PLL to be lower. The choice of modulator order to be used in fractional mode is based on how much higher  $f_{PD}$  can be made relative to the channel spacing and the acceptable spur levels. The LMX2541 has a programmable modulator order which allows the user to make a trade-off between PLL noise and primary and sub-fractional spur performance. The following table provides some general guidelines for choosing modulator order: Note that the spurs due to crosstalk will not be impacted by modulator order.

ORDER	GUIDELINES FOR USE
Integer Mode	<ul style="list-style-type: none"> <li>Use if <math>f_{PD}</math> can be made very high without using a fractional N value.</li> <li>Use if it is not desired to make <math>f_{PD}</math> higher using a fractional N value. This could be the case if the loop bandwidth is very narrow and smaller loop filter capacitors are desired.</li> </ul>
1st Order Modulator	<ul style="list-style-type: none"> <li>Use 1st order if <math>f_{PD}</math> can be increased by at least a factor of four over the integer case and fractional spur frequencies and levels are acceptable.</li> <li>If the channel spacing is 5 MHz or greater, the 1st order modulator may provide better spur performance than integer mode.</li> </ul>
2nd Order Modulator 3rd Order Modulator 4th Order Modulator	<ul style="list-style-type: none"> <li>If the spurs of the 1st order modulator are unacceptable, use a higher order modulator. If the spurious components are due to crosstalk they will not be improved by increasing modulator order. In this case, use the lowest order modulator that gives acceptable performance.</li> <li>Use if the spurs of the 1st order modulator are unacceptable.</li> <li>In general, use the lowest order modulator unless a higher order modulator yields an improvement in primary fractional spurs. If the spurious components are due to crosstalk, they will not be improved by increasing the modulator order.</li> </ul>

### 9.3.18 Programmable Output Power with On/Off

The power level of the RFout pin is programmable, including on/off controls. The RFoutEN pin and RFOUT word can be used to turn the RFout pin on and off while still keeping the VCO running and in lock. In addition to on/off states, the power level can also be programmed in various steps using the VCOGAIN, DIVGAIN, and OUTTERM programming words. There are tables in the [Typical Characteristics](#) section that discuss the impact of these words on the output power. In addition to impacting the output power, these words also impact the current consumption of the device. This data was obtained as an average over all frequencies. In general, it is desirable to find the combination of programming words that gives the lowest current consumption for a given output power level. All numbers reported are relative to the case of VCOGAIN = OUTTERM = 12. According to this data, using a VCOGAIN or OUTTERM value of 12 or greater yields only a small increase in output power, but a large increase in current consumption.

**Table 16. Change in Current Consumption in Bypass Mode as a Function of VCOGAIN and OUTTERM**

		VCOGAIN				
		3	6	9	12	15
OUTTERM	3	-26.0	-22.3	-18.6	-15.1	-11.8
	6	-18.5	-15.5	-12.6	-9.7	-6.9
	9	-11.1	-9.0	-6.9	-4.7	-2.5
	12	-3.8	-2.6	-1.4	+0.0	+1.5
	15	+3.3	+3.7	+4.0	+4.5	+5.3

**Table 17. Change in Current Consumption in Divided Mode as a Function of DIVGAIN and OUTTERM**

		DIVGAIN				
		3	6	9	12	15
OUTTERM	3	-24.4	-21.7	-18.7	-15.9	-13.3
	6	-16.2	-14.6	-12.6	-10.1	-8.0
	9	-8.3	-7.6	-6.8	-5.0	-3.2
	12	-0.5	-0.7	-0.7	+0.0	+1.3
	15	+7.1	+6.0	+5.2	+4.9	+5.6

### 9.3.19 Loop Filter

Loop filter design can be rather complicated, but there are design tools and references available at [www.ti.com](http://www.ti.com). The loop bandwidth can impact the size of loop filter capacitors and also how the phase noise is filtered. For optimal integrated phase noise, choose the bandwidth to be about 20% wider than the frequency where the in-band PLL phase noise (as described in [PLL Phase Noise](#)) and open loop VCO noise cross. This optimal loop bandwidth may need adjustment depending on the application requirements. Reduction of spurs can be achieved

by reducing the loop bandwidth. On the other hand, a wider loop bandwidth may be required for faster lock time. Note that using the integrated loop filter components can lead to a significant restriction on the loop bandwidth and should be used with care. 2 kΩ for R3\_LF and R4\_LF is a good starting point. If the integrated loop filter restricts the loop bandwidth, then first try to relieve this restriction by reducing the integrated loop filter resistors and then reduce the capacitors only if necessary.

### 9.3.20 Internal VCO Digital Calibration Time

When the LMX2541 is used in full chip mode, the integrated VCO can impact the lock time of the system. This digital calibration chooses the closest VCO frequency band, which typically gets the device within a frequency error 10 MHz or less of the final settling frequency, although this final frequency error can change slightly between the different options of the LMX2541. Once this digital calibration is finished, this remaining frequency error must settle out, and this remaining lock time is dictated by the loop bandwidth.

Based on measured data, this digital calibration time can be approximated by the following formula:

$$\text{LockTime} = A + B/\text{CLK} + C \cdot \Delta F + D \cdot (\Delta F/\text{CLK}) \quad (7)$$

SYMBOL1	VALUE	UNITS
Locktime	Varies	μs
A	30	μs
B	3800	None
C	0.1	us/MHz
D	2	μs
ΔF	Varies	MHz
CLK	$f_{\text{OSCin}} / 2$ for $0 \leq \text{OSC\_FREQ} \leq 63$ $f_{\text{OSCin}} / 4$ for $64 \leq \text{OSC\_FREQ} \leq 127$ $f_{\text{OSCin}} / 8$ for $128 \leq \text{OSC\_FREQ}$	None

For example, consider the LMX2541SQ3320E changing from 3600 to 3400 with an OSCin frequency of 100 MHz. In this case, ΔF = 200 (direction of frequency change does not matter),  $f_{\text{OSCin}} = 100$  MHz, and OSC\_FREQ=100. The calibration circuitry is run at a clock speed of CLK = 100 MHz / 4 = 25 MHz. When this values are substituted in the formula, the resulting lock time is 218 μs. After this time, the VCO will be within about 10 MHz of the final frequency and this final frequency error will settle out in an analog fashion. This final frequency error can be slightly different depending on which option of the LMX2541 is being used.

## 9.4 Device Functional Modes

### 9.4.1 External VCO Mode

The LMX2541 also has provisions to be driven with an external VCO as well. In this mode, the user has the option of using the RFout pin output, although if this pin is used, the VCO input frequency is restricted to 4 GHz. If not used, the RFout pin should be left open. The VCO input is connected to the ExtVCOin pin. Because the internal VCO is not being used, the part option that is being used does not have a large impact on phase noise or spur performance. It is also possible to switch between both Full Chip mode and External VCO mode.

### 9.4.2 Digital FSK Mode

The LMX2541 supports 2-level digital frequency shift keying (FSK) modulation. The bit rate is limited by the loop bandwidth of the PLL loop. As a general rule of thumb, it is desirable to have the loop bandwidth at least twice the bit rate. This is achieved by changing the N counter rapidly between two states. The fractional numerator and denominator are restricted to a length of 12 bits. The 12 LSB's of the numerator and denominator set the center frequency, Fcenter, and the 10 MSB's of the numerator set the frequency deviation, Fdev. The LMX2541 has the ability to switch between two different numerator values based on the voltage at the DATA pin. When DATA is low, the output frequency will be Fcenter – Fdev and when the DATA pin is high the output frequency will be Fcenter + Fdev. A limitation of the FSK mode is the frequency deviation cannot cause the N counter to cross integer boundaries. When using FSK mode, the FDM bit needs to be set to zero.

## 9.5 Programming

There are several other considerations for programming:

- The DATA is clocked into a shift register on each rising edge of the CLK signal. On the rising edge of the LE signal, the data is sent from the shift registers to an actual counter.
- A slew rate of at least 30 V/μs is recommended for the CLK, DATA, and LE signals.
- After the programming is complete, the CLK, DATA, and LE signals should be returned to a low state.
- When using the part in Full Chip Mode with the Integrated VCO, LE should be kept high no more than 1 us after the programming of the R0 register. Failure to do so may interfere with the digital VCO calibration.
- If the CLK and DATA lines are toggled while the in VCO is in lock, as is sometimes the case when these lines are shared with other parts, the phase noise may be degraded during the time of this programming.

### 9.5.1 General Programming Information

The LMX2541 is programmed using several 32-bit registers used to control the LMX2541 operation. A 32-bit shift register is used as a temporary register to indirectly program the on-chip registers. The shift register consists of a data field and an address field. The last 4 register bits, CTRL[3:0] form the address field, which is used to decode the internal register address. The remaining 28 bits form the data field DATA[27:0]. While LE is low, serial data is clocked into the shift register upon the rising edge of clock (data is programmed MSB first). When LE goes high, data is transferred from the data field into the selected register bank. For initial device programming the register programming sequence must be done in the order as shown in the register map. The action of programming register R7 and bringing LE low resets all the registers to default values, including hidden registers. The programming of register R0 is also special for the device when operating in full chip mode because the action of programming either one of these registers activates the VCO calibration.

In addition to changing the values of various words, the programming of certain registers triggers certain events as described in the table below:

PROGRAMMING EVENT	EVENT TRIGGERED	CONFIGURATIONS WHERE IT HAS AN IMPACT	SIGNIFICANCE
Action of programming register R7 and bring LE low	Resets all registers, including hidden ones, to a default state	All	This needs to be the first programming step for all configurations. If register R7 is ever programmed again, all programming information will be reset to the default state.
Action of programming register R0 and bringing LE low	Activates the VCO calibration	Only in Full Chip Mode	The VCO calibration tunes the VCO to the correct frequency band and optimizes the phase noise. It is necessary whenever the internal VCO frequency is changed. Also, if the temperature drifts considerably, then this calibration can better optimize the phase noise.
Action of programming register R4	Synchronizes the VCO Divider	Only when the RFout pin ins enabled and the VCO divider is set to 4 or 5	Consult the <a href="#">Feature Description</a> for more details.

**LMX2541**

SNO5B31J – JULY 2009 – REVISED DECEMBER 2014

[www.ti.com](http://www.ti.com)
**9.6 Register Maps**

The following table lists the registers as well as the order that they should be programmed. Register 7 is programmed first and the action of programming register R7 resets all the registers after the LE pin is pulled to a low state. Register R0 is programmed last because it activates the VCO calibration. The one exception to this is when the VCO\_DIV value is 4 or 5. Consult the programming section on VCO\_DIV for more details.

**Table 18. Register Map**

	31	30	29	28	27	26	25	24	23	22	21	20	19	18	17	16	15	14	13	12	11	10	9	8	7	6	5	4	3	2	1	0
	DATA[27:0]																											C3	C2	C1	C0	
R7	0	0	0	0	0	0	0	0	0	0	0	0	0	0	0	0	0	0	0	0	0	0	0	0	0	0	0	1	0	1	1	1
R13	0	0	0	0	0	0	0	0	0	0	0	0	0	0	0	0	0	0	0	0	0	0	0	0	1	VCO_DIV_OPT [2:0]		1	1	0	1	
R12	0	0	0	0	0	0	0	0	0	0	0	0	0	0	0	0	0	0	0	0	0	0	0	0	0	0	0	1	1	1	0	0
R9	0	0	1	0	1	0	0	0	0	0	0	0	0	0	0	0	0	0	0	1	0	1	0	0	0	0	0	0	1	0	0	1
R8	0	0	0	0	0	0	0	1	0	0	0	1	0	0	0	1	1	1	0	0	1	1	1	AC_TEMP_COMP[4:0]			1	0	0	0		
R6	0	0	0	0	0	0	0	0	0	0	0	1	1	VCOGAIN[3:0]			OUTTERM[3:0]			DIVGAIN[3:0]			RFOUT[1:0]		0	1	1	0				
R5	1	0	1	FL_CPG[4:0]				FL_RF_LF[2:0]		FL_R3_LF[2:0]		FL_TOC[13:0]							0	1	0	1										
R4	C4_LF[3:0]			C3_LF[3:0]			R4_LF[2:0]		R3_LF[2:0]		VCO_DIV[5:0]				OSC_FREQ[7:0]				0	1	0	0										
R3	FSK	0	0	DLOCK[2:0]		CP T	DITH[1:0]	ORDER[2:0]		FD M	OS C _2X	CP P	MUX[3:0]		CPG[4:0]			XO	PO WE R DO WN	MODE[1:0]		0	0	1	1							
R2	0	0	0	0	0	1	DEN[21:0]										0	0	1	0												
R1	0	0	0	0	PLL_NUM[21:16]					PLL_N[17:12]					PLL_R[11:0]					0	0	0	1									
R0	PLL_NUM[15:0]										PLL_N[11:0]							0	0	0	0											

## 9.6.1 Register R7

Although Register 7 has no elective bits to program, it is very important to program this register because the action of doing so with the bit sequence shown in the register map resets all the registers, including hidden registers with test bits that are not disclosed. Register 7 should always be programmed first, because it will reset all other programming information. The register reset occurs only after the LE signal has transitioned from low to high and back to low again.

### 9.6.1.1 Register R13

This register needs to be programmed only in the event that the RFout pin is being used and VCO\_DIV = 1.

#### 9.6.1.1.1 VCO\_DIV\_OPT[2:0]

This word optimizes the RFout power level based on the VCO\_DIV and VCO\_GAIN words.

CONDITION	VCO_DIV_OPT	COMMENTS
RFout Pin Disabled OR VCO_DIV>1 OR VCO_GAIN<13	0	Register R13 Does Not need to be programmed, because 0 is the default.
RFout Pin Enabled AND VCO_DIV=1 VCO_GAIN>12	4	

### 9.6.1.2 Register R12

This register needs to be programmed as shown in the register map in the event that the internal VCO is being used. When using external VCO mode, this register does not need to be programmed.

### 9.6.1.3 Register R9

Program this register as shown in the register map.

### 9.6.1.4 Register R8

#### 9.6.1.4.1 AC\_TEMP\_COMP[4:0]

This word optimizes the VCO phase noise for possible temperature drift. When the VCO frequency is changed, the internal tuning algorithm optimizes the phase noise for the current temperature. In fixed frequency applications, temperature drift may lead to sub-optimal phase noise over time. In dynamic frequency applications, the re-tuning of the VCO frequency overcomes this problem because the phase noise is re-optimized each time the VCO frequency is changed. The AC\_TEMP\_COMP word can be used to optimize the VCO phase noise for temperature drift for these different scenarios. The following table indicates which values of this word should be used for each scenario.

AC_TEMP_COMP	APPLICATION TYPE
5	Dynamic Frequency
24	Fixed Frequency
All Other States	Invalid

### 9.6.1.5 Register R6

Register R6 has words that impact the output power of the RFout pin.

#### 9.6.1.5.1 RFOUT[1:0] - RFout enable pin

This word works in combination with the RFoutEN Pin to control the state of the RFout pin.

RFOUT	RFoutEN PIN	RFout PIN STATE
0	Don't Care	Disabled
2	Don't Care	Enabled
1 or 3	Low	Disabled
	High	Enabled

#### 9.6.1.5.2 DIVGAIN[3:0], VCOGAIN[3:0], and OUTTERM[3:0] - Power Controls for RFout

These three words may be programmed in a value from 0 to 15 and work in conjunction to control the output power level of the RFout pin. Increasing any of these values increases the output power at the expense of higher current consumption of the buffer. Although there may be more than one way to get the same output power, some combinations may have lower current. The typical performance characteristics show these trade-offs. The default setting for all these bits is 12. The value of VCO\_DIV determines which two of these three words have an impact.

VCO_DIV	BITS that IMPACT POWER
1 (Bypass)	OUTTERM, VCOGAIN
>1 (Not Bypass)	OUTTERM, DIVGAIN

### 9.6.1.6 Register R5

This register controls the fastlock mode which enables a wider loop bandwidth when the device is changing frequencies.

#### 9.6.1.6.1 FL\_TOC[13:0] -- Time Out Counter for FastLock

When the value of this word is 3 or less, FastLock time out counter is disabled, and the FLout pin can be used for general purpose I/O. When this value is 4 or greater, the time out counter is engaged for the amount of phase detector cycles shown in the table below.

TOC VALUE	FLout PIN STATE	FASTLOCK ENGAGEMENT TIME
0	High Impedance	Disabled
1	Low	Always Engaged
2	Low	Disabled
3	High	Disabled
4	Low	Engaged for 4 x 2 Phase Detector Cycles
.	.	.
16383	Low	Engaged for 16383 x 2 Phase Detector Cycles

When this count is active, the FLout Pin is grounded, the FastLock current is engaged, and the resistors R3 and R4 are also potentially changed. The table below summarizes the bits that control various values in and out of FastLock.

FastLock STATE	FLout	CHARGE PUMP CURRENT	R3_LF VALUE	R4_LF VALUE
Not Engaged	High Impedance	CPG	R3_LF	R4_LF
Engaged	Grounded	FL_CPG	FL_R3_LF	FL_R4_LF

**9.6.1.6.2 FL\_R3\_LF[2:0] -- Value for Internal Loop Filter Resistor R3 During Fastlock**

FL_R3_LF VALUE	R3 RESISTOR DURING FASTLOCK (k $\Omega$ )
0	Low ( 200 $\Omega$ )
1	1
2	2
3	4
4	16
5-7	Reserved

**9.6.1.6.3 FL\_R4\_LF[2:0] -- Value for Internal Loop Filter Resistor R4 During Fastlock**

FL_R4_LF VALUE	R3 RESISTOR DURING FASTLOCK (k $\Omega$ )
0	Low ( 200 $\Omega$ )
1	1
2	2
3	4
4	16
5-7	Reserved

**9.6.1.6.4 FL\_CPG[4:0] -- Charge Pump Current for Fastlock**

When FastLock is enabled, this is the charge pump current that is used for faster lock time.

FL_CPG	FASTLOCK CHARGE PUMP STATE	TYPICAL FASTLOCK CHARGE PUMP CURRENT at 3.3 VOLTS ( $\mu$ A)
0	1X	100
1	2X	200
2	3X	300
3	4X	400
...	...	...
31	32X	3200

**9.6.1.7 Register R4**

This register controls miscellaneous functions of the device. The action of programming the R4 register also synchronizes the VCO divider, which is necessary when VCO\_DIV = 4 or 5.

**9.6.1.7.1 OSC\_FREQ [7:0] -- OSCin Frequency for VCO Calibration Clocking**

This word is used for the VCO frequency calibration. This word should be set to the OSCin frequency rounded to the nearest MHz.

OSC_FREQ	OSCin FREQUENCY
0	Illegal State
1	1 MHz
2	2 MHz
...	...
255	255 MHz and higher

**9.6.1.7.2 VCO\_DIV[5:0] - VCO Divider**

The output of the VCO is divided by the value of VCO\_DIV, which can range from 1 (Bypass Mode) to 63 and all values in between with the limitation that the VCO divider can only be set to bypass mode when the device is operating in full chip mode. When the VCO divider is set to 4 or 5 ONLY, there is one extra programming step required to synchronize the VCO divider. Consult the [Feature Description](#) for more details.

VCO_DIV	VCO OUTPUT DIVIDE	COMMENTS
0	n/a	Illegal State
1	Bypass Mode	This state only available for MODE=Full Chip Mode
2	Divide by 2	
3	Divide by 3	
4	Divide by 4	Extra programming is required for divide by 4 and divide by 5 only. Refer to the <a href="#">Feature Description</a> for more details.
5	Divide by 5	
6	Divide by 6	
...	...	
62	Divide by 62	
63	Divide by 63	

**9.6.1.7.3 R3\_LF[2:0] -- Value for Internal Loop Filter Resistor R3**

This word controls the state of the internal loop filter resistor R3\_LF when the device is in Full Chip Mode and Fastlock is not active.

R3_LF VALUE	R3 RESISTOR DURING FASTLOCK (k $\Omega$ )
0	Low ( 200 $\Omega$ )
1	1
2	2
3	4
4	16
5-7	Reserved

**9.6.1.7.4 R4\_LF[2:0] -- Value for Internal Loop Filter Resistor R4**

This word controls the state of the internal loop filter resistor R4\_LF when the device is in Full Chip Mode and Fastlock is not active.

R4_LF VALUE	R3 RESISTOR DURING FASTLOCK (k $\Omega$ )
0	Low ( 200 $\Omega$ )
1	1
2	2
3	4
4	16
5-7	Reserved

**9.6.1.7.5 C3\_LF[3:0] -- Value for C3 in the Internal Loop Filter**

This word controls the state of the internal loop filter resistor C3\_LF when the device is Full Chip Mode.

C3_LF	C3 (pF)
0	0
1	1
2	5
3	6
4	10
5	11
6	15
7	16
8	20
9	21
10	25
11	26
12	30
13	31
14	35
15	36

**9.6.1.7.6 C4\_LF[3:0] -- Value for C4 in the Internal Loop Filter**

This word controls the state of the internal loop filter resistor C4\_LF when the device is Full Chip Mode.

C4_LF	C4 (pF)
0	0
1	5
2	20
3	25
4	40
5	45
6	60
7	65
8	100
9	105
10	120
11	125
12	140
13	145
14	160
15	165

**LMX2541**

SNOSB31J – JULY 2009 – REVISED DECEMBER 2014

[www.ti.com](http://www.ti.com)
**9.6.1.8 Register R3**

This register controls miscellaneous features of the device.

**9.6.1.8.1 MODE[1:0] -- Operational Mode**

The LMX2541 can be run in several operational modes as listed in the table below:

MODE	NAME	DIVIDER	PLL	VCO
0	Full	Enabled	Enabled	Enabled
1	External VCO	Enabled	Enabled	Disabled
2	Divider Only	Enabled	Disabled	Disabled
3	Test (Reserved)	Enabled	Enabled	Enabled

**9.6.1.8.2 Powerdown -- Powerdown Bit**

Enabling this bit powers down the entire device, although register and VCO calibration information is retained.

**9.6.1.8.3 XO - Crystal Oscillator Mode Select**

When this bit is enabled, a crystal with appropriate load capacitors can be attached between the OSCin and OSCin\* pins in order to form a crystal oscillator.

**9.6.1.8.4 CPG[4:0] -- Charge Pump Current**

This word programs the charge pump current gain. The current is programmable between 100 uA and 3.2 mA in 100 uA steps.

CPG	CHARGE PUMP STATE	TYPICAL CHARGE PUMP CURRENT ( $\mu$ A)
0	1X	100
1	2X	200
2	3X	300
3	4X	...
...	...	
31	32X	3200

### 9.6.1.8.5 MUX[3:0] -- Multiplexed Output for Ftest/LD Pin

The MUX[3:0] word is used to program the output of the Ftest/LD Pin. This pin can be used for a general purpose I/O pin, a lock detect pin, and for diagnostic purposes. When programmed to the digital lock detect state, the output of the Ftest/LD pin will be high when the device is in lock, and low otherwise. The output voltage level of the Ftest/LD is not equal to the supply voltage of the device, but rather is given by  $V_{OH}$  and  $V_{OL}$  in the electrical characteristics specification.

Because the Ftest/LD pin is close to the OSCin pin, the state of this pin can have an impact on the performance of the device. If any of the diagnostic modes (8-13) are used, the OSCin sensitivity can be severely degraded, so these should only be used for diagnostic purposes. The fractional spurs can also be impacted a little by the MUX programming word. The Push-Pull digital lock detect modes, like mode 3, tend to have the best fractional spurs, so these states are recommended, even if the digital lock detect function is not needed.

MUX	OUTPUT TYPE	FUNCTION	COMMENTS
0	High Impedance	Disabled	<b>GENERAL PURPOSE I/O MODES</b>
1	Push-Pull	Logical High State	
2	Push-Pull	Logical Low State	
3	Push-Pull	Digital Lock Detect	<b>LOCK DETECT MODES</b> Consult <a href="#">Feature Description</a> for more details State 3 is recommended for optimal spurious performance.
4	Push-Pull	Inverse Digital Lock Detect	
5	Open Drain	Digital Lock Detect	
6	Open Drain	Analog Lock Detect	
7	Push-Pull	Analog Lock Detect	<b>DIAGNOSTIC MODES</b> These allow the user to view the outputs of the N divider, R divider, and phase frequency detector (PFD) and are intended only for diagnostic purposes. Typically, the output is narrow pulses, but when the output is divided by 2, there is a 50% duty cycle. The use of these modes (including R Divider) can degrade the OSCin sensitivity.
8	Push-Pull	N Divider	
9	Push-Pull	N Divider / 2	
10	Push-Pull	R Divider	
11	Push-Pull	R Divider / 2	
12	Push-Pull	PFD Up	
13	Push-Pull	PFD Down	
14-15	N/A	Reserved	

### 9.6.1.8.6 CPP - Charge Pump Polarity

This bit sets the polarity of the phase detector.

CPP	CHARGE PUMP POLARITY	TYPICAL APPLICATIONS
0	Negative	Full Chip Mode External VCO Mode with an inverting active loop filter.
1	Positive	External VCO Mode with a passive loop filter.

### 9.6.1.8.7 OSC2X-- OSCin Frequency Doubler

Enabling this bit doubles the OSCin frequency. This is useful in achieving a higher phase detector frequency to improve PLL phase noise, push out noise from the delta-sigma modulator, and sometimes reduce fractional spurs. Note that when this bit is enabled, the R divider is bypassed.

OSC_2X	STATE
0	Normal
1	OSCin frequency is doubled

**9.6.1.8.8 FDM - Extended Fractional Denominator Mode Enable**

Enabling this bit allows the fractional numerator and denominator to be expanded from 10 bits to 22 bits. In 10-bit mode, only the first 10 bits of the fractional numerator and denominator are considered. When using FSK mode, this bit has to be disabled.

FDM	FRACTIONAL MODE
0	10-bit
1 (Default)	22-bit

**9.6.1.8.9 ORDER[2:0] -- Delta-Sigma Modulator Order**

This word determines the order of the delta-sigma modulator in the PLL. In general, higher order fractional modulators tend to reduce the primary fractional spurs that occur at increments of the channel spacing, but can also create spurs that are at a fraction of the channel spacing. The optimal choice of modulator order is very application specific, however, a third order modulator is a good starting point. The first order modulator has no analog compensation or dithering

ORDER	DELTA-SIGMA MODULATOR	MODE	COMMENTS
0	Disabled	Integer	Allows larger N Counter
1	First Order	Fractional	This has no analog compensation or dithering
2	Second Order		Traditional Delta-Sigma Operation
3	Third Order		
4	Fourth Order		
5-7	Illegal States	n/a	n/a

**9.6.1.8.10 DITH[1:0] -- Dithering**

Dithering randomizes the delta-sigma modulator output. This reduces sub-fractional spurs at the expense of adding phase noise. In general, it is recommended to keep the dithering strength at None or Weak for most applications. Dithering should never be used when the device is used in integer mode or a first order modulator. When using dithering with the other delta-sigma modulator orders, it is beneficial to disable it in the case where the fractional numerator is zero, because it can actually create sub-fractional spurs.

DITH	DITHERING STRENGTH
0	Weak
1	Medium
2	Strong
3	Disabled

**9.6.1.8.11 CPT - Charge Pump TRI-STATE**

When this bit is enabled, the charge pump is at TRI-STATE. The TRI-STATE mode could be useful for open loop modulation applications or as diagnostic tool for measuring the VCO noise, but is generally not used.

CPT	CHARGE PUMP
0	Normal Operation
1	TRI-STATE

### 9.6.1.8.12 DLOCK[2:0] - Controls for Digital Lock Detect

This word controls operation of the digital lock detect function through selection of the window sizes ( $\epsilon$  and  $\delta$ ). In order to indicate the PLL is locked, there must be 5 consecutive phase detector output cycles in which the time offset between the R and N counter outputs is less than  $\epsilon$ . This will cause the Ftest/LD pin output to go high. Once lock is indicated, it will remain in this state until the time offset between the R and N counter outputs exceeds  $\delta$ . For this device,  $\epsilon$  and  $\delta$  are the same. If the OSCin signal goes away, the digital lock detect circuit will reliably indicate an unlocked condition. Consult the [Feature Description](#) for more details. A larger window size makes the lock detect circuit less sensitive, but may be necessary in some situations to reduce chattering.

DLOCK	WINDOW SIZE ( $\epsilon$ and $\delta$ )
0 (Default)	3.5
1	5.5
2	7.5
3	9.5
4	11.5
5	13.5
6 -7	Reserved

There are restrictions when using digital lock detect, based on the phase detector frequency ( $f_{PD}$ ), Modulator Order (ORDER), and VCO frequency ( $f_{VCO}$ ). The first restriction involves a minimum window size ( $\epsilon_{min}$ ), the second one involves a maximum window size ( $\epsilon_{max}$ ), and the third involves further restrictions on the maximum phase detector frequency that are implied by the window size that is selected.

The first restriction involves the minimum window size ( $\epsilon_{min}$ ). This minimum window size cannot be greater than the maximum programmable value of 13.5 ns for valid operation of the digital lock detect. Possible remedies for this solution would be reducing the delta-sigma order, using a higher VCO frequency and using a larger VCO\_DIV value, or using analog lock detect.

$$13.5 \text{ ns} \geq \epsilon_{min} = 2^{\text{ORDER}-1} / f_{VCO} \quad (8)$$

The second restriction is the maximum window size ( $\epsilon_{max}$ ). If the calculated maximum window size is less than the minimum programmable window size of 3.5 ns, then this indicates that the digital lock detect cannot be used in this condition. Possible remedies for this could be to decrease the phase detector frequency, use analog lock detect, decrease the delta-sigma order, or decrease the VCO frequency.

$$3.5 \text{ ns} \leq \epsilon_{max} = 1/f_{PD} - \epsilon_{min} - 2 \text{ ns} \quad (9)$$

The third restriction comes from rearranging the equation for  $\epsilon_{max}$ .

$$f_{PD} \leq 1 / ( \epsilon_{min} + \epsilon_{max} + 2 \text{ ns} ) \quad (10)$$

In addition to this restriction on the maximum phase detector rate, recall that there are also restrictions on the maximum phase detector rate implied by the electrical specifications (  $f_{PD} \leq 104 \text{ MHz}$  ) and by the minimum continuous N divider value (  $f_{PD} \leq f_{VCO} / N_{Min}$  ).

f <sub>VCO</sub> (MHz)	ORDER	ε <sub>min</sub> (ns)	MAXIMUM POSSIBLE PHASE DETECTOR FREQUENCY (MHz)					
			ε = 3.5 ns	ε = 5.5 ns	ε = 7.5 ns	ε = 9.5 ns	ε = 11.5 ns	ε = 13.5 ns
All	0	0.0	Min (104, f <sub>VCO</sub> / 12)	Min (104, f <sub>VCO</sub> / 12)	Min (104, f <sub>VCO</sub> / 12)	Min (87.0, f <sub>VCO</sub> / 12)	Min (74.1, f <sub>VCO</sub> / 12)	Min (64.5, f <sub>VCO</sub> / 12)
400	4	20.0	FAIL	FAIL	FAIL	FAIL	FAIL	FAIL
400	3	10.0	FAIL	FAIL	FAIL	FAIL	26.7	26.7
400	2	5.0	FAIL	30.8	30.8	30.8	30.8	30.8
500	4	16.0	FAIL	FAIL	FAIL	FAIL	FAIL	FAIL
500	3	8.0	FAIL	FAIL	FAIL	33.3	33.3	33.3
500	2	4.0	FAIL	38.5	38.5	38.5	38.5	38.5
600	4	13.3	FAIL	FAIL	FAIL	FAIL	FAIL	31.6
600	3	6.7	FAIL	FAIL	40.0	40.0	40.0	40.0
600	2	3.3	46.2	46.2	46.2	46.2	46.2	46.2
1200	4	6.7	FAIL	FAIL	63.2	63.2	63.2	63.2
1200	3	3.3	80.0	80.0	80.0	80.0	74.1	64.5
1200	2	1.7	92.3	92.3	92.3	87.0	74.1	64.5
1530	4	5.2	FAIL	80.3	80.3	80.3	74.1	64.5
1530	3	2.6	102.0	102.0	102.0	87.0	74.1	64.5
1530	2	1.3	104.0	104.0	104.0	87.0	74.1	64.5
1800	4	4.4	FAIL	91.8	91.8	87.0	74.1	64.5
1800	3	2.2	104.0	104.0	104.0	87.0	74.1	64.5
1800	2	1.1	104.0	104.0	104.0	87.0	74.1	64.5
2000	4	4.0	FAIL	100.0	100.0	87.0	74.1	64.5
2000	3	2.0	104.0	104.0	104.0	87.0	74.1	64.5
2000	2	1.0	104.0	104.0	104.0	87.0	74.1	64.5
3000	4	2.7	104.0	104.0	104.0	87.0	74.1	64.5
3000	3	1.3	104.0	104.0	104.0	87.0	74.1	64.5
3000	2	0.7	104.0	104.0	104.0	87.0	74.1	64.5
4000	4	2.0	104.0	104.0	104.0	87.0	74.1	64.5
4000	3	1.0	104.0	104.0	104.0	87.0	74.1	64.5
4000	2	0.5	104.0	104.0	104.0	87.0	74.1	64.5

In the previous table, consider the case of operating in integer mode with ORDER=0. For this case, lock detect can theoretically work for all VCO frequencies provided that the phase detector frequency does not violate the maximum possible value. For instance, it would be an invalid condition to operate in integer mode with a VCO frequency of 900 MHz and a phase detector frequency of 100 MHz because 100 MHz exceeds the limit of 900 MHz/12 = 75 MHz. If the phase detector was lowered to 75 MHz to meet this restriction, then this condition would be valid provided that the window size was programmed to be 9.5 ns or less.

Consider another example of a 400 MHz VCO frequency with a fourth order modulator. Because the minimum window size of 20 ns is above the maximum programmable value of 13.5 ns, digital lock detect cannot be used in this configuration. If the modulator order was reduced to 2nd order, then it would function provided that the phase detector frequency was less 30.8 MHz.

#### 9.6.1.8.13 FSK - Frequency Shift Keying

This bit enables a binary FSK modulation mode using the PLL N counter. Consult the applications section for more details.

FSK	FSK MODE
0	Disabled
1	Enabled

### 9.6.1.9 Register R2

This word contains all the bits of the fractional denominator. These bits apply if the device is being used fractional mode.

#### 9.6.1.9.1 PLL\_DEN[21:0] -- Fractional Denominator

These bits determine the fractional denominator.

	PLL_DEN[21:0]																				
Fractional Denominator																					
0	0	0	0	0	0	0	0	0	0	0	0	0	0	0	0	0	0	0	0	0	0
...	.	.	.	.	.	.	.	.	.	.	.	.	.	.	.	.	.	.	.	.	.
4194303	1	1	1	1	1	1	1	1	1	1	1	1	1	1	1	1	1	1	1	1	1

### 9.6.1.10 Registers R1 and R0

Both registers R1 and R0 contain information for the PLL R counter, N counter, and fractional numerator. The action of programming register R0, even to the same value, runs the VCO calibration when the device has the internal VCO operating. There are some programming words that are split across these two registers.

#### 9.6.1.10.1 PLL\_R[11:0] -- PLL R Divider Value

The R divider divides the OSCin signal. Note that if the doubler is enabled, the R divider is bypassed.

	PLL_R[11:0]											
0	Illegal State											
1	0	0	0	0	0	0	0	0	0	0	0	1
2	0	0	0	0	0	0	0	0	0	0	1	0
3	0	0	0	0	0	0	0	0	0	0	1	1
...	...	...	...	...	...	...	...	...	...	...	...	...
4095	1	1	1	1	1	1	1	1	1	1	1	1

#### 9.6.1.10.2 PLL\_N[17:0] PLL N Divider Value

When using integer mode, the PLL N divider value is split up into two different locations. In fractional mode, only the 12 LSB bits of the N counter are used. Based on the order of the modulator, the range is shown in the table below.

		PLL_N[17:12]						PLL_N[11:0]												
<12	Integer Mode	Divide Values below 12 are prohibited																		
12		0	0	0	0	0	0	0	0	0	0	0	0	0	0	1	1	0	0	
13		0	0	0	0	0	0	0	0	0	0	0	0	0	0	1	1	0	1	
...		.	.	.	.	.	.	.	.	.	.	.	.	.	.	.	.	.	.	
262143		1	1	1	1	1	1	1	1	1	1	1	1	1	1	1	1	1	1	
12	Fractional Mode	Possible with first order modulator only																		
13-14		Possible with first or second order modulator																		
15-18		Possible with first, second, or third order modulators only																		
19		x	x	x	x	x	x	0	0	0	0	0	0	0	0	1	0	0	1	1
...		.	.	.	.	.	.	.	.	.	.	.	.	.	.	.	.	.	.	
4087		x	x	x	x	x	x	1	1	1	1	1	1	1	1	0	1	1	1	
4088-4091		Possible with a first, second, or third order modulator only																		
4092-4093		Possible with a first or second order modulator only																		
4094		Possible with a first order modulator only																		

**LMX2541**

SNOSB31J – JULY 2009 – REVISED DECEMBER 2014

[www.ti.com](http://www.ti.com)

Note that the N divider value has a minimum value,  $N_{Min}$ , which is implied by the modulator order.  $N_{Min}$  is 12 for integer mode and a first order modulator, 13 for a 2nd order modulator, 15 for a third order modulator, and 19 for a fourth order modulator. The maximum phase detector frequency given the electrical specifications, modulator order, and VCO frequency is shown below.

$$f_{PD} \leq \text{Min}(104 \text{ MHz}, f_{VCO} / N_{Min}) \quad (11)$$

**9.6.1.10.3 PLL\_NUM[21:0] -- Fractional Numerator**

The fractional numerator is formed by the NUM word that is split between two registers and applies in fractional mode only. The fractional numerator, PLL\_NUM must be less than or equal to the fractional denominator, PLL\_DEN.

FRACTIONAL NUMERATOR	PLL_NUM[21:16]						PLL_NUM[15:0]															
	0	0	0	0	0	0	0	0	0	0	0	0	0	0	0	0	0	0	0	0	0	0
0	0	0	0	0	0	0	0	0	0	0	0	0	0	0	0	0	0	0	0	0	0	0
...																						
4194303	1	1	1	1	1	1	1	1	1	1	1	1	1	1	1	1	1	1	1	1	1	1

## 10 Application and Implementation

### NOTE

Information in the following applications sections is not part of the TI component specification, and TI does not warrant its accuracy or completeness. TI's customers are responsible for determining suitability of components for their purposes. Customers should validate and test their design implementation to confirm system functionality.

### 10.1 Application Information

#### 10.1.1 Determining the Best Frequency Option of the LMX2541 to Use

When there are multiple devices that can satisfy the frequency requirement, performance characteristics can sometimes be used to make a decision. Consider the following example of where an output frequency of 1200 to 1250 MHz is desired with a channel spacing of 100 kHz. From the frequency table, the LMX2541SQ2380E could be used with a divide value of 2, or the LMX2541SQ3740E option could be used with a divide value of 3. This raises the question: Which one has better performance? The following table is helpful in comparing the performance.

PERFORMANCE CHARACTERISTIC	WHAT MAKES IT BETTER	WHY
Fractional Spurs and Fraction Noise	Larger Value of VCO_DIV	Fractional spurs at the VCO are independent of VCO frequency, but when the VCO frequency is divided down by a factor of VCO_DIV, the fractional spurs improve by a factor of $20 \cdot \log(\text{VCO\_DIV})$ . Also, the fractional channel spacing can be made wider at the VCO, which makes the fractional spurs farther from the carrier. The fractional noise of the modulator is divided down in a similar way as fractional spurs. In applications where this is dominant, this larger division can have an impact. Consult the applications section for more information on the fractional phase noise.
VCO Phase Noise	Operating in the lower frequency range of the VCO	At the lower end of the tuning range, the VCO phase noise is less because the tuning gain is less. This provides better phase noise, even accounting for the difference in frequency.

Considering the fractional spurs and phase noise, the channel spacing at the 2380E VCO would be 200 kHz. When this is divided by two, the offset of these spurs does not change and the spurs at the VCO output would be reduced by a factor of  $20 \cdot \log(2) = 6$  dB. The channel spacing at the 3740E VCO would be 300 kHz and these spurs would be reduced by a factor of  $20 \cdot \log(3) = 9.5$  dB. So the spurs of the 3740E option would probably be better by virtue of the fact that they are farther from the carrier and easier to filter and also that they are divided down more by the VCO divider. The fractional phase noise would also be  $(9.5 - 6) = 3.5$  dB better by the same reasoning.

Now consider the VCO phase noise. For the 3740E option, 1200 - 1250 MHz corresponds to a VCO frequency of 3600 - 3750 MHz, which is closer to the lower end of the tuning range for this device. For the 2380E option, this would correspond to 2400 - 2500 MHz, which is closer to the higher end of the tuning range. To verify this, take the phase noise numbers from the electrical specifications, extrapolate them to the actual frequencies, and then subtract a factor of  $20 \cdot \log(\text{VCO\_DIV})$ . For the 2380E option, this works out to -116 dBc/Hz at 1200 MHz and -115.4 dBc/Hz at 1250 MHz. For the 3740E option, this works out to -117.4 dBc/Hz at 1200 MHz and -116.9 dBc/Hz at 1250 MHz.

### 10.1.2 RFout Output Power Test Setup

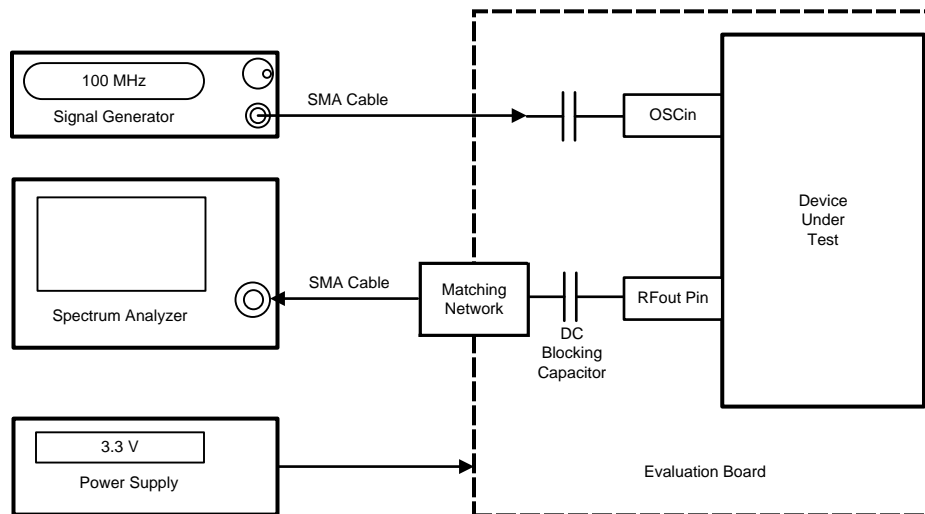

The output power is tested by programming the VCO output to a desired frequency and measuring with a spectrum analyzer. A 3 dB pad is used and this gain as well as any losses from the cable are added to the actual measurement. As for the DC blocking capacitor, typically 100 pF is used for frequencies above 2 GHz and 0.1 uF are used for frequencies below 2 GHz. It turns out that the measurement is not as sensitive as one would expect to this blocking capacitor value. The output power is mainly a function of the frequency of the output buffer and the settings of the VCO\_DIV (1 or >1), OUTTERM, VCOGAIN, and DIVGAIN bits. It is not very sensitive to the actual frequency option of the part. For instance, the LMX2541SQ2060E and the LMX2541SQ2380E both should have similar output power at 2.2 GHz. Note that this same test setup can also be used to measure harmonics.

### 10.1.3 Phase Noise Measurement Test Setup

The basic setup technique for all noise tests is to measure the noise at the output of the RFout pin in Internal VCO Mode (MODE=0) with a phase noise analyzer. For all measurements, the internal loop filter components (LF\_R3, LF\_R4, LF\_C3, and LF\_C4) should be set to their minimum values. There are some special considerations depending on what kind of noise is being measured.

#### 10.1.3.1 PLL Phase Noise Measurement

To get an accurate measurement of the PLL phase noise, one needs to ensure four things.

- The PLL loop bandwidth is sufficiently wide so that the VCO noise does not degrade the measurement
- The measurement is not corrupted by peaking in the loop filter response.
- The reference source is sufficiently clean so that this does not degrade the measurement.
- A distinction is made between the PLL flat noise and the PLL 1/f noise

If the PLL loop bandwidth is made as wide as possible, then this helps keep the peaking of the loop filter response and the VCO noise from degrading the measurement. For the ultimate accuracy, this loop filter response can be factored into the measurement. As for the cleanliness of the reference source, the best sources tend to be those that are fixed, such as a 100 MHz Wenzel oscillator. Signal generators tend to be noisy, but if that is all that is available, then there are a few things that can help compensate for this. One technique is to use a higher frequency and divide this down to a lower frequency. For instance, a 500 MHz signal divided down to 20 MHz typically has much better phase noise than a direct 20 MHz signal, if it comes from a signal generator. Another technique is to measure the noise of the reference source and then multiply it up and then subtract it from the measurement. For instance, if the signal source was 500 MHz and the output frequency was 4 GHz, this signal source noise would be multiplied up by a factor of  $20 \cdot \log(4 \text{ GHz} / 500 \text{ MHz}) = 18 \text{ dB}$ . Once that is done, the 1/f noise and the flat noise can be measured.

#### 10.1.3.1.1 PLL Phase Noise Measurement - 1/f Noise

The 1/f noise dominates closer to the carrier. Special care should be taken to ensure that this is not the noise of the reference source. The noise contribution of the reference source at the RFout pin can be calculated by measuring what is coming into the OSCin pin and then adding a correction factor of  $20 \cdot \log(f_{RFout} / f_{OSCin})$ . A characteristic of this noise is that it follows a 10 dB/decade slope. If the slope of the measured noise looks more than 10 dB/decade, it is likely to be the reference source, not the LMX2541 device. Another characteristic of the 1/f noise is that it is independent of phase detector frequency. So to fully expose the 1/f noise, raise the phase detector frequency as high as possible, because this lowers the flat noise, but not the 1/f noise.

#### 10.1.3.1.2 PLL Phase Noise Measurement - Flat Noise

The PLL flat noise is measured at an offset that is not too close to the PLL 1/f noise, but also well inside the loop bandwidth. Many phase noise profiles have a point where the PLL noise flattens to a minimum value between the carrier and the loop bandwidth. This is where the flat noise should be measured. To measure the 1 Hz normalized phase noise, it is often easier to measure this with a lower phase detector frequency so that this flat noise is higher and easier to measure.

#### 10.1.3.2 VCO Phase Noise Measurement

In order to measure the VCO phase noise, the loop filter resistors should be set to their minimum value to reduce their noise contribution. The loop bandwidth should also be made as narrow as possible. Because the loop bandwidth is very narrow, the cleanliness of the OSCin signal is therefore not as important. The phase noise is measured outside the loop bandwidth of the system.

An alternative way that might not be as accurate, but is much easier to do is to lock the device to a frequency and then set the CPT bit to 1 to disable the charge pump. The VCO will drift a little, the averaging on the equipment should be reset after this bit is changed and one cannot take too long to take this measurement. Test equipment that tracks the signal source is better if using this open loop technique.

#### 10.1.3.3 Divider Phase Noise Measurement

The basic method for measuring the divider noise is to drive the divider with a noise source of known value and then subtract away this noise. The divider noise floor tends to be flat, whereas the VCO phase noise decreases with offset frequency, so this measurement is made at as far of an offset that is possible. When using Internal VCO Mode (MODE=0), the raw VCO phase noise with VCO\_DIV=1 can be measured. Then the VCO divider can be programmed to get close to the desired frequency. For example, the VCO frequency can be set to 4 GHz and the phase noise measured. This phase noise data can be saved or downloaded. Suppose then that one was interested in the divider noise at 400 MHz. The VCO divider could be set to 10 and then 20 dB is subtracted from the VCO phase noise to figure its contribution at 400 MHz. Provided that the actual phase noise measured at 400 MHz with VCO\_DIV is above this, then one can assume that this is the noise of the divider.

An alternative way to measure this is to drive the OSCin pin and use Divider Only (MODE=2) to measure the phase noise. This gives direct control of the frequency, but one should be sure that the noise being measured is the device and not the frequency source.

### 10.1.4 Input and Output Impedance Test Setup

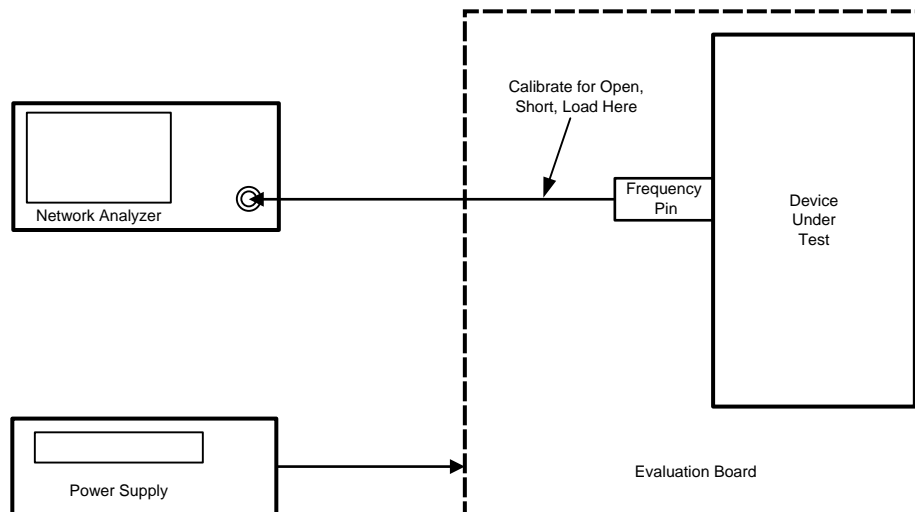

A network analyzer can be used to measure the input impedance of the OSCin and ExtVCOin pin as well as the output impedance of the RFout pin. The general technique is to connect the desired pin with no DC blocking capacitor to a network analyzer and measure the impedance directly. The part needs to be programmed to ensure that it is in a known state. There are some special considerations that should be taken for different measurements of the three different impedances.

#### 10.1.4.1 OSCin Input Impedance Measurement

For this pin, the provided calibration standards are typically good enough for a decent measurement. A single-ended measurement at the OSCin or OSCin\* pins can be made. For a differential measurement, this needs to be treated by the instrument as a two port network.

#### 10.1.4.2 ExtVCOin Input Impedance Measurement

Because this pin goes higher in frequency, it is often difficult to get a good measurement at higher frequencies because of the effects of the board and SMA connector. One technique that can be used is instead of using the provided calibration standards that come with the equipment, solder resistors directly to the board in order to calibrate out the effects of the board as well. A 0 ohm resistor functions as a short, no resistor functions as an open, and two parallel 100 ohm resistors serve as a load. These should be soldered as close to the part as possible. Once this calibration is done, the measurement can be done as normal.

#### 10.1.4.3 RFout Output Impedance Measurement

Although output and input impedance are not the same thing, they can be measured in a similar way. Because this pin is a higher frequency, it is better to use the same method for calibration as used for the ExtVCOin pin. The other consideration for the RFout pin is that there are many different settings that impact this input impedance. When in bypass mode (VCO\_DIV=1), the VCOGAIN and OUTTERM words can change the impedance. When in divided mode (VCO\_DIV>1), the DIVGAIN and OUTTERM words can impact the impedance.

### 10.1.5 ExtVCOin (NOT OSCin) Input Sensitivity Test Setup

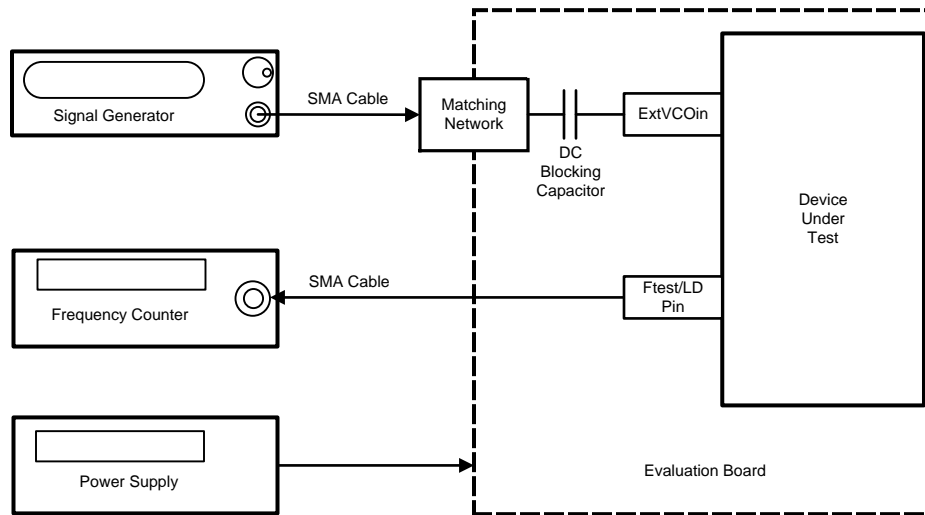

In order to measure the ExtVCOin Input sensitivity, the part is put in External VCO mode and a signal is applied to the ExtVCOin pin. A matching network, which is typically a 3 dB pad, is used and this loss is added to the measured numbers as well as any potential cable losses (on the order of 1 dB). A signal is applied at a known frequency and power and the output of the N counter is monitored using the Ftest/LD pin and setting it to look at the N counter output divided by 2. Typically, the divide by 2 function is better because if it is not used, the duty cycle from the Ftest/LD pin is not 50% and this can sometimes confuse frequency counters. The part is set in fractional mode with a large fraction of  $502 + 2097150/4194301$  to ensure that the fractional circuitry gets fully tested. Accounting for the extra divide by 2 from the Ftest/LD pin, the divided output frequency should be the input frequency divided by 1005 to a 1 ppm tolerance.

### 10.1.6 OSCin Input Sensitivity Test Setup

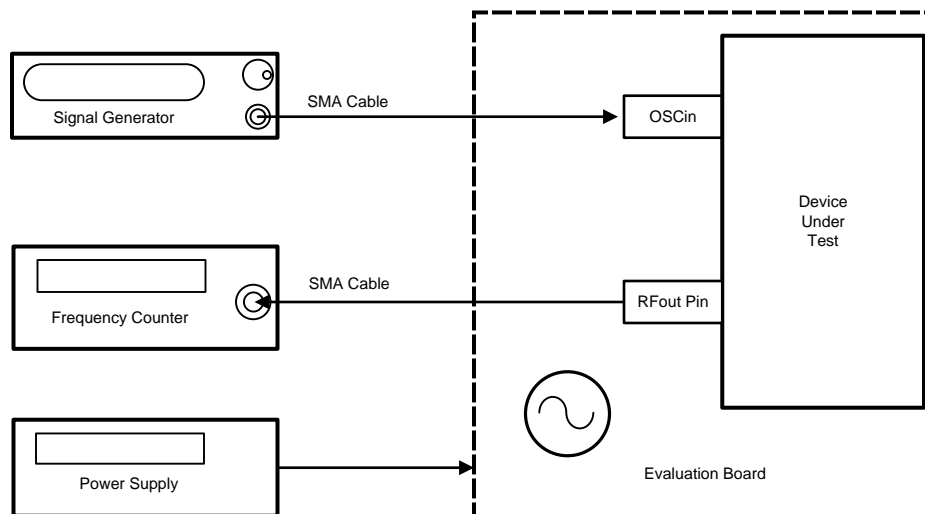

#### 10.1.6.1 Input Sensitivity Test Procedure

There are two things that are important to consider when measuring the OSCin sensitivity.

- The action of setting the Ftest/LD pin to monitor the R divider output degrades the OSCin sensitivity.
- The internal VCO frequency calibration is based on the OSCin signal

Because of these considerations, the OSCin sensitivity needs to be measured in a closed loop test in such a way that the internal frequency calibration is not distorting the measurement. To do this, a known frequency and power level are set at the OSCin pin and the power level is changed until the PLL becomes more than 1 ppm off frequency. The PLL\_R divider is varied to maintain a phase detector frequency of 1 MHz to ensure that the PLL loop does not become unstable. The frequency counter needs to be synchronized in frequency to the signal generator. It is better to use a narrower loop bandwidth for this test because the phase noise of the PLL might degrade when the OSCin power level gets to close to the sensitivity limits. Typically, a 0.1  $\mu\text{F}$  capacitor is used as a DC block for the signal at the OSCin pin. The sensitivity at the OSCin pin is measured with a single-ended input.

This test can be run in internal VCO mode (MODE=0) or external VCO mode (MODE=1). When doing the test in internal VCO mode, the part needs to be initially locked and then the R counter is programmed to adjust for the OSCin frequency. However, in internal VCO mode, the PLL\_N counter cannot be programmed, because the action of programming this counter activates the internal VCO frequency calibration, which can interfere with the test.

### 10.1.6.2 OSCin Slew Rate Tests

There are two methods that can be used to test the OSCin slew rate. One method is to use test equipment that actually allows the user to vary the slew rate directly, but this type of equipment typically does not give the user enough range of adjustability. Another method is to calculate the slew rate based on the slope of a sine wave of known frequency and amplitude. For this method, the slew rate can be calculated from the frequency and peak to peak amplitude of the OSCin signal as follows:  $\text{Slew}_{\text{OSCin}} = 2 \times \pi \times f_{\text{OSCin}} \times V_{\text{ppOSCin}}$

### 10.1.7 Typical Connections

**Figure 32. Full Chip Mode, Differential OSCin**

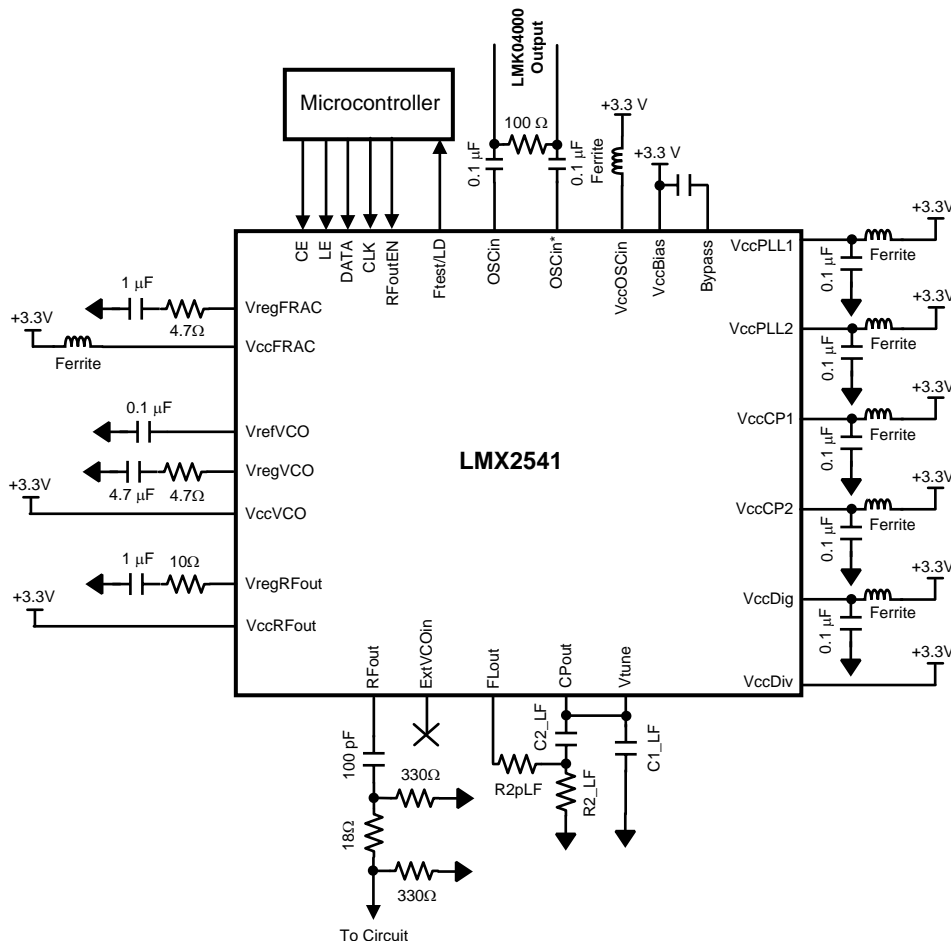
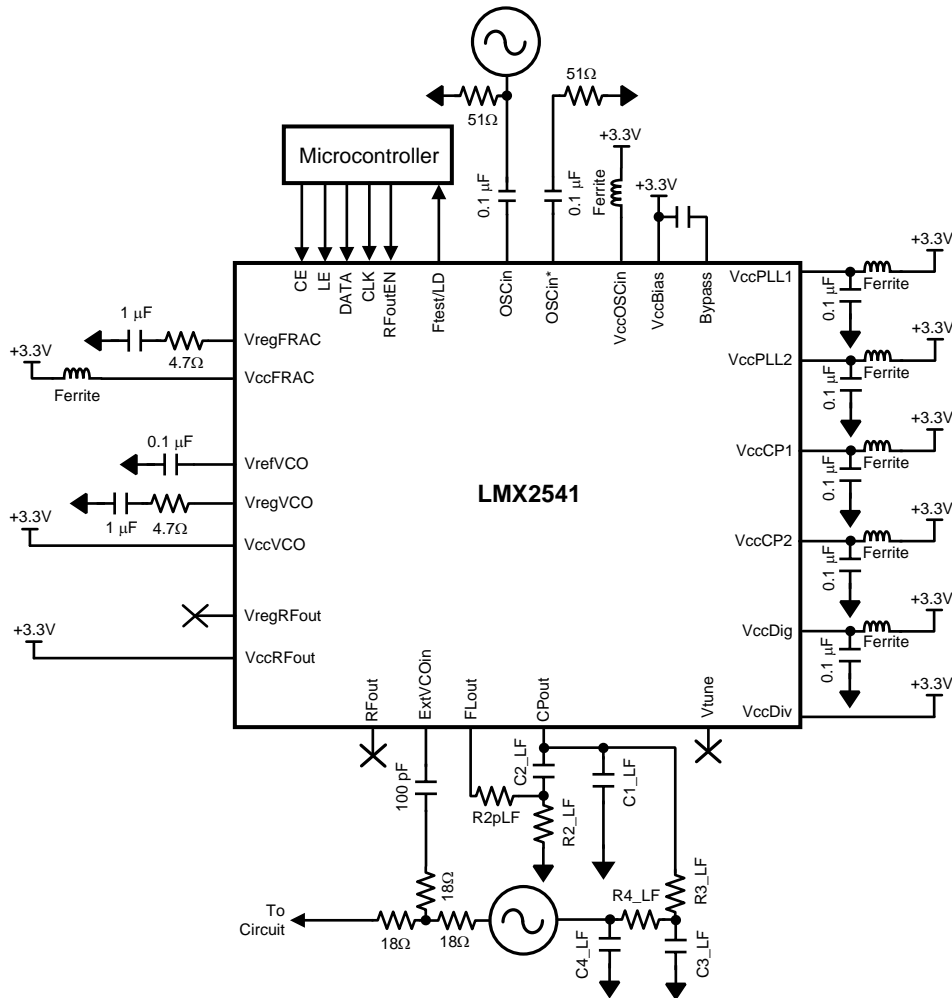

Figure 33. External VCO Mode, Single-Ended OSCin, RFout Pin not Used



For both of the able connection diagrams, L1, L2, and Lmid should be left open, but the pads should be placed on these pins for optimal solderability. The GND pins should have separate vias to ground and the GND DAP also needs to be grounded with 9 vias. The VccVCO, VccRFout, and VccDiv pins can be shorted to the power plane, but need to be connected. For the other Vcc pins, ferrite beads and bypass capacitors may be added in order to improve spurious performance. VregVCO and VrefVCO need to be connected even if the internal VCO is not being used. The VregRFout pin only needs to be connected if the RFout pin is being used. When a block is not used, it is always still necessary to connect the corresponding Vcc pin, but the bypassing is not necessary, as shown in the above diagram for the external VCO mode.

#### 10.1.7.1 OSCin/OSCin\* Connections

For single-ended operation, the signal is driven into the OSCin pin. The OSCin\* pin is terminated the same as the OSCin pin. This is a typical case if the device is driven by a TCXO. For both single-ended and differential operation, the input is AC coupled because the OSCin/OSCin\* pins self-bias to an optimal DC operating point. Better performance for both phase noise and fractional spurs is obtained for signals with a higher slew rate, such as a square wave. This is especially important for lower frequency signals, because slower frequency sine waves have lower slew rates. Fractional spurs are typically about four dB better when running in differential mode as opposed to single-ended mode.

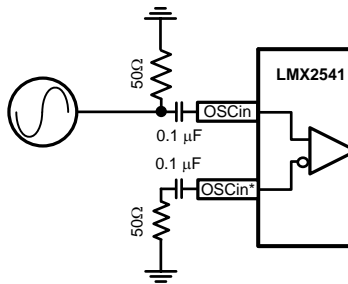
**Figure 34. Single-Ended Operation**

For differential operation, as is the case when using an LVDS or LVPECL driver, a 100 Ω resistor is placed across the OSCin/OSCin\* traces

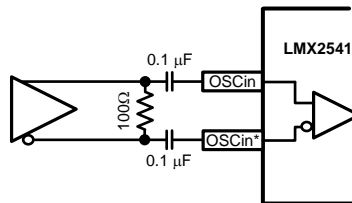
**Figure 35. Differential Operation**

A third way to configure the device is in crystal mode ( $XO = 1$ ). For this, the crystal is placed across the OSCin/OSCin\* pins. Crystals are specified for a specific load capacitance,  $C_{Load}$ . The load capacitors shown in the figure each have a value of  $C_{Load}/2$ .

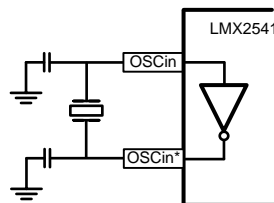
**Figure 36. Crystal Mode Operation**

## 10.2 Typical Application

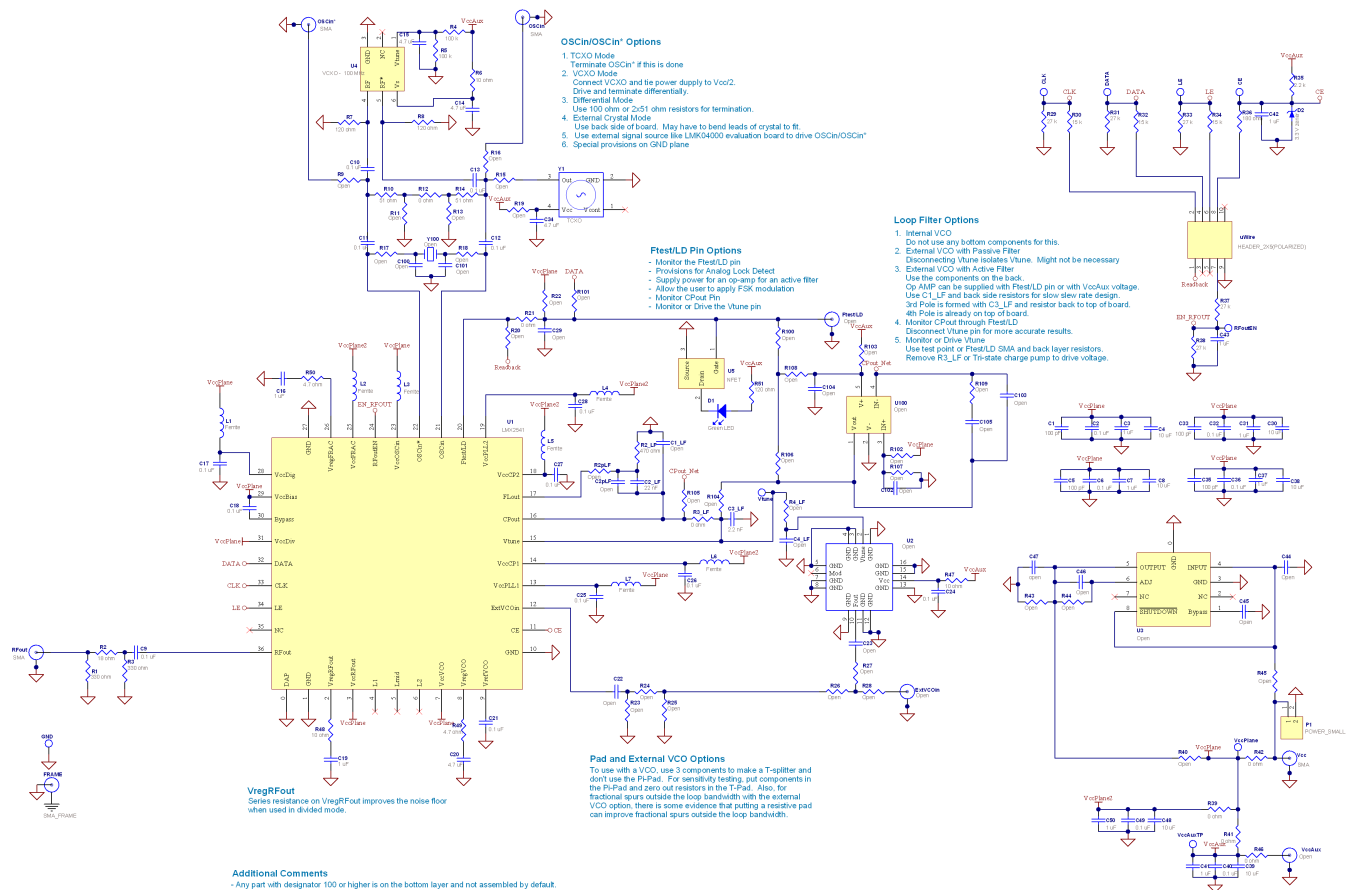

### 10.2.1 Design Requirements

Consider generating 4000.25 MHz from a 100-MHz XO input frequency.

For this design example, use the parameters listed in [Table 19](#) as the user-input parameters.

**Table 19. Design Parameters**

PARAMETER	VALUE	REASON FOR CHOOSING
Fout	4000.25 MHz	This parameter was given.
Fosc	100 MHz	This parameter was given.
Fpd	25 MHz	Although the phase detector could be chosen to be 100 MHz, it is being chosen lower to reduce the integer boundary spur at 250 kHz offset.
Loop Bandwidth	53 kHz	A wider bandwidth gives better in-band phase noise, but then the integer boundary spur is higher. This gives a reasonable trade-off.
Kpd	3.2 mA	Maximum charge pump gain is best for the lowest PLL phase noise.
C1_LF	2.2 nF	The external loop filter components can be found using design software from TI.
C2_LF	22 nF	
R2_LF	470 Ω	
C3_LF	20 pF	
C4_LF	100 pF	The internal loop filter was chosen with the resistors to a lower setting to allow a wider bandwidth. However, it is best to put the most capacitance on C4 as it gives more filtering.
R3_LF	1 kΩ	
R4_LF	200 Ω	

### 10.2.2 Detailed Design Procedure

Use the WEBENCH® [Clock Architect](#) to calculate the values of C2\_LF and R2\_LF.

Use C4 for the largest capacitance because it offers more filtering.

### 10.2.3 Application Curves

For [Figure 38](#) and [Figure 39](#), a third order modulator with dithering disabled was used with a fractional denominator of 500000. The charge pump gain was 32X and the loop filter components were C1 = 2.2 nF, C2 = 22 nF, R2 = 470 Ω. The internal loop filter components were C3\_LF = 20 pF, C4\_LF = 100 pF, R3\_LF = 1 kΩ, R4\_LF = 200 Ω.

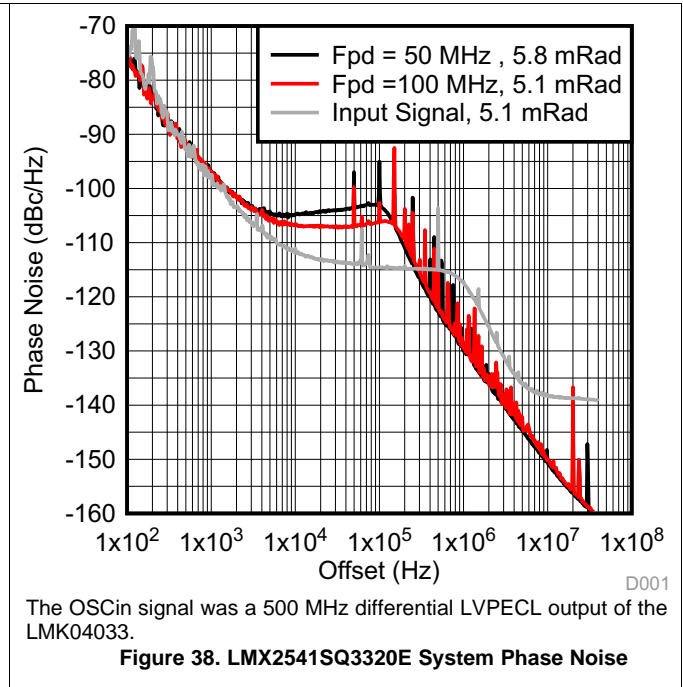
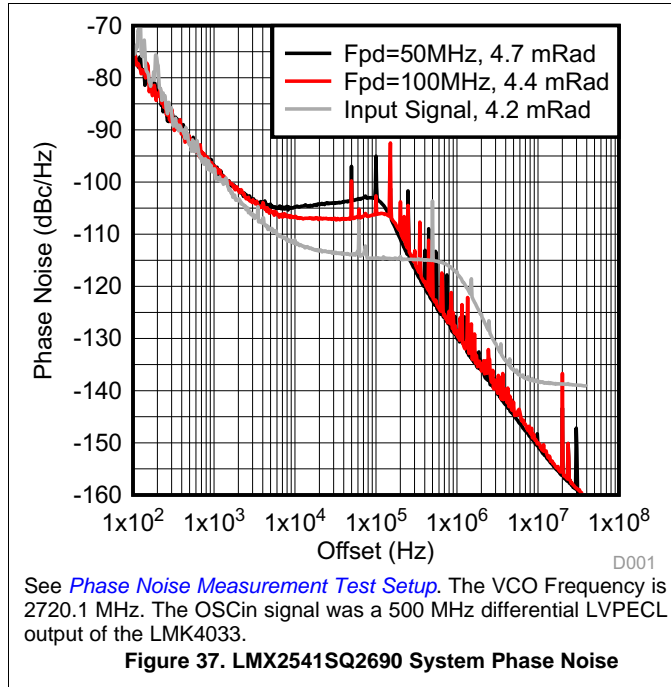

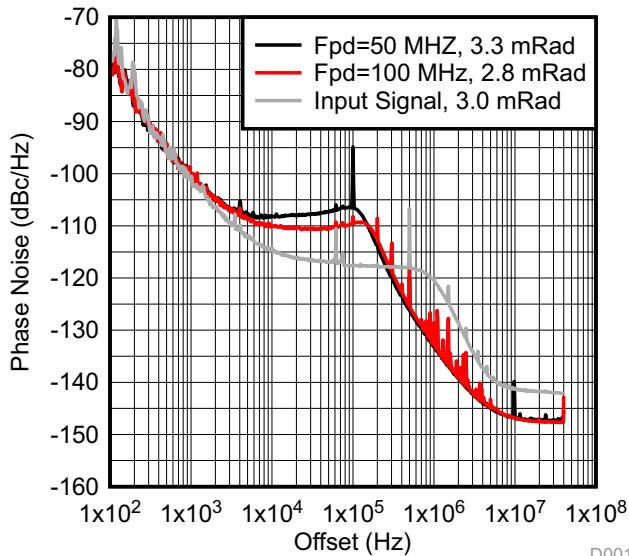

The OSCin signal was a 500 MHz differential LVPECL output of the LMK04033.

Figure 39. LMX2541SQ3740E System Phase Noise

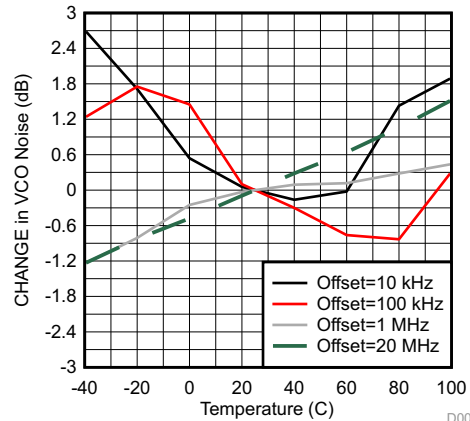

The above plot shows how much the VCO phase noise typically change over temperature relative to room temperature. The typical values for represent an average over all frequencies and part options and therefore there are some small variations over part options and frequencies that are not shown. VCO phase noise numbers room temperature are reported in the electrical specifications. A negative value indicates a phase noise improvement.

Figure 40. VCO Phase Noise Degradation vs. Temperature and Offset  
(VCO Relocked at Each Temperature Vcc = 3.3 V, AC\_TEMP\_COMP = 5)

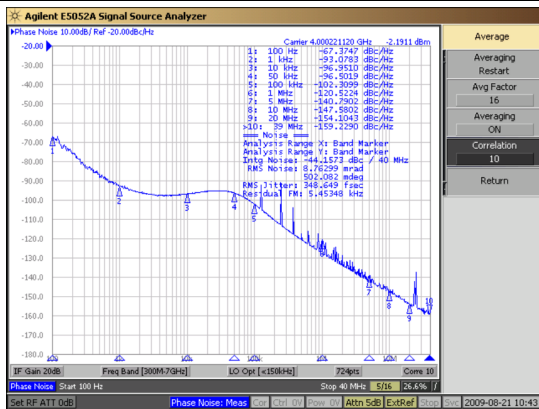

Figure 41. Phase Noise at 4000.25 MHz

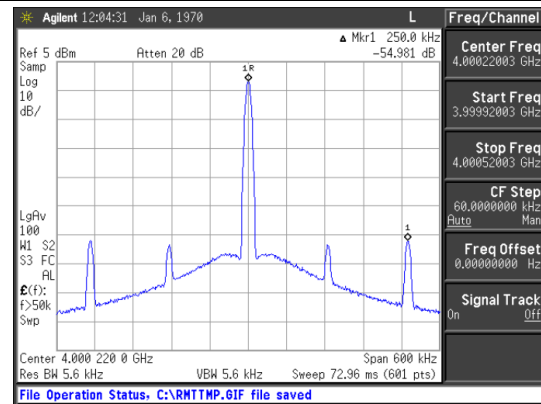

Figure 42. Integer Boundary Spur Measurement

## 11 Power Supply Recommendations

The LMX2541 has an internal low-noise regulator for the internal VCO, which makes it more immune to supply noise than many devices with an integrated VCO. That being said, the VCO is extremely sensitive to noise so it is recommended to use an LDO or clean power supply for this device; a switching power supply would likely generate unwanted spurs on the output.

## 12 Layout

### 12.1 Layout Guidelines

#### 12.1.1 Configuring the LMX2541 for Optimal Performance

1. Determine the Channel Spacing ( $f_{CH}$ )
  - For a system that has a VCO that tunes over several frequencies, the channel spacing is the tuning increment. In the case that the VCO frequency is fixed, this channel spacing is the greatest number that divides both the VCO frequency and the OSCin frequency.
2. Determine OSCin Frequency ( $f_{OSCin}$ )
  - If the OSCin frequency is not already determined, then there are several considerations. A higher frequency is generally, but not always, preferable. One reason for this is that it has a higher slew rate if it is a sine wave. Another reason is that the clock for the VCO frequency calibration is based on the OSCin frequency and in general will run faster for higher OSCin frequencies.
  - Although a higher OSCin frequency is desirable, there are also reasons to use a lower frequency. If the OSCin frequency is strategically chosen, the worst case fractional spur channels might fall out of band. Also, if the OSCin frequency can be chosen such that the fractional denominator can avoid factors of 2 and/or 3, the sub-fractional spurs can be reduced.
3. Determine the Phase Detector Frequency ( $f_{PD}$ ), Charge Pump Gain ( $K_{PD}$ ) and Fractional Denominator (FDEN)
  - In general, choose the highest phase detector frequency and charge pump gain, unless it leads to loop filter capacitor values that are unrealistically large for a given loop bandwidth. In this case, reducing either the phase detector frequency or the charge pump gain can yield more feasible capacitor values. Other reasons for not using the highest charge pump gain is to allow some adjustment margin to compensate for changes in the VCO gain or allow the use of Fastlock.
  - For choosing the fractional denominator, start with  $FDEN = f_{PD}/f_{CH}$ . As discussed previously, there might be reasons to choose larger equivalent fractions.
4. Design the Loop Filter
5. Determine the Modulator Order
6. Determine Dithering and Potential Larger Equivalent Fractional Value



## 13 Device and Documentation Support

### 13.1 Device Support

For the Clock Architect tool, go to <http://www.ti.com/lstds/ti/analog/webench/clock-architect.page>

### 13.2 Trademarks

All trademarks are the property of their respective owners.

### 13.3 Electrostatic Discharge Caution



These devices have limited built-in ESD protection. The leads should be shorted together or the device placed in conductive foam during storage or handling to prevent electrostatic damage to the MOS gates.

### 13.4 Glossary

[SLYZ022](#) — *TI Glossary*.

This glossary lists and explains terms, acronyms, and definitions.

## 14 Mechanical, Packaging, and Orderable Information

The following pages include mechanical, packaging, and orderable information. This information is the most current data available for the designated devices. This data is subject to change without notice and revision of this document. For browser-based versions of this data sheet, refer to the left-hand navigation.

**PACKAGING INFORMATION**

Orderable Device	Status (1)	Package Type	Package Drawing	Pins	Package Qty	Eco Plan (2)	Lead/Ball Finish (6)	MSL Peak Temp (3)	Op Temp (°C)	Device Marking (4/5)	Samples
LMX2541SQ2060E/NOPB	ACTIVE	WQFN	NJK	36	1000	Green (RoHS & no Sb/Br)	CU SN	Level-3-260C-168 HR	-40 to 85	412060E	<a href="#">Samples</a>
LMX2541SQ2380E/NOPB	ACTIVE	WQFN	NJK	36	1000	Green (RoHS & no Sb/Br)	CU SN	Level-3-260C-168 HR	-40 to 85	412380E	<a href="#">Samples</a>
LMX2541SQ2690E/NOPB	ACTIVE	WQFN	NJK	36	1000	Green (RoHS & no Sb/Br)	CU SN	Level-3-260C-168 HR	-40 to 85	412690E	<a href="#">Samples</a>
LMX2541SQ3030E/NOPB	ACTIVE	WQFN	NJK	36	1000	Green (RoHS & no Sb/Br)	CU SN	Level-3-260C-168 HR	-40 to 85	413030E	<a href="#">Samples</a>
LMX2541SQ3320E/NOPB	ACTIVE	WQFN	NJK	36	1000	Green (RoHS & no Sb/Br)	CU SN	Level-3-260C-168 HR	-40 to 85	413320E	<a href="#">Samples</a>
LMX2541SQ3740E/NOPB	ACTIVE	WQFN	NJK	36	1000	Green (RoHS & no Sb/Br)	CU SN	Level-3-260C-168 HR	-40 to 85	413740E	<a href="#">Samples</a>
LMX2541SQE2060E/NOPB	ACTIVE	WQFN	NJK	36	250	Green (RoHS & no Sb/Br)	CU SN	Level-3-260C-168 HR	-40 to 85	412060E	<a href="#">Samples</a>
LMX2541SQE2380E/NOPB	ACTIVE	WQFN	NJK	36	250	Green (RoHS & no Sb/Br)	CU SN	Level-3-260C-168 HR	-40 to 85	412380E	<a href="#">Samples</a>
LMX2541SQE2690E/NOPB	ACTIVE	WQFN	NJK	36	250	Green (RoHS & no Sb/Br)	CU SN	Level-3-260C-168 HR	-40 to 85	412690E	<a href="#">Samples</a>
LMX2541SQE3030E/NOPB	ACTIVE	WQFN	NJK	36	250	Green (RoHS & no Sb/Br)	CU SN	Level-3-260C-168 HR	-40 to 85	413030E	<a href="#">Samples</a>
LMX2541SQE3320E/NOPB	ACTIVE	WQFN	NJK	36	250	Green (RoHS & no Sb/Br)	CU SN	Level-3-260C-168 HR	-40 to 85	413320E	<a href="#">Samples</a>
LMX2541SQE3740E/NOPB	ACTIVE	WQFN	NJK	36	250	Green (RoHS & no Sb/Br)	CU SN	Level-3-260C-168 HR	-40 to 85	413740E	<a href="#">Samples</a>

(1) The marketing status values are defined as follows:

**ACTIVE:** Product device recommended for new designs.

**LIFEBUY:** TI has announced that the device will be discontinued, and a lifetime-buy period is in effect.

**NRND:** Not recommended for new designs. Device is in production to support existing customers, but TI does not recommend using this part in a new design.

**PREVIEW:** Device has been announced but is not in production. Samples may or may not be available.

**OBSELETE:** TI has discontinued the production of the device.

(2) Eco Plan - The planned eco-friendly classification: Pb-Free (RoHS), Pb-Free (RoHS Exempt), or Green (RoHS & no Sb/Br) - please check <http://www.ti.com/productcontent> for the latest availability information and additional product content details.

**TBD:** The Pb-Free/Green conversion plan has not been defined.

---

**Pb-Free (RoHS):** TI's terms "Lead-Free" or "Pb-Free" mean semiconductor products that are compatible with the current RoHS requirements for all 6 substances, including the requirement that lead not exceed 0.1% by weight in homogeneous materials. Where designed to be soldered at high temperatures, TI Pb-Free products are suitable for use in specified lead-free processes.

**Pb-Free (RoHS Exempt):** This component has a RoHS exemption for either 1) lead-based flip-chip solder bumps used between the die and package, or 2) lead-based die adhesive used between the die and leadframe. The component is otherwise considered Pb-Free (RoHS compatible) as defined above.

**Green (RoHS & no Sb/Br):** TI defines "Green" to mean Pb-Free (RoHS compatible), and free of Bromine (Br) and Antimony (Sb) based flame retardants (Br or Sb do not exceed 0.1% by weight in homogeneous material)

<sup>(3)</sup> MSL, Peak Temp. - The Moisture Sensitivity Level rating according to the JEDEC industry standard classifications, and peak solder temperature.

<sup>(4)</sup> There may be additional marking, which relates to the logo, the lot trace code information, or the environmental category on the device.

<sup>(5)</sup> Multiple Device Markings will be inside parentheses. Only one Device Marking contained in parentheses and separated by a "~" will appear on a device. If a line is indented then it is a continuation of the previous line and the two combined represent the entire Device Marking for that device.

<sup>(6)</sup> Lead/Ball Finish - Orderable Devices may have multiple material finish options. Finish options are separated by a vertical ruled line. Lead/Ball Finish values may wrap to two lines if the finish value exceeds the maximum column width.

**Important Information and Disclaimer:**The information provided on this page represents TI's knowledge and belief as of the date that it is provided. TI bases its knowledge and belief on information provided by third parties, and makes no representation or warranty as to the accuracy of such information. Efforts are underway to better integrate information from third parties. TI has taken and continues to take reasonable steps to provide representative and accurate information but may not have conducted destructive testing or chemical analysis on incoming materials and chemicals. TI and TI suppliers consider certain information to be proprietary, and thus CAS numbers and other limited information may not be available for release.

In no event shall TI's liability arising out of such information exceed the total purchase price of the TI part(s) at issue in this document sold by TI to Customer on an annual basis.

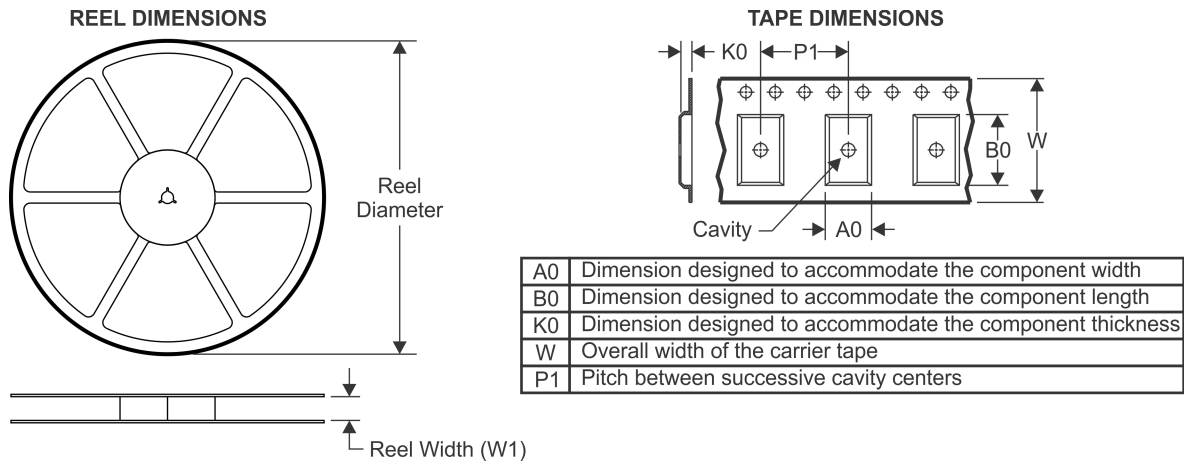
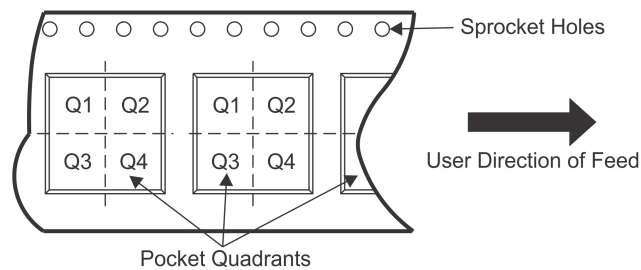
**TAPE AND REEL INFORMATION**

**QUADRANT ASSIGNMENTS FOR PIN 1 ORIENTATION IN TAPE**

\*All dimensions are nominal

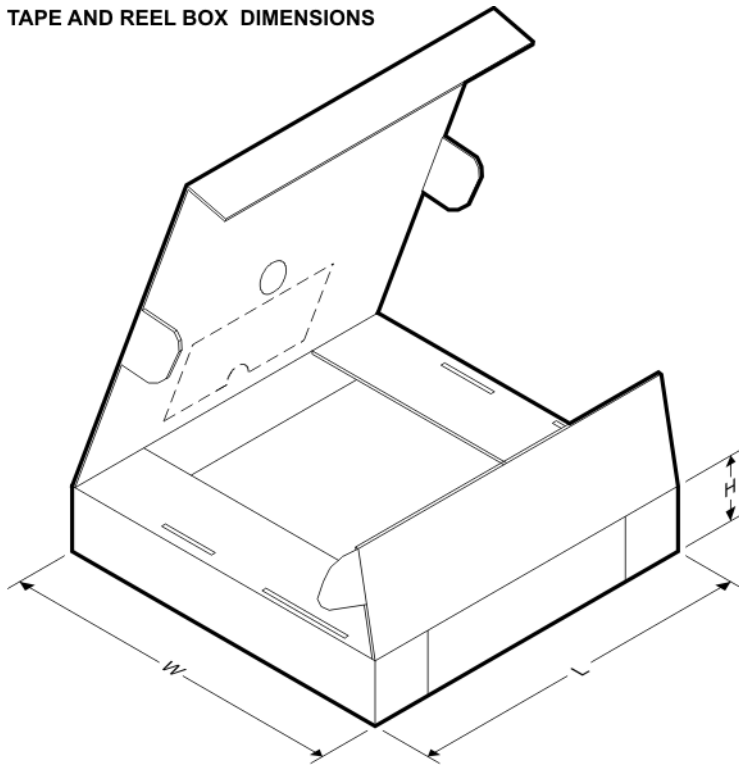
Device	Package Type	Package Drawing	Pins	SPQ	Reel Diameter (mm)	Reel Width W1 (mm)	A0 (mm)	B0 (mm)	K0 (mm)	P1 (mm)	W (mm)	Pin1 Quadrant
LMX2541SQ2060E/NOPB	WQFN	NJK	36	1000	330.0	16.4	6.3	6.3	1.5	12.0	16.0	Q1
LMX2541SQ2380E/NOPB	WQFN	NJK	36	1000	330.0	16.4	6.3	6.3	1.5	12.0	16.0	Q1
LMX2541SQ2690E/NOPB	WQFN	NJK	36	1000	330.0	16.4	6.3	6.3	1.5	12.0	16.0	Q1
LMX2541SQ3030E/NOPB	WQFN	NJK	36	1000	330.0	16.4	6.3	6.3	1.5	12.0	16.0	Q1
LMX2541SQ3320E/NOPB	WQFN	NJK	36	1000	330.0	16.4	6.3	6.3	1.5	12.0	16.0	Q1
LMX2541SQ3740E/NOPB	WQFN	NJK	36	1000	330.0	16.4	6.3	6.3	1.5	12.0	16.0	Q1
LMX2541SQE2060E/NOPB	WQFN	NJK	36	250	178.0	16.4	6.3	6.3	1.5	12.0	16.0	Q1
LMX2541SQE2380E/NOPB	WQFN	NJK	36	250	178.0	16.4	6.3	6.3	1.5	12.0	16.0	Q1
LMX2541SQE2690E/NOPB	WQFN	NJK	36	250	178.0	16.4	6.3	6.3	1.5	12.0	16.0	Q1
LMX2541SQE3030E/NOPB	WQFN	NJK	36	250	178.0	16.4	6.3	6.3	1.5	12.0	16.0	Q1
LMX2541SQE3320E/NOPB	WQFN	NJK	36	250	178.0	16.4	6.3	6.3	1.5	12.0	16.0	Q1
LMX2541SQE3740E/NOPB	WQFN	NJK	36	250	178.0	16.4	6.3	6.3	1.5	12.0	16.0	Q1

**TAPE AND REEL BOX DIMENSIONS**

\*All dimensions are nominal

Device	Package Type	Package Drawing	Pins	SPQ	Length (mm)	Width (mm)	Height (mm)
LMX2541SQ2060E/NOPB	WQFN	NJK	36	1000	367.0	367.0	38.0
LMX2541SQ2380E/NOPB	WQFN	NJK	36	1000	367.0	367.0	38.0
LMX2541SQ2690E/NOPB	WQFN	NJK	36	1000	367.0	367.0	38.0
LMX2541SQ3030E/NOPB	WQFN	NJK	36	1000	367.0	367.0	38.0
LMX2541SQ3320E/NOPB	WQFN	NJK	36	1000	367.0	367.0	38.0
LMX2541SQ3740E/NOPB	WQFN	NJK	36	1000	367.0	367.0	38.0
LMX2541SQE2060E/NOP B	WQFN	NJK	36	250	210.0	185.0	35.0
LMX2541SQE2380E/NOP B	WQFN	NJK	36	250	210.0	185.0	35.0
LMX2541SQE2690E/NOP B	WQFN	NJK	36	250	210.0	185.0	35.0
LMX2541SQE3030E/NOP B	WQFN	NJK	36	250	210.0	185.0	35.0
LMX2541SQE3320E/NOP B	WQFN	NJK	36	250	210.0	185.0	35.0
LMX2541SQE3740E/NOP B	WQFN	NJK	36	250	210.0	185.0	35.0

NJK0036A

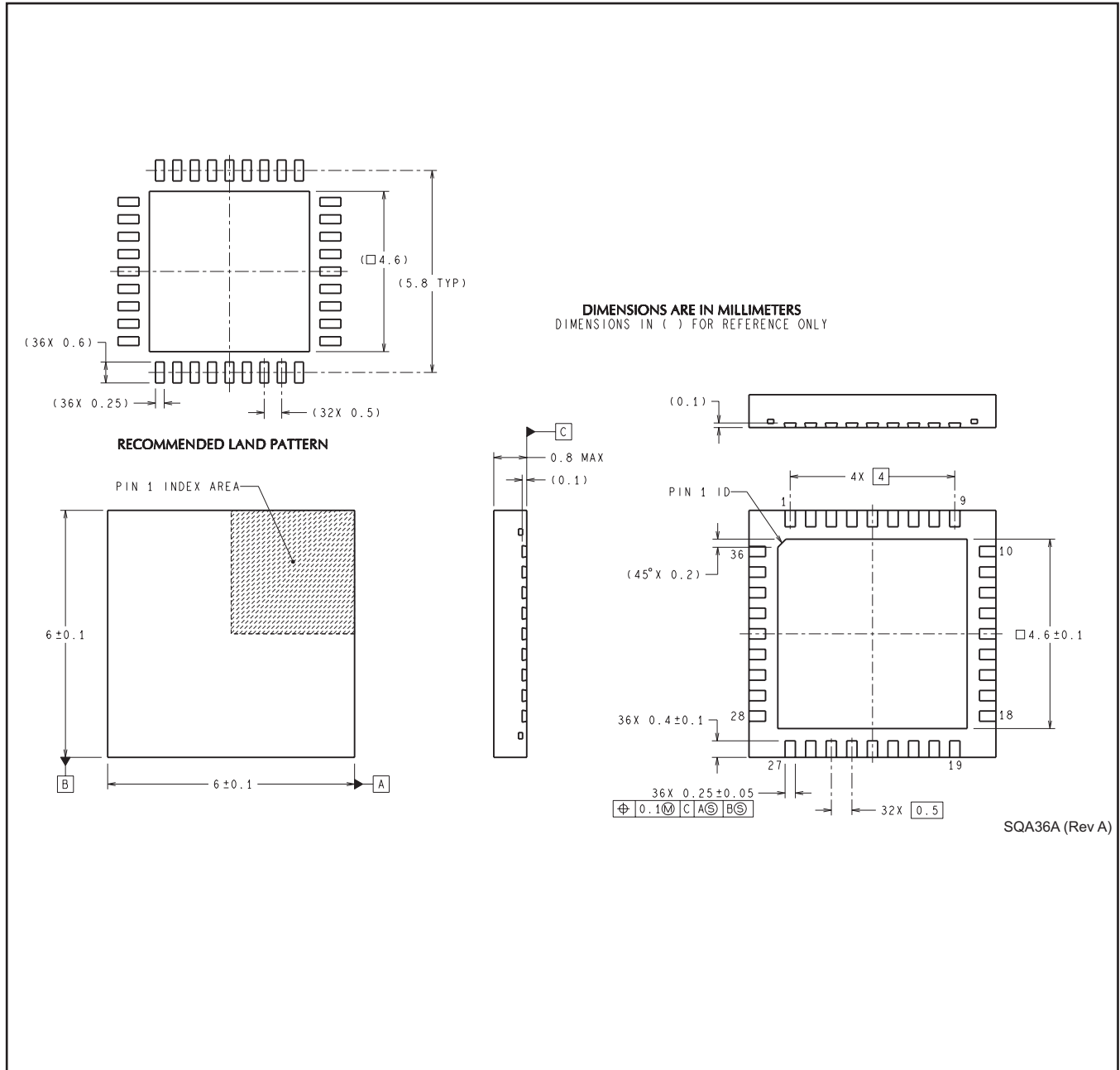

## IMPORTANT NOTICE

Texas Instruments Incorporated and its subsidiaries (TI) reserve the right to make corrections, enhancements, improvements and other changes to its semiconductor products and services per JESD46, latest issue, and to discontinue any product or service per JESD48, latest issue. Buyers should obtain the latest relevant information before placing orders and should verify that such information is current and complete. All semiconductor products (also referred to herein as "components") are sold subject to TI's terms and conditions of sale supplied at the time of order acknowledgment.

TI warrants performance of its components to the specifications applicable at the time of sale, in accordance with the warranty in TI's terms and conditions of sale of semiconductor products. Testing and other quality control techniques are used to the extent TI deems necessary to support this warranty. Except where mandated by applicable law, testing of all parameters of each component is not necessarily performed.

TI assumes no liability for applications assistance or the design of Buyers' products. Buyers are responsible for their products and applications using TI components. To minimize the risks associated with Buyers' products and applications, Buyers should provide adequate design and operating safeguards.

TI does not warrant or represent that any license, either express or implied, is granted under any patent right, copyright, mask work right, or other intellectual property right relating to any combination, machine, or process in which TI components or services are used. Information published by TI regarding third-party products or services does not constitute a license to use such products or services or a warranty or endorsement thereof. Use of such information may require a license from a third party under the patents or other intellectual property of the third party, or a license from TI under the patents or other intellectual property of TI.

Reproduction of significant portions of TI information in TI data books or data sheets is permissible only if reproduction is without alteration and is accompanied by all associated warranties, conditions, limitations, and notices. TI is not responsible or liable for such altered documentation. Information of third parties may be subject to additional restrictions.

Resale of TI components or services with statements different from or beyond the parameters stated by TI for that component or service voids all express and any implied warranties for the associated TI component or service and is an unfair and deceptive business practice. TI is not responsible or liable for any such statements.

Buyer acknowledges and agrees that it is solely responsible for compliance with all legal, regulatory and safety-related requirements concerning its products, and any use of TI components in its applications, notwithstanding any applications-related information or support that may be provided by TI. Buyer represents and agrees that it has all the necessary expertise to create and implement safeguards which anticipate dangerous consequences of failures, monitor failures and their consequences, lessen the likelihood of failures that might cause harm and take appropriate remedial actions. Buyer will fully indemnify TI and its representatives against any damages arising out of the use of any TI components in safety-critical applications.

In some cases, TI components may be promoted specifically to facilitate safety-related applications. With such components, TI's goal is to help enable customers to design and create their own end-product solutions that meet applicable functional safety standards and requirements. Nonetheless, such components are subject to these terms.

No TI components are authorized for use in FDA Class III (or similar life-critical medical equipment) unless authorized officers of the parties have executed a special agreement specifically governing such use.

Only those TI components which TI has specifically designated as military grade or "enhanced plastic" are designed and intended for use in military/aerospace applications or environments. Buyer acknowledges and agrees that any military or aerospace use of TI components which have **not** been so designated is solely at the Buyer's risk, and that Buyer is solely responsible for compliance with all legal and regulatory requirements in connection with such use.

TI has specifically designated certain components as meeting ISO/TS16949 requirements, mainly for automotive use. In any case of use of non-designated products, TI will not be responsible for any failure to meet ISO/TS16949.

### Products

Audio	<a href="http://www.ti.com/audio">www.ti.com/audio</a>
Amplifiers	<a href="http://amplifier.ti.com">amplifier.ti.com</a>
Data Converters	<a href="http://dataconverter.ti.com">dataconverter.ti.com</a>
DLP® Products	<a href="http://www.dlp.com">www.dlp.com</a>
DSP	<a href="http://dsp.ti.com">dsp.ti.com</a>
Clocks and Timers	<a href="http://www.ti.com/clocks">www.ti.com/clocks</a>
Interface	<a href="http://interface.ti.com">interface.ti.com</a>
Logic	<a href="http://logic.ti.com">logic.ti.com</a>
Power Mgmt	<a href="http://power.ti.com">power.ti.com</a>
Microcontrollers	<a href="http://microcontroller.ti.com">microcontroller.ti.com</a>
RFID	<a href="http://www.ti-rfid.com">www.ti-rfid.com</a>
OMAP Applications Processors	<a href="http://www.ti.com/omap">www.ti.com/omap</a>
Wireless Connectivity	<a href="http://www.ti.com/wirelessconnectivity">www.ti.com/wirelessconnectivity</a>

### Applications

Automotive and Transportation	<a href="http://www.ti.com/automotive">www.ti.com/automotive</a>
Communications and Telecom	<a href="http://www.ti.com/communications">www.ti.com/communications</a>
Computers and Peripherals	<a href="http://www.ti.com/computers">www.ti.com/computers</a>
Consumer Electronics	<a href="http://www.ti.com/consumer-apps">www.ti.com/consumer-apps</a>
Energy and Lighting	<a href="http://www.ti.com/energy">www.ti.com/energy</a>
Industrial	<a href="http://www.ti.com/industrial">www.ti.com/industrial</a>
Medical	<a href="http://www.ti.com/medical">www.ti.com/medical</a>
Security	<a href="http://www.ti.com/security">www.ti.com/security</a>
Space, Avionics and Defense	<a href="http://www.ti.com/space-avionics-defense">www.ti.com/space-avionics-defense</a>
Video and Imaging	<a href="http://www.ti.com/video">www.ti.com/video</a>

### TI E2E Community

[e2e.ti.com](http://e2e.ti.com)

## Looking for pricing, stock, or lifecycle information?

Click below to explore more details on WIN SOURCE:

 [View LMX2541SQE2690E/NOPB on WIN SOURCE](#)

 [Texas Instruments](#) Information

## Optimize Your Supply Chain with WIN SOURCE Solutions

-  Global Sourcing Solution
-  Obsolete Management
-  Cost Control Management
-  Shortage Management
-  Alternative Solution
-  Excess Inventory Management