



**THE DATASHEET OF
LMZ10505TZ-ADJ/NOPB**



LMZ10505 5-A Power Module With 5.5-V Maximum Input Voltage

1 Features

- Integrated Shielded Inductor
- Flexible Start-up Sequencing Using External Soft-Start, Tracking, and Precision Enable
- Protection Against In-Rush Currents and Faults such as Input UVLO and Output Short-Circuit
- Single Exposed Pad and Standard Pinout for Easy Mounting and Manufacturing
- Pin-to-Pin Compatible With
 - LMZ10503 (3-A/15-W Maximum)
 - LMZ10504 (4-A/20-W Maximum)
- Fully Enable for WEBENCH® and Power Designer
- Electrical Specifications
 - 25-W Maximum Total Output Power
 - Up to 5-A Output Current
 - Input Voltage Range 2.95 V to 5.5 V
 - Output Voltage Range 0.8 V to 5 V
 - $\pm 1.63\%$ Feedback Voltage Accuracy Over Temperature
 - Efficiency up to 96%
- Performance Benefits
 - Operates at High Ambient Temperatures
 - High Efficiency up to 96% Reduces System Heat Generation
 - Low Radiated Emissions (EMI) Tested to EN55022 Class B Standard (EN 55022:2006, +A1:2007, FCC Part 15 Subpart B: 2007. See [Table 9](#) and Layout for Information on Device Under Test.)
 - Passes 10-V/m Radiated Immunity EMI Tested to Standard EN61000 4-3
 - Fast Transient Response for Powering FPGAs and ASICs
- Create a Custom Design Using the LMZ10505 With the [WEBENCH® Power Designer](#)

2 Applications

- Point-of-Load Conversions from 3.3-V and 5-V Rails
- Space-Constrained Applications
- Noise-Sensitive Applications (Such as Transceiver, Medical)

3 Description

The LMZ10505 power module is a complete, easy-to-use, DC-DC solution capable of driving up to a 5-A load with exceptional power conversion efficiency, output voltage accuracy, line and load regulation. The LMZ10505 is available in an innovative package that enhances thermal performance and allows for hand or machine soldering.

The LMZ10505 can accept an input voltage rail between 2.95 V and 5.5 V and can deliver an adjustable and highly accurate output voltage as low as 0.8 V. One megahertz fixed-frequency PWM switching provides a predictable EMI characteristic. Two external compensation components can be adjusted to set the fastest response time, while allowing the option to use ceramic or electrolytic output capacitors. Externally programmable soft-start capacitor facilitates controlled start-up. The LMZ10505 is a reliable and robust solution with the following features: lossless cycle-by-cycle peak current limit to protect for overcurrent or short-circuit fault, thermal shutdown, input undervoltage lockout, and prebiased start-up.

Device Information⁽¹⁾⁽²⁾

| PART NUMBER | PACKAGE | BODY SIZE (NOM) |
|-------------|-------------|--------------------|
| LMZ10505 | TO-PMOD (7) | 9.85 mm x 10.16 mm |

(1) For all available packages, see the orderable addendum at the end of the data sheet.

(2) Peak reflow temperature equals 245°C. See [Design Summary LMZ1xxx and LMZ2xxx Power Module Family](#) (SNAA214) for more details.

Typical Application Circuit

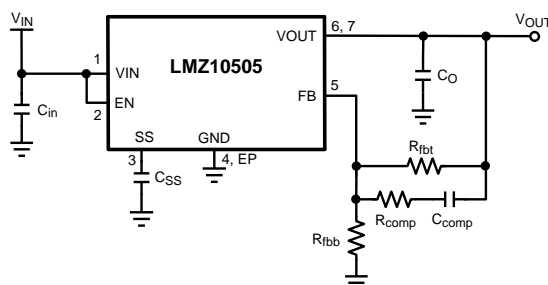

Efficiency $V_{OUT} = 3.3\text{ V}$

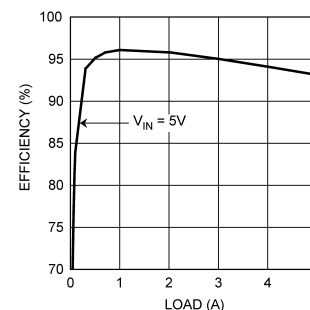

Table of Contents

| | | | |
|--|-----------|--|-----------|
| 1 Features | 1 | 8.2 Typical Application | 14 |
| 2 Applications | 1 | 8.3 System Examples | 20 |
| 3 Description | 1 | 9 Power Supply Recommendations | 23 |
| 4 Revision History | 2 | 10 Layout | 23 |
| 5 Pin Configuration and Functions | 3 | 10.1 Layout Guidelines | 23 |
| 6 Specifications | 4 | 10.2 Layout Examples | 24 |
| 6.1 Absolute Maximum Ratings | 4 | 10.3 Estimate Power Dissipation and Thermal Considerations | 27 |
| 6.2 ESD Ratings | 4 | 10.4 Power Module SMT Guidelines | 28 |
| 6.3 Recommended Operating Conditions | 4 | 11 Device and Documentation Support | 29 |
| 6.4 Thermal Information | 4 | 11.1 Device Support | 29 |
| 6.5 Electrical Characteristics | 5 | 11.2 Documentation Support | 29 |
| 6.6 Typical Characteristics | 7 | 11.3 Receiving Notification of Documentation Updates | 29 |
| 7 Detailed Description | 10 | 11.4 Community Resources | 29 |
| 7.1 Overview | 10 | 11.5 Trademarks | 31 |
| 7.2 Functional Block Diagram | 10 | 11.6 Electrostatic Discharge Caution | 31 |
| 7.3 Feature Description | 10 | 11.7 Glossary | 31 |
| 7.4 Device Functional Modes | 13 | 12 Mechanical, Packaging, and Orderable Information | 31 |
| 8 Application and Implementation | 14 | | |
| 8.1 Application Information | 14 | | |

4 Revision History

NOTE: Page numbers for previous revisions may differ from page numbers in the current version.

| Changes from Revision J (June 2016) to Revision K | Page |
|---|-------------|
| • Editorial changes only; no change to technical data | 1 |

| Changes from Revision I (September 2015) to Revision J | Page |
|---|-------------|
| • Changed language of WEBENCH list item; added additional content and links for WEBENCH further in data sheet | 1 |
| • Updated Equation 1 | 10 |

| Changes from Revision H (October 2013) to Revision I | Page |
|--|-------------|
| • Added <i>ESD Ratings</i> table, <i>Feature Description</i> section, <i>Device Functional Modes</i> , <i>Application and Implementation</i> section, <i>Power Supply Recommendations</i> section, <i>Layout</i> section, <i>Device and Documentation Support</i> section, and <i>Mechanical, Packaging, and Orderable Information</i> section. | 1 |

| Changes from Revision G (April 2013) to Revision H | Page |
|---|-------------|
| • Deleted 10 mils | 4 |
| • Changed 10 mils | 23 |
| • Changed 10 mils | 27 |
| • Added <i>Power Module SMT Guidelines</i> | 28 |

5 Pin Configuration and Functions

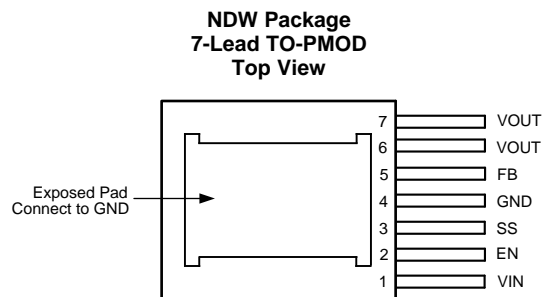

Pin Functions

| PIN | | TYPE | DESCRIPTION |
|-------------|------|--------|---|
| NAME | NO. | | |
| EN | 2 | Analog | Active-high enable input for the device. |
| Exposed Pad | — | Ground | Exposed pad is used as a thermal connection to remove heat from the device. Connect this pad to the PCB ground plane in order to reduce thermal resistance value. EP must also provide a direct electrical connection to the input and output capacitors ground terminals. Connect EP to pin 4. |
| FB | 5 | Analog | Feedback pin. This is the inverting input of the error amplifier used for sensing the output voltage. Keep the copper area of this node small. |
| GND | 4 | Ground | Power ground and signal ground. Provide a direct connection to the EP. Place the bottom feedback resistor as close as possible to GND and FB pin. |
| SS | 3 | Analog | Soft-start control pin. An internal 2- μ A current source charges an external capacitor connected between SS and GND pins to set the output voltage ramp rate during start-up. The SS pin can also be used to configure the tracking feature. |
| VIN | 1 | Power | Power supply input. A low-ESR input capacitance should be located as close as possible to the VIN pin and exposed pad (EP). |
| VOUT | 6, 7 | Power | The output terminal of the internal inductor. Connect the output filter capacitor between VOUT pin and EP. |

6 Specifications

6.1 Absolute Maximum Ratings⁽¹⁾⁽²⁾⁽³⁾

| | MIN | MAX | UNIT |
|---------------------------------------|--------------------|-----|------|
| VIN, VOUT, EN, FB, SS to GND | -0.3 | 6 | V |
| Power Dissipation | Internally Limited | | |
| Junction Temperature | | 150 | °C |
| Peak Reflow Case Temperature (30 sec) | | 245 | °C |
| Storage Temperature, T _{stg} | -65 | 150 | °C |

- (1) Stresses beyond those listed under *Absolute Maximum Ratings* may cause permanent damage to the device. These are stress ratings only, which do not imply functional operation of the device at these or any other conditions beyond those indicated under *Recommended Operating Conditions*. Exposure to absolute-maximum-rated conditions for extended periods may affect device reliability.
- (2) If Military/Aerospace specified devices are required, please contact the Texas Instruments Sales Office/Distributors for availability and specifications.
- (3) For soldering specifications, refer to the [Absolute Maximum Ratings for Soldering](#) (SNOA549).

6.2 ESD Ratings

| | VALUE | UNIT |
|--|-------|------|
| V _(ESD) Electrostatic discharge Human body model (HBM) ⁽¹⁾ | ±2000 | V |

- (1) The human body model is a 100-pF capacitor discharged through a 1.5-kΩ resistor into each pin. Test method is per JESD22-A114S.

6.3 Recommended Operating Conditions

over operating free-air temperature range (unless otherwise noted)

| | MIN | MAX | UNIT |
|--|------|-----|------|
| VIN to GND | 2.95 | 5.5 | V |
| Junction Temperature (T _J) | -40 | 125 | °C |

6.4 Thermal Information

| THERMAL METRIC ⁽¹⁾ | LMZ10505 | UNIT |
|---|---------------|------|
| | NDW (TO-PMOD) | |
| | 7 PINS | |
| R _{θJA} Junction-to-ambient thermal resistance ⁽²⁾ | 20 | °C/W |
| R _{θJC(top)} Junction-to-case (top) thermal resistance (no air flow) | 1.9 | °C/W |

- (1) For more information about traditional and new thermal metrics, see the [Semiconductor and IC Package Thermal Metrics](#) application report.
- (2) R_{θJA} measured on a 2.25-in × 2.25-in (5.8 cm × 5.8 cm) 4-layer board, with 1-oz. copper, thirty six thermal vias, no air flow, and 1-W power dissipation. Refer to [Layout Examples](#) or Evaluation Board Application Note: [AN-2022 LMZ1050x Evaluation Board](#) (SNVA421).

6.5 Electrical Characteristics

Specifications are for $T_J = 25^\circ\text{C}$ unless otherwise specified. Minimum and maximum limits are ensured through test, design, or statistical correlation. Typical values represent the most likely parametric norm at $T_J = 25^\circ\text{C}$, and are provided for reference purposes only. $V_{IN} = V_{EN} = 3.3\text{ V}$, unless otherwise indicated in the conditions column.

| PARAMETER | | TEST CONDITIONS | | MIN ⁽¹⁾ | TYP ⁽²⁾ | MAX ⁽¹⁾ | UNIT |
|--------------------------|---|--|---|---|--------------------|--------------------|---------------|
| SYSTEM PARAMETERS | | | | | | | |
| V_{FB} | Total Feedback Voltage Variation Including Line and Load Regulation | $V_{IN} = 2.95\text{ V to }5.5\text{ V}$ $V_{OUT} = 2.5\text{ V}$ $I_{OUT} = 0\text{ A to }5\text{ A}$ | | 0.8 | | | V |
| | | | over the operating junction temperature range T_J of $-55^\circ\text{C to }125^\circ\text{C}$ | 0.78 | 0.82 | | |
| V_{FB} | Feedback Voltage Variation | $V_{IN} = 3.3\text{ V}, V_{OUT} = 2.5\text{ V}$ $I_{OUT} = 0\text{ A}$ | | 0.8 | | | V |
| | | | over the operating junction temperature range T_J of $-55^\circ\text{C to }125^\circ\text{C}$ | 0.787 | 0.812 | | |
| V_{FB} | Feedback Voltage Variation | $V_{IN} = 3.3\text{ V}, V_{OUT} = 2.5\text{ V}$ $I_{OUT} = 5\text{ A}$ | | 0.798 | | | V |
| | | | over the operating junction temperature range T_J of $-55^\circ\text{C to }125^\circ\text{C}$ | 0.785 | 0.81 | | |
| $V_{IN(UVLO)}$ | Input UVLO Threshold (Measured at V_{IN} pin) | | Rising | | 2.6 | | V |
| | | | | over the operating junction temperature range T_J of $-55^\circ\text{C to }125^\circ\text{C}$ | | 2.95 | |
| | | | Falling | | 2.4 | | |
| | | | | over the operating junction temperature range T_J of $-55^\circ\text{C to }125^\circ\text{C}$ | 1.95 | | |
| I_{SS} | Soft-Start Current | Charging Current | | | 2 | | μA |
| I_Q | Non-Switching Input Current | $V_{FB} = 1\text{ V}$ | | 1.55 | | | mA |
| | | | over the operating junction temperature range T_J of $-55^\circ\text{C to }125^\circ\text{C}$ | | 3 | | |
| I_{SD} | Shutdown Quiescent Current | $V_{IN} = 5.5\text{ V}, V_{EN} = 0\text{ V}$ | | 267 | | | μA |
| | | | over the operating junction temperature range T_J of $-55^\circ\text{C to }125^\circ\text{C}$ | | 500 | | |
| I_{OCL} | Output Current Limit (Average Current) | $V_{OUT} = 2.5\text{ V}$ | | 7.3 | | | A |
| | | | over the operating junction temperature range T_J of $-55^\circ\text{C to }125^\circ\text{C}$ | 5.1 | 8.7 | | |
| f_{FB} | Frequency Fold-back | In current limit | | | 250 | | kHz |
| PWM SECTION | | | | | | | |
| f_{SW} | Switching Frequency | | | 1000 | | | kHz |
| | | over the operating junction temperature range T_J of $-55^\circ\text{C to }125^\circ\text{C}$ | 750 | 1160 | | | |
| D_{range} | PWM Duty Cycle Range | over the operating junction temperature range T_J of $-55^\circ\text{C to }125^\circ\text{C}$ | | 0% | 100% | | |
| ENABLE CONTROL | | | | | | | |
| V_{EN-IH} | EN Pin Rising Threshold | | | 1.23 | | | V |
| | | over the operating junction temperature range T_J of $-55^\circ\text{C to }125^\circ\text{C}$ | | 1.8 | | | |
| V_{EN-IF} | EN Pin Falling Threshold | | | 1.06 | | | V |
| | | over the operating junction temperature range T_J of $-55^\circ\text{C to }125^\circ\text{C}$ | 0.8 | | | | |

(1) Minimum and maximum limits are 100% production tested at an ambient temperature (T_A) of 25°C . Limits over the operating temperature range are ensured through correlation using Statistical Quality Control (SQC) methods. Limits are used to calculate Average Outgoing Quality Level (AOQL).

(2) Typical numbers are at 25°C and represent the most likely parametric norm.

Electrical Characteristics (continued)

Specifications are for $T_J = 25^\circ\text{C}$ unless otherwise specified. Minimum and maximum limits are ensured through test, design, or statistical correlation. Typical values represent the most likely parametric norm at $T_J = 25^\circ\text{C}$, and are provided for reference purposes only. $V_{IN} = V_{EN} = 3.3\text{ V}$, unless otherwise indicated in the conditions column.

| PARAMETER | | TEST CONDITIONS | MIN ⁽¹⁾ | TYP ⁽²⁾ | MAX ⁽¹⁾ | UNIT |
|-------------------------------|--|--|--------------------|--------------------|--------------------|---------------------|
| THERMAL CONTROL | | | | | | |
| T_{SD} | T_J for Thermal Shutdown | | | 145 | | $^\circ\text{C}$ |
| T_{SD-HYS} | Hysteresis for Thermal Shutdown | | | 10 | | $^\circ\text{C}$ |
| PERFORMANCE PARAMETERS | | | | | | |
| ΔV_{OUT} | Output Voltage Ripple | Refer to Table 1 $V_{OUT} = 2.5\text{ V}$ Bandwidth Limit = 2 MHz | | 10 | | mV _{pk-pk} |
| ΔV_{OUT} | Output Voltage Ripple | Refer to Table 5 Bandwidth Limit = 20 MHz | | 5 | | mV _{pk-pk} |
| $\Delta V_{FB} / V_{FB}$ | Feedback Voltage Line Regulation | $\Delta V_{IN} = 2.95\text{ V to } 5.5\text{ V}$ $I_{OUT} = 0\text{ A}$ | | 0.04% | | |
| $\Delta V_{OUT} / V_{OUT}$ | Output Voltage Line Regulation | $\Delta V_{IN} = 2.95\text{ V to } 5.5\text{ V}$ $I_{OUT} = 0\text{ A}, V_{OUT} = 2.5\text{ V}$ | | 0.04% | | |
| $\Delta V_{FB} / V_{FB}$ | Feedback Voltage Load Regulation | $I_{OUT} = 0\text{ A to } 5\text{ A}$ | | 0.25% | | |
| $\Delta V_{OUT} / V_{OUT}$ | Output Voltage Load Regulation | $I_{OUT} = 0\text{ A to } 5\text{ A}$ $V_{OUT} = 2.5\text{ V}$ | | 0.25% | | |
| EFFICIENCY | | | | | | |
| η | Peak Efficiency (1A) $V_{IN} = 5\text{ V}$ | $V_{OUT} = 3.3\text{ V}$ | | 96.1% | | |
| | | $V_{OUT} = 2.5\text{ V}$ | | 94.8% | | |
| | | $V_{OUT} = 1.8\text{ V}$ | | 93.1% | | |
| | | $V_{OUT} = 1.5\text{ V}$ | | 92% | | |
| | | $V_{OUT} = 1.2\text{ V}$ | | 90.4% | | |
| | | $V_{OUT} = 0.8\text{ V}$ | | 86.8% | | |
| η | Peak Efficiency (1A) $V_{IN} = 3.3\text{ V}$ | $V_{OUT} = 2.5\text{ V}$ | | 95.75% | | |
| | | $V_{OUT} = 1.8\text{ V}$ | | 94.1% | | |
| | | $V_{OUT} = 1.5\text{ V}$ | | 93.0% | | |
| | | $V_{OUT} = 1.2\text{ V}$ | | 91.6% | | |
| | | $V_{OUT} = 0.8\text{ V}$ | | 88.3% | | |
| η | Full Load Efficiency (3A) $V_{IN} = 5\text{ V}$ | $V_{OUT} = 3.3\text{ V}$ | | 93.1% | | |
| | | $V_{OUT} = 2.5\text{ V}$ | | 91.2% | | |
| | | $V_{OUT} = 1.8\text{ V}$ | | 88.5% | | |
| | | $V_{OUT} = 1.5\text{ V}$ | | 86.7% | | |
| | | $V_{OUT} = 1.2\text{ V}$ | | 84.1% | | |
| | | $V_{OUT} = 0.8\text{ V}$ | | 78.2% | | |
| η | Full Load Efficiency (3A) $V_{IN} = 3.3\text{ V}$ | $V_{OUT} = 2.5\text{ V}$ | | 89.8% | | |
| | | $V_{OUT} = 1.8\text{ V}$ | | 86.9% | | |
| | | $V_{OUT} = 1.5\text{ V}$ | | 85.1% | | |
| | | $V_{OUT} = 1.2\text{ V}$ | | 82.5% | | |
| | | $V_{OUT} = 0.8\text{ V}$ | | 76.2% | | |

6.6 Typical Characteristics

Unless otherwise specified, the following conditions apply: $V_{IN} = V_{EN} = 5\text{ V}$, C_{IN} is 47- μF 10-V X5R ceramic capacitor; $T_A = 25^\circ\text{C}$ for efficiency curves and waveforms.

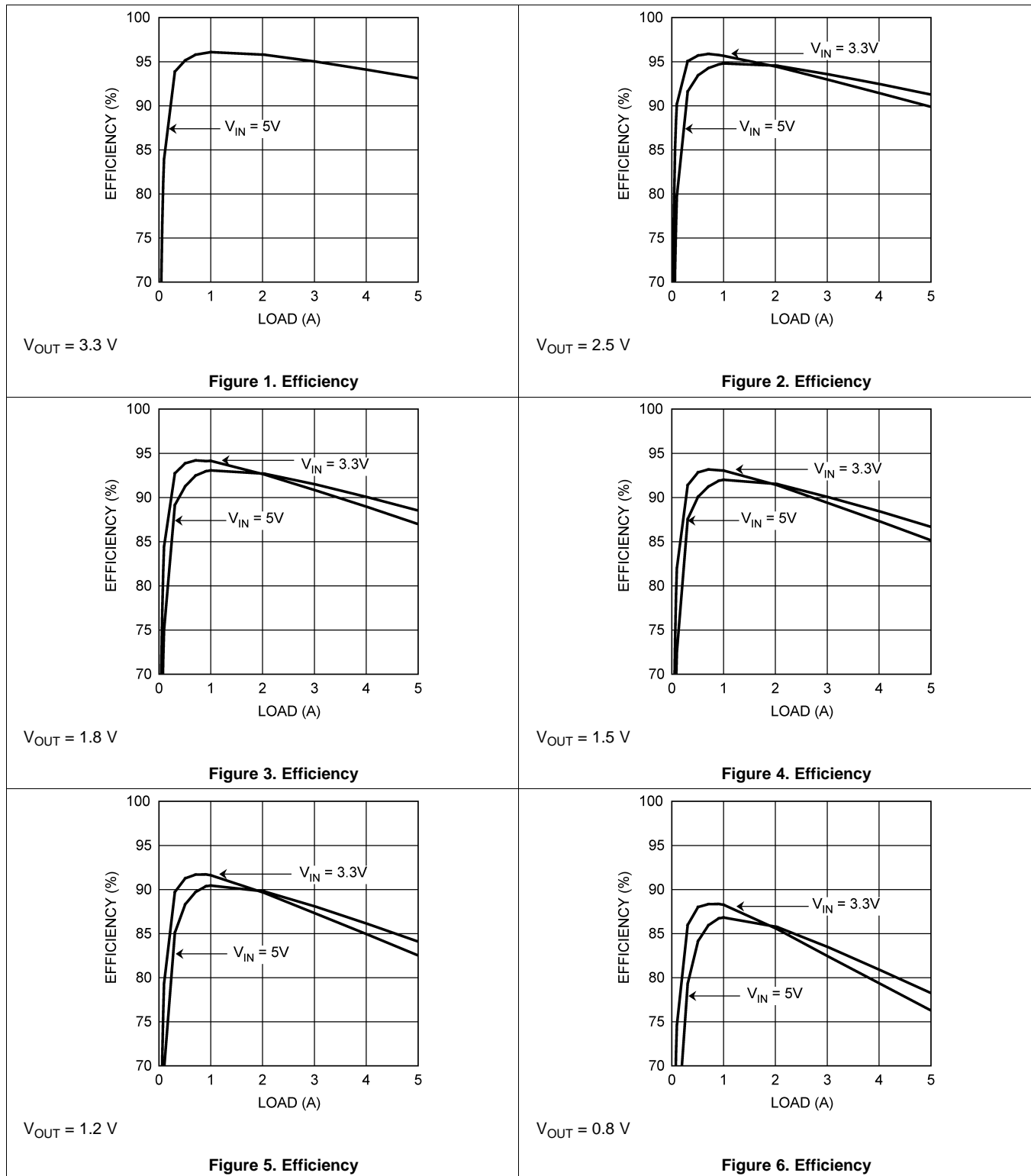

Typical Characteristics (continued)

Unless otherwise specified, the following conditions apply: $V_{IN} = V_{EN} = 5\text{ V}$, C_{IN} is 47- μF 10-V X5R ceramic capacitor; $T_A = 25^\circ\text{C}$ for efficiency curves and waveforms.

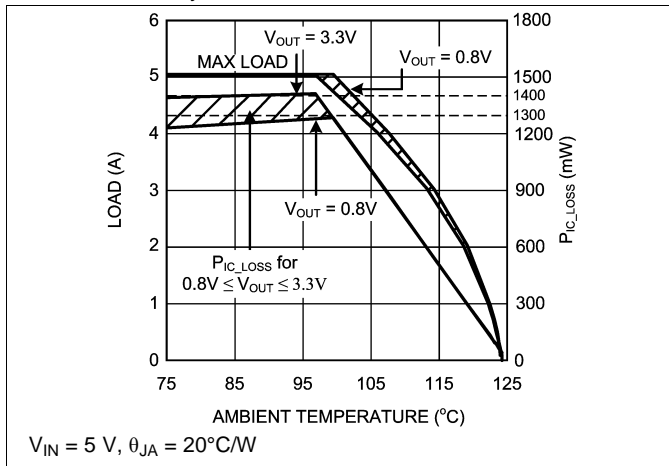

Figure 7. Current Derating

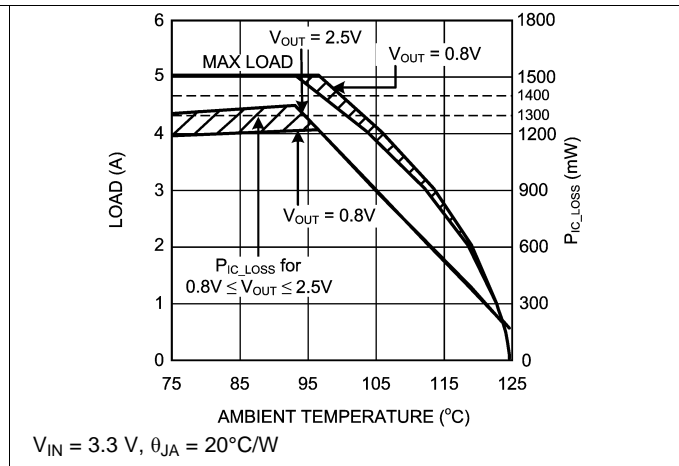

Figure 8. Current Derating

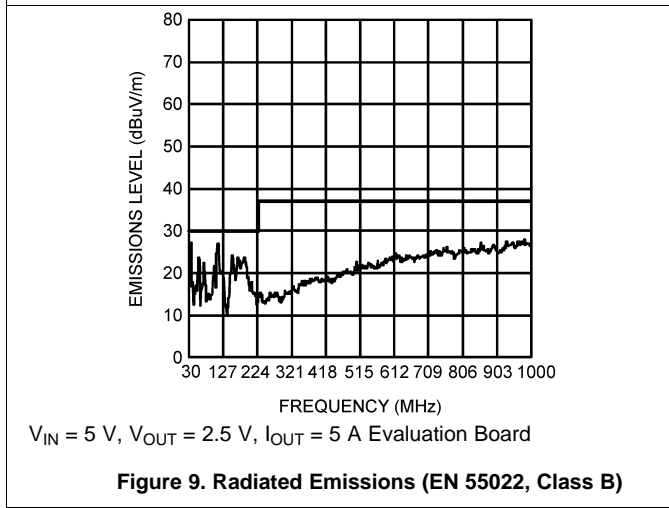

Figure 9. Radiated Emissions (EN 55022, Class B)

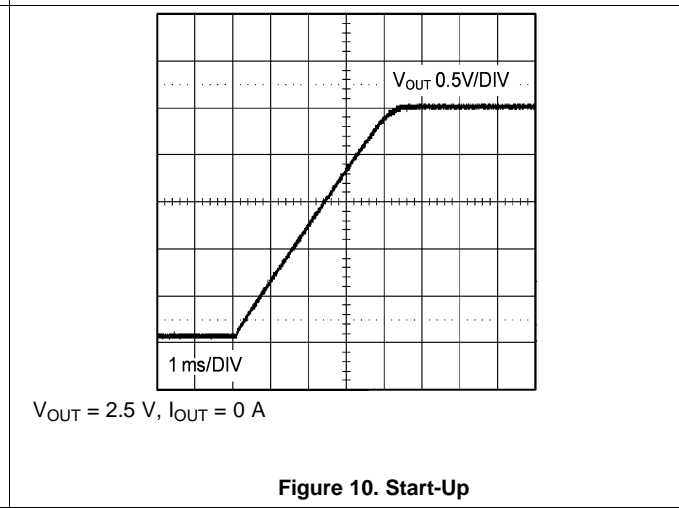

Figure 10. Start-Up

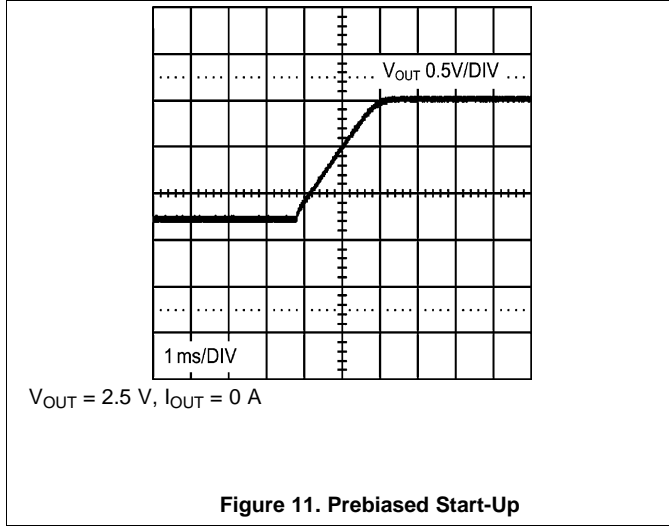

Figure 11. Prebiased Start-Up

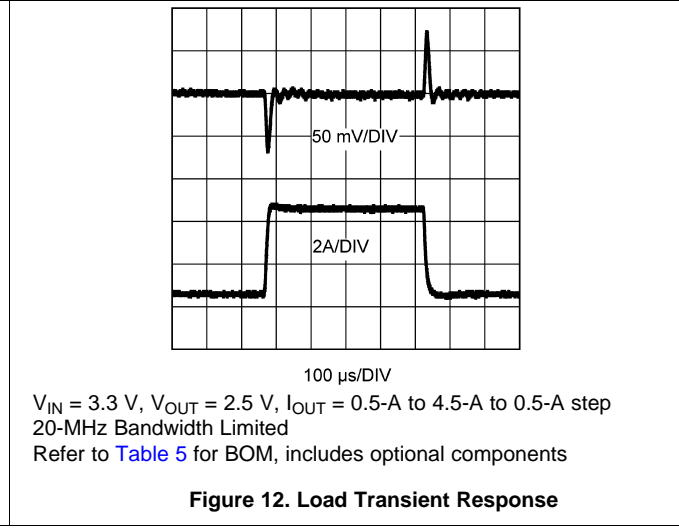
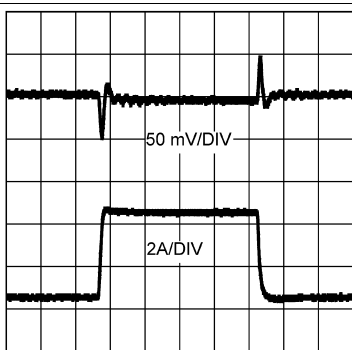

Figure 12. Load Transient Response

Typical Characteristics (continued)

Unless otherwise specified, the following conditions apply: $V_{IN} = V_{EN} = 5\text{ V}$, C_{IN} is 47- μF 10-V X5R ceramic capacitor; $T_A = 25^\circ\text{C}$ for efficiency curves and waveforms.



100 $\mu\text{s}/\text{DIV}$

$V_{IN} = 5.0\text{ V}$, $V_{OUT} = 2.5\text{ V}$, $I_{OUT} = 0.5\text{-A}$ to 4.5-A to 0.5-A step
20-MHz Bandwidth Limited
Refer to [Table 5](#) for BOM, includes optional components

Figure 13. Load Transient Response

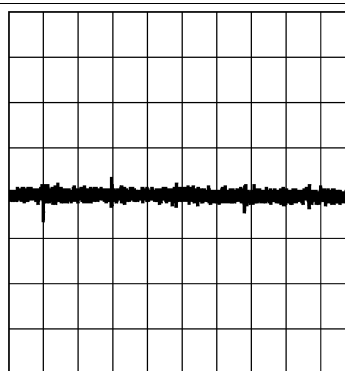

500 ns/DIV

$V_{IN} = 3.3\text{ V}$, $V_{OUT} = 2.5\text{ V}$, $I_{OUT} = 5\text{ A}$, 20 mV/DIV
Refer to [Table 5](#) for BOM

Figure 14. Output Voltage Ripple

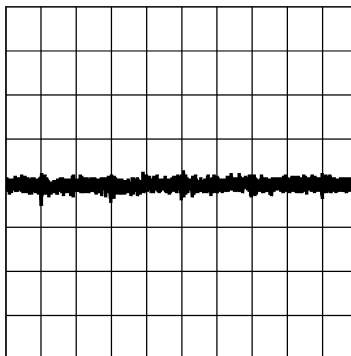

500 ns/DIV

$V_{IN} = 5.0\text{ V}$, $V_{OUT} = 2.5\text{ V}$, $I_{OUT} = 5\text{ A}$,
20 mV/DIV Refer to [Table 5](#) for BOM

Figure 15. Output Voltage Ripple

7 Detailed Description

7.1 Overview

The LMZ10505 power module is a complete, easy-to-use DC-DC solution capable of driving up to a 5-A load with exceptional power conversion efficiency, output voltage accuracy, line and load regulation. The LMZ10505 is available in an innovative package that enhances thermal performance and allows for hand or machine soldering. The LMZ10505 is a reliable and robust solution with the following features: lossless cycle-by-cycle peak current limit to protect for overcurrent or short-circuit fault, thermal shutdown, input undervoltage lockout, and prebiased start-up.

7.2 Functional Block Diagram

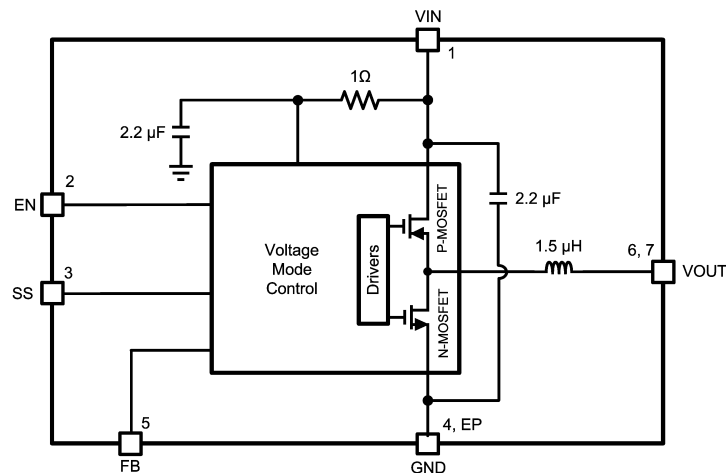

7.3 Feature Description

7.3.1 Enable

The LMZ10505 features an enable (EN) pin and associated comparator to allow the user to easily sequence the LMZ10505 from an external voltage rail, or to manually set the input UVLO threshold. The turnon or rising threshold and hysteresis for this comparator are typically 1.23 V and 0.15 V, respectively. The precise reference for the enable comparator allows the user to ensure that the LMZ10505 will be disabled when the system demands it to be.

The EN pin should not be left floating. For always-on operation, connect EN to VIN.

7.3.2 Enable and UVLO

Using a resistor divider from VIN to EN as shown in the schematic diagram below, the input voltage at which the part begins switching can be increased above the normal input UVLO level according to:

$$V_{IN(UVLO)} = 1.23 \text{ V} \times \frac{R_{ent} + R_{enb}}{R_{enb}} \quad (1)$$

For example, suppose that the required input UVLO level is 3.69 V. Choosing $R_{enb} = 10 \text{ k}\Omega$, then we calculate $R_{ent} = 20 \text{ k}\Omega$.

Feature Description (continued)

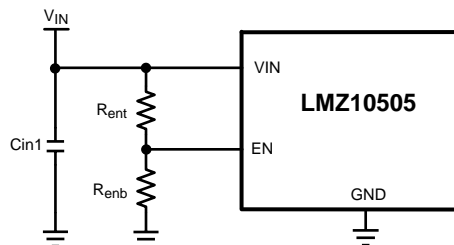

Figure 16. Setting Enable and UVLO

Alternatively, the EN pin can be driven from another voltage source to cater to system sequencing requirements commonly found in FPGA and other multi-rail applications. Figure 17 shows an LMZ10505 that is sequenced to start based on the voltage level of a master system rail (V_{OUT1}).

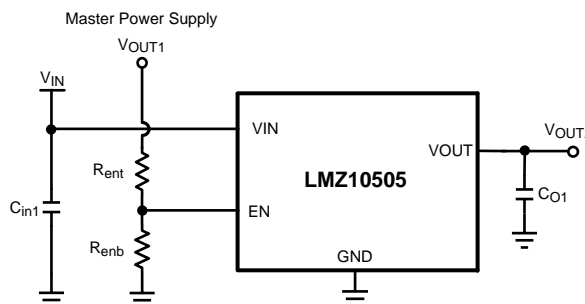

Figure 17. Setting Enable and UVLO Using External Power Supply

7.3.3 Soft-Start

The LMZ10505 begins to operate when both the VIN and EN, voltages exceed the rising UVLO and enable thresholds, respectively. A controlled soft-start eliminates inrush currents during start-up and allows the user more control and flexibility when sequencing the LMZ10505 with other power supplies.

In the event of either VIN or EN decreasing below the falling UVLO or enable threshold respectively, the voltage on the soft-start pin is collapsed by discharging the soft-start capacitor by a 14- μ A (typical) current sink to ground.

7.3.4 Soft-Start Capacitor

Determine the soft-start capacitance with the following relationship:

$$C_{SS} = \frac{t_{SS} \times I_{SS}}{V_{REF}}$$

where

- V_{FB} is the internal reference voltage (nominally 0.8 V),
- I_{SS} is the soft-start charging current (nominally 2 μ A),
- and C_{SS} is the external soft-start capacitance.

(2)

Thus, the required soft-start capacitor per unit output voltage startup time is given by:

$$C_{SS} = 2.5 \text{ nF / ms} \quad (3)$$

For example, a 4-ms soft-start time will yield a 10-nF capacitance. The minimum soft-start capacitance is 680 pF.

Feature Description (continued)

7.3.5 Tracking

The LMZ10505 can track the output of a master power supply during soft-start by connecting a resistor divider to the SS pin. In this way, the output voltage slew rate of the LMZ10505 will be controlled by a master supply for loads that require precise sequencing. When the tracking function is used, a small value soft-start capacitor should be connected to the SS pin to alleviate output voltage overshoot when recovering from a current limit fault.

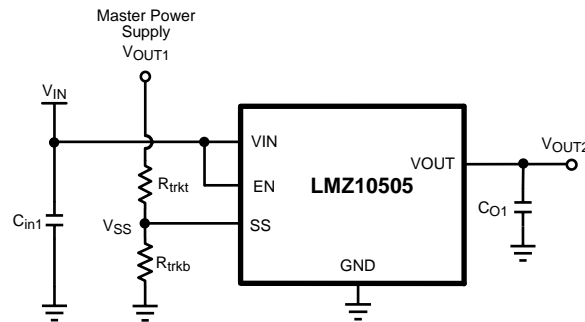

Figure 18. Tracking Using External Power Supply

7.3.6 Tracking - Equal Soft-Start Time

One way to use the tracking feature is to design the tracking resistor divider so that the master supply output voltage, V_{OUT1} , and the LMZ10505 output voltage, V_{OUT2} , both rise together and reach their target values at the same time. This is termed ratiometric start-up. For this case, the equation governing the values of tracking divider resistors R_{trkb} and R_{trkt} is given by:

$$R_{trkb} = \frac{R_{trkt}}{V_{OUT1} - 1.0V} \tag{4}$$

The above equation includes an offset voltage, of 200 mV, to ensure that the final value of the SS pin voltage exceeds the reference voltage of the LMZ10505. This offset will cause the LMZ10505 output voltage to reach regulation slightly before the master supply. For a value of 33 kΩ, 1% is recommended for R_{trkt} as a compromise between high precision and low quiescent current through the divider while minimizing the effect of the 2-μA soft-start current source.

For example, if the master supply voltage V_{OUT1} is 3.3 V and the LMZ10505 output voltage was 1.8 V, then the value of R_{trkb} needed to give the two supplies identical soft-start times would be 14.3 kΩ. Figure 19 shows an example of tracking using the equal soft-start time.

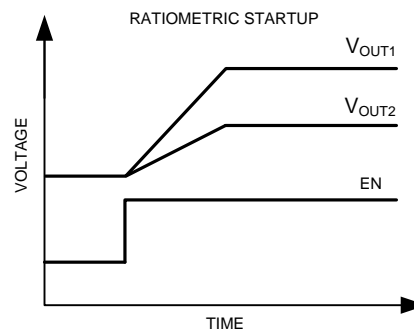

Figure 19. Timing Diagram for Tracking Using Equal Soft-Start Time

Feature Description (continued)

7.3.7 Tracking - Equal Slew Rates

Alternatively, the tracking feature can be used to have similar output voltage ramp rates. This is referred to as simultaneous start-up. In this case, the tracking resistors can be determined based on Equation 5:

$$R_{trkb} = \frac{0.8V}{V_{OUT2} - 0.8V} \times R_{trkt} \quad (5)$$

and to ensure proper overdrive of the SS pin:

$$V_{OUT2} < 0.8 \times V_{OUT1} \quad (6)$$

For the example case of $V_{OUT1} = 5V$ and $V_{OUT2} = 2.5V$, with R_{trkt} set to $33k\Omega$ as before, R_{trkb} is calculated from the above equation to be $15.5k\Omega$. Figure 20 shows an example of tracking using the equal slew rates.

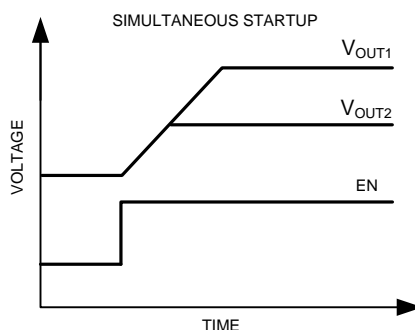

Figure 20. Timing Diagram for Tracking Using Equal Slew Rates

7.3.8 Current Limit

When a current greater than the output current limit (I_{OCL}) is sensed, the ON-time is immediately terminated and the low-side MOSFET is activated. The low-side MOSFET stays on for the entire next four switching cycles. During these skipped pulses, the voltage on the soft-start pin is reduced by discharging the soft-start capacitor by a current sink on the soft-start pin of nominally $14\mu A$. Subsequent overcurrent events will drain more and more charge from the soft-start capacitor, effectively decreasing the reference voltage as the output droops due to the pulse skipping. Reactivation of the soft-start circuitry ensures that when the overcurrent situation is removed, the part will resume normal operation smoothly.

7.3.9 Overtemperature Protection

When the LMZ10505 senses a junction temperature greater than $145^{\circ}C$ (typical), both switching MOSFETs are turned off and the part enters a standby state. Upon sensing a junction temperature below $135^{\circ}C$ (typical), the part will re-initiate the soft-start sequence and begin switching once again.

7.4 Device Functional Modes

7.4.1 Prebias Start-Up Capability

At start-up, the LMZ10505 is in a prebiased state when the output voltage is greater than zero. This often occurs in many multi-rail applications such as when powering an ASIC, FPGA, or DSP. The output can be prebiased in these applications through parasitic conduction paths from one supply rail to another. Even though the LMZ10505 is a synchronous converter, it will not pull the output low when a prebias condition exists. The LMZ10505 will not sink current during start-up until the soft-start voltage exceeds the voltage on the FB pin. Because the device does not sink current it protects the load from damage that might otherwise occur if current is conducted through the parasitic paths of the load.

8 Application and Implementation

NOTE

Information in the following applications sections is not part of the TI component specification, and TI does not warrant its accuracy or completeness. TI's customers are responsible for determining suitability of components for their purposes. Customers should validate and test their design implementation to confirm system functionality.

8.1 Application Information

The LMZ10505 is a step-down DC-to-DC power module. It is typically used to convert a higher DC voltage to a lower DC voltage with a maximum output current of 5 A. The following design procedure can be used to select components for the LMZ10505. Alternately, the WEBENCH software may be used to generate complete designs.

When generating a design, the WEBENCH software uses iterative design procedure and accesses comprehensive databases of components. Please go to www.ti.com for more details.

8.2 Typical Application

This section provides several application solutions with an associated bill of materials. The compensation for each solution was optimized to work over the full input range. Many applications have a fixed input voltage rail. It is possible to modify the compensation to obtain a faster transient response for a given input voltage operating point.

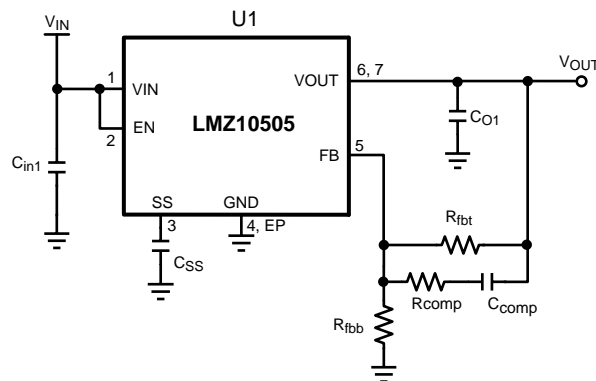

Figure 21. Typical Application Schematic

8.2.1 Design Requirements

For this example the following application parameters exist.

- $V_{IN} = 5\text{ V}$
- $V_{OUT} = 2.5\text{ V}$
- $I_{OUT} = 5\text{ A}$
- $\Delta V_{OUT} = 20\text{ mV}_{pk-pk}$
- $\Delta V_{o_tran} = \pm 20\text{ mV}_{pk-pk}$

Table 1. Bill of Materials, $V_{IN} = 3.3\text{ V}$ to 5 V , $V_{OUT} = 2.5\text{ V}$, $I_{OUT (MAX)} = 5\text{ A}$, Optimized for Electrolytic Input and Output Capacitance

| DESIGNATOR | DESCRIPTION | CASE SIZE | MANUFACTURER | MANUFACTURER P/N | QUANTITY |
|------------|--|-------------------------|-------------------|------------------|----------|
| U1 | Power module | PFM-7 | Texas Instruments | LMZ10505TZ-ADJ | 1 |
| C_{in1} | 150 μF , 6.3 V, 18 m Ω | C2, 6.0 x 3.2 x 1.8 mm | Sanyo | 6TPE150MIC2 | 1 |
| C_{O1} | 330 μF , 6.3 V, 18 m Ω | D3L, 7.3 x 4.3 x 2.8 mm | Sanyo | 6TPE330MIL | 1 |
| R_{fbt} | 100 k Ω | 0603 | Vishay Dale | CRCW0603100KFKEA | 1 |

Typical Application (continued)

Table 1. Bill of Materials, $V_{IN} = 3.3\text{ V}$ to 5 V , $V_{OUT} = 2.5\text{ V}$, $I_{OUT (MAX)} = 5\text{ A}$, Optimized for Electrolytic Input and Output Capacitance (continued)

| DESIGNATOR | DESCRIPTION | CASE SIZE | MANUFACTURER | MANUFACTURER P/N | QUANTITY |
|------------|-------------------------------|-----------|--------------|-------------------|----------|
| R_{fb} | 47.5 k Ω | 0603 | Vishay Dale | CRCW060347K5FKEA | 1 |
| R_{comp} | 15 k Ω | 0603 | Vishay Dale | CRCW060315K0FKEA | 1 |
| C_{comp} | 330 pF, $\pm 5\%$, C0G, 50 V | 0603 | TDK | C1608C0G1H331J | 1 |
| C_{SS} | 10 nF, $\pm 10\%$, X7R, 16 V | 0603 | Murata | GRM188R71C103KA01 | 1 |

Table 2. Bill of Materials, $V_{IN} = 3.3\text{ V}$, $V_{OUT} = 0.8\text{ V}$, $I_{OUT (MAX)} = 5\text{ A}$, Optimized for Solution Size and Transient Response

| DESIGNATOR | DESCRIPTION | CASE SIZE | MANUFACTURER | MANUFACTURER P/N | QUANTITY |
|----------------------|-------------------------------|-----------|-------------------|-------------------|----------|
| U1 | Power module | PFM-7 | Texas Instruments | LMZ10505TZ-ADJ | 1 |
| C_{in1} , C_{O1} | 47 μ F, X5R, 6.3 V | 1206 | TDK | C3216X5R0J476M | 2 |
| R_{fbt} | 110 k Ω | 0402 | Vishay Dale | CRCW0402100KFKEA | 1 |
| R_{comp} | 1.0 k Ω | 0402 | Vishay Dale | CRCW04021K00FKED | 1 |
| C_{comp} | 27 pF, $\pm 5\%$, C0G, 50 V | 0402 | Murata | GRM1555C1H270JZ01 | 1 |
| C_{SS} | 10 nF, $\pm 10\%$, X7R, 16 V | 0402 | Murata | GRM155R71C103KA01 | 1 |

8.2.2 Detailed Design Procedure

LMZ10505 is fully supported by WEBENCH and offers the following: component selection, performance, electrical, and thermal simulations as well as the Build-It board, for a reduced design time. On the other hand, all external components can be calculated by following the design procedure below.

1. Determine the input voltage and output voltage. Also, make note of the ripple voltage and voltage transient requirements.
2. Determine the necessary input and output capacitance.
3. Calculate the feedback resistor divider.
4. Select the optimized compensation component values.
5. Estimate the power dissipation and board thermal requirements.
6. Follow the PCB design guideline.
7. Learn about the LMZ10505 features such as enable, input UVLO, soft-start, tracking, prebiased start-up, current limit, and thermal shutdown.

8.2.2.1 Custom Design With WEBENCH® Tools

[Click here](#) to create a custom design using the LMZ10504 device with the WEBENCH® Power Designer.

1. Start by entering the input voltage (V_{IN}), output voltage (V_{OUT}), and output current (I_{OUT}) requirements.
2. Optimize the design for key parameters such as efficiency, footprint, and cost using the optimizer dial.
3. Compare the generated design with other possible solutions from Texas Instruments.

The WEBENCH Power Designer provides a customized schematic along with a list of materials with real-time pricing and component availability.

In most cases, these actions are available:

- Run electrical simulations to see important waveforms and circuit performance
- Run thermal simulations to understand board thermal performance
- Export customized schematic and layout into popular CAD formats
- Print PDF reports for the design, and share the design with colleagues

Get more information about WEBENCH tools at www.ti.com/WEBENCH.

8.2.2.2 Input Capacitor Selection

A 22- μF or 47- μF high-quality dielectric (X5R, X7R) ceramic capacitor rated at twice the maximum input voltage is typically sufficient. The input capacitor must be placed as close as possible to the VIN pin and GND exposed pad to substantially eliminate the parasitic effects of any stray inductance or resistance on the PCB and supply lines.

Neglecting capacitor equivalent series resistance (ESR), the resultant input capacitor AC ripple voltage is a triangular waveform. The minimum input capacitance for a given peak-to-peak value (ΔV_{IN}) of V_{IN} is specified as follows:

$$C_{\text{in}} \geq \frac{I_{\text{OUT}} \times D \times (1-D)}{f_{\text{sw}} \times \Delta V_{\text{IN}}}$$

where

- the PWM duty cycle, D, is given by [Equation 8](#): (7)

$$D = \frac{V_{\text{OUT}}}{V_{\text{IN}}} \quad (8)$$

If ΔV_{IN} is 1% of V_{IN} , this equals to 50 mV and $f_{\text{sw}} = 1 \text{ MHz}$

$$C_{\text{in}} \geq \frac{5 \text{ A} \times \left(\frac{2.5 \text{ V}}{5 \text{ V}}\right) \times \left(1 - \frac{2.5 \text{ V}}{5 \text{ V}}\right)}{1 \text{ MHz} \times 50 \text{ mV}} \geq 25 \mu\text{F} \quad (9)$$

A second criteria before finalizing the C_{in} bypass capacitor is the RMS current capability. The necessary RMS current rating of the input capacitor to a buck regulator can be estimated by:

$$I_{\text{Cin(RMS)}} = I_{\text{OUT}} \times \sqrt{D(1-D)} \quad (10)$$

$$I_{\text{Cin(RMS)}} = 5 \text{ A} \times \sqrt{\frac{2.5 \text{ V}}{5 \text{ V}} \left(1 - \frac{2.5 \text{ V}}{5 \text{ V}}\right)} = 2.5 \text{ A} \quad (11)$$

With this high AC current present in the input capacitor, the RMS current rating becomes an important parameter. The maximum input capacitor ripple voltage and RMS current occur at 50% duty cycle. Select an input capacitor rated for at least the maximum calculated $I_{\text{Cin(RMS)}}$.

Additional bulk capacitance with higher ESR may be required to damp any resonance effects of the input capacitance and parasitic inductance.

8.2.2.3 Output Capacitor Selection

In general, 22- μF to 100- μF high-quality dielectric (X5R, X7R) ceramic capacitor rated at twice the maximum output voltage is sufficient given the optimal high-frequency characteristics and low ESR of ceramic dielectrics. Although, the output capacitor can also be of electrolytic chemistry for increased capacitance density.

Two output capacitance equations are required to determine the minimum output capacitance. One equation determines the output capacitance (C_{O}) based on PWM ripple voltage. The second equation determines C_{O} based on the load transient characteristics. Select the largest capacitance value of the two.

The minimum capacitance, given the maximum output voltage ripple (ΔV_{OUT}) requirement, is determined by [Equation 12](#):

$$C_{\text{O}} \geq \frac{\Delta i_{\text{L}}}{8 \times f_{\text{sw}} \times [\Delta V_{\text{OUT}} - (\Delta i_{\text{L}} \times R_{\text{ESR}})]}$$

where

- the peak to peak inductor current ripple (Δi_{L}) is equal to [Equation 13](#): (12)

$$\Delta i_{\text{L}} = \frac{(V_{\text{IN}} - V_{\text{OUT}}) \times D}{L \times f_{\text{sw}}} \quad (13)$$

R_{ESR} is the total output capacitor ESR, L is the inductance value of the internal power inductor, where $L = 1.5 \mu\text{H}$, and $f_{SW} = 1 \text{ MHz}$. Therefore, per the design example:

$$\Delta i_L = \frac{(5\text{V} - 2.5\text{V}) \times \frac{2.5\text{V}}{5\text{V}}}{1.5 \mu\text{H} \times 1 \text{ MHz}} = 833 \text{ mA} \quad (14)$$

The minimum output capacitance requirement due to the PWM ripple voltage is:

$$C_O \geq \frac{833 \text{ mA}}{8 \times 1 \text{ MHz} \times [20 \text{ mV} - (833 \text{ mA} \times 3 \text{ m}\Omega)]} \quad (15)$$

$$C_O \geq 6 \mu\text{F} \quad (16)$$

Three $\text{m}\Omega$ is a typical R_{ESR} value for ceramic capacitors.

Equation 17 provides a good first pass capacitance requirement for a load transient:

$$C_O \geq \frac{I_{\text{step}} \times V_{FB} \times L \times V_{IN}}{4 \times V_{OUT} \times (V_{IN} - V_{OUT}) \times \Delta V_{o_tran}}$$

where

- I_{step} is the peak to peak load step (10% to 90% of the maximum load for this example),
 - $V_{FB} = 0.8 \text{ V}$,
 - and ΔV_{o_tran} is the maximum output voltage deviation, which is $\pm 20 \text{ mV}$.
- (17)

Therefore the capacitance requirement for the given design parameters is:

$$C_O \geq \frac{4 \text{ A} \times 0.8 \text{ V} \times 1.5 \mu\text{H} \times 5 \text{ V}}{4 \times 2.5 \text{ V} \times (5 \text{ V} - 2.5 \text{ V}) \times 20 \text{ mV}} \quad (18)$$

$$C_O \geq 48 \mu\text{F} \quad (19)$$

In this particular design the output capacitance is determined by the load transient requirements.

Table 3 lists some examples of commercially available capacitors that can be used with the LMZ10505.

Table 3. Recommended Output Filter Capacitors

| C_O (μF) | VOLTAGE (V), R_{ESR} ($\text{m}\Omega$) | MAKE | MANUFACTURER | PART NUMBER | CASE SIZE |
|-------------------------|---|-----------------|--------------|------------------|-------------------------|
| 22 | 6.3, < 5 | Ceramic, X5R | TDK | C3216X5R0J226M | 1206 |
| 47 | 6.3, < 5 | Ceramic, X5R | TDK | C3216X5R0J476M | 1206 |
| 47 | 6.3, < 5 | Ceramic, X5R | TDK | C3225X5R0J476M | 1210 |
| 47 | 10.0, < 5 | Ceramic, X5R | TDK | C3225X5R1A476M | 1210 |
| 100 | 6.3, < 5 | Ceramic, X5R | TDK | C3225X5R0J107M | 1210 |
| 100 | 6.3, 50 | Tantalum | AVX | TPSD157M006#0050 | D, 7.5 × 4.3 × 2.9 mm |
| 100 | 6.3, 25 | Organic Polymer | Sanyo | 6TPE100MPB2 | B2, 3.5 × 2.8 × 1.9 mm |
| 150 | 6.3, 18 | Organic Polymer | Sanyo | 6TPE150MIC2 | C2, 6.0 × 3.2 × 1.8 mm |
| 330 | 6.3, 18 | Organic Polymer | Sanyo | 6TPE330MIL | D3L, 7.3 × 4.3 × 2.8 mm |
| 470 | 6.3, 23 | Niobium Oxide | AVX | NOME37M006#0023 | E, 7.3 × 4.3 × 4.1 mm |

8.2.2.3.1 Output Voltage Setting

A resistor divider network from V_{OUT} to the FB pin determines the desired output voltage as follows:

$$V_{OUT} = 0.8 \text{ V} \times \frac{R_{fbt} + R_{fbb}}{R_{fbb}} \quad (20)$$

R_{fbt} is defined based on the voltage loop requirements and R_{fbb} is then selected for the desired output voltage. Resistors are normally selected as 0.5% or 1% tolerance. Higher accuracy resistors such as 0.1% are also available.

The feedback voltage (at $V_{OUT} = 2.5\text{ V}$) is accurate to within $-2.5\% / +2.5\%$ over temperature and over line and load regulation. Additionally, the LMZ10505 contains error nulling circuitry to substantially eliminate the feedback voltage variation over temperature as well as the long-term aging effects of the internal amplifiers. In addition the zero nulling circuit dramatically reduces the $1/f$ noise of the bandgap amplifier and reference. The manifestation of this circuit action is that the duty cycle will have two slightly different but distinct operating points, each evident every other switching cycle.

8.2.2.4 Loop Compensation

The LMZ10505 preserves flexibility by integrating the control components around the internal error amplifier while utilizing three small external compensation components from V_{OUT} to FB. An integrated type II (two pole, one zero) voltage-mode compensation network is featured. To ensure stability, an external resistor and small value capacitor can be added across the upper feedback resistor as a pole-zero pair to complete a type III (three pole, two zero) compensation network. The compensation components recommended in Table 4 provide type III compensation at an optimal control loop performance. The typical phase margin is 45° with a bandwidth of 80 kHz. Calculated output capacitance values not listed in Table 4 should be verified before designing into production. The AN-2013 LMZ1050x/LMZ1050xEXT SIMPLE SWITCHER Power Module (SNVA417) is a detailed application note that provides verification support. In general, calculated output capacitance values below the suggested value will have reduced phase margin and higher control loop bandwidth. Output capacitance values above the suggested values will experience a lower bandwidth and increased phase margin. Higher bandwidth is associated with faster system response to sudden changes such as load transients. Phase margin changes the characteristics of the response. Lower phase margin is associated with underdamped ringing and higher phase margin is associated with overdamped response. Losing all phase margin will cause the system to be unstable; an optimized area of operation is 30° to 60° of phase margin, with a bandwidth of 100 kHz ± 20 kHz.

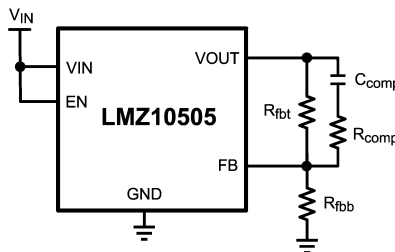

Figure 22. Loop Compensation Control Components

Table 4. LMZ10505 Compensation Component Values

| V_{IN} (V) | C_O (μF) | ESR (m Ω) | | R_{fbt} (k Ω) ⁽¹⁾ | C_{comp} (pF) ⁽¹⁾ | R_{comp} (k Ω) ⁽¹⁾ |
|--------------|-------------------------|-------------------|-----|--|--------------------------------|---|
| | | MIN | MAX | | | |
| 5 | 22 | 2 | 20 | 200 | 27 | 1.5 |
| | 47 | 2 | 20 | 124 | 68 | 1.4 |
| | 100 | 1 | 10 | 82.5 | 150 | 0.681 |
| | 150 | 1 | 5 | 63.4 | 220 | 1 |
| | 150 | 10 | 25 | 63.4 | 220 | 3.48 |
| | 150 | 26 | 50 | 226 | 62 | 12.1 |
| | 220 | 15 | 30 | 150 | 100 | 6.98 |
| | 220 | 31 | 60 | 316 | 560 | 14 |

(1) In the special case where the output voltage is 0.8 V, TI recommends to remove R_{fbb} and keep R_{fbt} , R_{comp} , and C_{comp} for a type III compensation.

Table 4. LMZ10505 Compensation Component Values (continued)

| V _{IN} (V) | C _O (μF) | ESR (mΩ) | | R _{fbt} (kΩ) ⁽¹⁾ | C _{comp} (pF) ⁽¹⁾ | R _{comp} (kΩ) ⁽¹⁾ |
|---------------------|---------------------|----------|-----|--------------------------------------|---------------------------------------|---------------------------------------|
| | | MIN | MAX | | | |
| 3.3 | 22 | 2 | 20 | 118 | 43 | 9.09 |
| | 47 | 2 | 20 | 76.8 | 100 | 3.32 |
| | 100 | 1 | 10 | 49.9 | 180 | 2.49 |
| | 150 | 1 | 5 | 40.2 | 330 | 1 |
| | 150 | 10 | 25 | 43.2 | 330 | 4.99 |
| | 150 | 26 | 50 | 143 | 100 | 7.5 |
| | 220 | 15 | 30 | 100 | 180 | 4.99 |
| | 220 | 31 | 60 | 200 | 100 | 8.06 |

8.2.3 Application Curves

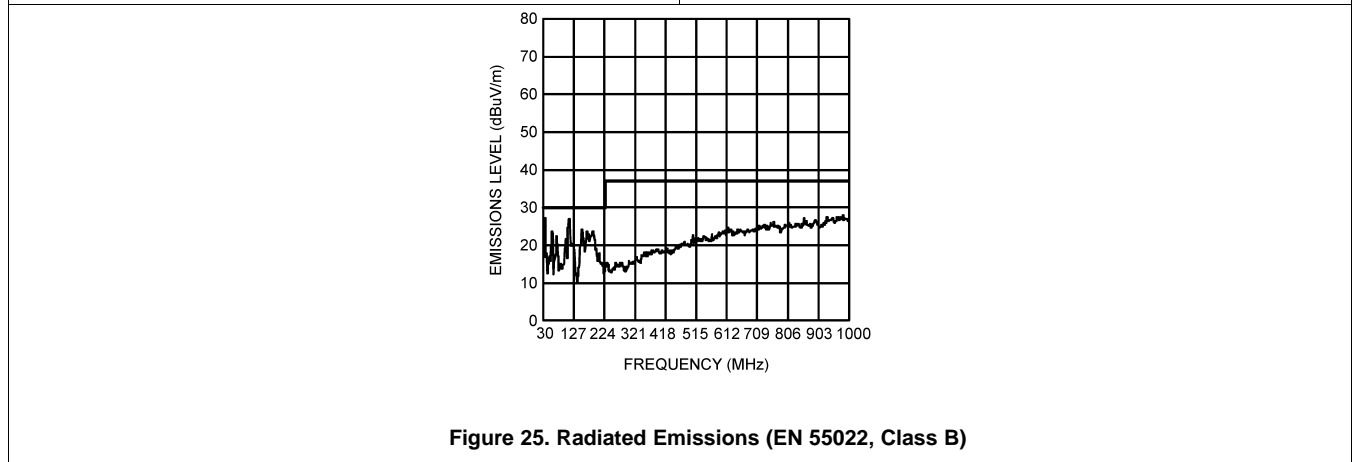
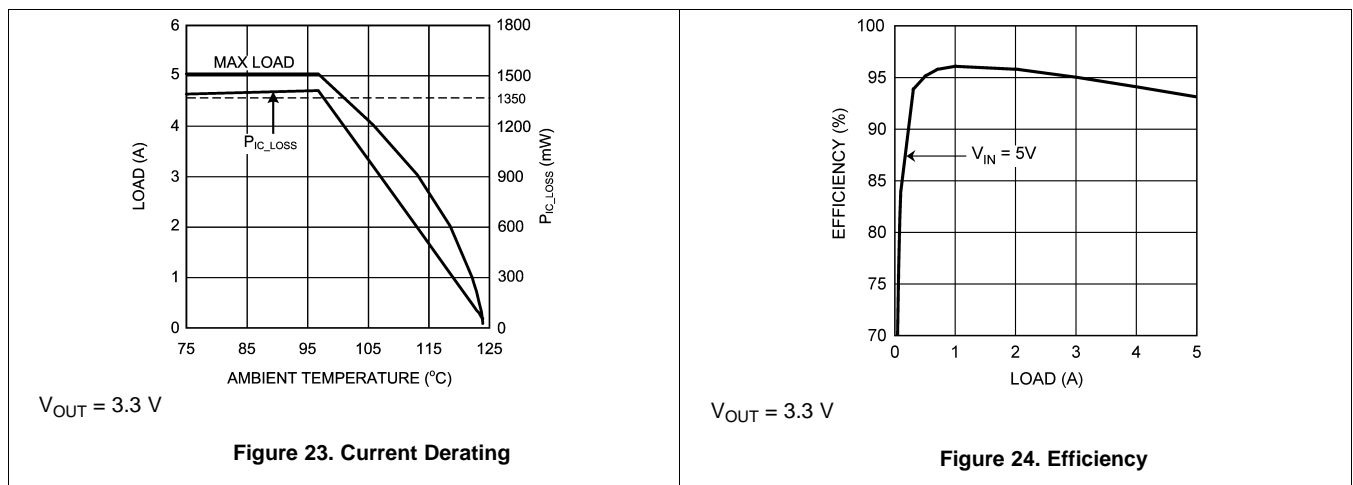

8.3 System Examples

8.3.1 Application Schematic for 3.3-V to 5-V Input and 2.5-V Output With Optimized Ripple and Transient Response

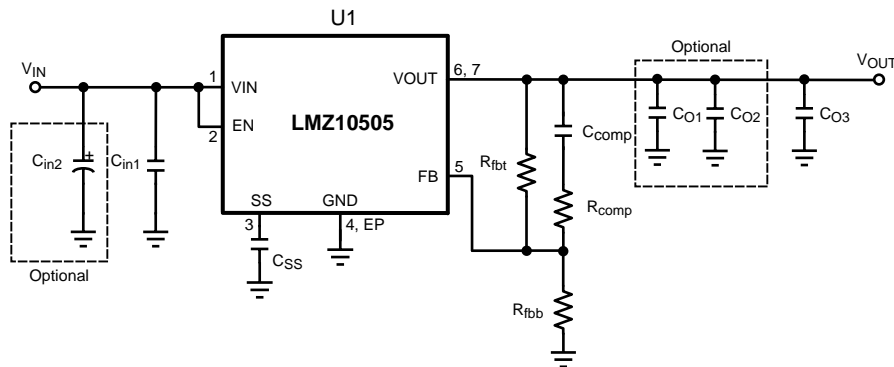

Figure 26. Schematic for 2.5-V Output Based on 3.3-V to 5-V Input

Table 5. Bill of Materials, $V_{IN} = 3.3\text{ V to }5\text{ V}$, $V_{OUT} = 2.5\text{ V}$, $I_{OUT (MAX)} = 5\text{ A}$, Optimized for Low Input and Output Ripple Voltage and Fast Transient Response

| DESIGNATOR | DESCRIPTION | CASE SIZE | MANUFACTURER | MANUFACTURER P/N | QUANTITY |
|------------|-----------------------------------|-----------|-------------------|-------------------|----------|
| U1 | Power module | PFM-7 | Texas Instruments | LMZ10505TZ-ADJ | 1 |
| C_{in1} | 22 μF , X5R, 10 V | 1210 | AVX | 1210ZD226MAT | 2 |
| C_{in2} | 220 μF , 10 V, AL-Elec | E | Panasonic | EEE1AA221AP | 1* |
| C_{O1} | 4.7 μF , X5R, 10 V | 0805 | AVX | 0805ZD475MAT | 1* |
| C_{O2} | 22 μF , X5R, 6.3 V | 1206 | AVX | 12066D226MAT | 1* |
| C_{O3} | 100 μF , X5R, 6.3 V | 1812 | AVX | 18126D107MAT | 1 |
| R_{fbt} | 75 k Ω | 0402 | Vishay Dale | CRCW040275K0FKED | 1 |
| R_{fbb} | 34.8 k Ω | 0402 | Vishay Dale | CRCW040234K8FKED | 1 |
| R_{comp} | 1.0 k Ω | 0402 | Vishay Dale | CRCW04021K00FKED | 1 |
| C_{comp} | 100 pF, $\pm 5\%$, C0G, 50 V | 0402 | Murata | GRM1555C1H101JZ01 | 1 |
| C_{SS} | 10 nF, $\pm 10\%$, X7R, 16 V | 0402 | Murata | GRM155R71C103KA01 | 1 |

Table 6. Output Voltage Setting ($R_{fbt} = 75\text{ k}\Omega$)

| V_{OUT} | R_{fbb} |
|-----------|-----------------|
| 2.5 V | 34.8 k Ω |
| 1.8 V | 59 k Ω |
| 1.5 V | 84.5 k Ω |
| 1.2 V | 150 k Ω |
| 0.9 V | 590 k Ω |

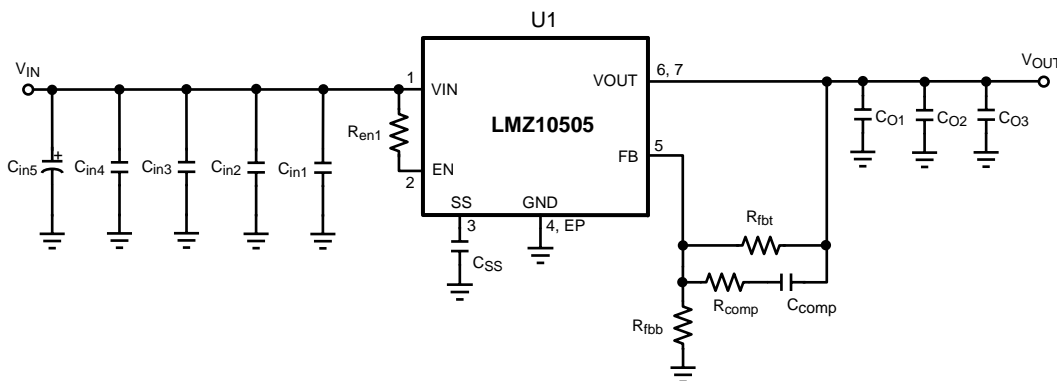
8.3.2 Application Schematic for 3.3-V to 5-V Input and 2.5-V Output

Figure 27. Schematic for 2.5-V Output Based on 3.3-V to 5-V Input
Table 7. Bill of Materials, $V_{IN} = 3.3\text{ V to }5\text{ V}$, $V_{OUT} = 2.5\text{ V}$, $I_{OUT (MAX)} = 5\text{ A}$

| DESIGNATOR | DESCRIPTION | CASE SIZE | MANUFACTURER | MANUFACTURER P/N | QUANTITY |
|------------------------------------|-----------------------------------|-----------|-------------------|------------------|----------|
| U1 | Power module | PFM-7 | Texas Instruments | LMZ10505TZ-ADJ | 1 |
| C _{in1} | 1 μF , X7R, 16 V | 0805 | TDK | C2012X7R1C105K | 1 |
| C _{in2} , C _{O1} | 4.7 μF , X5R, 6.3 V | 0805 | TDK | C2012X5R0J475K | 2 |
| C _{in3} , C _{O2} | 22 μF , X5R, 16 V | 1210 | TDK | C3225X5R1C226M | 2 |
| C _{in4} | 47 μF , X5R, 6.3 V | 1210 | TDK | C3225X5R0J476M | 1 |
| C _{in5} | 220 μF , 10 V, AL-Elec | E | Panasonic | EEE1AA221AP | 1 |
| C _{O3} | 100 μF , X5R, 6.3 V | 1812 | TDK | C4532X5R0J107M | 1 |
| R _{fbt} | 75 k Ω | 0805 | Vishay Dale | CRCW080575K0FKEA | 1 |
| R _{fbb} | 34.8 k Ω | 0805 | Vishay Dale | CRCW080534K8FKEA | 1 |
| R _{comp} | 1.1 k Ω | 0805 | Vishay Dale | CRCW08051K10FKEA | 1 |
| C _{comp} | 180 pF, $\pm 5\%$, C0G, 50 V | 0603 | TDK | C1608C0G1H181J | 1 |
| R _{en1} | 100 k Ω | 0805 | Vishay Dale | CRCW0805100KFKEA | 1 |
| C _{SS} | 10 nF, $\pm 5\%$, C0G, 50 V | 0805 | TDK | C2012C0G1H103J | 1 |

Table 8. Output Voltage Setting ($R_{fbt} = 75\text{ k}\Omega$)

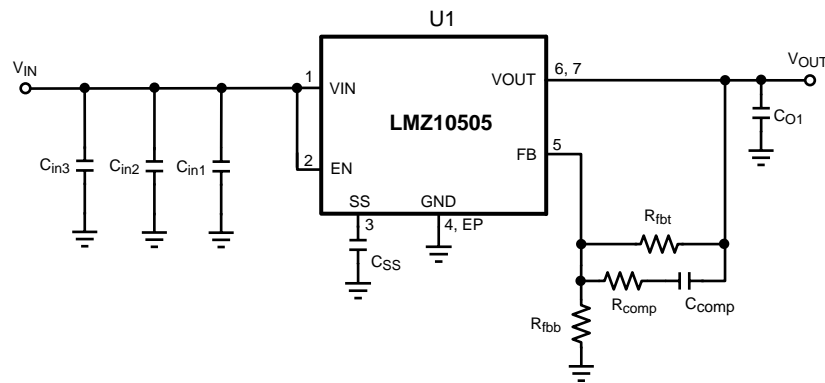
| V _{OUT} | R _{fbb} |
|------------------|------------------|
| 2.5 V | 34.8 k Ω |
| 1.8 V | 59 k Ω |
| 1.5 V | 84.5 k Ω |
| 1.2 V | 150 k Ω |
| 0.9 V | 590 k Ω |

8.3.3 EMI Tested Schematic for 2.5-V Output Based on 3.3-V to 5-V Input

Figure 28. EMI Tested Schematic for 2.5-V Output Based on 3.3-V to 5-V Input
Table 9. Bill of Materials, $V_{IN} = 5\text{ V}$, $V_{OUT} = 2.5\text{ V}$, $I_{OUT(MAX)} = 5\text{ A}$, Tested With EN55022 Class B Radiated Emissions

| DESIGNATOR | DESCRIPTION | CASE SIZE | MANUFACTURER | MANUFACTURER P/N | QUANTITY |
|------------|--------------------------------|-----------|-------------------|------------------|----------|
| U1 | Power module | PFM-7 | Texas Instruments | LMZ10505TZ-ADJ | 1 |
| C_{in1} | 1 μF , X7R, 16 V | 0805 | TDK | C2012X7R1C105K | 1 |
| C_{in2} | 4.7 μF , X5R, 6.3 V | 0805 | TDK | C2012X5R0J475K | 1 |
| C_{in3} | 47 μF , X5R, 6.3 V | 1210 | TDK | C3225X5R0J476M | 1 |
| C_{O1} | 100 μF , X5R, 6.3 V | 1812 | TDK | C4532X5R0J107M | 1 |
| R_{fbt} | 75 k Ω | 0805 | Vishay Dale | CRCW080575K0FKEA | 1 |
| R_{fb} | 34.8 k Ω | 0805 | Vishay Dale | CRCW080534K8FKEA | 1 |
| R_{comp} | 1.1 k Ω | 0805 | Vishay Dale | CRCW08051K10FKEA | 1 |
| C_{comp} | 180 pF, $\pm 5\%$, C0G, 50 V | 0603 | TDK | C1608C0G1H181J | 1 |
| C_{SS} | 10 nF, $\pm 5\%$, C0G, 50 V | 0805 | TDK | C2012C0G1H103J | 1 |

Table 10. Output Voltage Setting ($R_{fbt} = 75\text{ k}\Omega$)

| V_{OUT} | R_{fb} |
|-----------|-----------------|
| 3.3 V | 23.7 k Ω |
| 2.5 V | 34.8 k Ω |
| 1.8 V | 59 k Ω |
| 1.5 V | 84.5 k Ω |
| 1.2 V | 150 k Ω |
| 0.9 V | 590 k Ω |

9 Power Supply Recommendations

The LMZ10505 device is designed to operate from an input voltage supply range between 2.95 V and 5.5 V. This input supply should be well regulated and able to withstand maximum input current and maintain a stable voltage. The resistance of the input supply rail should be low enough that an input current transient does not cause a high enough drop at the LMZ10505 supply voltage that can cause a false UVLO fault triggering and system reset. If the input supply is more than a few inches from the LMZ10505, additional bulk capacitance may be required in addition to the ceramic bypass capacitors. The amount of bulk capacitance is not critical, but a 47- μ F or 100- μ F electrolytic capacitor is a typical choice.

10 Layout

10.1 Layout Guidelines

PCB layout is an important part of DC-DC converter design. Poor board layout can disrupt the performance of a DC-DC converter and surrounding circuitry by contributing to EMI, ground bounce and resistive voltage drop in the traces. These can send erroneous signals to the DC-DC converter resulting in poor regulation or instability. Good layout can be implemented by following a few simple design rules.

1. Minimize area of switched current loops.

From an EMI reduction standpoint, it is imperative to minimize the high di/dt current paths. The high current that does not overlap contains high di/dt, see [Figure 29](#). Therefore physically place input capacitor (C_{in1}) as close as possible to the LMZ10505 VIN pin and GND exposed pad to avoid observable high frequency noise on the output pin. This will minimize the high di/dt area and reduce radiated EMI. Additionally, grounding for both the input and output capacitor should consist of a localized top side plane that connects to the GND exposed pad (EP).

2. Have a single point ground.

The ground connections for the feedback, soft-start, and enable components should be routed only to the GND pin of the device. This prevents any switched or load currents from flowing in the analog ground traces. If not properly placed, poor grounding can result in degraded load regulation or erratic output voltage ripple behavior. Provide the single point ground connection from pin 4 to EP.

3. Minimize trace length to the FB pin.

Both feedback resistors, R_{fbt} and R_{fbb} , and the compensation components, R_{comp} and C_{comp} , should be located close to the FB pin. Since the FB node is high impedance, keep the copper area as small as possible. This is most important as relatively high-value resistors are used to set the output voltage.

4. Make input and output bus connections as wide as possible.

This reduces any voltage drops on the input or output of the converter and maximizes efficiency. To optimize voltage accuracy at the load, ensure that a separate feedback voltage sense trace is made at the load. Doing so will correct for voltage drops and provide optimum output accuracy.

5. Provide adequate device heat-sinking.

Use an array of heat-sinking vias to connect the exposed pad to the ground plane on the bottom PCB layer. If the PCB has multiple copper layers, thermal vias can also be employed to make connection to inner layer heat-spreading ground planes. For best results use a 6 × 6 via array with minimum via diameter of 8 mils thermal vias spaced 59 mils (1.5 mm). Ensure enough copper area is used for heat-sinking to keep the junction temperature below 125°C.

LMZ10505

SNVS633K –JANUARY 2010–REVISED APRIL 2019

www.ti.com

10.2 Layout Examples

The PCB design is available in the LMZ10505 product folder at www.ti.com.

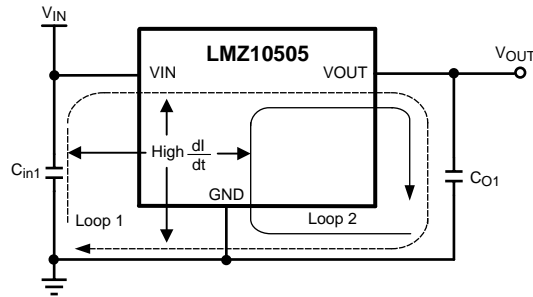

Figure 29. Critical Current Loops to Minimize

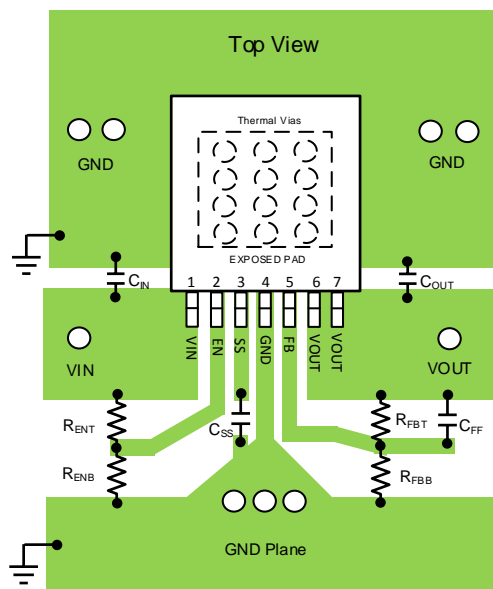

Figure 30. PCB Layout Guide

Layout Examples (continued)

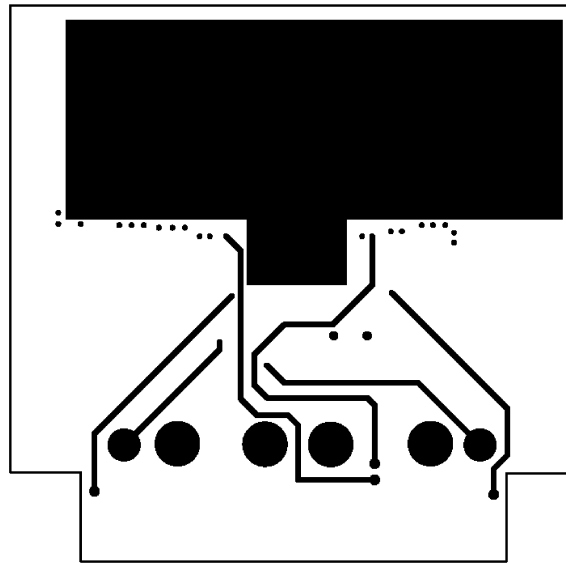

Figure 33. Internal Layer 2 (Ground and Signal Traces)

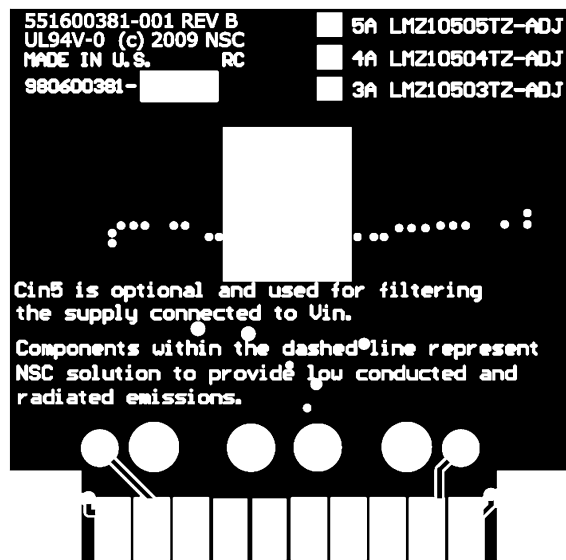

Figure 34. Bottom Copper

10.3 Estimate Power Dissipation and Thermal Considerations

Use the current derating curves in the [Typical Characteristics](#) section to obtain an estimate of power loss (P_{IC_LOSS}). For the design case of $V_{IN} = 5\text{ V}$, $V_{OUT} = 2.5\text{ V}$, $I_{OUT} = 5\text{ A}$, $T_{A(MAX)} = 85^\circ\text{C}$, and $T_{J(MAX)} = 125^\circ\text{C}$, the device must see a thermal resistance from case to ambient (θ_{CA}) of less than:

$$\theta_{CA} \geq \frac{T_{J(MAX)} - T_{A(MAX)}}{P_{IC_LOSS}} - \theta_{JC} \quad (21)$$

$$\theta_{CA} < \frac{125^\circ\text{C} - 85^\circ\text{C}}{1.36\text{ W}} - 1.9 \frac{^\circ\text{C}}{\text{W}} < 27.5 \frac{^\circ\text{C}}{\text{W}} \quad (22)$$

Given the typical thermal resistance from junction to case (θ_{JC}) to be 1.9°C/W (typ.). Continuously operating at a T_J greater than 125°C will have a shorten life span.

To reach $\theta_{CA} = 27.5^\circ\text{C/W}$, the PCB is required to dissipate heat effectively. With no airflow and no external heat, a good estimate of the required board area covered by 1-oz. copper on both the top and bottom metal layers is:

$$\text{Board Area}_{\text{cm}^2} \geq \frac{500}{\theta_{CA}} \times \frac{^\circ\text{C} \times \text{cm}^2}{\text{W}} \quad (23)$$

$$\text{Board Area}_{\text{cm}^2} \geq \frac{500}{27.5 \frac{^\circ\text{C}}{\text{W}}} \times \frac{^\circ\text{C} \times \text{cm}^2}{\text{W}} \quad (24)$$

As a result, approximately 18 square cm of 1-oz. copper on top and bottom layers is required for the PCB design.

The PCB copper heat sink must be connected to the exposed pad (EP). Approximately thirty six, 8 mils thermal vias spaced 59 mils (1.5 mm) apart must connect the top copper to the bottom copper. For an extended discussion and formulations of thermal rules of thumb, refer to [AN-2020 Thermal Design By Insight, Not Hindsight](#) (SNVA419). For an example of a high thermal performance PCB layout with θ_{JA} of 20°C/W , refer to the evaluation board application note [AN-2022 LMZ1050x Evaluation Board](#) (SNVA421) and for results of a study of the effects of the PCB designs, refer to [AN-2026 Effect of PCB Design on Thermal Performance of SIMPLE SWITCHER Power Modules](#) (SNVA424).

10.4 Power Module SMT Guidelines

The recommendations below are for a standard module surface mount assembly

- Land Pattern – Follow the PCB land pattern with either soldermask defined or non-soldermask defined pads
- Stencil Aperture
 - For the exposed die attach pad (DAP), adjust the stencil for approximately 80% coverage of the PCB land pattern
 - For all other I/O pads use a 1:1 ratio between the aperture and the land pattern recommendation
- Solder Paste – Use a standard SAC Alloy such as SAC 305, type 3 or higher
- Stencil Thickness – 0.125 to 0.15 mm
- Reflow - Refer to solder paste supplier recommendation and optimized per board size and density
- Maximum number of reflows allowed is one
- Refer to *Design Summary LMZ1xxx and LMZ2xxx Power Modules Family* (SNAA214) for reflow information.

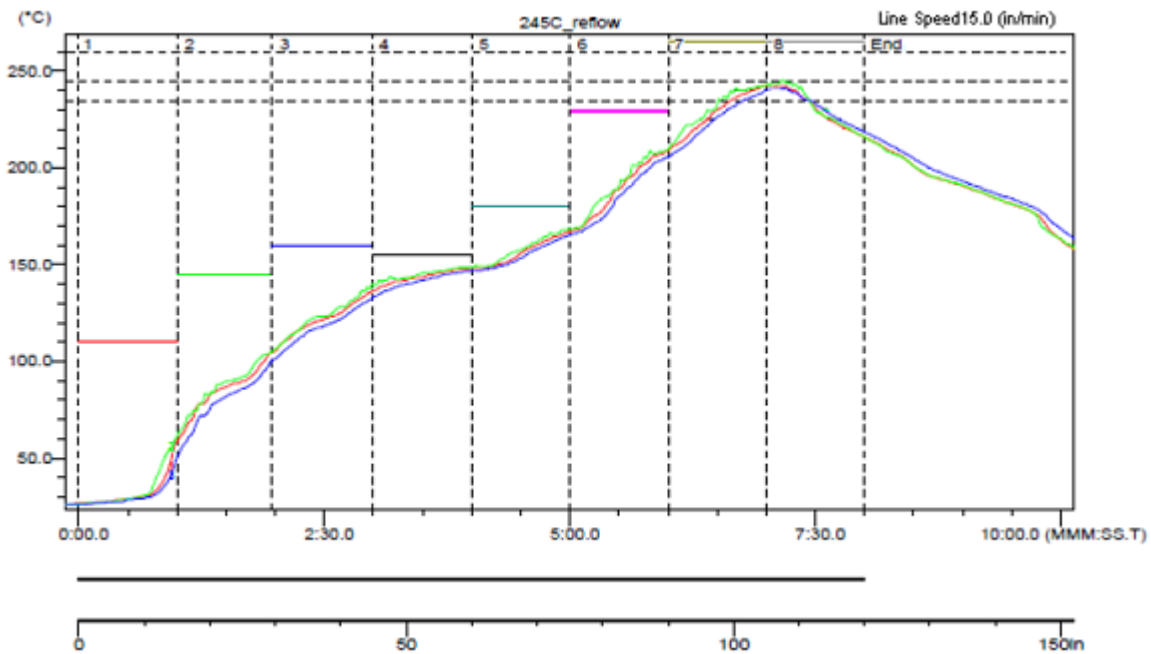

Figure 35. Sample Reflow Profile

Table 11. Sample Reflow Profile Table

| PROBE | MAX TEMP (°C) | REACHED MAX TEMP | TIME ABOVE 235°C | REACHED 235°C | TIME ABOVE 245°C | REACHED 245°C | TIME ABOVE 260°C | REACHED 260°C |
|-------|---------------|------------------|------------------|---------------|------------------|---------------|------------------|---------------|
| 1 | 242.5 | 6.58 | 0.49 | 6.39 | 0.00 | – | 0.00 | – |
| 2 | 242.5 | 7.10 | 0.55 | 6.31 | 0.00 | 7.10 | 0.00 | – |
| 3 | 241.0 | 7.09 | 0.42 | 6.44 | 0.00 | – | 0.00 | – |

11 Device and Documentation Support

11.1 Device Support

11.1.1 Third-Party Products Disclaimer

TI'S PUBLICATION OF INFORMATION REGARDING THIRD-PARTY PRODUCTS OR SERVICES DOES NOT CONSTITUTE AN ENDORSEMENT REGARDING THE SUITABILITY OF SUCH PRODUCTS OR SERVICES OR A WARRANTY, REPRESENTATION OR ENDORSEMENT OF SUCH PRODUCTS OR SERVICES, EITHER ALONE OR IN COMBINATION WITH ANY TI PRODUCT OR SERVICE.

11.1.2 Development Support

11.1.2.1 Custom Design With WEBENCH® Tools

[Click here](#) to create a custom design using the LMZ10505 device with the WEBENCH® Power Designer.

1. Start by entering the input voltage (V_{IN}), output voltage (V_{OUT}), and output current (I_{OUT}) requirements.
2. Optimize the design for key parameters such as efficiency, footprint, and cost using the optimizer dial.
3. Compare the generated design with other possible solutions from Texas Instruments.

The WEBENCH Power Designer provides a customized schematic along with a list of materials with real-time pricing and component availability.

In most cases, these actions are available:

- Run electrical simulations to see important waveforms and circuit performance
- Run thermal simulations to understand board thermal performance
- Export customized schematic and layout into popular CAD formats
- Print PDF reports for the design, and share the design with colleagues

Get more information about WEBENCH tools at www.ti.com/WEBENCH.

11.2 Documentation Support

11.2.1 Related Documentation

For related documentation, see the following:

- [AN-2027 Inverting Application for the LMZ14203 SIMPLE SWITCHER Power Module](#) (SNVA425)
- [Absolute Maximum Ratings for Soldering](#) (SNOA549)
- [AN-2022 LMZ1050x Evaluation Board](#) (SNVA421)
- [AN-2013 LMZ1050x/LMZ1050xEXT SIMPLE SWITCHER Power Module](#) (SNVA417)
- [AN-2024 LMZ1420x / LMZ1200x Evaluation Board](#) (SNVA422)
- [AN-2020 Thermal Design By Insight, Not Hindsight](#) (SNVA419)
- [AN-2026 Effect of PCB Design on Thermal Performance of SIMPLE SWITCHER Power Modules](#) (SNVA424)
- [Design Summary LMZ1xxx and LMZ2xxx Power Modules Family](#) (SNAA214)

11.3 Receiving Notification of Documentation Updates

To receive notification of documentation updates, navigate to the device product folder on ti.com. In the upper right corner, click on *Alert me* to register and receive a weekly digest of any product information that has changed. For change details, review the revision history included in any revised document.

11.4 Community Resources

The following links connect to TI community resources. Linked contents are provided "AS IS" by the respective contributors. They do not constitute TI specifications and do not necessarily reflect TI's views; see TI's [Terms of Use](#).

TI E2E™ Online Community *TI's Engineer-to-Engineer (E2E) Community*. Created to foster collaboration among engineers. At e2e.ti.com, you can ask questions, share knowledge, explore ideas and help solve problems with fellow engineers.

Community Resources (continued)

Design Support *TI's Design Support* Quickly find helpful E2E forums along with design support tools and contact information for technical support.

11.5 Trademarks

E2E is a trademark of Texas Instruments.
WEBENCH is a registered trademark of Texas Instruments.
All other trademarks are the property of their respective owners.

11.6 Electrostatic Discharge Caution



These devices have limited built-in ESD protection. The leads should be shorted together or the device placed in conductive foam during storage or handling to prevent electrostatic damage to the MOS gates.

11.7 Glossary

[SLYZ022](#) — *TI Glossary*.

This glossary lists and explains terms, acronyms, and definitions.

12 Mechanical, Packaging, and Orderable Information

The following pages include mechanical, packaging, and orderable information. This information is the most current data available for the designated devices. This data is subject to change without notice and revision of this document. For browser-based versions of this data sheet, refer to the left-hand navigation.

PACKAGING INFORMATION

| Orderable Device | Status (1) | Package Type | Package Drawing | Pins | Package Qty | Eco Plan (2) | Lead/Ball Finish (6) | MSL Peak Temp (3) | Op Temp (°C) | Device Marking (4/5) | Samples |
|----------------------|---------------|--------------|-----------------|------|-------------|---------------------|-------------------------|----------------------|--------------|-------------------------|-------------------------|
| LMZ10505TZ-ADJ/NOPB | ACTIVE | TO-PMOD | NDW | 7 | 250 | RoHS Exempt & Green | CU SN | Level-3-245C-168 HR | -40 to 125 | LMZ10505 TZ-ADJ | Samples |
| LMZ10505TZE-ADJ/NOPB | ACTIVE | TO-PMOD | NDW | 7 | 45 | RoHS Exempt & Green | CU SN | Level-3-245C-168 HR | -40 to 125 | LMZ10505 TZ-ADJ | Samples |
| LMZ10505TZX-ADJ/NOPB | ACTIVE | TO-PMOD | NDW | 7 | 500 | RoHS Exempt & Green | CU SN | Level-3-245C-168 HR | -40 to 125 | LMZ10505 TZ-ADJ | Samples |

(1) The marketing status values are defined as follows:

ACTIVE: Product device recommended for new designs.

LIFEBUY: TI has announced that the device will be discontinued, and a lifetime-buy period is in effect.

NRND: Not recommended for new designs. Device is in production to support existing customers, but TI does not recommend using this part in a new design.

PREVIEW: Device has been announced but is not in production. Samples may or may not be available.

OBSELETE: TI has discontinued the production of the device.

(2) **RoHS:** TI defines "RoHS" to mean semiconductor products that are compliant with the current EU RoHS requirements for all 10 RoHS substances, including the requirement that RoHS substance do not exceed 0.1% by weight in homogeneous materials. Where designed to be soldered at high temperatures, "RoHS" products are suitable for use in specified lead-free processes. TI may reference these types of products as "Pb-Free".

RoHS Exempt: TI defines "RoHS Exempt" to mean products that contain lead but are compliant with EU RoHS pursuant to a specific EU RoHS exemption.

Green: TI defines "Green" to mean the content of Chlorine (Cl) and Bromine (Br) based flame retardants meet JS709B low halogen requirements of <=1000ppm threshold. Antimony trioxide based flame retardants must also meet the <=1000ppm threshold requirement.

(3) MSL, Peak Temp. - The Moisture Sensitivity Level rating according to the JEDEC industry standard classifications, and peak solder temperature.

(4) There may be additional marking, which relates to the logo, the lot trace code information, or the environmental category on the device.

(5) Multiple Device Markings will be inside parentheses. Only one Device Marking contained in parentheses and separated by a "-" will appear on a device. If a line is indented then it is a continuation of the previous line and the two combined represent the entire Device Marking for that device.

(6) Lead/Ball Finish - Orderable Devices may have multiple material finish options. Finish options are separated by a vertical ruled line. Lead/Ball Finish values may wrap to two lines if the finish value exceeds the maximum column width.

Important Information and Disclaimer:The information provided on this page represents TI's knowledge and belief as of the date that it is provided. TI bases its knowledge and belief on information provided by third parties, and makes no representation or warranty as to the accuracy of such information. Efforts are underway to better integrate information from third parties. TI has taken and continues to take reasonable steps to provide representative and accurate information but may not have conducted destructive testing or chemical analysis on incoming materials and chemicals. TI and TI suppliers consider certain information to be proprietary, and thus CAS numbers and other limited information may not be available for release.

In no event shall TI's liability arising out of such information exceed the total purchase price of the TI part(s) at issue in this document sold by TI to Customer on an annual basis.

TAPE AND REEL INFORMATION

QUADRANT ASSIGNMENTS FOR PIN 1 ORIENTATION IN TAPE

*All dimensions are nominal

| Device | Package Type | Package Drawing | Pins | SPQ | Reel Diameter (mm) | Reel Width W1 (mm) | A0 (mm) | B0 (mm) | K0 (mm) | P1 (mm) | W (mm) | Pin1 Quadrant |
|---------------------|--------------|-----------------|------|-----|--------------------|--------------------|---------|---------|---------|---------|--------|---------------|
| LMZ10505TZ-ADJ/NOPB | TO-PMOD | NDW | 7 | 250 | 330.0 | 24.4 | 10.6 | 14.22 | 5.0 | 16.0 | 24.0 | Q2 |
| LMZ10505TZ-ADJ/NOPB | TO-PMOD | NDW | 7 | 500 | 330.0 | 24.4 | 10.6 | 14.22 | 5.0 | 16.0 | 24.0 | Q2 |

TAPE AND REEL BOX DIMENSIONS



*All dimensions are nominal

| Device | Package Type | Package Drawing | Pins | SPQ | Length (mm) | Width (mm) | Height (mm) |
|----------------------|--------------|-----------------|------|-----|-------------|------------|-------------|
| LMZ10505TZ-ADJ/NOPB | TO-PMOD | NDW | 7 | 250 | 367.0 | 367.0 | 45.0 |
| LMZ10505TZX-ADJ/NOPB | TO-PMOD | NDW | 7 | 500 | 367.0 | 367.0 | 45.0 |

NDW0007A

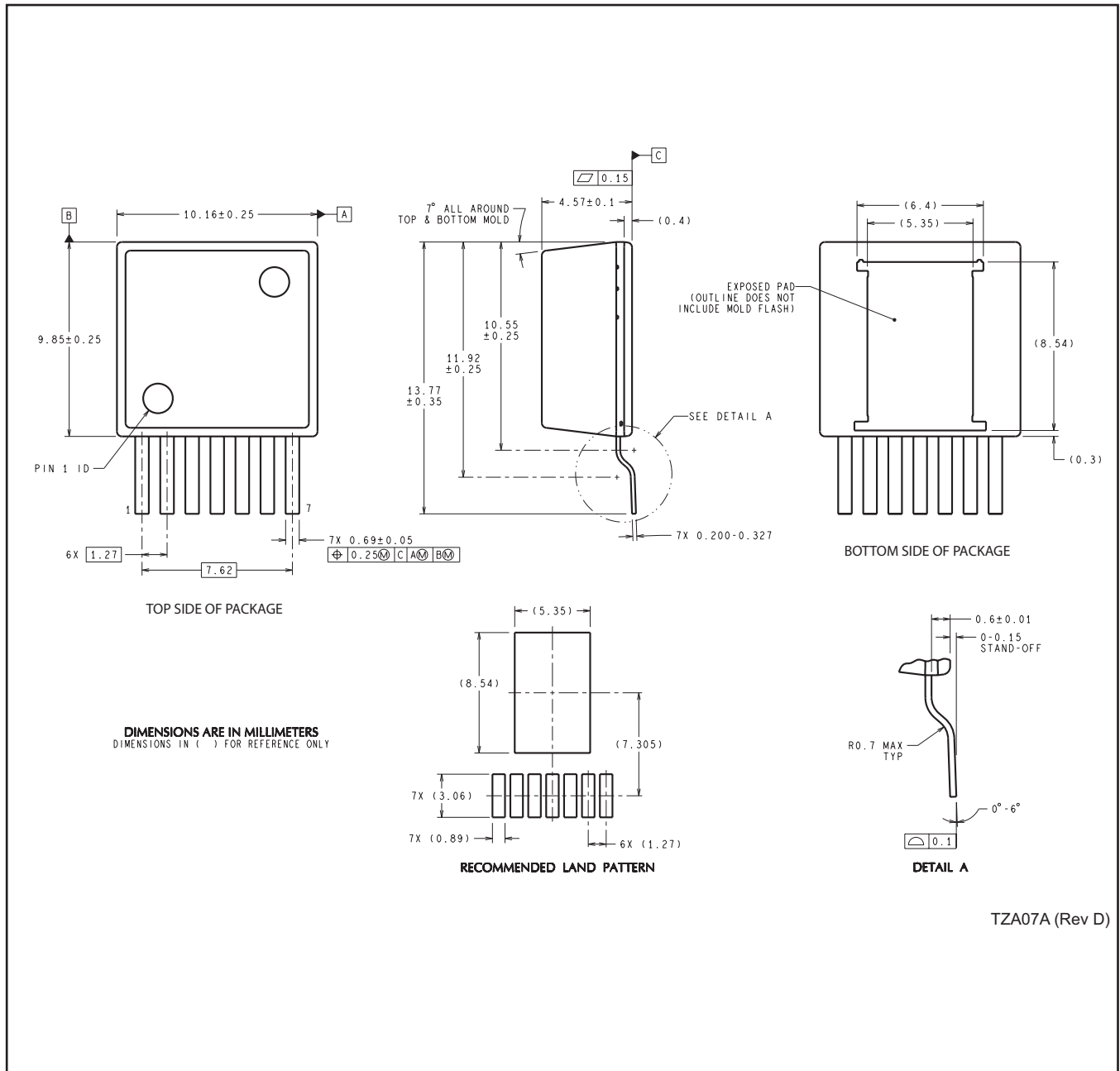

TZA07A (Rev D)

IMPORTANT NOTICE AND DISCLAIMER

TI PROVIDES TECHNICAL AND RELIABILITY DATA (INCLUDING DATASHEETS), DESIGN RESOURCES (INCLUDING REFERENCE DESIGNS), APPLICATION OR OTHER DESIGN ADVICE, WEB TOOLS, SAFETY INFORMATION, AND OTHER RESOURCES "AS IS" AND WITH ALL FAULTS, AND DISCLAIMS ALL WARRANTIES, EXPRESS AND IMPLIED, INCLUDING WITHOUT LIMITATION ANY IMPLIED WARRANTIES OF MERCHANTABILITY, FITNESS FOR A PARTICULAR PURPOSE OR NON-INFRINGEMENT OF THIRD PARTY INTELLECTUAL PROPERTY RIGHTS.

These resources are intended for skilled developers designing with TI products. You are solely responsible for (1) selecting the appropriate TI products for your application, (2) designing, validating and testing your application, and (3) ensuring your application meets applicable standards, and any other safety, security, or other requirements. These resources are subject to change without notice. TI grants you permission to use these resources only for development of an application that uses the TI products described in the resource. Other reproduction and display of these resources is prohibited. No license is granted to any other TI intellectual property right or to any third party intellectual property right. TI disclaims responsibility for, and you will fully indemnify TI and its representatives against, any claims, damages, costs, losses, and liabilities arising out of your use of these resources.

TI's products are provided subject to TI's Terms of Sale (www.ti.com/legal/termsofsale.html) or other applicable terms available either on ti.com or provided in conjunction with such TI products. TI's provision of these resources does not expand or otherwise alter TI's applicable warranties or warranty disclaimers for TI products.

Mailing Address: Texas Instruments, Post Office Box 655303, Dallas, Texas 75265
Copyright © 2019, Texas Instruments Incorporated

Looking for pricing, stock, or lifecycle information?

Click below to explore more details on WIN SOURCE:

- ⊖ [View LMZ10505TZ-ADJ/NOPB on WIN SOURCE](#)
- ⊖ [Texas Instruments](#) Information

Optimize Your Supply Chain with WIN SOURCE Solutions

- ✓ Global Sourcing Solution
- ✓ Obsolete Management
- ✓ Cost Control Management
- ✓ Shortage Management
- ✓ Alternative Solution
- ✓ Excess Inventory Management