



**THE DATASHEET OF
LP38690SD-2.5/NOPB**



LP38690, LP38692 1-A Low Dropout CMOS Linear Regulators

Stable with Ceramic Output Capacitors

1 Features

- Wide Input Voltage Range (2.7 V to 10 V)
- 2.5% Output Accuracy (25°C)
- Low Dropout Voltage: 450 mV at 1 A (typical, 5 V_{OUT})
- Precision (Trimmed) Bandgap Reference
- Ensured Specifications for –40°C to 125°C
- 1-μA Off-State Quiescent Current
- Thermal Overload Protection
- Foldback Current Limiting
- 3-Lead TO-252, 5-Lead SOT-223, and 6-Bump WSON Packages
- Enable Pin (LP38692)
- Ground Pin Current: 55 μA (typical) at Full Load
- Precision Output Voltage: 2.5% (25°C) Accuracy

2 Applications

- Hard Disk Drives
- Notebook Computers
- Battery Powered Devices
- Portable Instrumentation

3 Description

The LP38690 and LP38692 low-dropout CMOS linear regulators provide tight output tolerance (2.5% typical), extremely low dropout voltage (450 mV at a 1-A load current, V_{OUT} = 5 V), and excellent AC performance utilizing ultra low ESR ceramic output capacitors.

The low thermal resistance of the WSON, SOT-223, and TO-252 packages allow the full operating current to be used even in high ambient temperature environments.

The use of a PMOS power transistor means that no DC base drive current is required to bias it allowing ground pin current to remain below 100 μA regardless of load current, input voltage, or operating temperature.

Device Information⁽¹⁾

PART NUMBER	PACKAGE	BODY SIZE (NOM)
LP38690	TO-252 (3)	6.58 mm x 6.10 mm
	WSON (6)	3.00 mm x 3.00 mm
LP38692	SOT-223 (5)	6.50 mm x 3.56 mm
	WSON (6)	3.00 mm x 3.00 mm

(1) For all available packages, see the orderable addendum at the end of the data sheet.

Simplified Schematic for LP38690

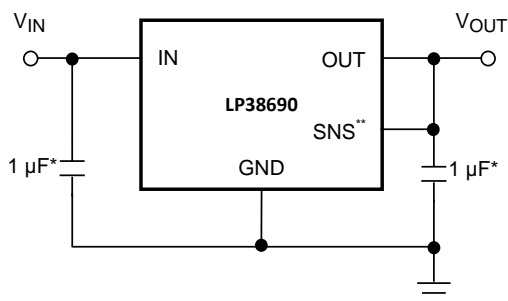

* Minimum value required for stability.

**WSON package devices only.

Simplified Schematic for LP38692

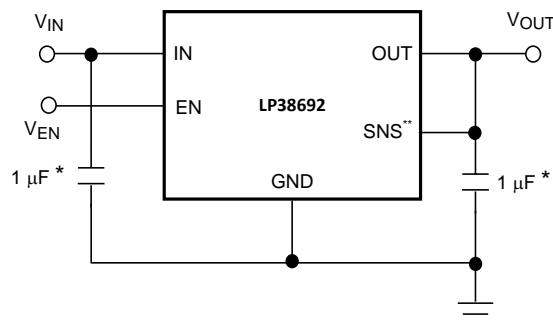

* Minimum value required for stability.

**WSON package devices only.



Table of Contents

1 Features 1 2 Applications 1 3 Description 1 4 Revision History 2 5 Pin Configuration and Functions 3 6 Specifications 4 6.1 Absolute Maximum Ratings 4 6.2 ESD Ratings 4 6.3 Recommended Operating Conditions 4 6.4 Thermal Information 4 6.5 Electrical Characteristics 5 6.6 Typical Characteristics 6 7 Detailed Description 11 7.1 Overview 11 7.2 Functional Block Diagrams 11 7.3 Feature Description 13 7.4 Device Functional Modes 13 8 Application and Implementation 14	8.1 Application Information 14 8.2 Typical Applications 15 9 Power Supply Recommendations 18 10 Layout 18 10.1 PCB Layout 18 10.2 Layout Examples 19 10.3 WSON Mounting 19 10.4 RFI/EMI Susceptibility 20 10.5 Output Noise 20 11 Device and Documentation Support 21 11.1 Documentation Support 21 11.2 Related Links 21 11.3 Community Resources 21 11.4 Trademarks 21 11.5 Electrostatic Discharge Caution 21 11.6 Glossary 21 12 Mechanical, Packaging, and Orderable Information 21
--	--

4 Revision History

NOTE: Page numbers for previous revisions may differ from page numbers in the current version.

Changes from Revision L (March 2015) to Revision M	Page
• Added top navigator icon for TI Designs	1
• Added Caution note to <i>Foldback Current Limiting</i> subsection	13

Changes from Revision K (December 2014) to Revision L	Page
• Changed "mA" back to "mV" - error from SDS conversion.	5

Changes from Revision J (April 2013) to Revision K	Page
• Changed <i>Device Information</i> and <i>ESD Rating</i> tables, <i>Feature Description</i> , <i>Device Functional Modes</i> , <i>Application and Implementation</i> , <i>Power Supply Recommendations</i> , <i>Layout</i> , <i>Device and Documentation Support</i> , and <i>Mechanical, Packaging, and Orderable Information</i> sections; update <i>Thermal Values</i> moved some curves to <i>Application Curves</i> section; change package name PFM to TO-252 (National to TI nomenclature) and pin names from VIN, VOUT to IN, OUT.	1

Changes from Revision I (April 2013) to Revision J	Page
• Changed layout of National Data Sheet to TI format	20

5 Pin Configuration and Functions

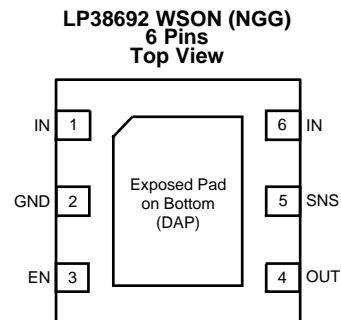
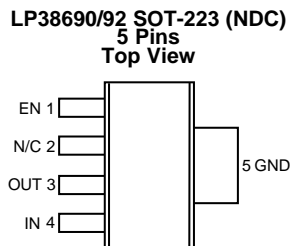
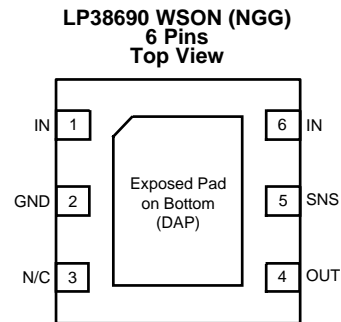
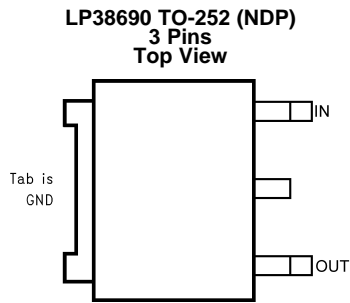

Pin Functions

NAME	PIN				TYPE	DESCRIPTION
	LP38690		LP38692			
	TO-252	WSON	SOT-223	WSON		
EN	—	—	1	3	I	The Enable (EN) pin allows the part to be turned ON and OFF by pulling this pin HIGH or LOW.
GND	TAB	2	5	2	—	Circuit ground for the regulator. For the TO-252 and SOT-223 packages this is thermally connected to the die and functions as a heat sink when soldered down to a large copper plane.
IN	3	1, 6	4	1, 6	I	This is the input supply voltage to the regulator. For WSON devices, both IN pins must be tied together for full current operation (500 mA maximum per pin).
OUT	1	4	3	4	O	Regulated output voltage.
SNS	—	5	—	5	I	WSON only - Output sense pin allows remote sensing at the load which eliminates the error in output voltage due to voltage drops caused by the resistance in the traces between the regulator and the load. This pin must be tied to VOUT.
DAP	—	X	—	X	—	WSON only - The DAP (Exposed Pad) functions as a thermal connection when soldered to a copper plane. See WSON Mounting section in Layout for more information.

6 Specifications

6.1 Absolute Maximum Ratings

over operating free-air temperature range (unless otherwise noted)⁽¹⁾

	MIN	MAX	UNIT
V(max) All pins (with respect to GND)	-0.3	12	V
I _{OUT} ⁽²⁾	Internally limited		
Junction temperature	-40	150	°C
Lead temperature (soldering, 5 seconds)		260	
Power dissipation ⁽³⁾	Internally limited		
Storage temperature, T _{stg}	-65	150	°C

- (1) Stresses beyond those listed under *Absolute Maximum Ratings* may cause permanent damage to the device. These are stress ratings only, which do not imply functional operation of the device at these or any other conditions beyond those indicated under *Recommended Operating Conditions*. Exposure to absolute-maximum-rated conditions for extended periods may affect device reliability.
- (2) If used in a dual-supply system where the regulator load is returned to a negative supply, the output pin must be diode clamped to ground.
- (3) At elevated temperatures, device power dissipation must be derated based on package thermal resistance and heatsink values (if a heatsink is used). When using the WSON package, refer to TI Application Report AN-1187 *Leadless Leadframe Package (LLP)* (SNOA401) and the *WSON Mounting* section in this datasheet. If power dissipation causes the junction temperature to exceed specified limits, the device goes into thermal shutdown.

6.2 ESD Ratings

	VALUE	UNIT
V _(ESD) Electrostatic discharge Human-body model (HBM), per ANSI/ESDA/JEDEC JS-001 ⁽¹⁾	±2000	V

- (1) JEDEC document JEP155 states that 500-V HBM allows safe manufacturing with a standard ESD control process.

6.3 Recommended Operating Conditions

over operating free-air temperature range (unless otherwise noted)

	MIN	NOM	MAX	UNIT
V _{IN} supply voltage	2.7		10	V
Operating junction temperature	-40		125	°C

6.4 Thermal Information

THERMAL METRIC ⁽¹⁾	LP38690 TO-252 3 PINS	LP38690/92 WSON 6 PINS	LP38692 SOT-223 5 PINS	UNIT
R _{θJA} ⁽²⁾ Junction-to-ambient thermal resistance	50.5	50.6	68.5	°C/W
R _{θJC(top)} Junction-to-case (top) thermal resistance	52.6	44.4	52.2	°C/W
R _{θJB} Junction-to-board thermal resistance	29.7	24.9	13.0	°C/W
ψ _{JT} Junction-to-top characterization parameter	4.8	0.4	5.5	°C/W
ψ _{JB} Junction-to-board characterization parameter	29.3	25.1	12.8	°C/W
R _{θJC(bot)} Junction-to-case (bottom) thermal resistance	1.5	5.4	n/a	°C/W

- (1) For more information about traditional and new thermal metrics, see the *Semiconductor and IC Package Thermal Metrics* application report, [SPRA953](#).
- (2) Junction-to-ambient thermal resistance, High-K.

6.5 Electrical Characteristics

Unless otherwise specified: $V_{IN} = V_{OUT} + 1\text{ V}$, $C_{IN} = C_{OUT} = 10\text{ }\mu\text{F}$, $I_{LOAD} = 10\text{ mA}$, and limits are for $T_J = 25^\circ\text{C}$. Minimum (MIN) and maximum (MAX) limits are specified through testing, statistical correlation, or design.

PARAMETER		TEST CONDITIONS	MIN	TYP ⁽¹⁾	MAX	UNIT	
V_{OUT}	Output voltage tolerance		-2.5		2.5	% V_{OUT}	
		$100\text{ }\mu\text{A} < I_L < 1\text{ A}$ $V_O + 1\text{ V} \leq V_{IN} \leq 10\text{ V}$ $-40^\circ\text{C} \leq T_J \leq 125^\circ\text{C}$	-5		5		
$\Delta V_{OUT}/\Delta V_{IN}$	Output voltage line regulation ⁽²⁾	$V_{OUT} + 0.5\text{ V} \leq V_{IN} \leq 10\text{ V}$ $I_L = 25\text{ mA}$		0.03		%/ A	
		$V_{OUT} + 0.5\text{ V} \leq V_{IN} \leq 10\text{ V}$ $I_L = 25\text{ mA}$ $-40^\circ\text{C} \leq T_J \leq 125^\circ\text{C}$			1		
$\Delta V_{OUT}/\Delta I_L$	Output voltage load regulation ⁽³⁾	$1\text{ mA} < I_L < 1\text{ A}$ $V_{IN} = V_{OUT} + 1\text{ V}$		1.8		V	
		$1\text{ mA} < I_L < 1\text{ A}$ $V_{IN} = V_{OUT} + 1\text{ V}$ $-40^\circ\text{C} \leq T_J \leq 125^\circ\text{C}$			5		
$V_{IN} - V_{OUT}$	Dropout voltage ⁽⁴⁾	$V_{OUT} = 1.8\text{ V}$ $I_L = 1\text{ A}$		950		mV	
		$V_{OUT} = 1.8\text{ V}$ $I_L = 1\text{ A}$ $-40^\circ\text{C} \leq T_J \leq 125^\circ\text{C}$			1600		
		$V_{OUT} = 2.5\text{ V}$	$I_L = 0.1\text{ A}$		80		
			$I_L = 1\text{ A}$		800		
		$V_{OUT} = 2.5\text{ V}$ $-40^\circ\text{C} \leq T_J \leq 125^\circ\text{C}$	$I_L = 0.1\text{ A}$		145		
			$I_L = 1\text{ A}$		1300		
		$V_{OUT} = 3.3\text{ V}$	$I_L = 0.1\text{ A}$		65		
			$I_L = 1\text{ A}$		650		
		$V_{OUT} = 3.3\text{ V}$ $-40^\circ\text{C} \leq T_J \leq 125^\circ\text{C}$	$I_L = 0.1\text{ A}$		110		
			$I_L = 1\text{ A}$		1000		
$V_{OUT} = 5\text{ V}$	$I_L = 0.1\text{ A}$		45				
	$I_L = 1\text{ A}$		450				
$V_{OUT} = 5\text{ V}$, $-40^\circ\text{C} \leq T_J \leq 125^\circ\text{C}$	$I_L = 0.1\text{ A}$		100				
	$I_L = 1\text{ A}$		800				
I_Q	Quiescent current	$V_{IN} \leq 10\text{ V}$, $I_L = 100\text{ }\mu\text{A}$ to 1 A		55		μA	
		$V_{IN} \leq 10\text{ V}$, $I_L = 100\text{ }\mu\text{A}$ to 1 A $-40^\circ\text{C} \leq T_J \leq 125^\circ\text{C}$			100		
		$V_{EN} \leq 0.4\text{ V}$ (LP38692 only)		0.001			
$I_L(\text{MIN})$	Minimum load current	$V_{IN} - V_{OUT} \leq 4\text{ V}$ $-40^\circ\text{C} \leq T_J \leq 125^\circ\text{C}$			100		
I_{FB}	Foldback current limit	$V_{IN} - V_{OUT} > 5\text{ V}$		450		mA	
		$V_{IN} - V_{OUT} < 4\text{ V}$		1500			
PSRR	Ripple rejection	$V_{IN} = V_{OUT} + 2\text{ V}_{(DC)}$, with $1\text{ V}_{(p-p)} / 120\text{ Hz}$ ripple		55		dB	
T_{SD}	Thermal shutdown activation (junction temp)			160		$^\circ\text{C}$	
$T_{SD}(\text{HYST})$	Thermal shutdown hysteresis (junction temp)			10			
e_n	Output noise	$V_{OUT} = 3.3\text{ V}$, BW = 10 Hz to 10 kHz		0.7		$\mu\text{V}/\sqrt{\text{Hz}}$	
$V_{OUT}(\text{LEAK})$	Output leakage current	$V_{OUT} = V_{OUT(\text{NOM})} + 1\text{ V}$ at 10 V_{IN}		0.5	12	μA	

(1) Typical numbers represent the most likely parametric norm for 25°C operation.

(2) Output voltage line regulation is defined as the change in output voltage from nominal value resulting from a change in input voltage.

(3) Output voltage load regulation is defined as the change in output voltage from nominal value as the load current increases from 1 mA to full load.

(4) Dropout voltage is defined as the minimum input to output differential required to maintain the output within 100 mV of nominal value.

Electrical Characteristics (continued)

Unless otherwise specified: $V_{IN} = V_{OUT} + 1\text{ V}$, $C_{IN} = C_{OUT} = 10\ \mu\text{F}$, $I_{LOAD} = 10\ \text{mA}$, and limits are for $T_J = 25^\circ\text{C}$. Minimum (MIN) and maximum (MAX) limits are specified through testing, statistical correlation, or design.

PARAMETER	TEST CONDITIONS	MIN	TYP ⁽¹⁾	MAX	UNIT
V_{EN}	Output = OFF, $-40^\circ\text{C} \leq T_J \leq 125^\circ\text{C}$			0.4	V
	Output = ON, $V_{IN} = 4\text{ V}$ $-40^\circ\text{C} \leq T_J \leq 125^\circ\text{C}$	1.8			
	Output = ON, $V_{IN} = 6\text{ V}$ $-40^\circ\text{C} \leq T_J \leq 125^\circ\text{C}$	3			
	Output = ON, $V_{IN} = 10\text{ V}$ $-40^\circ\text{C} \leq T_J \leq 125^\circ\text{C}$	4			
I_{EN}	Enable pin leakage $V_{EN} = 0\text{ V}$ or 10 V , $V_{IN} = 10\text{ V}$	-1	0.001	1	μA

6.6 Typical Characteristics

Unless otherwise specified: $T_J = 25^\circ\text{C}$, $C_{IN} = C_{OUT} = 10\ \mu\text{F}$, EN pin is tied to V_{IN} (LP38692 only), $V_{OUT} = 1.8\text{ V}$, $V_{IN} = V_{OUT} + 1\text{ V}$, $I_L = 10\ \text{mA}$.

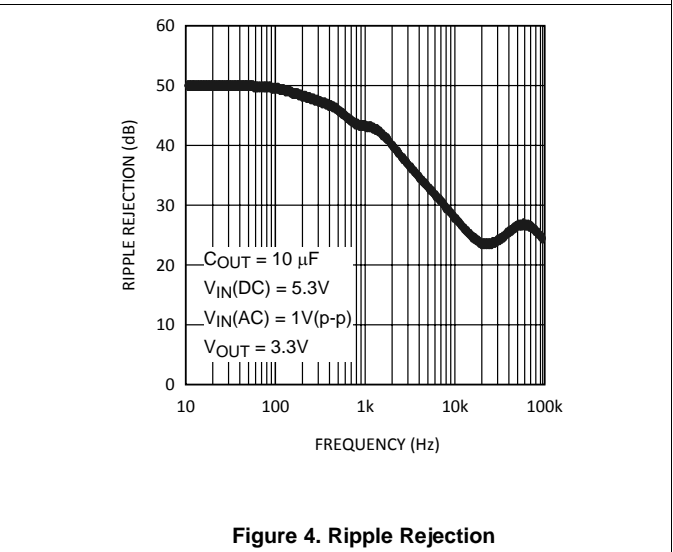
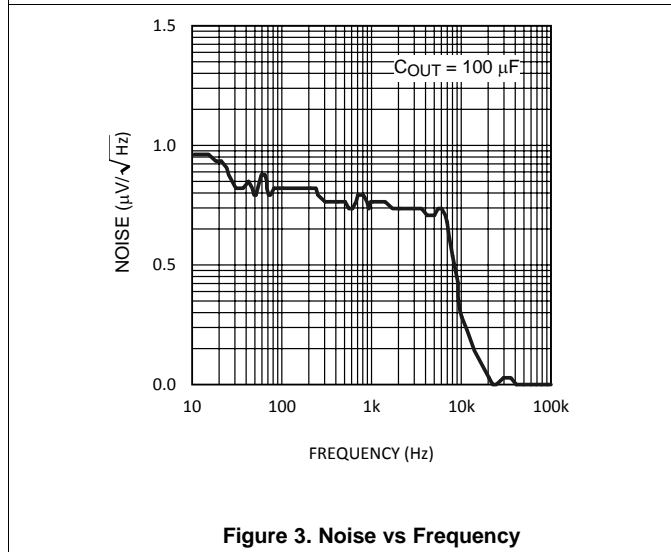
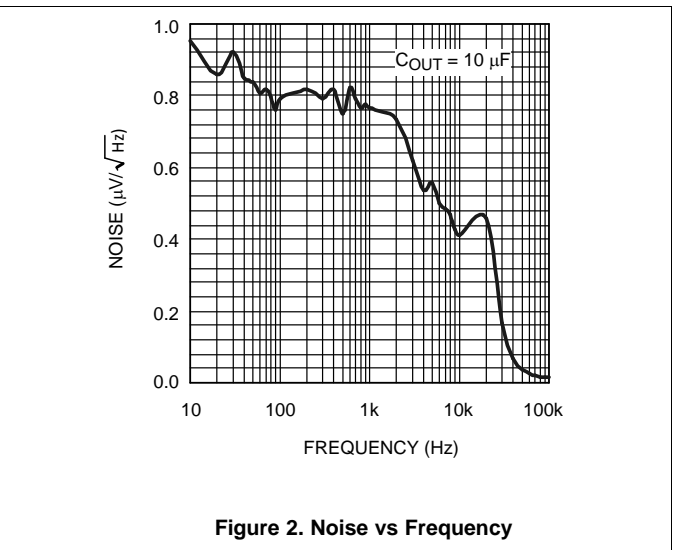
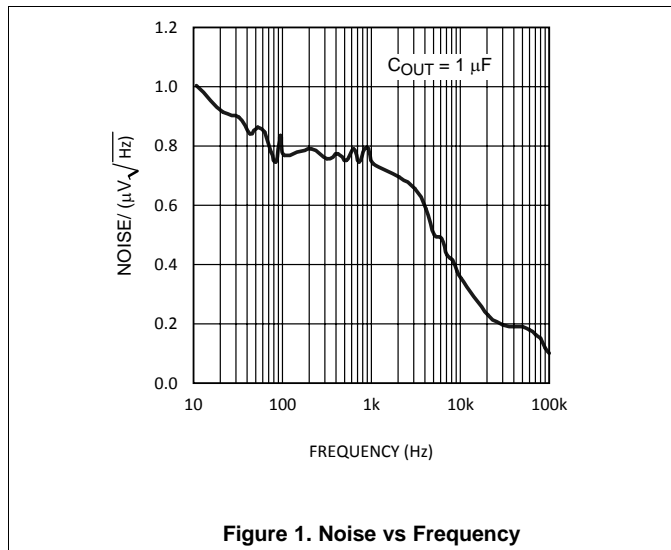

Typical Characteristics (continued)

Unless otherwise specified: $T_J = 25^\circ\text{C}$, $C_{IN} = C_{OUT} = 10\ \mu\text{F}$, EN pin is tied to V_{IN} (LP38692 only), $V_{OUT} = 1.8\ \text{V}$, $V_{IN} = V_{OUT} + 1\ \text{V}$, $I_L = 10\ \text{mA}$.

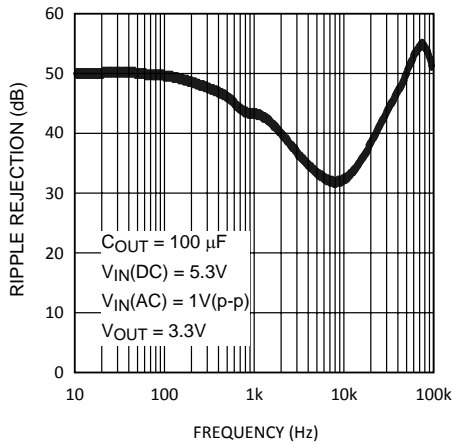

Figure 5. Ripple Rejection

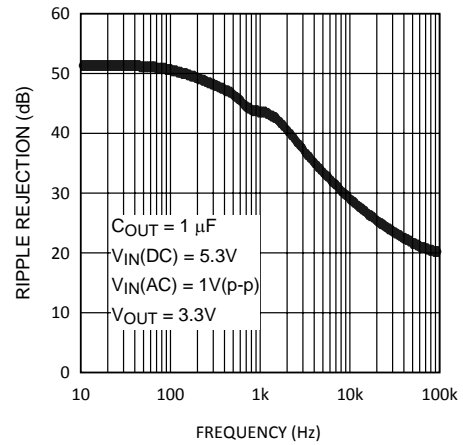

Figure 6. Ripple Rejection

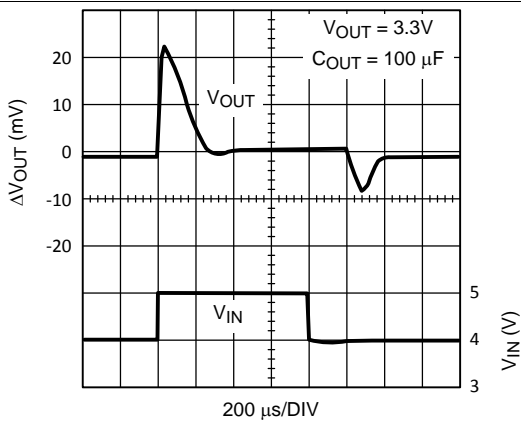

Figure 7. Line Transient Response

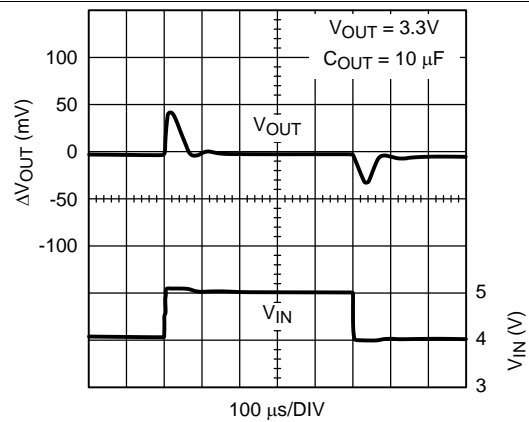

Figure 8. Line Transient Response

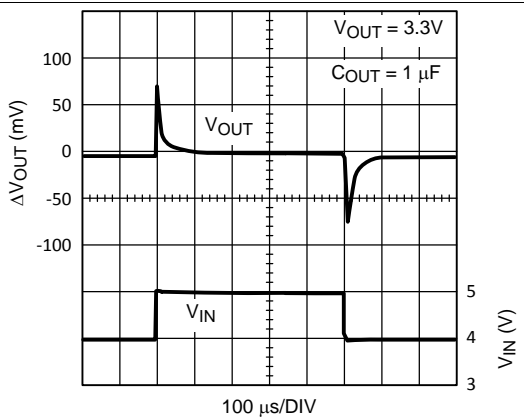

Figure 9. Line Transient Response

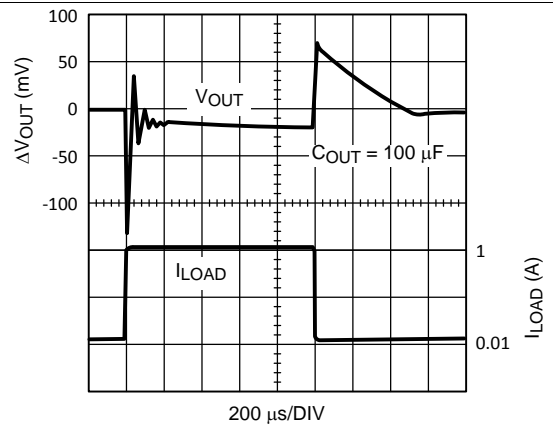

Figure 10. Load Transient Response

Typical Characteristics (continued)

Unless otherwise specified: $T_J = 25^\circ\text{C}$, $C_{IN} = C_{OUT} = 10\ \mu\text{F}$, EN pin is tied to V_{IN} (LP38692 only), $V_{OUT} = 1.8\ \text{V}$, $V_{IN} = V_{OUT} + 1\ \text{V}$, $I_L = 10\ \text{mA}$.

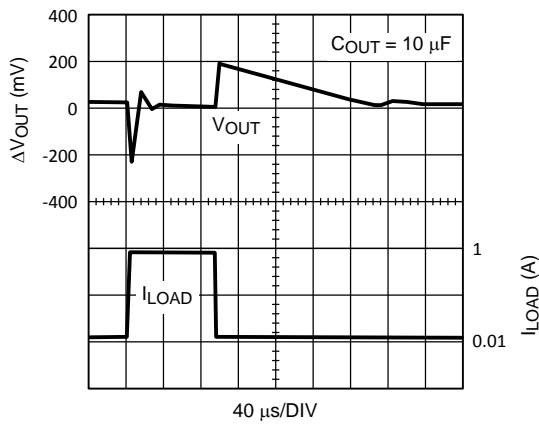

Figure 11. Load Transient Response

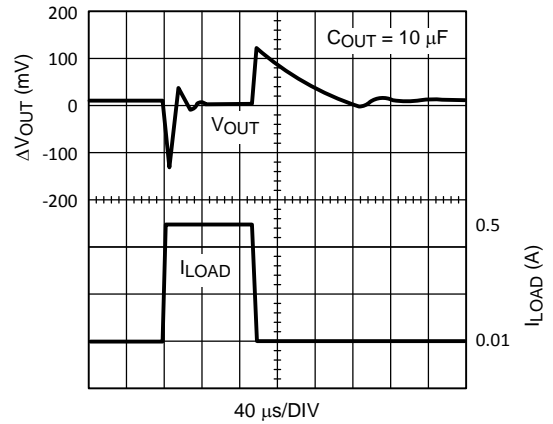

Figure 12. Load Transient Response

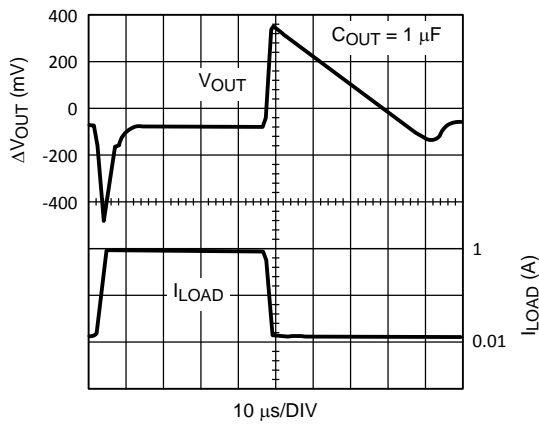

Figure 13. Load Transient Response

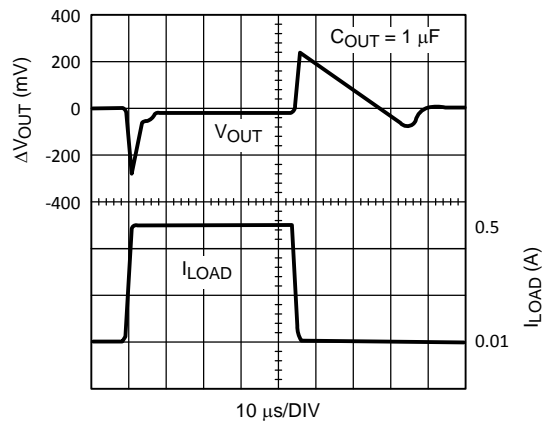

Figure 14. Load Transient Response

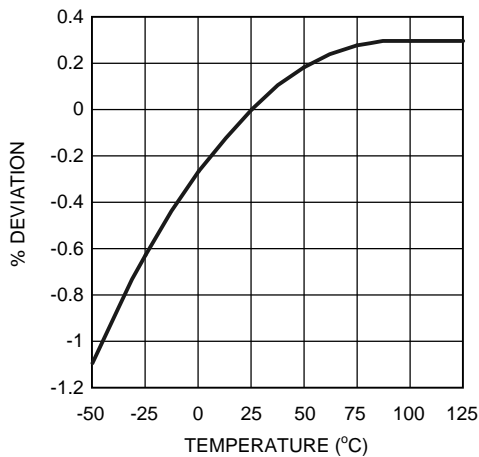

Figure 15. V_{OUT} vs Temperature (5 V)

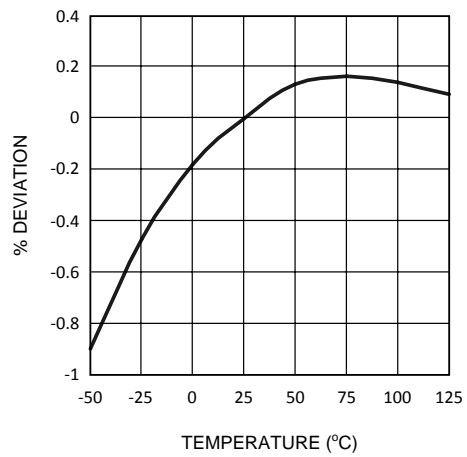

Figure 16. V_{OUT} vs Temperature (3.3 V)

Typical Characteristics (continued)

Unless otherwise specified: $T_J = 25^\circ\text{C}$, $C_{IN} = C_{OUT} = 10\ \mu\text{F}$, EN pin is tied to V_{IN} (LP38692 only), $V_{OUT} = 1.8\ \text{V}$, $V_{IN} = V_{OUT} + 1\ \text{V}$, $I_L = 10\ \text{mA}$.

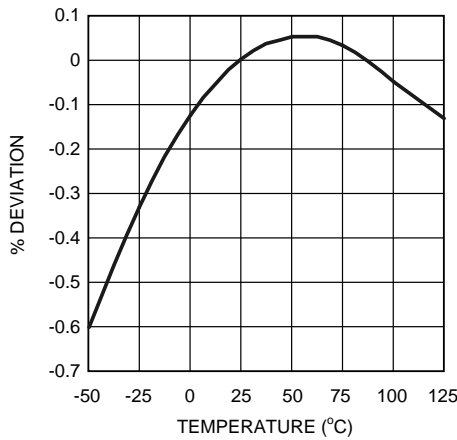

Figure 17. V_{OUT} vs Temperature (2.5 V)

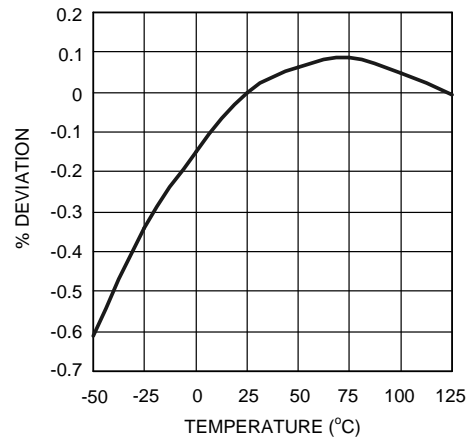

Figure 18. V_{OUT} vs Temperature (1.8 V)

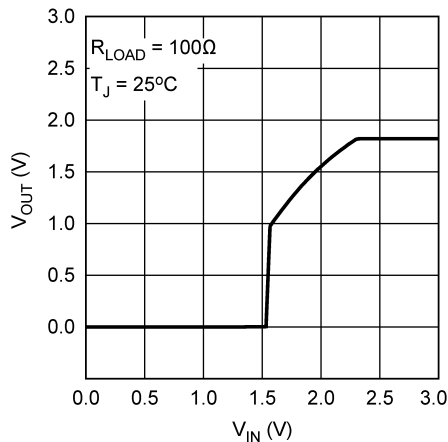

Figure 19. V_{OUT} vs V_{IN} (1.8 V)

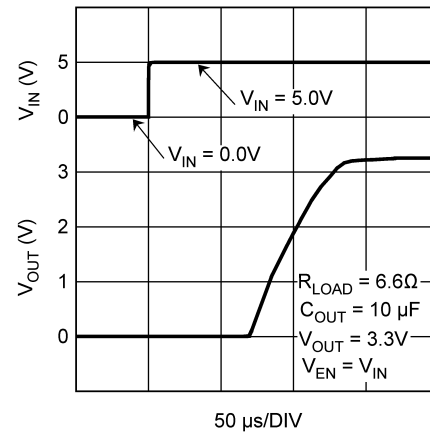

Figure 20. V_{OUT} vs V_{IN} (Power-Up)

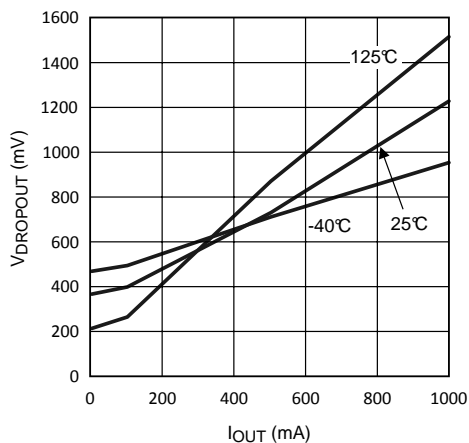

Figure 21. Dropout Voltage vs I_{OUT}

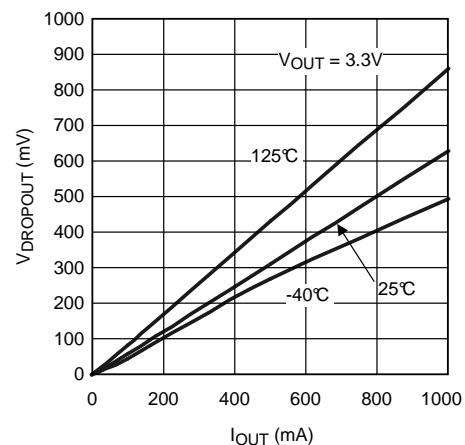
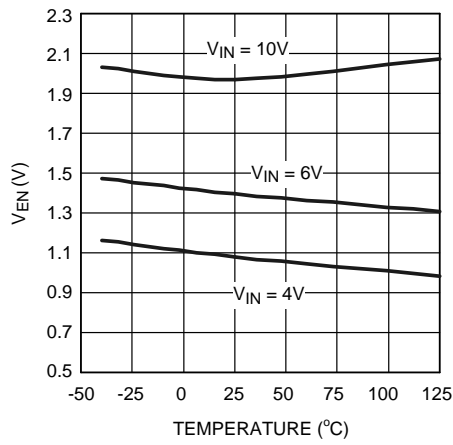
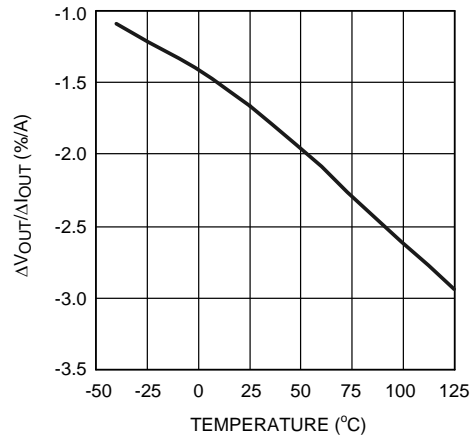
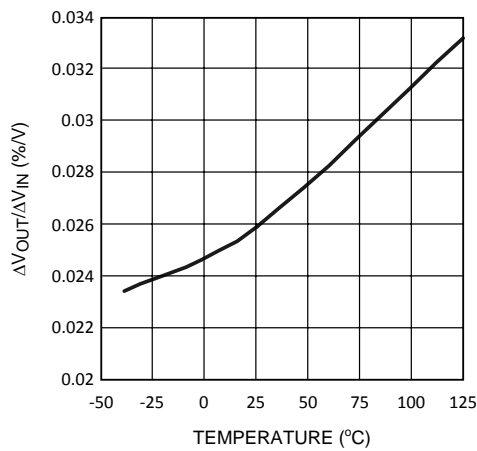

Figure 22. Dropout Voltage vs I_{OUT}

Typical Characteristics (continued)

Unless otherwise specified: $T_J = 25^\circ\text{C}$, $C_{IN} = C_{OUT} = 10\ \mu\text{F}$, EN pin is tied to V_{IN} (LP38692 only), $V_{OUT} = 1.8\ \text{V}$, $V_{IN} = V_{OUT} + 1\ \text{V}$, $I_L = 10\ \text{mA}$.

Figure 23. Enable Voltage vs Temperature

Figure 24. Load Regulation vs Temperature

Figure 25. Line Regulation vs Temperature

7 Detailed Description

7.1 Overview

The LP38690 and LP38692 devices are designed to meet the requirements of portable, battery-powered digital systems providing an accurate output voltage with fast start-up. When disabled via a low logic signal at the enable pin (EN), the power consumption is reduced to virtually zero (LP38692 only). The LP38690 and LP38692 perform well with a single 1- μ F input capacitor and a single 1- μ F ceramic output capacitor.

7.2 Functional Block Diagrams

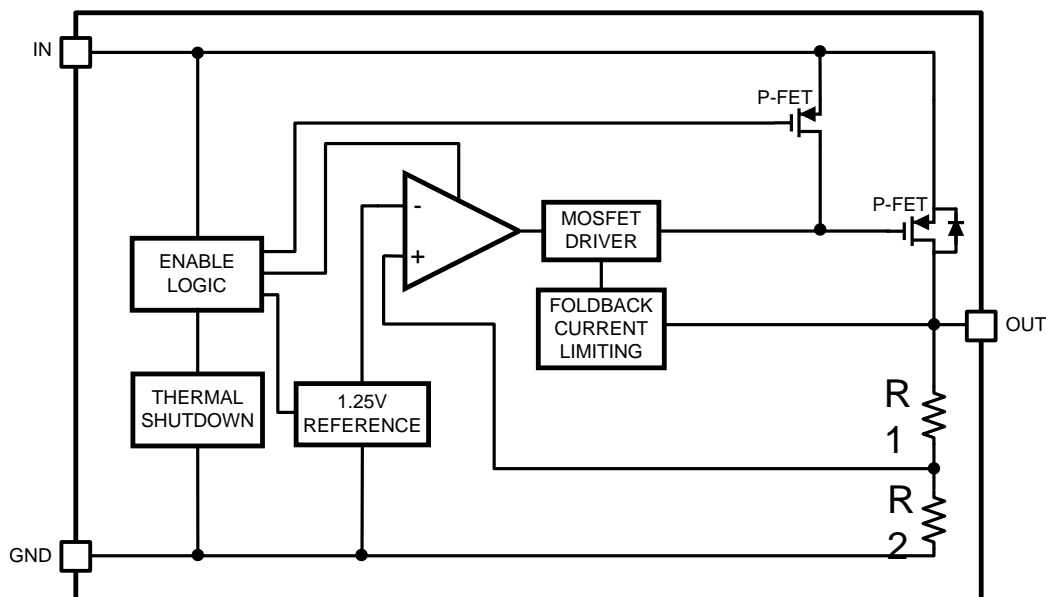

Figure 26. LP38690 Functional Diagram (TO-252)

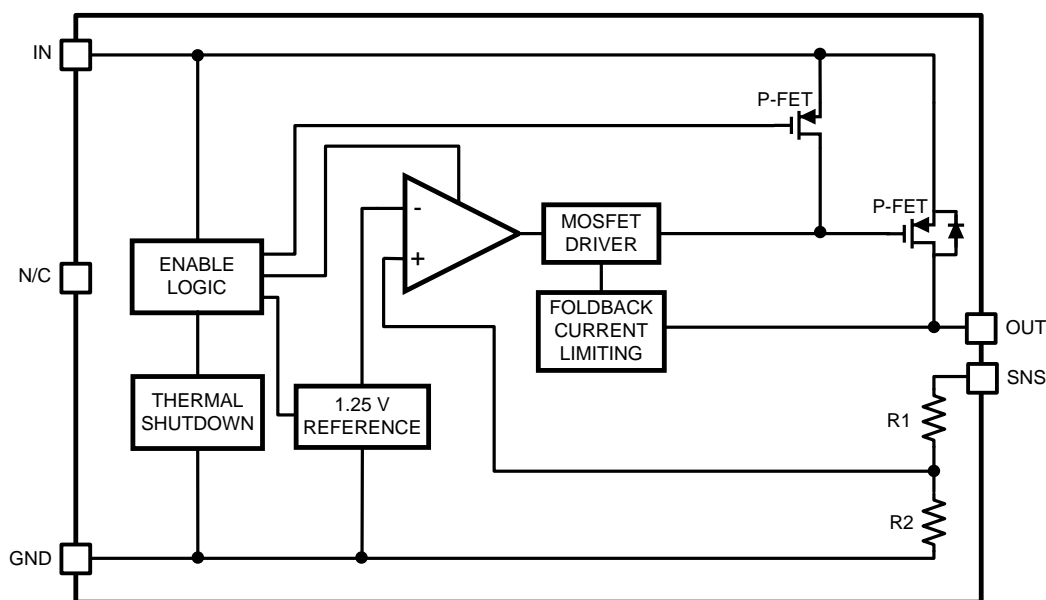

Figure 27. LP38690 Functional Diagram (WSON)

Functional Block Diagrams (continued)

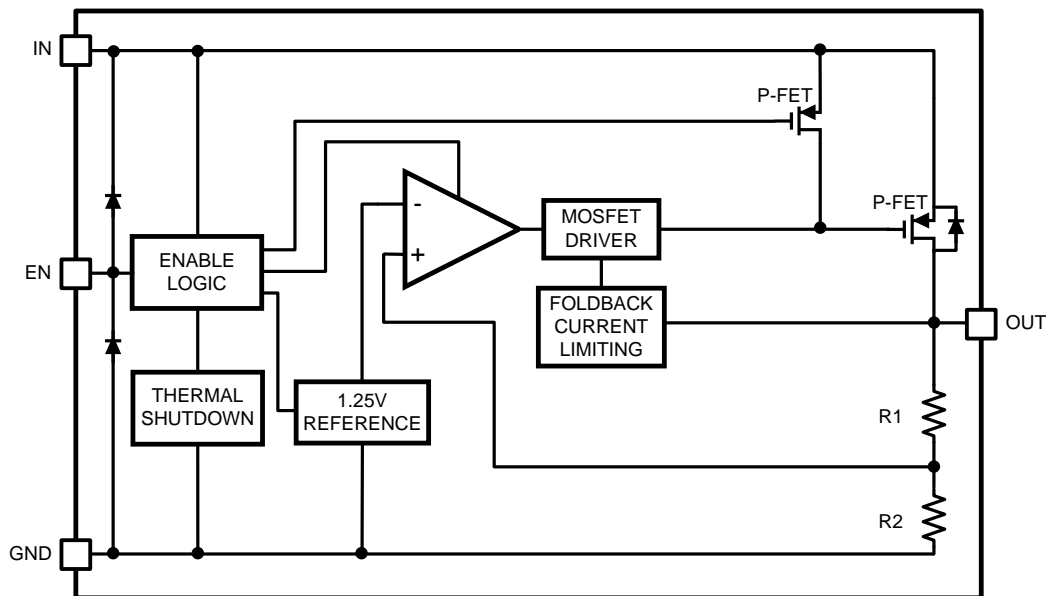

Figure 28. LP38692 Functional Diagram (SOT-223)

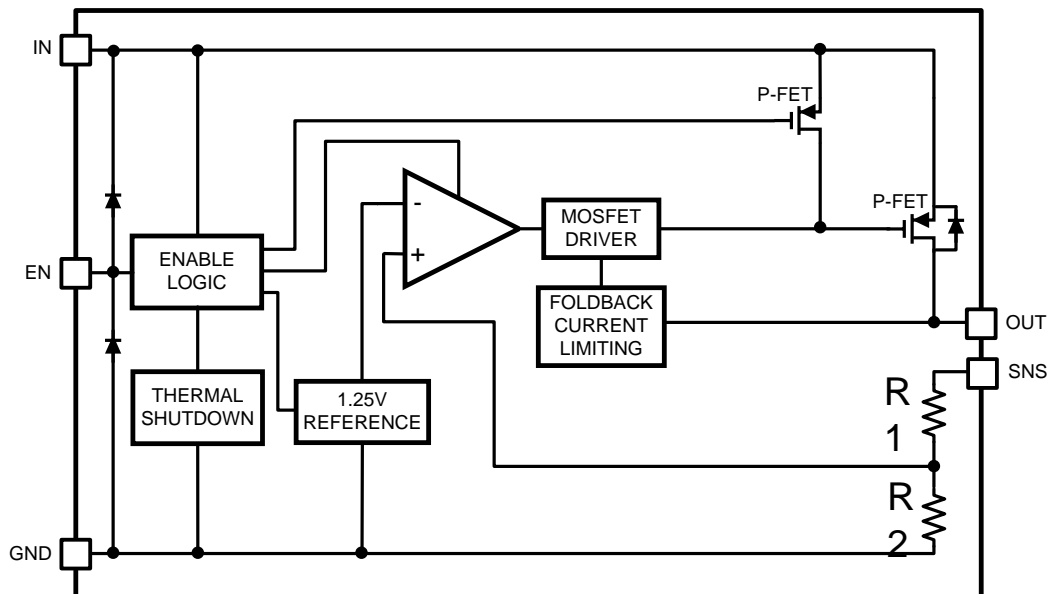

Figure 29. LP38692 Functional Diagram (WSON)

7.3 Feature Description

7.3.1 Enable (EN)

The LP38692 has an Enable pin (EN) which allows an external control signal to turn the regulator output On and Off. The Enable On/Off threshold has no hysteresis. The voltage signal must rise and fall cleanly, and promptly, through the ON and OFF voltage thresholds. The EN pin voltage must be higher than the $V_{EN(MIN)}$ threshold to ensure that the device is fully enabled under all operating conditions. The EN pin voltage must be lower than the $V_{EN(MAX)}$ threshold to ensure that the device is fully disabled. The Enable pin has no internal pull-up or pull-down to establish a default condition and, as a result, this pin must be terminated either actively or passively. If the Enable pin is driven from a source that actively pulls high and low, the drive voltage should not be allowed to go below ground potential or higher than V_{IN} . If the application does not require the Enable function, the pin should be connected directly to the IN pin.

7.3.2 Thermal Shutdown Protection (TSD)

Thermal shutdown disables the output when the junction temperature rises to approximately 160°C which allows the device to cool. When the junction temperature cools to approximately 150°C, the output circuitry enables.

Based on power dissipation, thermal resistance, and ambient temperature, the thermal protection circuit may cycle on and off. This thermal cycling limits the dissipation of the regulator and protects it from damage as a result of overheating.

The TSD circuitry of the LP38692 has been designed to protect against temporary thermal overload conditions. The TSD circuitry was not intended to replace proper heat-sinking. Continuously running the LP38692 device into thermal shutdown degrades device reliability.

7.3.3 Foldback Current Limiting

Foldback current limiting is built into the LP38690 and LP38692 which reduces the amount of output current the part can deliver as the output voltage is reduced. The amount of load current is dependent on the differential voltage between V_{IN} and V_{OUT} . Typically, when this differential voltage exceeds 5 V, the load current limits at about 450 mA. When the $V_{IN} - V_{OUT}$ differential is reduced below 4 V, load current is limited to about 1500 mA.

CAUTION

When toggling the LP38692 Enable (EN) after the input voltage (V_{IN}) is applied, the foldback current limit circuitry is functional the first time that the EN pin is taken high. The foldback current limit circuitry is non-functional the second, and subsequent, times that the EN pin is taken high. Depending on the input and output capacitance values the input inrush current may be higher than expected which can cause the input voltage to droop.

If the EN pin is connected to the IN pin, the foldback current limit circuitry is functional when V_{IN} is applied if V_{IN} starts from less than 0.4 V.

7.4 Device Functional Modes

7.4.1 Enable (EN)

The EN pin voltage must be higher than the $V_{EN(MIN)}$ threshold to ensure that the device is fully enabled under all operating conditions.

7.4.2 Minimum Operating Input Voltage (V_{IN})

The LP38690 and LP38692 devices do not include any dedicated UVLO circuitry. The LP38690 and LP38692 internal circuitry is not fully functional until V_{IN} is at least 2.7 V. The output voltage is not regulated until $V_{IN} \geq (V_{OUT} + V_{DO})$, or 2.7 V, whichever is higher.

8 Application and Implementation

NOTE

Information in the following applications sections is not part of the TI component specification, and TI does not warrant its accuracy or completeness. TI's customers are responsible for determining suitability of components for their purposes. Customers should validate and test their design implementation to confirm system functionality.

8.1 Application Information

8.1.1 Reverse Voltage

A reverse voltage condition exists when the voltage at the output pin is higher than the voltage at the input pin. Typically this happens when V_{IN} is abruptly taken low and C_{OUT} continues to hold a sufficient charge such that the input to output voltage becomes reversed. A less common condition is when an alternate voltage source is connected to the output.

There are two possible paths for current to flow from the output pin back to the input during a reverse voltage condition.

1. While V_{IN} is high enough to keep the control circuitry alive, and the EN pin (LP38692 only) is above the $V_{EN(ON)}$ threshold, the control circuitry attempts to regulate the output voltage. If the input voltage is less than the programmed output voltage, the control circuit drives the gate of the pass element to the full ON condition. In this condition, reverse current flows from the output pin to the input pin, limited only by the $R_{DS(ON)}$ of the pass element and the output to input voltage differential. Discharging an output capacitor up to 1000 μ F in this manner does not damage the device as the current will rapidly decay. However, continuous reverse current should be avoided. When the EN pin is low this condition is prevented.
2. The internal PFET pass element has an inherent parasitic diode. During normal operation, the input voltage is higher than the output voltage and the parasitic diode is reverse biased. However, when V_{IN} is below the value where the control circuitry is alive, or the EN pin is low (LP38692 only), and the output voltage is more than 500 mV (typical) above the input voltage the parasitic diode becomes forward biased and current flows from the output pin to the input pin through the diode. The current in the parasitic diode should be limited to less than 1 A continuous and 5 A peak.

If used in a dual-supply system where the regulator output load is returned to a negative supply, the output pin must be diode clamped to ground to limit the negative voltage transition. A Schottky diode is recommended for this protective clamp.

8.2 Typical Applications

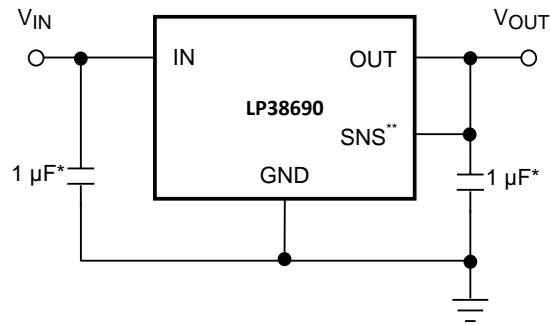

* Minimum value required for stability.

**WSON package devices only.

Figure 30. LP38690 Typical Application

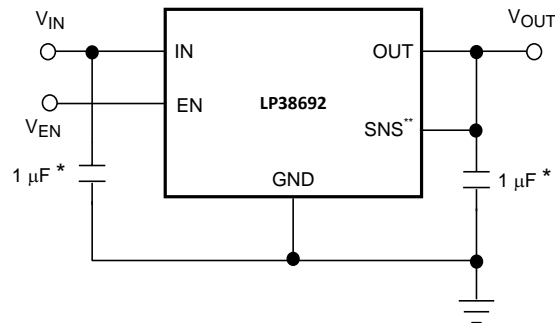

* Minimum value required for stability.

**WSON package devices only.

Figure 31. LP38692 Typical Application

8.2.1 Design Requirements

For typical CMOS voltage regulator applications, use the parameters listed in [Table 1](#).

Table 1. Design Parameters

DESIGN PARAMETER	EXAMPLE VALUE
Input voltage range	2.7 to 10 V
Output voltage	1.8 V
Output current	1 A
Output capacitor range	1 µF
Input/output capacitor ESR range	5 mΩ to 500 mΩ

8.2.2 Detailed Design Procedure

8.2.2.1 Power Dissipation and Device Operation

The permissible power dissipation for any package is a measure of the capability of the device to pass heat from the power source, the junctions of the device, to the ultimate heat sink, the ambient environment. Thus, the power dissipation is dependent on the ambient temperature and the thermal resistance across the various interfaces between the die junction and ambient air.

The permissible power dissipation for any package is a measure of the capability of the device to pass heat from the power source, the junctions of the device, to the ultimate heat sink, the ambient environment. Thus, the power dissipation is dependent on the ambient temperature and the thermal resistance across the various interfaces between the die junction and ambient air.

The maximum allowable power dissipation for the device in a given package can be calculated using [Equation 1](#):

$$P_{D-MAX} = ((T_{J-MAX} - T_A) / R_{\theta JA}) \quad (1)$$

The actual power being dissipated in the device can be represented by [Equation 2](#):

$$P_D = (V_{IN} - V_{OUT}) \times I_{OUT} \quad (2)$$

These two equations establish the relationship between the maximum power dissipation allowed due to thermal consideration, the voltage drop across the device, and the continuous current capability of the device. These two equations should be used to determine the optimum operating conditions for the device in the application.

In applications where lower power dissipation (P_D) and/or excellent package thermal resistance ($R_{\theta JA}$) is present, the maximum ambient temperature (T_{A-MAX}) may be increased.

In applications where high power dissipation and/or poor package thermal resistance is present, the maximum ambient temperature (T_{A-MAX}) may have to be derated. T_{A-MAX} is dependent on the maximum operating junction temperature ($T_{J-MAX-OP} = 125^\circ\text{C}$), the maximum allowable power dissipation in the device package in the application (P_{D-MAX}), and the junction-to ambient thermal resistance of the part/package in the application ($R_{\theta JA}$), as given by [Equation 3](#):

$$T_{A-MAX} = (T_{J-MAX-OP} - (R_{\theta JA} \times P_{D-MAX})) \quad (3)$$

Alternately, if T_{A-MAX} can not be derated, the P_D value must be reduced. This can be accomplished by reducing V_{IN} in the $V_{IN} - V_{OUT}$ term as long as the minimum V_{IN} is met, or by reducing the I_{OUT} term, or by some combination of the two.

8.2.2.2 External Capacitors

In common with most regulators, the LP38690 and LP38692 require external capacitors for regulator stability. The LP38690 and LP38692 are specifically designed for portable applications requiring minimum board space and smallest components. These capacitors must be correctly selected for good performance.

8.2.2.2.1 Input Capacitor

An input capacitor is required for stability. It is recommended that a 1- μF capacitor be connected between the LP38690 or LP38692 IN pin and GND pin (this capacitance value may be increased without limit). This capacitor must be located a distance of not more than 1 cm from the IN pin and returned to a clean analogue ground. Any good quality ceramic, tantalum, or film capacitor may be used at the input.

Important: To ensure stable operation it is essential that good PCB design practices are employed to minimize ground impedance and keep input inductance low. If these conditions cannot be met, or if long leads are used to connect the battery or other power source to the LP38690 or LP38692, then it is recommended that the input capacitor is increased. Also, tantalum capacitors can suffer catastrophic failures due to surge current when connected to a low-impedance source of power (like a battery or a very large capacitor). If a tantalum capacitor is used at the input, it must be ensured by the manufacturer to have a surge current rating sufficient for the application.

There are no requirements for the equivalent series resistance (ESR) on the input capacitor, but tolerance and temperature coefficient must be considered when selecting the capacitor to ensure the capacitance remains approximately 1 μF over the entire operating temperature range.

8.2.2.2.2 Output Capacitor

The LP38690 and LP38692 are designed specifically to work with very small ceramic output capacitors. A 1- μ F ceramic capacitor (temperature types Z5U, Y5V or X7R/X5R) with ESR between 5 m Ω to 500 m Ω , is suitable in the LP38690 or LP38692 application circuit.

For this device the output capacitor should be connected between the OUT pin and GND pin. It is also possible to use tantalum or film capacitors at the device output, but these are not as attractive for reasons of size and cost (see [Capacitor Characteristics](#)). The output capacitor must meet the requirement for the minimum value of capacitance and also have an ESR value that is within the range 5 m Ω to 500 m Ω for stability.

8.2.2.2.3 No Load Stability

The LP38690 and LP38692 remain stable and in regulation with no external load. This is an important consideration in some circuits, for example CMOS RAM keep-alive applications.

8.2.2.2.4 Capacitor Characteristics

The LP38690 and LP38692 are designed to work with ceramic capacitors on the output to take advantage of the benefits they offer. For capacitance values in the range of 0.47 μ F to 4.7 μ F, ceramic capacitors are the smallest, least expensive and have the lowest ESR values, thus making them best for eliminating high frequency noise. The ESR of a typical 1- μ F ceramic capacitor is in the range of 20 m Ω to 40 m Ω , which easily meets the ESR requirement for stability for the LP38690 or LP38692.

For both input and output capacitors, careful interpretation of the capacitor specification is required to ensure correct device operation. The capacitor value can change greatly, depending on the operating conditions and capacitor type.

In particular, the output capacitor selection should take account of all the capacitor parameters, to ensure that the specification is met within the application. The capacitance can vary with DC bias conditions as well as temperature and frequency of operation. Capacitor values also shows some decrease over time due to aging. The capacitor parameters are also dependent on the particular case size, with smaller sizes giving poorer performance figures in general. As an example, [Figure 32](#) shows a typical graph comparing different capacitor case sizes in a capacitance vs DC bias plot. As shown in [Figure 32](#), increasing the DC Bias condition can result in the capacitance value falling below the minimum value given in the recommended capacitor specifications table (0.7 μ F in this case). Note that the graph shows the capacitance out of spec for the 0402 case size capacitor at higher bias voltages. It is therefore recommended that the capacitor manufacturers' specifications for the nominal value capacitor are consulted for all conditions, as some capacitor sizes (for example, 0402) may not be suitable in the actual application.

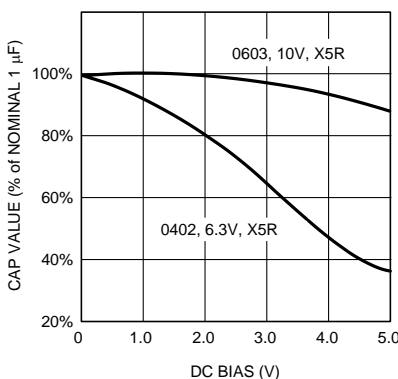
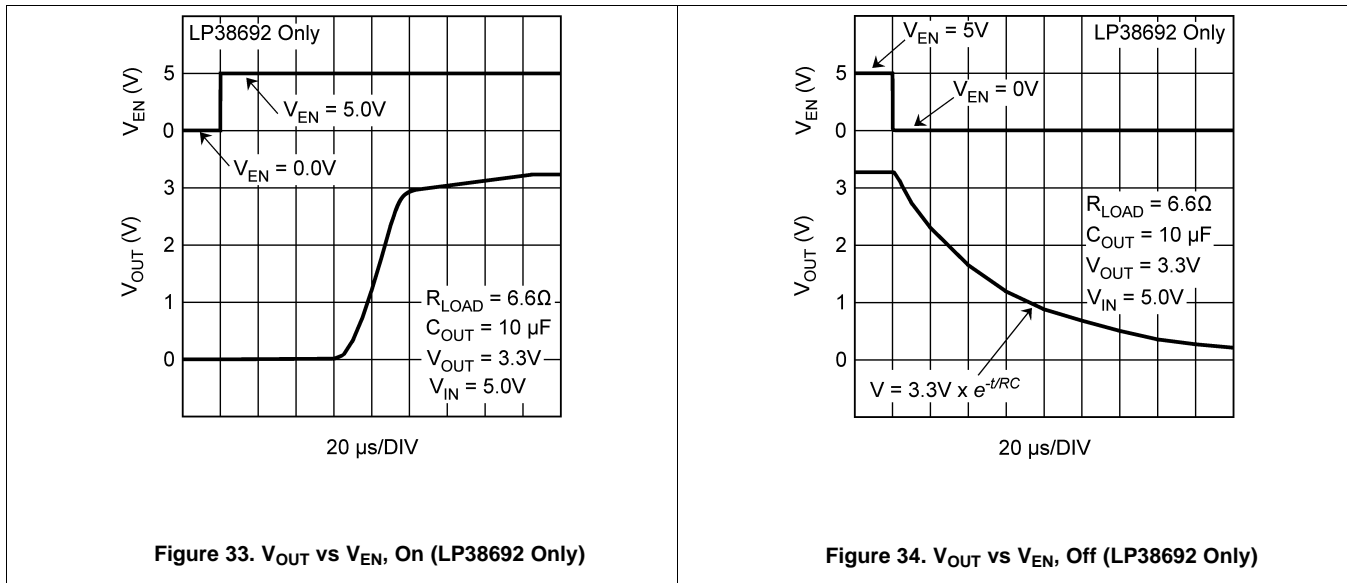

Figure 32. Typical Variation In Capacitance vs DC Bias

The ceramic capacitor's value varies with temperature. The capacitor type X7R, which operates over a temperature range of -55°C to 125°C, only varies the capacitance to within \pm 15%. The capacitor type X5R has a similar tolerance over a reduced temperature range of -55°C to 85°C. Many large value ceramic capacitors, larger than 1 μ F are manufactured with Z5U or Y5V temperature characteristics. Their capacitance can drop by more than 50% as the temperature varies from 25°C to 85°C. Therefore, X7R and X5R types are recommended over Z5U and Y5V in applications where the ambient temperature changes significantly above or below 25°C.

Tantalum capacitors are less desirable than ceramic for use as output capacitors because they are more costly when comparing equivalent capacitance and voltage ratings in the 0.47- μF to 4.7- μF range. Another important consideration is that tantalum capacitors have higher ESR values than equivalent size ceramic capacitors. This means that while it may be possible to find a tantalum capacitor with an ESR value within the stable range, it would have to be larger in capacitance (which means bigger and more costly) than a ceramic capacitor with the same ESR value. It should also be noted that the ESR of a typical tantalum increases about 2:1 as the temperature goes from 25°C down to -40°C, so some guard band must be allowed.

8.2.3 Application Curves



9 Power Supply Recommendations

The LP38690 and LP38692 are designed to operate from an input supply voltage range of 2.7 V to 10 V. The input supply must be well regulated and free of spurious noise. To ensure that the LP38690 or LP38692 output voltage is well regulated, the input supply must be at least $V_{OUT} + 0.5 \text{ V}$, or 2.7 V, whichever is higher. A minimum capacitor value of 1- μF is required to be within 1 cm of the IN pin.

10 Layout

10.1 PCB Layout

The dynamic performance of the LP38690 and LP38692 devices is dependent on the layout of the PCB. PCB layout practices that are adequate for typical LDOs may degrade the load regulation, PSRR, noise, or transient performance of the LP38690 or LP38692.

Best performance is achieved by placing C_{IN} and C_{OUT} on the same side of the PCB as the LP38690 or LP38692, and as close to the package as is practical. The ground connections for C_{IN} and C_{OUT} must be back to the LP38690 or LP38692 GND pin using as wide and short a copper trace as is practical.

Connections using long trace lengths, narrow trace widths, or connections through vias must be avoided. These add parasitic inductances and resistance that result in inferior performance especially during transient conditions.

A ground plane, either on the opposite side of a two-layer PCB, or embedded in a multi-layer PCB, is strongly recommended. This ground plane serves two purposes:

1. Provides a circuit reference plane to assure accuracy, and
2. provides a thermal plane to remove heat from the LP38690 or LP38692 WSON package through thermal vias under the package DAP.

10.2 Layout Examples

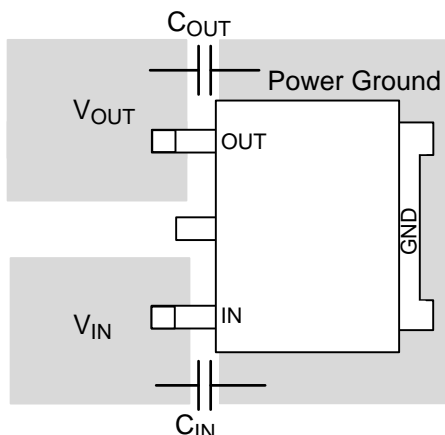

Figure 35. LP38690 TO-252 Package

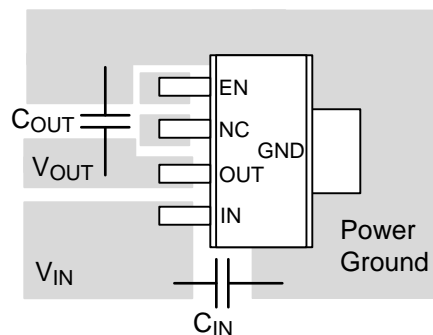

Figure 36. LP38692 SOT-223 Package

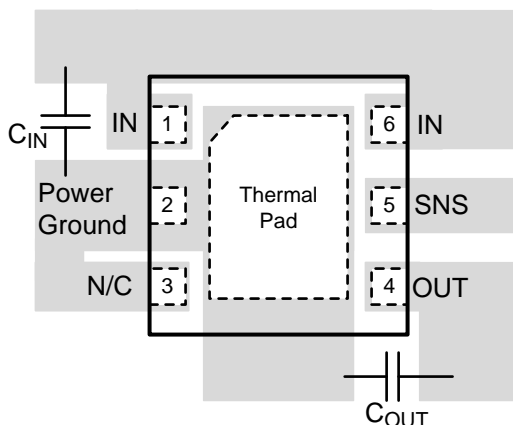

Figure 37. LP38690 WSON Package

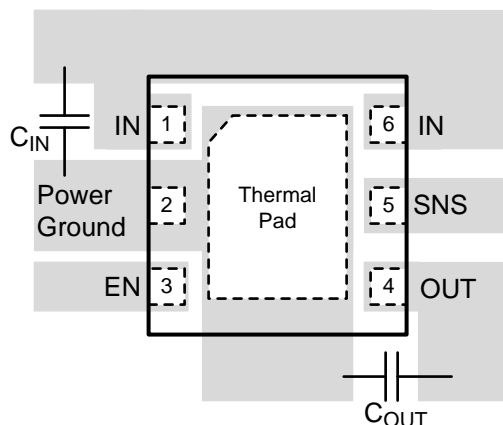

Figure 38. LP38692 WSON Package

10.3 WSON Mounting

The NGG0006A (No Pullback) 6-Lead WSON package requires specific mounting techniques which are detailed in the TI Application Report AN-1187 *Leadless Leadframe Package (LLP)* (SNOA401). Referring to the section *PCB Design Recommendations* (Page 5), it should be noted that the pad style which should be used with the WSON package is the NSMD (non-solder mask defined) type. Additionally, it is recommended the PCB terminal pads to be 0.2 mm longer than the package pads to create a solder fillet to improve reliability and inspection.

The input current is split between two IN pins, 1 and 6. The two IN pins must be connected together to ensure that the device can meet all specifications at the rated current.

The thermal dissipation of the WSON package is directly related to the printed circuit board construction and the amount of additional copper area connected to the DAP.

The DAP (exposed pad) on the bottom of the WSON package is connected to the die substrate with a conductive die attach adhesive. The DAP has no direct electrical (wire) connection to any of the pins. There is a parasitic PN junction between the die substrate and the device ground. As such, it is strongly recommended that the DAP be connected directly to the ground at device lead 2 (such as GND). Alternately, but not recommended, the DAP may be left floating (that is, no electrical connection). The DAP must not be connected to any potential other than ground.

10.4 RFI/EMI Susceptibility

Radio frequency interference (RFI) and electromagnetic interference (EMI) can degrade any integrated circuit's performance because of the small dimensions of the geometries inside the device. In applications where circuit sources are present which generate signals with significant high frequency energy content (> 1 MHz), care must be taken to ensure that this does not affect the device regulator.

If RFI/EMI noise is present on the input side of the regulator (such as applications where the input source comes from the output of a switching regulator), good ceramic bypass capacitors must be used at the IN pin of the device.

If a load is connected to the device output which switches at high speed (such as a clock), the high-frequency current pulses required by the load must be supplied by the capacitors on the device output. Since the bandwidth of the regulator loop is less than 100 kHz, the control circuitry cannot respond to load changes above that frequency. This means the effective output impedance of the device at frequencies above 100 kHz is determined only by the output capacitors.

In applications where the load is switching at high speed, the output of the device may need RF isolation from the load. It is recommended that some inductance be placed between the output capacitor and the load, and good RF bypass capacitors be placed directly across the load.

PCB layout is also critical in high noise environments, since RFI/EMI is easily radiated directly into PC traces. Noisy circuitry should be isolated from *clean* circuits where possible, and grounded through a separate path. At MHz frequencies, ground planes begin to look inductive and RFI/EMI can cause ground bounce across the ground plane. In multi-layer PCB applications, care should be taken in layout so that noisy power and ground planes do not radiate directly into adjacent layers which carry analog power and ground.

10.5 Output Noise

Noise is specified in two ways: *Spot Noise* or *Output Noise Density* is the RMS sum of all noise sources, measured at the regulator output, at a specific frequency (measured with a 1-Hz bandwidth). This type of noise is usually plotted on a curve as a function of frequency. *Total Output Noise* or *Broad-Band Noise* is the RMS sum of spot noise over a specified bandwidth, usually several decades of frequencies.

Attention should be paid to the units of measurement. Spot noise is measured in units $\mu\text{V}/\sqrt{\text{Hz}}$ or $\text{nV}/\sqrt{\text{Hz}}$ and total output noise is measured in μV_{RMS}

The primary source of noise in low-dropout regulators is the internal reference. Noise can be reduced in two ways: by increasing the transistor area or by increasing the current drawn by the internal reference. Increasing the area decreases the chance of fitting the die into a smaller package. Increasing the current drawn by the internal reference increases the total supply current (GND pin current).

11 Device and Documentation Support

11.1 Documentation Support

11.1.1 Related Documentation

For related documentation, see the following:

TI Application Report AN-1187 *Leadless Leadframe Package (LLP)* ([SNOA401](#))

11.2 Related Links

[Table 2](#) below lists quick access links. Categories include technical documents, support and community resources, tools and software, and quick access to sample or buy.

Table 2. Related Links

PARTS	PRODUCT FOLDER	SAMPLE & BUY	TECHNICAL DOCUMENTS	TOOLS & SOFTWARE	SUPPORT & COMMUNITY
LP38690	Click here	Click here	Click here	Click here	Click here
LP38692	Click here	Click here	Click here	Click here	Click here

11.3 Community Resources

The following links connect to TI community resources. Linked contents are provided "AS IS" by the respective contributors. They do not constitute TI specifications and do not necessarily reflect TI's views; see TI's [Terms of Use](#).

TI E2E™ Online Community *TI's Engineer-to-Engineer (E2E) Community*. Created to foster collaboration among engineers. At e2e.ti.com, you can ask questions, share knowledge, explore ideas and help solve problems with fellow engineers.

Design Support *TI's Design Support* Quickly find helpful E2E forums along with design support tools and contact information for technical support.

11.4 Trademarks

E2E is a trademark of Texas Instruments.
All other trademarks are the property of their respective owners.

11.5 Electrostatic Discharge Caution



These devices have limited built-in ESD protection. The leads should be shorted together or the device placed in conductive foam during storage or handling to prevent electrostatic damage to the MOS gates.

11.6 Glossary

[SLYZ022](#) — *TI Glossary*.

This glossary lists and explains terms, acronyms, and definitions.

12 Mechanical, Packaging, and Orderable Information

The following pages include mechanical, packaging, and orderable information. This information is the most current data available for the designated devices. This data is subject to change without notice and revision of this document. For browser-based versions of this data sheet, refer to the left-hand navigation.

PACKAGING INFORMATION

Orderable Device	Status (1)	Package Type	Package Drawing	Pins	Package Qty	Eco Plan (2)	Lead/Ball Finish (6)	MSL Peak Temp (3)	Op Temp (°C)	Device Marking (4/5)	Samples
LP38690DT-1.8/NOPB	ACTIVE	TO-252	NDP	3	75	Green (RoHS & no Sb/Br)	CU SN	Level-2-260C-1 YEAR	-40 to 125	LP38690 DT-1.8	Samples
LP38690DT-2.5/NOPB	ACTIVE	TO-252	NDP	3	75	Green (RoHS & no Sb/Br)	CU SN	Level-2-260C-1 YEAR	-40 to 125	LP38690 DT-2.5	Samples
LP38690DT-3.3	NRND	TO-252	NDP	3	75	TBD	Call TI	Call TI	-40 to 125	LP38690 DT-3.3	
LP38690DT-3.3/NOPB	ACTIVE	TO-252	NDP	3	75	Green (RoHS & no Sb/Br)	CU SN	Level-2-260C-1 YEAR	-40 to 125	LP38690 DT-3.3	Samples
LP38690DT-5.0/NOPB	ACTIVE	TO-252	NDP	3	75	Green (RoHS & no Sb/Br)	CU SN	Level-2-260C-1 YEAR	-40 to 125	LP38690 DT-5.0	Samples
LP38690DTX-1.8/NOPB	ACTIVE	TO-252	NDP	3	2500	Green (RoHS & no Sb/Br)	CU SN	Level-2-260C-1 YEAR	-40 to 125	LP38690 DT-1.8	Samples
LP38690DTX-2.5/NOPB	ACTIVE	TO-252	NDP	3	2500	Green (RoHS & no Sb/Br)	CU SN	Level-2-260C-1 YEAR	-40 to 125	LP38690 DT-2.5	Samples
LP38690DTX-3.3/NOPB	ACTIVE	TO-252	NDP	3	2500	Green (RoHS & no Sb/Br)	CU SN	Level-2-260C-1 YEAR	-40 to 125	LP38690 DT-3.3	Samples
LP38690DTX-5.0/NOPB	ACTIVE	TO-252	NDP	3	2500	Green (RoHS & no Sb/Br)	CU SN	Level-2-260C-1 YEAR	-40 to 125	LP38690 DT-5.0	Samples
LP38690SD-1.8	NRND	WSON	NGG	6	1000	TBD	Call TI	Call TI	-40 to 125	L113B	
LP38690SD-1.8/NOPB	ACTIVE	WSON	NGG	6	1000	Green (RoHS & no Sb/Br)	CU NIPDAU CU SN	Level-1-260C-UNLIM	-40 to 125	L113B	Samples
LP38690SD-2.5/NOPB	ACTIVE	WSON	NGG	6	1000	Green (RoHS & no Sb/Br)	CU SN	Level-1-260C-UNLIM	-40 to 125	L114B	Samples
LP38690SD-3.3/NOPB	ACTIVE	WSON	NGG	6	1000	Green (RoHS & no Sb/Br)	CU NIPDAU CU SN	Level-1-260C-UNLIM	-40 to 125	L115B	Samples
LP38690SD-5.0/NOPB	ACTIVE	WSON	NGG	6	1000	Green (RoHS & no Sb/Br)	CU NIPDAU CU SN	Level-1-260C-UNLIM	-40 to 125	L116B	Samples
LP38690SDX-3.3/NOPB	ACTIVE	WSON	NGG	6	4500	Green (RoHS & no Sb/Br)	CU NIPDAU CU SN	Level-1-260C-UNLIM	-40 to 125	L115B	Samples
LP38690SDX-5.0/NOPB	ACTIVE	WSON	NGG	6	4500	Green (RoHS & no Sb/Br)	CU NIPDAU CU SN	Level-1-260C-UNLIM	-40 to 125	L116B	Samples
LP38692MP-1.8/NOPB	ACTIVE	SOT-223	NDC	5	1000	Green (RoHS & no Sb/Br)	CU SN	Level-1-260C-UNLIM	-40 to 125	LJPB	Samples
LP38692MP-2.5	NRND	SOT-223	NDC	5	1000	TBD	Call TI	Call TI	-40 to 125	LJRB	

Orderable Device	Status (1)	Package Type	Package Drawing	Pins	Package Qty	Eco Plan (2)	Lead/Ball Finish (6)	MSL Peak Temp (3)	Op Temp (°C)	Device Marking (4/5)	Samples
LP38692MP-2.5/NOPB	ACTIVE	SOT-223	NDC	5	1000	Green (RoHS & no Sb/Br)	CU SN	Level-1-260C-UNLIM	-40 to 125	LJRB	Samples
LP38692MP-3.3	NRND	SOT-223	NDC	5	1000	TBD	Call TI	Call TI	-40 to 125	LJSB	
LP38692MP-3.3/NOPB	ACTIVE	SOT-223	NDC	5	1000	Green (RoHS & no Sb/Br)	CU SN	Level-1-260C-UNLIM	-40 to 125	LJSB	Samples
LP38692MP-5.0	NRND	SOT-223	NDC	5	1000	TBD	Call TI	Call TI	-40 to 125	LJTB	
LP38692MP-5.0/NOPB	ACTIVE	SOT-223	NDC	5	1000	Green (RoHS & no Sb/Br)	CU SN	Level-1-260C-UNLIM	-40 to 125	LJTB	Samples
LP38692MPX-1.8/NOPB	ACTIVE	SOT-223	NDC	5	2000	Green (RoHS & no Sb/Br)	CU SN	Level-1-260C-UNLIM	-40 to 125	LJPB	Samples
LP38692MPX-3.3/NOPB	ACTIVE	SOT-223	NDC	5	2000	Green (RoHS & no Sb/Br)	CU SN	Level-1-260C-UNLIM	-40 to 125	LJSB	Samples
LP38692MPX-5.0/NOPB	ACTIVE	SOT-223	NDC	5	2000	Green (RoHS & no Sb/Br)	CU SN	Level-1-260C-UNLIM	-40 to 125	LJTB	Samples
LP38692SD-1.8/NOPB	ACTIVE	WSON	NGG	6	1000	Green (RoHS & no Sb/Br)	CU SN	Level-1-260C-UNLIM	-40 to 125	L123B	Samples
LP38692SD-2.5/NOPB	ACTIVE	WSON	NGG	6	1000	Green (RoHS & no Sb/Br)	CU SN	Level-1-260C-UNLIM	-40 to 125	L124B	Samples
LP38692SD-3.3/NOPB	ACTIVE	WSON	NGG	6	1000	Green (RoHS & no Sb/Br)	CU SN	Level-1-260C-UNLIM	-40 to 125	L125B	Samples
LP38692SD-5.0/NOPB	ACTIVE	WSON	NGG	6	1000	Green (RoHS & no Sb/Br)	CU SN	Level-1-260C-UNLIM	-40 to 125	L126B	Samples
LP38692SDX-3.3/NOPB	ACTIVE	WSON	NGG	6	4500	Green (RoHS & no Sb/Br)	CU SN	Level-1-260C-UNLIM	-40 to 125	L125B	Samples
LP38692SDX-5.0/NOPB	ACTIVE	WSON	NGG	6	4500	Green (RoHS & no Sb/Br)	CU SN	Level-1-260C-UNLIM	-40 to 125	L126B	Samples

(1) The marketing status values are defined as follows:

ACTIVE: Product device recommended for new designs.

LIFEBUY: TI has announced that the device will be discontinued, and a lifetime-buy period is in effect.

NRND: Not recommended for new designs. Device is in production to support existing customers, but TI does not recommend using this part in a new design.

PREVIEW: Device has been announced but is not in production. Samples may or may not be available.

OBSOLETE: TI has discontinued the production of the device.

(2) **RoHS:** TI defines "RoHS" to mean semiconductor products that are compliant with the current EU RoHS requirements for all 10 RoHS substances, including the requirement that RoHS substance do not exceed 0.1% by weight in homogeneous materials. Where designed to be soldered at high temperatures, "RoHS" products are suitable for use in specified lead-free processes. TI may reference these types of products as "Pb-Free".

RoHS Exempt: TI defines "RoHS Exempt" to mean products that contain lead but are compliant with EU RoHS pursuant to a specific EU RoHS exemption.

Green: TI defines "Green" to mean the content of Chlorine (Cl) and Bromine (Br) based flame retardants meet JS709B low halogen requirements of ≤ 1000 ppm threshold. Antimony trioxide based flame retardants must also meet the ≤ 1000 ppm threshold requirement.

(3) MSL, Peak Temp. - The Moisture Sensitivity Level rating according to the JEDEC industry standard classifications, and peak solder temperature.

(4) There may be additional marking, which relates to the logo, the lot trace code information, or the environmental category on the device.

(5) Multiple Device Markings will be inside parentheses. Only one Device Marking contained in parentheses and separated by a "~" will appear on a device. If a line is indented then it is a continuation of the previous line and the two combined represent the entire Device Marking for that device.

(6) Lead/Ball Finish - Orderable Devices may have multiple material finish options. Finish options are separated by a vertical ruled line. Lead/Ball Finish values may wrap to two lines if the finish value exceeds the maximum column width.

Important Information and Disclaimer: The information provided on this page represents TI's knowledge and belief as of the date that it is provided. TI bases its knowledge and belief on information provided by third parties, and makes no representation or warranty as to the accuracy of such information. Efforts are underway to better integrate information from third parties. TI has taken and continues to take reasonable steps to provide representative and accurate information but may not have conducted destructive testing or chemical analysis on incoming materials and chemicals. TI and TI suppliers consider certain information to be proprietary, and thus CAS numbers and other limited information may not be available for release.

In no event shall TI's liability arising out of such information exceed the total purchase price of the TI part(s) at issue in this document sold by TI to Customer on an annual basis.

TAPE AND REEL INFORMATION



QUADRANT ASSIGNMENTS FOR PIN 1 ORIENTATION IN TAPE



*All dimensions are nominal

Device	Package Type	Package Drawing	Pins	SPQ	Reel Diameter (mm)	Reel Width W1 (mm)	A0 (mm)	B0 (mm)	K0 (mm)	P1 (mm)	W (mm)	Pin1 Quadrant
LP38690DTX-1.8/NOPB	TO-252	NDP	3	2500	330.0	16.4	6.9	10.5	2.7	8.0	16.0	Q2
LP38690DTX-2.5/NOPB	TO-252	NDP	3	2500	330.0	16.4	6.9	10.5	2.7	8.0	16.0	Q2
LP38690DTX-3.3/NOPB	TO-252	NDP	3	2500	330.0	16.4	6.9	10.5	2.7	8.0	16.0	Q2
LP38690DTX-5.0/NOPB	TO-252	NDP	3	2500	330.0	16.4	6.9	10.5	2.7	8.0	16.0	Q2
LP38690SD-1.8	WSON	NGG	6	1000	178.0	12.4	3.3	3.3	1.0	8.0	12.0	Q1
LP38690SD-1.8/NOPB	WSON	NGG	6	1000	180.0	12.4	3.3	3.3	1.0	8.0	12.0	Q1
LP38690SD-2.5/NOPB	WSON	NGG	6	1000	178.0	12.4	3.3	3.3	1.0	8.0	12.0	Q1
LP38690SD-3.3/NOPB	WSON	NGG	6	1000	180.0	12.4	3.3	3.3	1.0	8.0	12.0	Q1
LP38690SD-5.0/NOPB	WSON	NGG	6	1000	180.0	12.4	3.3	3.3	1.0	8.0	12.0	Q1
LP38690SDX-3.3/NOPB	WSON	NGG	6	4500	330.0	12.4	3.3	3.3	1.0	8.0	12.0	Q1
LP38690SDX-5.0/NOPB	WSON	NGG	6	4500	330.0	12.4	3.3	3.3	1.0	8.0	12.0	Q1
LP38692MP-1.8/NOPB	SOT-223	NDC	5	1000	330.0	16.4	7.0	7.5	2.2	12.0	16.0	Q3
LP38692MP-2.5	SOT-223	NDC	5	1000	330.0	16.4	7.0	7.5	2.2	12.0	16.0	Q3
LP38692MP-2.5/NOPB	SOT-223	NDC	5	1000	330.0	16.4	7.0	7.5	2.2	12.0	16.0	Q3
LP38692MP-3.3	SOT-223	NDC	5	1000	330.0	16.4	7.0	7.5	2.2	12.0	16.0	Q3
LP38692MP-3.3/NOPB	SOT-223	NDC	5	1000	330.0	16.4	7.0	7.5	2.2	12.0	16.0	Q3
LP38692MP-5.0	SOT-223	NDC	5	1000	330.0	16.4	7.0	7.5	2.2	12.0	16.0	Q3
LP38692MP-5.0/NOPB	SOT-223	NDC	5	1000	330.0	16.4	7.0	7.5	2.2	12.0	16.0	Q3

Device	Package Type	Package Drawing	Pins	SPQ	Reel Diameter (mm)	Reel Width W1 (mm)	A0 (mm)	B0 (mm)	K0 (mm)	P1 (mm)	W (mm)	Pin1 Quadrant
LP38692MPX-1.8/NOPB	SOT-223	NDC	5	2000	330.0	16.4	7.0	7.5	2.2	12.0	16.0	Q3
LP38692MPX-3.3/NOPB	SOT-223	NDC	5	2000	330.0	16.4	7.0	7.5	2.2	12.0	16.0	Q3
LP38692MPX-5.0/NOPB	SOT-223	NDC	5	2000	330.0	16.4	7.0	7.5	2.2	12.0	16.0	Q3
LP38692SD-1.8/NOPB	WSON	NGG	6	1000	178.0	12.4	3.3	3.3	1.0	8.0	12.0	Q1
LP38692SD-2.5/NOPB	WSON	NGG	6	1000	178.0	12.4	3.3	3.3	1.0	8.0	12.0	Q1
LP38692SD-3.3/NOPB	WSON	NGG	6	1000	178.0	12.4	3.3	3.3	1.0	8.0	12.0	Q1
LP38692SD-5.0/NOPB	WSON	NGG	6	1000	178.0	12.4	3.3	3.3	1.0	8.0	12.0	Q1
LP38692SDX-3.3/NOPB	WSON	NGG	6	4500	330.0	12.4	3.3	3.3	1.0	8.0	12.0	Q1
LP38692SDX-5.0/NOPB	WSON	NGG	6	4500	330.0	12.4	3.3	3.3	1.0	8.0	12.0	Q1

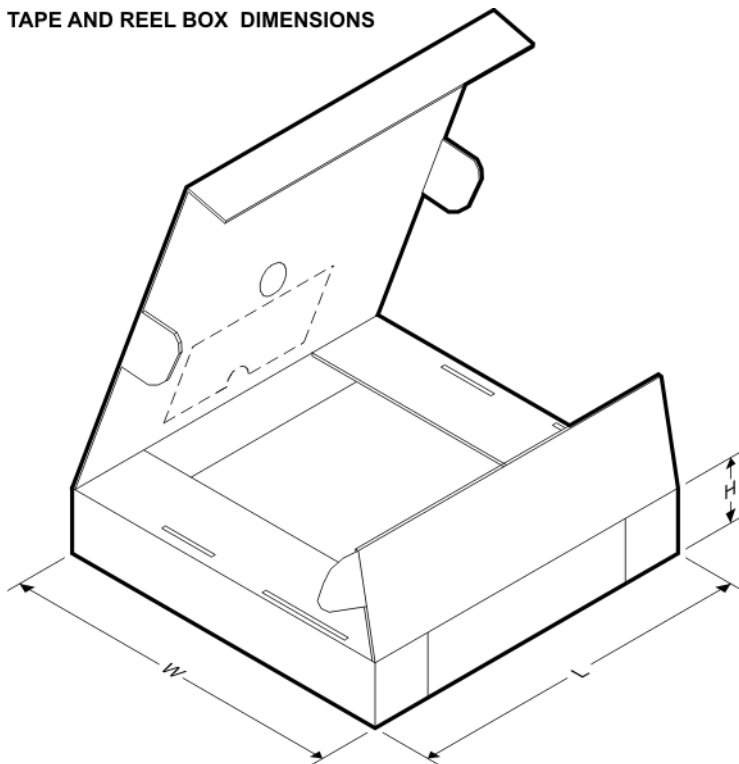
TAPE AND REEL BOX DIMENSIONS

*All dimensions are nominal

Device	Package Type	Package Drawing	Pins	SPQ	Length (mm)	Width (mm)	Height (mm)
LP38690DTX-1.8/NOPB	TO-252	NDP	3	2500	367.0	367.0	38.0
LP38690DTX-2.5/NOPB	TO-252	NDP	3	2500	367.0	367.0	38.0
LP38690DTX-3.3/NOPB	TO-252	NDP	3	2500	367.0	367.0	38.0
LP38690DTX-5.0/NOPB	TO-252	NDP	3	2500	367.0	367.0	38.0
LP38690SD-1.8	WSON	NGG	6	1000	210.0	185.0	35.0
LP38690SD-1.8/NOPB	WSON	NGG	6	1000	203.0	203.0	35.0
LP38690SD-2.5/NOPB	WSON	NGG	6	1000	210.0	185.0	35.0
LP38690SD-3.3/NOPB	WSON	NGG	6	1000	203.0	203.0	35.0

Device	Package Type	Package Drawing	Pins	SPQ	Length (mm)	Width (mm)	Height (mm)
LP38690SD-5.0/NOPB	WSON	NGG	6	1000	203.0	203.0	35.0
LP38690SDX-3.3/NOPB	WSON	NGG	6	4500	346.0	346.0	35.0
LP38690SDX-5.0/NOPB	WSON	NGG	6	4500	346.0	346.0	35.0
LP38692MP-1.8/NOPB	SOT-223	NDC	5	1000	367.0	367.0	35.0
LP38692MP-2.5	SOT-223	NDC	5	1000	367.0	367.0	35.0
LP38692MP-2.5/NOPB	SOT-223	NDC	5	1000	367.0	367.0	35.0
LP38692MP-3.3	SOT-223	NDC	5	1000	367.0	367.0	35.0
LP38692MP-3.3/NOPB	SOT-223	NDC	5	1000	367.0	367.0	35.0
LP38692MP-5.0	SOT-223	NDC	5	1000	367.0	367.0	35.0
LP38692MP-5.0/NOPB	SOT-223	NDC	5	1000	367.0	367.0	35.0
LP38692MPX-1.8/NOPB	SOT-223	NDC	5	2000	367.0	367.0	35.0
LP38692MPX-3.3/NOPB	SOT-223	NDC	5	2000	367.0	367.0	35.0
LP38692MPX-5.0/NOPB	SOT-223	NDC	5	2000	367.0	367.0	35.0
LP38692SD-1.8/NOPB	WSON	NGG	6	1000	210.0	185.0	35.0
LP38692SD-2.5/NOPB	WSON	NGG	6	1000	210.0	185.0	35.0
LP38692SD-3.3/NOPB	WSON	NGG	6	1000	210.0	185.0	35.0
LP38692SD-5.0/NOPB	WSON	NGG	6	1000	210.0	185.0	35.0
LP38692SDX-3.3/NOPB	WSON	NGG	6	4500	367.0	367.0	35.0
LP38692SDX-5.0/NOPB	WSON	NGG	6	4500	367.0	367.0	35.0

EXAMPLE BOARD LAYOUT

NDP0003B

TO-252 - 2.55 mm max height

TRANSISTOR OUTLINE

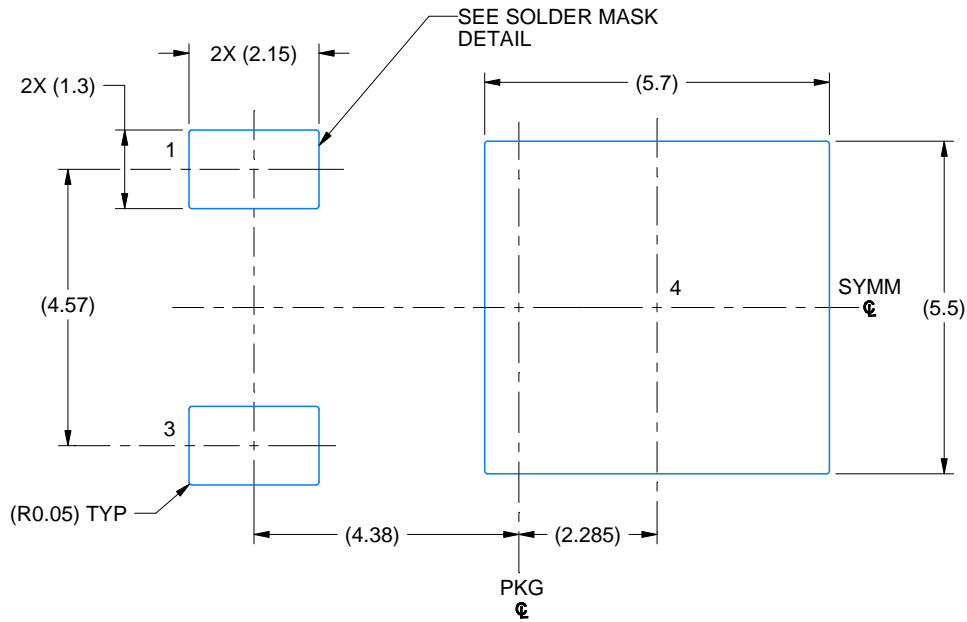

LAND PATTERN EXAMPLE
EXPOSED METAL SHOWN
SCALE: 8X

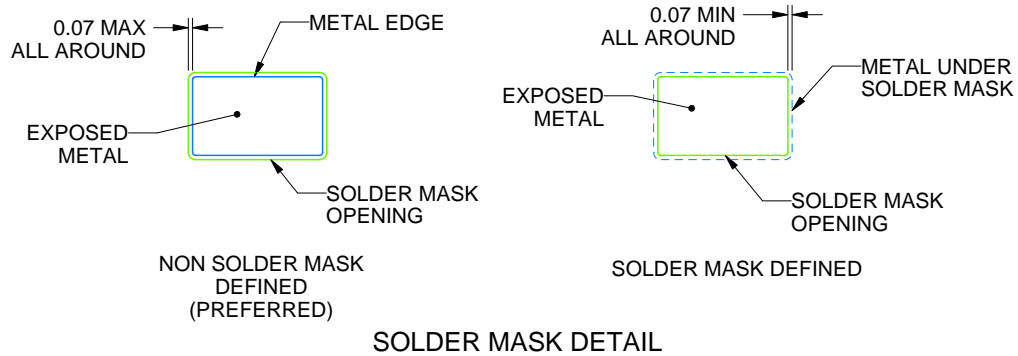

SOLDER MASK DETAIL

4219870/A 03/2018

NOTES: (continued)

4. This package is designed to be soldered to a thermal pad on the board. For more information, see Texas Instruments literature numbers SLMA002(www.ti.com/lit/slm002) and SLMA004 (www.ti.com/lit/slma004).
5. Vias are optional depending on application, refer to device data sheet. It is recommended that vias under paste be filled, plugged or tented.

EXAMPLE STENCIL DESIGN

NDP0003B

TO-252 - 2.55 mm max height

TRANSISTOR OUTLINE

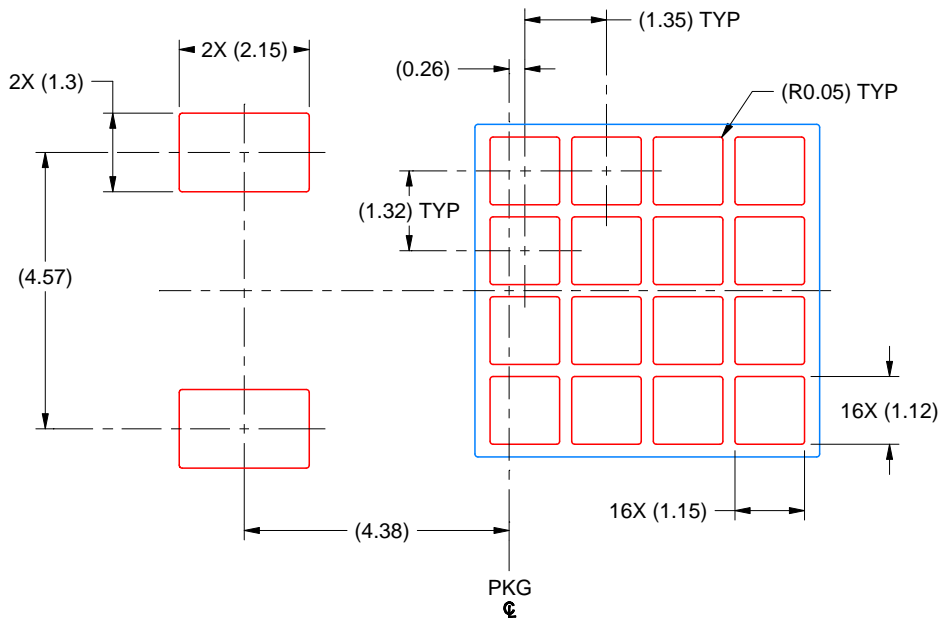

SOLDER PASTE EXAMPLE
BASED ON 0.125 MM THICK STENCIL
SCALE: 8X

4219870/A 03/2018

NOTES: (continued)

6. Laser cutting apertures with trapezoidal walls and rounded corners may offer better paste release. IPC-7525 may have alternate design recommendations.
7. Board assembly site may have different recommendations for stencil design.

IMPORTANT NOTICE AND DISCLAIMER

TI PROVIDES TECHNICAL AND RELIABILITY DATA (INCLUDING DATASHEETS), DESIGN RESOURCES (INCLUDING REFERENCE DESIGNS), APPLICATION OR OTHER DESIGN ADVICE, WEB TOOLS, SAFETY INFORMATION, AND OTHER RESOURCES "AS IS" AND WITH ALL FAULTS, AND DISCLAIMS ALL WARRANTIES, EXPRESS AND IMPLIED, INCLUDING WITHOUT LIMITATION ANY IMPLIED WARRANTIES OF MERCHANTABILITY, FITNESS FOR A PARTICULAR PURPOSE OR NON-INFRINGEMENT OF THIRD PARTY INTELLECTUAL PROPERTY RIGHTS.

These resources are intended for skilled developers designing with TI products. You are solely responsible for (1) selecting the appropriate TI products for your application, (2) designing, validating and testing your application, and (3) ensuring your application meets applicable standards, and any other safety, security, or other requirements. These resources are subject to change without notice. TI grants you permission to use these resources only for development of an application that uses the TI products described in the resource. Other reproduction and display of these resources is prohibited. No license is granted to any other TI intellectual property right or to any third party intellectual property right. TI disclaims responsibility for, and you will fully indemnify TI and its representatives against, any claims, damages, costs, losses, and liabilities arising out of your use of these resources.

TI's products are provided subject to TI's Terms of Sale (www.ti.com/legal/termsofsale.html) or other applicable terms available either on ti.com or provided in conjunction with such TI products. TI's provision of these resources does not expand or otherwise alter TI's applicable warranties or warranty disclaimers for TI products.

Mailing Address: Texas Instruments, Post Office Box 655303, Dallas, Texas 75265
Copyright © 2019, Texas Instruments Incorporated

Looking for pricing, stock, or lifecycle information?

Click below to explore more details on WIN SOURCE:

 [View LP38690SD-2.5/NOPB on WIN SOURCE](#)

 [Texas Instruments](#) Information

Optimize Your Supply Chain with WIN SOURCE Solutions

-  Global Sourcing Solution
-  Obsolete Management
-  Cost Control Management
-  Shortage Management
-  Alternative Solution
-  Excess Inventory Management