



**THE DATASHEET OF
LP8340CLD-2.5/NOPB**



LP8340 Low Dropout, Low I_Q , 1.0A CMOS Linear Regulator

Check for Samples: [LP8340](#)

FEATURES

- $\pm 1.5\%$ Typical V_{OUT} Tolerance
- 420mV Typical Dropout @ 1.0A ($V_O = 5V$)
- Wide Operating Range 2.7V to 10V
- Internal 1.0A PMOS Output Transistor
- 19 μ A Typical Quiescent Current
- Thermal Overload Limiting
- Foldback Current Limiting
- Zener Trimmed Bandgap Reference
- Space Saving WSON package
- Temperature Range
 - LP8340C 0°C to 125°C
 - LP8340I –40°C to 125°C

APPLICATIONS

- Hard Disk Drives
- Notebook Computers
- Battery Powered Electronics
- Portable Instrumentation

Typical Applications

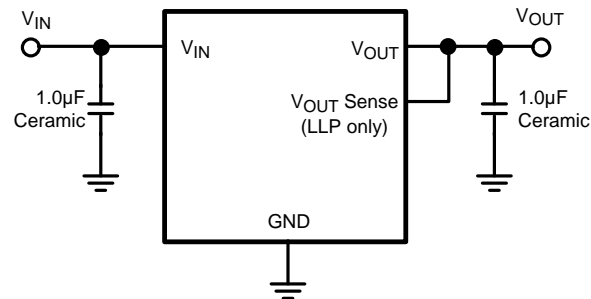

Figure 1. Fixed V_{OUT}

DESCRIPTION

The LP8340 low-dropout CMOS linear regulator is available in 5V, 3.3V, 2.5V, 1.8V and adjustable output versions. Packaged in the 6ld WSON package and 3ld PFM. The LP8340 can deliver up to 1.0A output current.

Typical dropout voltage is 420mV at 1.0A for the 5.0V version, 540mV at 1.0A for the 3.3V version, 670mV at 1.0A for the 2.5V version and 680mV at 800mA for the 1.8V version.

The LP8340 includes a zener trimmed bandgap voltage reference, foldback current limiting and thermal overload limiting.

The LP8340 features a PMOS output transistor which unlike PNP type low dropout regulators requires no base drive current. This allows the device ground current to remain less than 50 μ A over operating temperature, supply voltage and irrespective of the load current.



Please be aware that an important notice concerning availability, standard warranty, and use in critical applications of Texas Instruments semiconductor products and disclaimers thereto appears at the end of this data sheet.

All trademarks are the property of their respective owners.

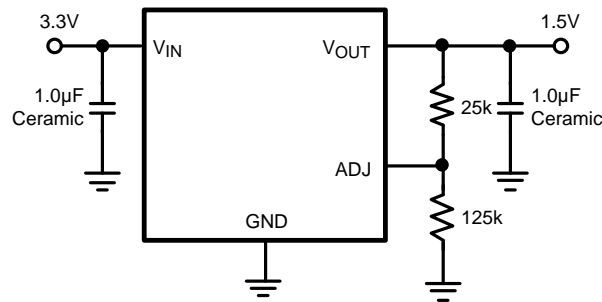

Figure 2. Adjustable V_{OUT}

Connection Diagrams

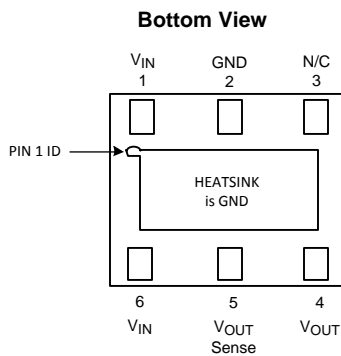

Figure 3. 6-Pin WSON Package
Fixed Output Voltage
See Package Number NGD0006A

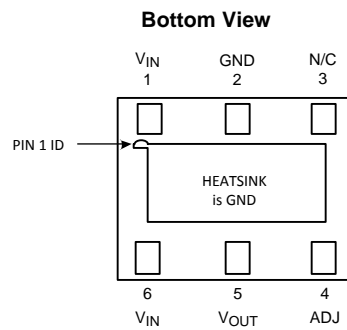

Figure 4. 6-Pin WSON Package
Adjustable Output Voltage
See Package Number NGD0006A

NOTE

V_{IN} Pins (Pin 1 & 6) must be connected together externally for full 1 amp operation (500mA max per pin).

V_{OUT} Sense (Pin 5) must be connected to V_{OUT} (Pin 4).

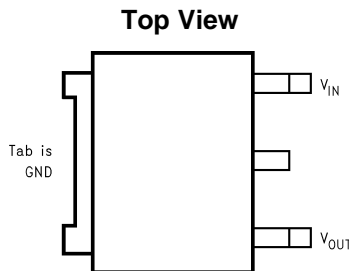

Figure 5. PFM Package
See Package Number NDP0003B



These devices have limited built-in ESD protection. The leads should be shorted together or the device placed in conductive foam during storage or handling to prevent electrostatic damage to the MOS gates.

Absolute Maximum Ratings⁽¹⁾⁽²⁾⁽³⁾

V_{IN} , V_{OUT} , V_{OUT} Sense, ADJ		-0.3V to 12V
Storage Temperature Range		-65°C to 160°C
Junction Temperature (T_J)		150°C
Power Dissipation		See ⁽⁴⁾
ESD Rating	Human Body Model ⁽⁵⁾	2kV
	Machine Model	200V

- (1) Absolute Maximum ratings indicate limits beyond which damage may occur. Electrical specifications do not apply when operating the device outside of its rated operating conditions.
- (2) All voltages are with respect to the potential at the ground pin.
- (3) If Military/Aerospace specified devices are required, please contact the Texas Instruments Sales Office/ Distributors for availability and specifications.

- (4) Maximum Power dissipation for the device is calculated using the following equations: $P_D = \frac{T_{J(MAX)} - T_A}{\theta_{JA}}$ where $T_{J(MAX)}$ is the maximum junction temperature, T_A is the ambient temperature, and θ_{JA} is the junction-to-ambient thermal resistance. The value of the θ_{JA} for the WSON package is specifically dependant on the PCB trace area, trace material, and the number of layers and thermal vias. For improved thermal resistance and power dissipation for the WSON package, refer to Application Note AN-1187 ([SNOA401](#)).
- (5) Human body model 1.5kΩ in series with 100pF.

Operating Ratings⁽¹⁾⁽²⁾

Supply Voltage	2.7 to 10V
Temperature Range	
LP8340C	0°C to 125°C
LP8340I	-40°C to 125°C

- (1) Absolute Maximum ratings indicate limits beyond which damage may occur. Electrical specifications do not apply when operating the device outside of its rated operating conditions.
- (2) All voltages are with respect to the potential at the ground pin.

LP8340C Electrical Characteristics

Unless otherwise specified all limits ensured for $V_{IN} = V_O + 1V$, $C_{IN} = C_{OUT} = 10\mu F$, $T_J = 25^\circ C$. **Boldface** limits apply over the full operating temperature range of $T_J = 0^\circ C$ to $125^\circ C$

Symbol	Parameter	Conditions	Min ⁽¹⁾	Typ ⁽²⁾	Max ⁽¹⁾	Units
V_{IN}	Input Voltage	LP8340-ADJ, 1.8, 2.5 LP8340-3.3, 5.0	2.7		10 10	V
V_{OUT}	Output Voltage	LP8340-ADJ, ADJ = OUT $I_{OUT} = 10mA$, $V_{IN} = 2.7V$, $T_J = 25^\circ C$ $100\mu A \leq I_{OUT} \leq 800mA$, $3.0V \leq V_{IN} \leq V_{OUT} + 4V$ $800mA < I_{OUT} \leq 1.0A$, $3.2V \leq V_{IN} \leq V_{OUT} + 4V$	1.231 1.213 1.213	1.250	1.269 1.288 1.288	V
		LP8340-1.8 $I_{OUT} = 10mA$, $V_{IN} = 2.8V$, $T_J = 25^\circ C$ $100\mu A \leq I_{OUT} \leq 800mA$, $3.2V \leq V_{IN} \leq 6V$ $800mA < I_{OUT} \leq 1.0A$, $3.4V \leq V_{IN} \leq 6V$	1.773 1.746 1.746	1.800	1.827 1.854 1.854	V
		LP8340-2.5 $I_{OUT} = 10mA$, $V_{IN} = 3.8V$, $T_J = 25^\circ C$ $100\mu A \leq I_{OUT} \leq 1.0A$, $3.8V \leq V_{IN} \leq 6.5V$	2.463 2.425	2.500	2.538 2.575	V
		LP8340-3.3 $I_{OUT} = 10mA$, $V_{IN} = 4.3V$, $T_J = 25^\circ C$ $100\mu A \leq I_{OUT} \leq 1.0A$, $4.3V \leq V_{IN} \leq 7.5V$	3.250 3.201	3.300	3.350 3.399	V
		LP8340-5.0 $I_{OUT} = 10mA$, $V_{IN} = 6V$, $T_J = 25^\circ C$ $100\mu A \leq I_{OUT} \leq 1.0A$, $6V \leq V_{IN} \leq 9V$	4.925 4.850	5.000	5.075 5.150	V

- (1) All limits are specified by testing or statistical analysis.
- (2) Typical Values represent the most likely parametric norm.

LP8340C Electrical Characteristics (continued)

Unless otherwise specified all limits ensured for $V_{IN} = V_O + 1V$, $C_{IN} = C_{OUT} = 10\mu F$, $T_J = 25^\circ C$. **Boldface** limits apply over the full operating temperature range of $T_J = 0^\circ C$ to $125^\circ C$

Symbol	Parameter	Conditions	Min ⁽¹⁾	Typ ⁽²⁾	Max ⁽¹⁾	Units
ΔV_O	Load Regulation	LP8340-ADJ, ADJ=OUT $I_{OUT} = 1mA$ to $1.0A$, $V_{IN} = 3.2V$		6	25	mV
		LP8340-1.8 $I_{OUT} = 1mA$ to $1.0A$, $V_{IN} = 3.4V$		8	30	
		LP8340-2.5 $I_{OUT} = 1mA$ to $1.0A$, $V_{IN} = 3.5V$		15	50	
		LP8340-3.3 $I_{OUT} = 1mA$ to $1.0A$, $V_{IN} = 4.3V$		20	75	
		LP8340-5.0 $I_{OUT} = 1mA$ to $1.0A$, $V_{IN} = 6V$		25	100	
ΔV_O	Line Regulation	$V_{OUT} + 0.5V \leq V_{IN} \leq 10V$, $I_{OUT} = 25mA$ ⁽³⁾		4	15	mV
$V_{IN} - V_O$	Dropout Voltage ⁽³⁾⁽⁴⁾	LP8340-1.8 $I_{OUT} = 800mA$		680	1400	mV
		LP8340-2.5 $I_{OUT} = 800mA$		550	1000	
		LP8340-2.5 $I_{OUT} = 1.0A$		670	1300	
		LP8340-3.3 LP8340-ADJ, $V_{OUT} = 3.3V$, $I_{OUT} = 800mA$		420	800	
		LP8340-3.3 LP8340-ADJ, $I_{OUT} = 1.0A$		540	1000	
		LP8340-5.0 $I_{OUT} = 800mA$		330	650	
		LP8340-5.0 $I_{OUT} = 1.0A$		420	800	
I_Q	Quiescent Current	$V_{IN} \leq 10V$		19	50	μA
	Minimum Load Current	$V_{IN} - V_{OUT} \leq 4V$			100	μA
I_{LIMIT}	Foldback Current Limit	$V_{IN} - V_{OUT} > 5V$		450		mA
		$V_{IN} - V_{OUT} < 4V$		1600		
	Ripple Rejection Ratio	$V_{IN} (dc) = V_{OUT} + 2V$ $V_{IN} (ac) = 1 V_{P-P} @ 120Hz$	48	55		dB
T_{SD}	Thermal Shutdown Temp. Thermal Shutdown Hyst.			160 10		$^\circ C$
	ADJ Input Leakage Current	$V_{ADJ} = 1.5V$ or $0V$		± 0.01	± 100	nA
	V_{OUT} Leakage Current	LP8340-ADJ ADJ = OUT, $V_{OUT} = 2V$, $V_{IN} = 10V$			10	μA
		LP8340-1.8, $V_{OUT} = 2.5V$, $V_{IN} = 10V$			10	
		LP8340-2.5, $V_{OUT} = 3.5V$, $V_{IN} = 10V$			10	
		LP8340-3.3, $V_{OUT} = 4V$, $V_{IN} = 10V$			10	
		LP8340-5.0, $V_{OUT} = 6V$, $V_{IN} = 10V$			10	
e_n	Output Noise	10Hz to 10kHz, $R_L = 1k\Omega$, $C_{OUT} = 10\mu F$		250		μV_{rms}

(3) Condition does not apply to input voltages below 2.7V since this is the minimum input operating voltage.

(4) Dropout voltage is measured by reducing V_{IN} until V_O drops 100mV from its normal value.

LP8340I Electrical Characteristics

Unless otherwise specified all limits ensured for $V_{IN} = V_O + 1V$, $C_{IN} = C_{OUT} = 10\mu F$, $T_J = 25^\circ C$. **Boldface** limits apply over the full operating temperature range of $T_J = -40^\circ C$ to $125^\circ C$

Symbol	Parameter	Conditions	Min ⁽¹⁾	Typ ⁽²⁾	Max ⁽¹⁾	Units
V_{IN}	Input Voltage	LP8340-ADJ, 1.8, 2.5 LP8340-3.3, 5.0	2.7		10 10	V
V_{OUT}	Output Voltage	LP8340-ADJ, ADJ = OUT $I_{OUT} = 10mA$, $V_{IN} = 2.7V$, $T_J = 25^\circ C$ $100\mu A \leq I_{OUT} \leq 800mA$, $3.0V \leq V_{IN} \leq V_{OUT} + 4V$ $800mA < I_{OUT} \leq 1.0A$, $3.2V \leq V_{IN} \leq V_{OUT} + 4V$	1.231 1.213 1.213	1.250	1.269 1.288 1.288	V
		LP8340-1.8 $I_{OUT} = 10mA$, $V_{IN} = 2.8V$, $T_J = 25^\circ C$ $100\mu A \leq I_{OUT} \leq 800mA$, $3.2V \leq V_{IN} \leq 6V$ $800mA < I_{OUT} \leq 1.0A$, $3.4V \leq V_{IN} \leq 6V$	1.773 1.746 1.746	1.800	1.827 1.854 1.854	V
		LP8340-2.5 $I_{OUT} = 10mA$, $V_{IN} = 3.8V$, $T_J = 25^\circ C$ $100\mu A \leq I_{OUT} \leq 1.0A$, $3.8V \leq V_{IN} \leq 6.5V$	2.463 2.425	2.500	2.538 2.575	V
		LP8340-3.3 $I_{OUT} = 10mA$, $V_{IN} = 4.3V$, $T_J = 25^\circ C$ $100\mu A \leq I_{OUT} \leq 1.0A$, $4.3V \leq V_{IN} \leq 7.5V$	3.250 3.201	3.300	3.350 3.399	V
		LP8340-5.0 $I_{OUT} = 10mA$, $V_{IN} = 6V$, $T_J = 25^\circ C$ $100\mu A \leq I_{OUT} \leq 1.0A$, $6V \leq V_{IN} \leq 9V$	4.925 4.850	5.000	5.075 5.150	V
ΔV_O	Load Regulation	LP8340-ADJ, ADJ=OUT $I_{OUT} = 1mA$ to $1.0A$, $V_{IN} = 3.2V$		6	25	mV
		LP8340-1.8 $I_{OUT} = 1mA$ to $1.0A$, $V_{IN} = 3.4V$		8	30	
		LP8340-2.5 $I_{OUT} = 1mA$ to $1.0A$, $V_{IN} = 3.5V$		15	50	
		LP8340-3.3 $I_{OUT} = 1mA$ to $1.0A$, $V_{IN} = 4.3V$		20	75	
		LP8340-5.0 $I_{OUT} = 1mA$ to $1.0A$, $V_{IN} = 6V$		25	100	
ΔV_O	Line Regulation	$V_{OUT} + 0.5V \leq V_{IN} \leq 10V$, $I_{OUT} = 25mA$ ⁽³⁾		4	15	mV
$V_{IN} - V_O$	Dropout Voltage ⁽³⁾⁽⁴⁾	LP8340-1.8 $I_{OUT} = 800mA$		680	1400	mV
		LP8340-2.5 $I_{OUT} = 800mA$		550	1000	
		LP8340-2.5 $I_{OUT} = 1.0A$		670	1300	
		LP8340-3.3 LP8340-ADJ, $V_{OUT} = 3.3V$, $I_{OUT} = 800mA$		420	800	
		LP8340-3.3 LP8340-ADJ, $I_{OUT} = 1.0A$		540	1000	
		LP8340-5.0 $I_{OUT} = 800mA$		330	650	
		LP8340-5.0 $I_{OUT} = 1.0A$		420	800	
I_Q	Quiescent Current	$V_{IN} \leq 10V$		19	50	μA
	Minimum Load Current	$V_{IN} - V_{OUT} \leq 4V$			100	μA
I_{LIMIT}	Foldback Current Limit	$V_{IN} - V_{OUT} > 5V$		450		mA
		$V_{IN} - V_{OUT} < 4V$		1600		
	Ripple Rejection Ratio	$V_{IN} (dc) = V_{OUT} + 2V$ $V_{IN} (ac) = 1 V_{P-P} @ 120Hz$	48	55		dB

(1) All limits are specified by testing or statistical analysis.

(2) Typical Values represent the most likely parametric norm.

(3) Condition does not apply to input voltages below 2.7V since this is the minimum input operating voltage.

(4) Dropout voltage is measured by reducing V_{IN} until V_O drops 100mV from its normal value.

LP8340I Electrical Characteristics (continued)

Unless otherwise specified all limits ensured for $V_{IN} = V_{O+} + 1V$, $C_{IN} = C_{OUT} = 10\mu F$, $T_J = 25^\circ C$. **Boldface** limits apply over the full operating temperature range of $T_J = -40^\circ C$ to $125^\circ C$

Symbol	Parameter	Conditions	Min ⁽¹⁾	Typ ⁽²⁾	Max ⁽¹⁾	Units
T_{SD}	Thermal Shutdown Temp. Thermal Shutdown Hyst.			160 10		$^\circ C$
	ADJ Input Leakage Current	$V_{ADJ} = 1.5V$ or $0V$		± 0.01	± 100	nA
	V_{OUT} Leakage Current	LP8340-ADJ ADJ = OUT, $V_{OUT} = 2V$, $V_{IN} = 10V$			10	μA
		LP8340-1.8, $V_{OUT} = 2.5V$, $V_{IN} = 10V$			10	
		LP8340-2.5, $V_{OUT} = 3.5V$, $V_{IN} = 10V$			10	
		LP8340-3.3, $V_{OUT} = 4V$, $V_{IN} = 10V$			10	
		LP8340-5.0, $V_{OUT} = 6V$, $V_{IN} = 10V$			10	
e_n	Output Noise	10Hz to 10kHz, $R_L = 1k\Omega$, $C_{OUT} = 10\mu F$		250		μV_{rms}

Typical Performance Characteristics

Unless otherwise specified, $V_{IN} = V_O + 1.5V$, $C_{IN} = C_{OUT} = 10\mu F$ X7R ceramic, $T_J = 25^\circ C$

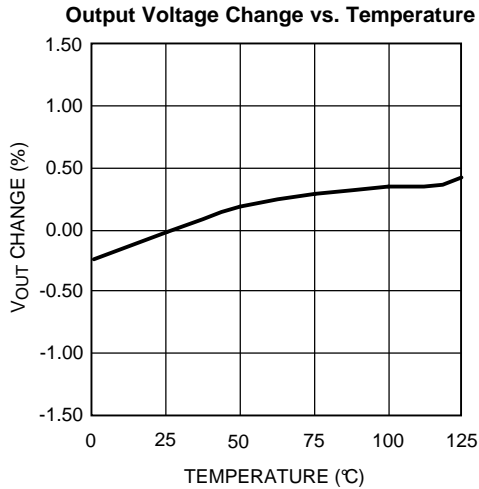

Figure 6.

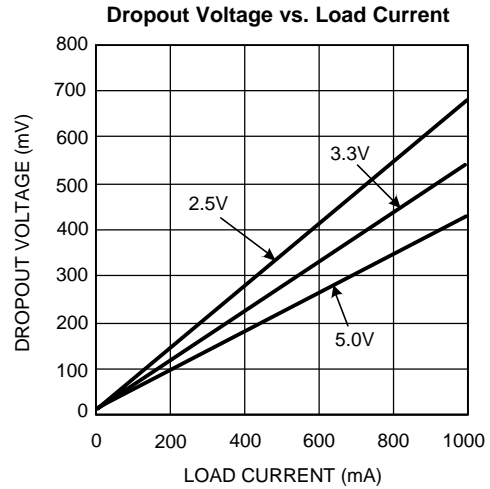

Figure 7.

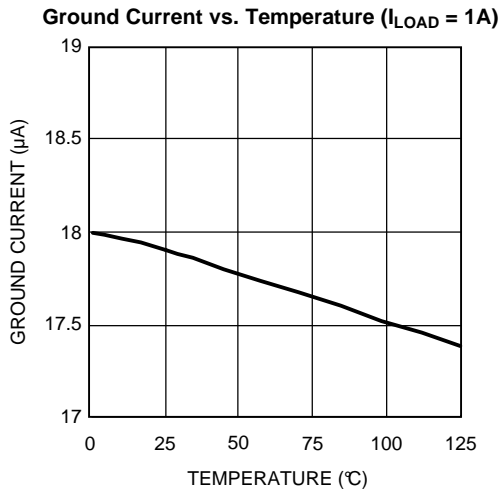

Figure 8.

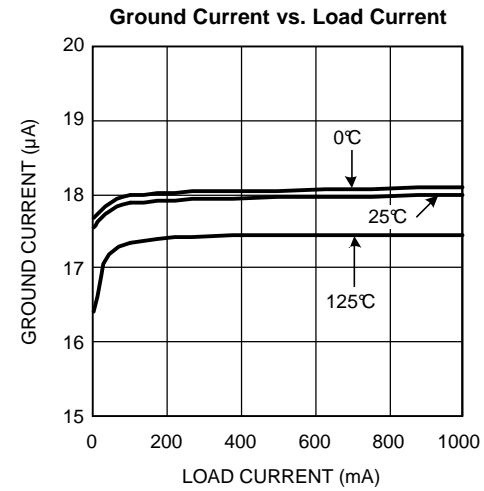

Figure 9.

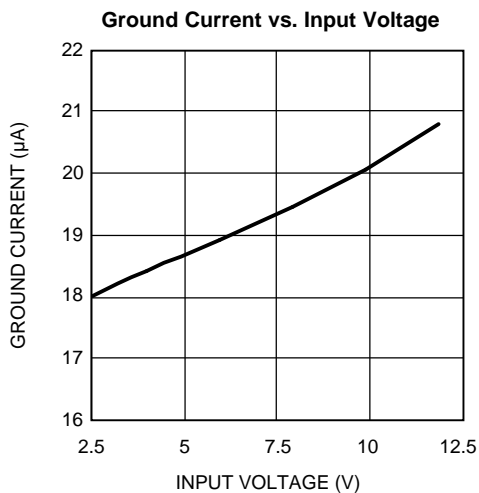

Figure 10.

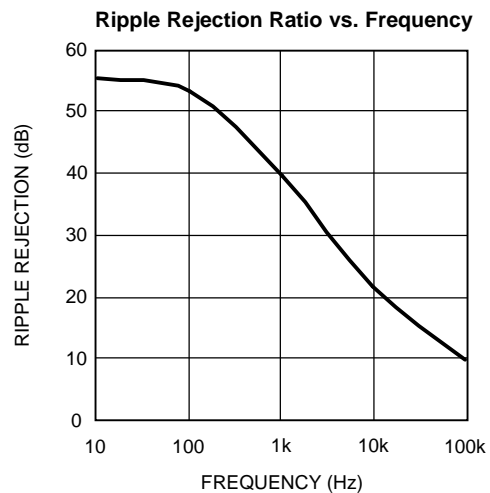

Figure 11.

Typical Performance Characteristics (continued)

Unless otherwise specified, $V_{IN} = V_O + 1.5V$, $C_{IN} = C_{OUT} = 10\mu F$ X7R ceramic, $T_J = 25^\circ C$

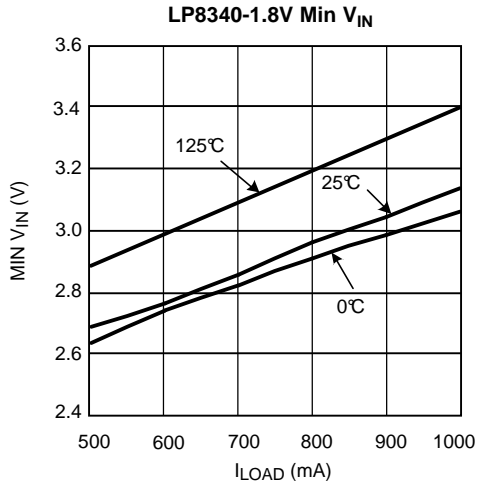

Figure 12.

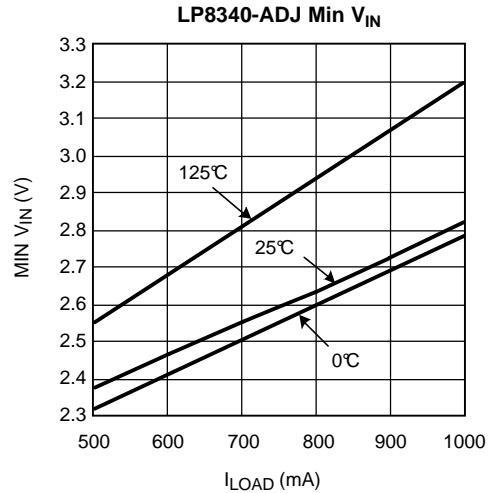

Figure 13.

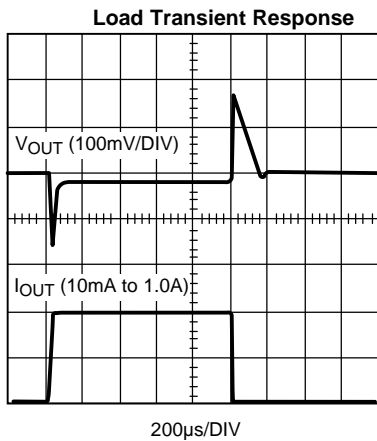

Figure 14.

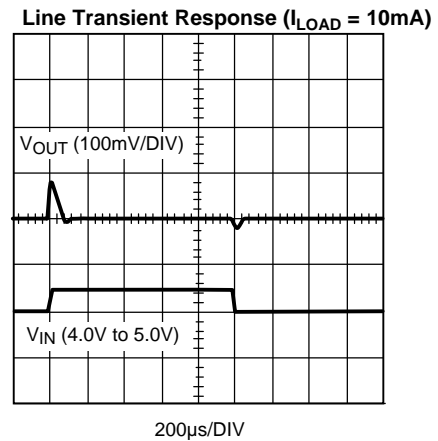

Figure 15.

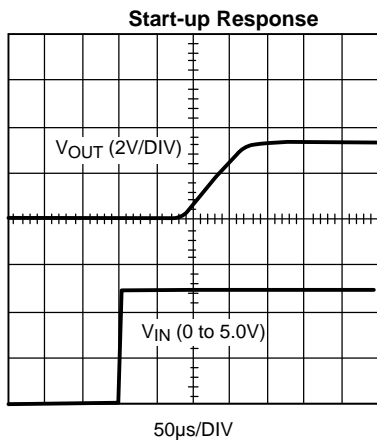

Figure 16.

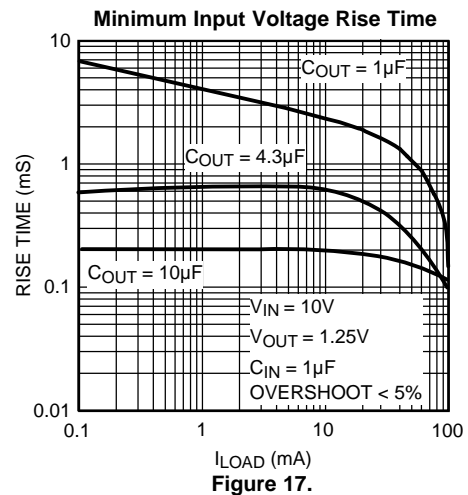

Figure 17.

Typical Performance Characteristics (continued)

Unless otherwise specified, $V_{IN} = V_O + 1.5V$, $C_{IN} = C_{OUT} = 10\mu F$ X7R ceramic, $T_J = 25^\circ C$

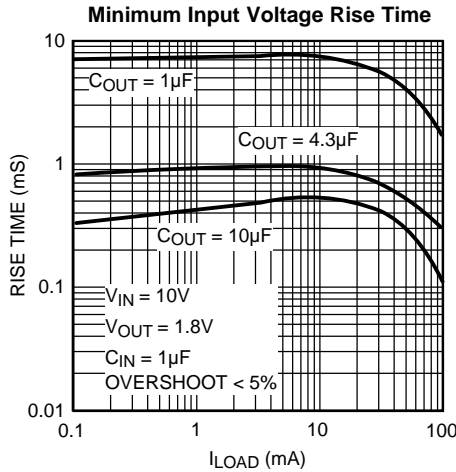

Figure 18.

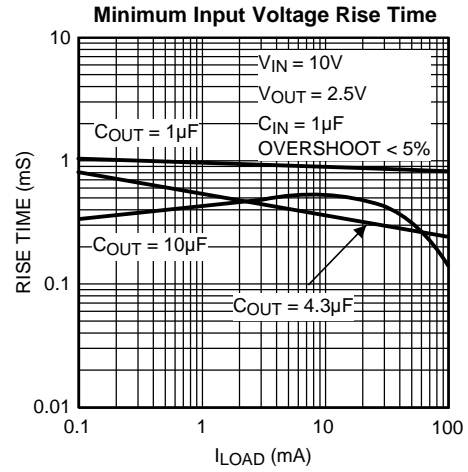

Figure 19.

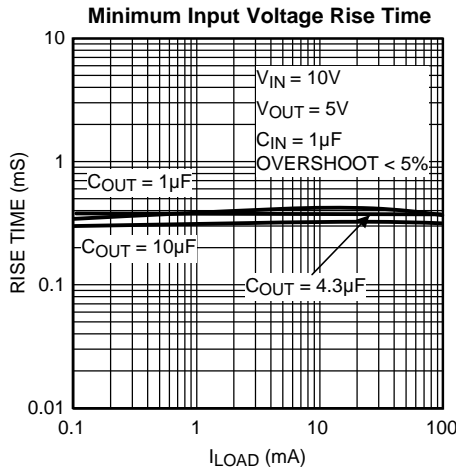

Figure 20.

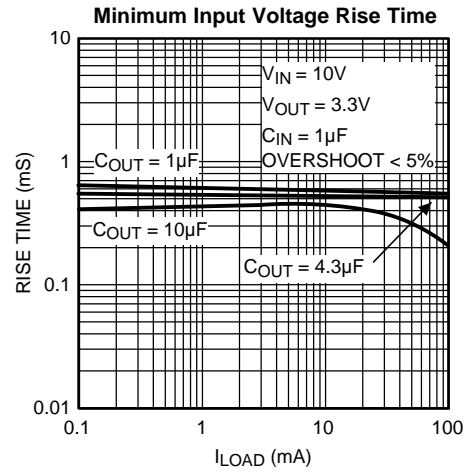

Figure 21.

APPLICATIONS SECTION

GENERAL INFORMATION

The LP8340 is a low-dropout, low quiescent current linear regulator. As shown in [Figure 22](#) it consists of a 1.25V reference, error amplifier, MOSFET driver, PMOS pass transistor and for the fixed output versions, an internal feedback network (R_1/R_2). In addition, the device is protected from overload by a thermal shutdown circuit and a foldback current limit circuit

The 1.25V reference is connected to the inverting input of the error amplifier. Regulation of the output voltage is achieved by means of negative feedback to the non-inverting input of the error amplifier. Feedback resistors R_1 and R_2 are either internal or external to the device, depending on whether it is a fixed voltage version or the adjustable version. The negative feedback and high open loop gain of the error amplifier cause the two inputs of the error amp to be virtually equal in voltage. If the output voltage changes due to load changes, the error amplifier and MOSFET driver provide the appropriate drive to the pass transistor to maintain the error amplifier's inputs as virtually equal.

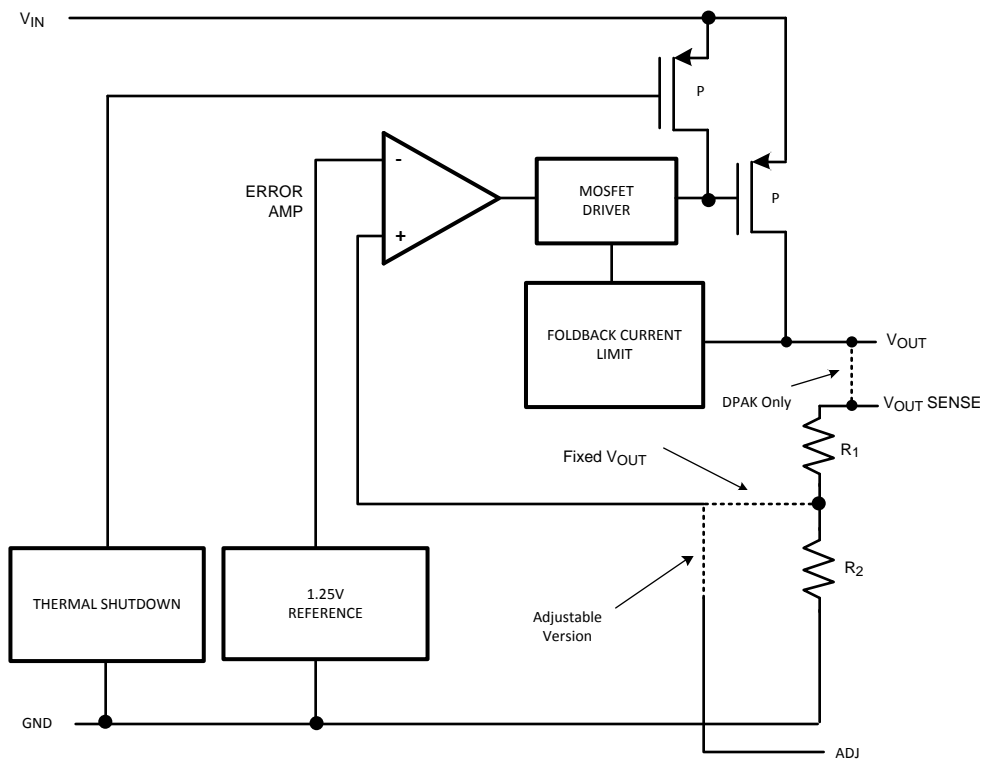

Figure 22. LP8340 Functional Block Diagram

EXTERNAL CAPACITOR

An Input capacitor of $1\mu\text{F}$ or greater is required between the LP8340 V_{IN} pin and ground. While $1\mu\text{F}$ will provide adequate bypassing of the V_{IN} supply larger values of input capacitor (i.e. $10\mu\text{F}$) can provide improved bypassing of power supply noise.

Stable operation can be achieved with an output capacitor of $1\mu\text{F}$ or greater, either ceramic X7R dielectric or aluminum/tantalum electrolytic. While the minimum capacitor value is $1\mu\text{F}$, the typical output capacitor values selected range from $1\mu\text{F}$ to $10\mu\text{F}$. The larger values provide improved load-transient response, power supply rejection and stability.

OUTPUT VOLTAGE SETTING (ADJ VERSION ONLY)

The output voltage is set according to the amount of negative feedback (Note that the pass transistor inverts the feedback signal). This feedback is determined by R_1 and R_2 with the resulting output voltage represented by the following equation:

$$V_O = V_{REF} \left[\frac{R_1}{R_2} + 1 \right] \quad (1)$$

Use the following equation to determine the values of R_1 and R_2 for a desired V_{OUT} ($R_2 = 100\text{k}\Omega$ is recommended).

$$R_1 = R_2 \left[\frac{V_O}{1.25\text{V}} - 1 \right] \quad (2)$$

MINIMUM LOAD CURRENT

A minimum load of $100\mu\text{A}$ is required for regulation and stability over the entire operating temperature range. If actual load current fall below $100\mu\text{A}$ it is recommended that a resistor of value $R_L = V_O/100\mu\text{A}$ be placed between V_O and ground.

START UP CONSIDERATIONS

Under certain operating conditions, overshoot of V_{OUT} at start-up can occur. The observed overshoot is a function of rise time of V_{IN} waveform, C_{OUT} , start-up load current, and $V_{IN}-V_{OUT}$ differential. The relationship between these conditions is shown in the Typical Performance Characteristics curves (Minimum Input Voltage Rise Time). V_{IN} rise times above the curve result in <5% overshoot.

Customers are encouraged to check the suitability of LP8340 in their specific application.

REVISION HISTORY

Changes from Revision C (April 2013) to Revision D	Page
• Changed layout of National Data Sheet to TI format	11

PACKAGING INFORMATION

Orderable Device	Status (1)	Package Type	Package Drawing	Pins	Package Qty	Eco Plan (2)	Lead/Ball Finish (6)	MSL Peak Temp (3)	Op Temp (°C)	Device Marking (4/5)	Samples
LP8340ILDY-ADJ/NOPB	ACTIVE	WSON	NGD	6	4500	Green (RoHS & no Sb/Br)	CU SN	Level-3-260C-168 HR	0 to 125	L078B	Samples

(1) The marketing status values are defined as follows:

ACTIVE: Product device recommended for new designs.

LIFEBUY: TI has announced that the device will be discontinued, and a lifetime-buy period is in effect.

NRND: Not recommended for new designs. Device is in production to support existing customers, but TI does not recommend using this part in a new design.

PREVIEW: Device has been announced but is not in production. Samples may or may not be available.

OBSELETE: TI has discontinued the production of the device.

(2) Eco Plan - The planned eco-friendly classification: Pb-Free (RoHS), Pb-Free (RoHS Exempt), or Green (RoHS & no Sb/Br) - please check <http://www.ti.com/productcontent> for the latest availability information and additional product content details.

TBD: The Pb-Free/Green conversion plan has not been defined.

Pb-Free (RoHS): TI's terms "Lead-Free" or "Pb-Free" mean semiconductor products that are compatible with the current RoHS requirements for all 6 substances, including the requirement that lead not exceed 0.1% by weight in homogeneous materials. Where designed to be soldered at high temperatures, TI Pb-Free products are suitable for use in specified lead-free processes.

Pb-Free (RoHS Exempt): This component has a RoHS exemption for either 1) lead-based flip-chip solder bumps used between the die and package, or 2) lead-based die adhesive used between the die and leadframe. The component is otherwise considered Pb-Free (RoHS compatible) as defined above.

Green (RoHS & no Sb/Br): TI defines "Green" to mean Pb-Free (RoHS compatible), and free of Bromine (Br) and Antimony (Sb) based flame retardants (Br or Sb do not exceed 0.1% by weight in homogeneous material)

(3) MSL, Peak Temp. - The Moisture Sensitivity Level rating according to the JEDEC industry standard classifications, and peak solder temperature.

(4) There may be additional marking, which relates to the logo, the lot trace code information, or the environmental category on the device.

(5) Multiple Device Markings will be inside parentheses. Only one Device Marking contained in parentheses and separated by a "-" will appear on a device. If a line is indented then it is a continuation of the previous line and the two combined represent the entire Device Marking for that device.

(6) Lead/Ball Finish - Orderable Devices may have multiple material finish options. Finish options are separated by a vertical ruled line. Lead/Ball Finish values may wrap to two lines if the finish value exceeds the maximum column width.

Important Information and Disclaimer:The information provided on this page represents TI's knowledge and belief as of the date that it is provided. TI bases its knowledge and belief on information provided by third parties, and makes no representation or warranty as to the accuracy of such information. Efforts are underway to better integrate information from third parties. TI has taken and continues to take reasonable steps to provide representative and accurate information but may not have conducted destructive testing or chemical analysis on incoming materials and chemicals. TI and TI suppliers consider certain information to be proprietary, and thus CAS numbers and other limited information may not be available for release.

In no event shall TI's liability arising out of such information exceed the total purchase price of the TI part(s) at issue in this document sold by TI to Customer on an annual basis.

TAPE AND REEL INFORMATION



QUADRANT ASSIGNMENTS FOR PIN 1 ORIENTATION IN TAPE



*All dimensions are nominal

Device	Package Type	Package Drawing	Pins	SPQ	Reel Diameter (mm)	Reel Width W1 (mm)	A0 (mm)	B0 (mm)	K0 (mm)	P1 (mm)	W (mm)	Pin1 Quadrant
LP8340ILDJ-ADJ/NOPB	WSON	NGD	6	4500	330.0	12.4	3.6	3.2	1.0	8.0	12.0	Q1

TAPE AND REEL BOX DIMENSIONS



*All dimensions are nominal

Device	Package Type	Package Drawing	Pins	SPQ	Length (mm)	Width (mm)	Height (mm)
LP8340ILDJ-ADJ/NOPB	WSON	NGD	6	4500	367.0	367.0	35.0

NGD0006A

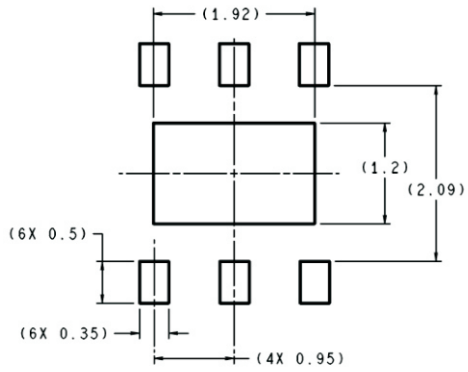

RECOMMENDED LAND PATTERN
1:1 RATIO WITH PKG SOLDER PADS

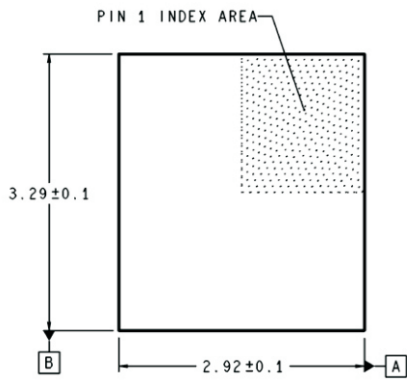

DIMENSIONS ARE IN MILLIMETERS

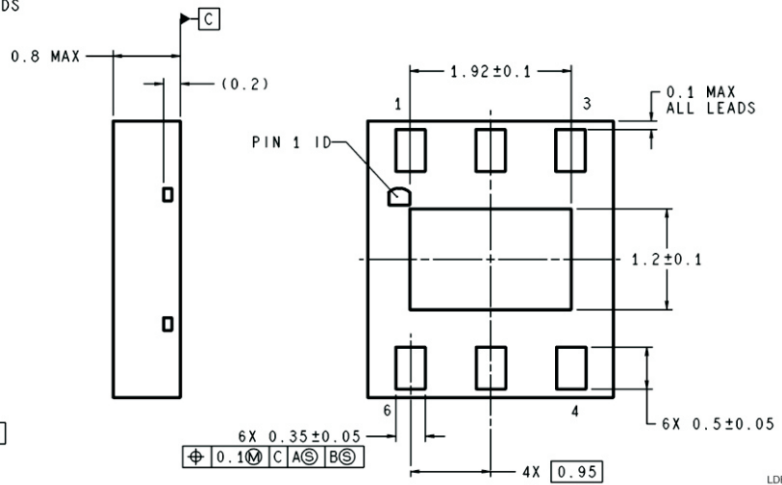

LDE06A (Rev A)

IMPORTANT NOTICE

Texas Instruments Incorporated and its subsidiaries (TI) reserve the right to make corrections, enhancements, improvements and other changes to its semiconductor products and services per JESD46, latest issue, and to discontinue any product or service per JESD48, latest issue. Buyers should obtain the latest relevant information before placing orders and should verify that such information is current and complete. All semiconductor products (also referred to herein as "components") are sold subject to TI's terms and conditions of sale supplied at the time of order acknowledgment.

TI warrants performance of its components to the specifications applicable at the time of sale, in accordance with the warranty in TI's terms and conditions of sale of semiconductor products. Testing and other quality control techniques are used to the extent TI deems necessary to support this warranty. Except where mandated by applicable law, testing of all parameters of each component is not necessarily performed.

TI assumes no liability for applications assistance or the design of Buyers' products. Buyers are responsible for their products and applications using TI components. To minimize the risks associated with Buyers' products and applications, Buyers should provide adequate design and operating safeguards.

TI does not warrant or represent that any license, either express or implied, is granted under any patent right, copyright, mask work right, or other intellectual property right relating to any combination, machine, or process in which TI components or services are used. Information published by TI regarding third-party products or services does not constitute a license to use such products or services or a warranty or endorsement thereof. Use of such information may require a license from a third party under the patents or other intellectual property of the third party, or a license from TI under the patents or other intellectual property of TI.

Reproduction of significant portions of TI information in TI data books or data sheets is permissible only if reproduction is without alteration and is accompanied by all associated warranties, conditions, limitations, and notices. TI is not responsible or liable for such altered documentation. Information of third parties may be subject to additional restrictions.

Resale of TI components or services with statements different from or beyond the parameters stated by TI for that component or service voids all express and any implied warranties for the associated TI component or service and is an unfair and deceptive business practice. TI is not responsible or liable for any such statements.

Buyer acknowledges and agrees that it is solely responsible for compliance with all legal, regulatory and safety-related requirements concerning its products, and any use of TI components in its applications, notwithstanding any applications-related information or support that may be provided by TI. Buyer represents and agrees that it has all the necessary expertise to create and implement safeguards which anticipate dangerous consequences of failures, monitor failures and their consequences, lessen the likelihood of failures that might cause harm and take appropriate remedial actions. Buyer will fully indemnify TI and its representatives against any damages arising out of the use of any TI components in safety-critical applications.

In some cases, TI components may be promoted specifically to facilitate safety-related applications. With such components, TI's goal is to help enable customers to design and create their own end-product solutions that meet applicable functional safety standards and requirements. Nonetheless, such components are subject to these terms.

No TI components are authorized for use in FDA Class III (or similar life-critical medical equipment) unless authorized officers of the parties have executed a special agreement specifically governing such use.

Only those TI components which TI has specifically designated as military grade or "enhanced plastic" are designed and intended for use in military/aerospace applications or environments. Buyer acknowledges and agrees that any military or aerospace use of TI components which have **not** been so designated is solely at the Buyer's risk, and that Buyer is solely responsible for compliance with all legal and regulatory requirements in connection with such use.

TI has specifically designated certain components as meeting ISO/TS16949 requirements, mainly for automotive use. In any case of use of non-designated products, TI will not be responsible for any failure to meet ISO/TS16949.

Products

Audio	www.ti.com/audio
Amplifiers	amplifier.ti.com
Data Converters	dataconverter.ti.com
DLP® Products	www.dlp.com
DSP	dsp.ti.com
Clocks and Timers	www.ti.com/clocks
Interface	interface.ti.com
Logic	logic.ti.com
Power Mgmt	power.ti.com
Microcontrollers	microcontroller.ti.com
RFID	www.ti-rfid.com
OMAP Applications Processors	www.ti.com/omap
Wireless Connectivity	www.ti.com/wirelessconnectivity

Applications

Automotive and Transportation	www.ti.com/automotive
Communications and Telecom	www.ti.com/communications
Computers and Peripherals	www.ti.com/computers
Consumer Electronics	www.ti.com/consumer-apps
Energy and Lighting	www.ti.com/energy
Industrial	www.ti.com/industrial
Medical	www.ti.com/medical
Security	www.ti.com/security
Space, Avionics and Defense	www.ti.com/space-avionics-defense
Video and Imaging	www.ti.com/video

TI E2E Community

e2e.ti.com

Looking for pricing, stock, or lifecycle information?

Click below to explore more details on WIN SOURCE:

 [View LP8340CLD-2.5/NOPB on WIN SOURCE](#)

 [Texas Instruments](#) Information

Optimize Your Supply Chain with WIN SOURCE Solutions

-  Global Sourcing Solution
-  Obsolete Management
-  Cost Control Management
-  Shortage Management
-  Alternative Solution
-  Excess Inventory Management