



**THE DATASHEET OF  
LPV531MKX/NOPB**



# LPV531 Programmable Micropower CMOS Input, Rail-to-Rail Output Operational Amplifier

Check for Samples: [LPV531](#)

## FEATURES

- (Typical 5V Supply, unless otherwise Noted.)
- Supply Voltage 2.7V to 5.5V
- Dynamic Power Mode Setting
- Continuously Programmable Supply Current
  - Range 5  $\mu$ A to 425  $\mu$ A
- Continuously Programmable Bandwidth
  - Range 73 kHz to 4.6 MHz
- Input Common Mode Voltage Range  $-0.3$ V to 3.8V
- CMRR 95 dB
- Rail-to-Rail Output Voltage Swing
- Input Offset Voltage 1 mV

## APPLICATIONS

- AC Coupled Circuits
- Portable Instrumentation
- Active Filters

## Typical Application

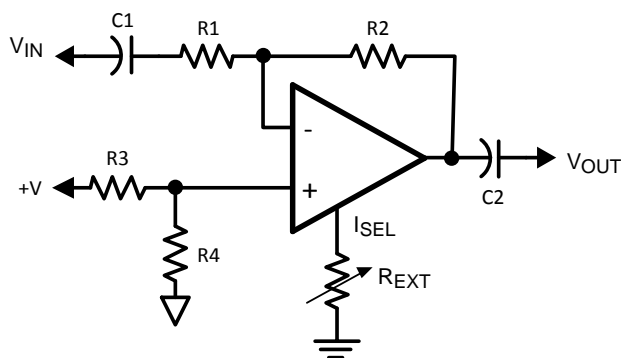

Figure 1. AC Coupled Application

## DESCRIPTION

The LPV531 is an extremely versatile operational amplifier. A single external resistor gives the system designer the ability to define the quiescent current, gain bandwidth product and output short circuit current. This innovative feature gives the system designer a method to dynamically switch the power level to optimize the performance of the op amp and meet the system design requirements.

The LPV531 can be tailored to a wide variety of applications. It offers the system designer the ability to dynamically trade off supply current for bandwidth by adjusting the current drawn from the  $I_{SEL}$  pin using a DAC or switching in different value resistors in series with the  $I_{SEL}$  pin. The LPV531 is capable of operating from 73 kHz, consuming only 5  $\mu$ A, to as fast as 4.6 MHz, consuming only 425  $\mu$ A. The input offset voltage is relatively independent and therefore is not significantly affected by the chosen power level.

Utilizing a CMOS input stage, the LPV531 achieves an input bias current of 50 fA and a common mode input voltage which extends from the negative rail to within 1.2V of the positive supply. The LPV531's rail-to-rail class AB output stage enables this op amp to offer maximum dynamic range at low supply voltage.

Offered in the space saving 6-pin SOT package, the LPV531 is ideal for use in handheld electronics and portable applications. The LPV531 is manufactured using TI's advanced VIP50 process.

A fixed supply current/gain bandwidth is available upon request.



Please be aware that an important notice concerning availability, standard warranty, and use in critical applications of Texas Instruments semiconductor products and disclaimers thereto appears at the end of this data sheet.

All trademarks are the property of their respective owners.



These devices have limited built-in ESD protection. The leads should be shorted together or the device placed in conductive foam during storage or handling to prevent electrostatic damage to the MOS gates.

### Absolute Maximum Ratings <sup>(1)(2)</sup>

ESD Tolerance <sup>(3)</sup>	
Human Body Model	2000V
Machine Model	200V
V <sub>IN</sub> Differential	±2V
Supply Voltage (V <sup>+</sup> - V <sup>-</sup> )	6V
Storage Temperature Range	-65°C to +150°C
Junction Temperature <sup>(4)</sup>	+150°C
Soldering Information	
Infrared or Convection (20 sec)	235°C
Wave Soldering Lead Temp. (10 sec)	260°C

- (1) Absolute Maximum Ratings indicate limits beyond which damage to the device may occur. Operating Ratings indicate conditions for which the device is intended to be functional, but specific performance is not ensured. For ensured specifications and the test conditions, see the Electrical Characteristics Tables.
- (2) If Military/Aerospace specified devices are required, please contact the Texas Instruments Sales Office/ Distributors for availability and specifications.
- (3) Human Body Model is 1.5 kΩ in series with 100 pF. Machine Model is 0Ω in series with 200 pF.
- (4) Typical values represent the most likely parametric norm.

### Operating Ratings <sup>(1)</sup>

Operating Temperature Range	-40°C to +85°C
Supply Voltage (V <sup>+</sup> - V <sup>-</sup> )	2.7V to 5.5V
Package Thermal Resistance (θ <sub>JA</sub> ) <sup>(2)</sup>	
6-Pin SOT	171°C/W

- (1) Absolute Maximum Ratings indicate limits beyond which damage to the device may occur. Operating Ratings indicate conditions for which the device is intended to be functional, but specific performance is not ensured. For ensured specifications and the test conditions, see the Electrical Characteristics Tables.
- (2) The maximum power dissipation is a function of T<sub>J(MAX)</sub>, θ<sub>JA</sub>, and T<sub>A</sub>. The maximum allowable power dissipation at any ambient temperature is P<sub>D</sub> = (T<sub>J(MAX)</sub> - T<sub>A</sub>) / θ<sub>JA</sub>. All numbers apply for packages soldered directly onto a PC board.

## 5V Full Power Mode Electrical Characteristics

Unless otherwise specified, all limits are ensured for  $T_J = 25^\circ\text{C}$ ,  $V^+ = 5\text{V}$ ,  $V^- = 0\text{V}$ ,  $V_{\text{CM}} = V_O = V^+/2$ ,  $I_{\text{SEL}}$  pin connected to  $V^-$ ,  $R_L = 100\text{ k}\Omega$ . **Boldface** limits apply at the temperature extremes.

Symbol	Parameter	Conditions	Min <sup>(1)</sup>	Typ <sup>(2)</sup>	Max <sup>(1)</sup>	Units
$V_{\text{OS}}$	Input Offset Voltage			$\pm 1$	$\pm 4.5$ <b><math>\pm 5</math></b>	mV
$\Delta V_{\text{OS}}$	Input Offset Voltage Difference	( $V_{\text{OS}}$ in Full Power Mode) – ( $V_{\text{OS}}$ in Low Power Mode)		$\pm 0.1$	$\pm 2$	mV
TC $V_{\text{OS}}$	Input Offset Average Drift	<sup>(3)</sup>		$\pm 2$		$\mu\text{V}/^\circ\text{C}$
$I_B$	Input Bias Current	<sup>(4)</sup>		.05	$\pm 10$ <b><math>\pm 100</math></b>	pA
CMRR	Common Mode Rejection Ratio	$V_{\text{CM}}$ Stepped from 0V to 3.5V	72 <b>68</b>	95		dB
PSRR	Power Supply Rejection Ratio	$V^+ = 2.7\text{V}$ to 5.5V $V_{\text{CM}} = 1\text{V}$	74 <b>70</b>	90		dB
CMVR	Input Common Mode Voltage Range	CMRR $\geq 50$ dB	-0.3		3.8	V
$A_{\text{VOL}}$	Large Signal Voltage Gain	$V_O = 0.5\text{V}$ to 4.5V $R_L = 1\text{ k}\Omega$ to $V^+/2$	87 <b>84</b>	96		dB
		$V_O = 0.5\text{V}$ to 4.5V $R_L = 10\text{ k}\Omega$ to $V^+/2$	104 <b>100</b>	114		
		$V_O = 0.5\text{V}$ to 4.5V $R_L = 100\text{ k}\Omega$ , to $V^+/2$	108 <b>104</b>	128		
$V_O$	Output Swing High	$R_L = 1\text{ k}\Omega$ to $V^+/2$		120	180 <b>195</b>	mV from $V^+$
		$R_L = 10\text{ k}\Omega$ to $V^+/2$		55	80 <b>85</b>	
		$R_L = 100\text{ k}\Omega$ to $V^+/2$		30	50 <b>60</b>	
	Output Swing Low	$R_L = 1\text{ k}\Omega$ to $V^+/2$		160	210 <b>230</b>	mV
		$R_L = 10\text{ k}\Omega$ to $V^+/2$		105	120 <b>135</b>	
		$R_L = 100\text{ k}\Omega$ to $V^+/2$		95	120 <b>135</b>	
$I_{\text{SC}}$	Output Short Circuit Current <sup>(5)</sup>	Sourcing, $V_O = 2.5\text{V}$ $V_{\text{ID}} = 100\text{ mV}$		-15	-8 <b>-3</b>	mA
		Sinking, $V_O = 2.5\text{V}$ $V_{\text{ID}} = -100\text{ mV}$	13 <b>10</b>	24		
$I_S$	Supply Current			425	530 <b>650</b>	$\mu\text{A}$
SR	Slew Rate <sup>(6)</sup>	$A_V = +1$ , $V_{\text{IN}} = 0.5\text{V}$ to 3.5V $C_L = 15\text{ pF}$	1.55 <b>1</b>	2.5		V/ $\mu\text{s}$
GBW	Gain Bandwidth Product	$C_L = 20\text{ pF}$		4.6		MHz
$e_n$	Input-Referred Voltage Noise	$f = 100\text{ kHz}$		20		$\text{nV}/\sqrt{\text{Hz}}$
		$f = 1\text{ kHz}$		28		
$i_n$	Input-Referred Current Noise	$f = 1\text{ kHz}$		6		$\text{fA}/\sqrt{\text{Hz}}$

(1) All limits are specified by testing or statistical analysis.

(2) Typical values represent the most likely parametric norm.

(3) Offset voltage average drift is determined by dividing the change in  $V_{\text{OS}}$  at temperature extremes into the total temperature change.

(4) Specified by design.

(5) Continuous short circuit operation at elevated ambient temperature can result in exceeding the maximum allowed junction temperature of  $150^\circ\text{C}$ .

(6) Slew rate is the slower of the rising or falling slew rates.

## 5V Mid-Power Mode Electrical Characteristics

Unless otherwise specified, all limits are ensured for  $T_J = 25^\circ\text{C}$ ,  $V^+ = 5\text{V}$ ,  $V^- = 0\text{V}$ ,  $V_{\text{CM}} = V_O = V^+/2$ ,  $I_{\text{SEL}}$  pin connected to  $V^-$  through 100 k $\Omega$  resistor,  $R_L = 100\text{ k}\Omega$ . **Boldface** limits apply at the temperature extremes.

Symbol	Parameter	Conditions	Min <sup>(1)</sup>	Typ <sup>(2)</sup>	Max <sup>(1)</sup>	Units
$V_{\text{OS}}$	Input Offset Voltage			$\pm 1$	$\pm 4.5$ <b><math>\pm 5</math></b>	mV
$\Delta V_{\text{OS}}$	Input Offset Voltage Difference	( $V_{\text{OS}}$ in Full Power Mode) – ( $V_{\text{OS}}$ in Low Power Mode)		$\pm 0.1$	$\pm 2$	mV
TC $V_{\text{OS}}$	Input Offset Average Drift	<sup>(3)</sup>		$\pm 2$		$\mu\text{V}/^\circ\text{C}$
$I_B$	Input Bias Current	<sup>(4)</sup>		.05	$\pm 10$ <b><math>\pm 100</math></b>	pA
CMRR	Common Mode Rejection Ratio	$V_{\text{CM}}$ Stepped from 0V to 3.5V	72 <b>68</b>	92		dB
PSRR	Power Supply Rejection Ratio	$V^+ = 2.7\text{V}$ to 5.5V	72 <b>68</b>	88		dB
CMVR	Input Common Mode Voltage Range	CMRR $\geq 50$ dB	-0.3		3.8	V
$A_{\text{VOL}}$	Large Signal Voltage Gain	$V_O = 0.5\text{V}$ to 4.5V $R_L = 10\text{ k}\Omega$ to $V^+/2$	86 <b>82</b>	96		dB
		$V_O = 0.5\text{V}$ to 4.5V $R_L = 100\text{ k}\Omega$ to $V^+/2$	100 <b>98</b>	114		
$V_O$	Output Swing High	$R_L = 10\text{ k}\Omega$ to $V^+/2$		115	160 <b>175</b>	mV from $V^+$
		$R_L = 100\text{ k}\Omega$ to $V^+/2$		65	110 <b>120</b>	
	Output Swing Low	$R_L = 10\text{ k}\Omega$ to $V^+/2$		150	165 <b>180</b>	mV
		$R_L = 100\text{ k}\Omega$ to $V^+/2$		105	120 <b>135</b>	
$I_{\text{SC}}$	Output Short Circuit Current <sup>(5)</sup>	Sourcing, $V_O = 2.5\text{V}$ $V_{\text{ID}} = 100\text{ mV}$		-4	-1.5 <b>-1</b>	mA
		Sinking, $V_O = 2.5\text{V}$ $V_{\text{ID}} = -100\text{ mV}$	1.5 <b>1</b>	4		
$I_S$	Supply Current			42	55 <b>62</b>	$\mu\text{A}$
SR	Slew Rate <sup>(6)</sup>	$A_V = +1$ , $V_{\text{IN}} = 0.5\text{V}$ to 3.5V	180 <b>100</b>	250		V/ms
GBW	Gain Bandwidth Product	$C_L = 20\text{ pF}$		625		kHz
$e_n$	Input-Referred Voltage Noise	$f = 100\text{ kHz}$		55		$\text{nV}/\sqrt{\text{Hz}}$
		$f = 1\text{ kHz}$		60		
$i_n$	Input-Referred Current Noise	$f = 1\text{ kHz}$		6		$\text{fA}/\sqrt{\text{Hz}}$

(1) All limits are specified by testing or statistical analysis.

(2) Typical values represent the most likely parametric norm.

(3) Offset voltage average drift is determined by dividing the change in  $V_{\text{OS}}$  at temperature extremes into the total temperature change.

(4) Specified by design.

(5) Continuous short circuit operation at elevated ambient temperature can result in exceeding the maximum allowed junction temperature of  $150^\circ\text{C}$ .

(6) Slew rate is the slower of the rising or falling slew rates.

## 5V Low Power Mode Electrical Characteristics

Unless otherwise specified, all limits are ensured for  $T_J = 25^\circ\text{C}$ ,  $V^+ = 5\text{V}$ ,  $V^- = 0\text{V}$ ,  $V_{\text{CM}} = V_O = V^+/2$ ,  $I_{\text{SEL}}$  connected to  $V^-$  through 1 M $\Omega$  resistor,  $R_L = 100\text{ k}\Omega$ . **Boldface** limits apply at the temperature extremes.

Symbol	Parameter	Conditions	Min <sup>(1)</sup>	Typ <sup>(2)</sup>	Max <sup>(1)</sup>	Units
$V_{\text{OS}}$	Input Offset Voltage			$\pm 1$	$\pm 4.5$ <b><math>\pm 5</math></b>	mV
$\Delta V_{\text{OS}}$	Input Offset Voltage Difference	( $V_{\text{OS}}$ in Full Power Mode) – ( $V_{\text{OS}}$ in Low Power Mode)		$\pm 0.1$	$\pm 2$	mV
TC $V_{\text{OS}}$	Input Offset Average Drift	<sup>(3)</sup>		$\pm 2$		$\mu\text{V}/^\circ\text{C}$
$I_B$	Input Bias Current	<sup>(4)</sup>		.05	$\pm 10$ <b><math>\pm 100</math></b>	pA
CMRR	Common Mode Rejection Ratio	$V_{\text{CM}}$ Stepped from 0V to 3.5V	72 <b>68</b>	90		dB
PSRR	Power Supply Rejection Ratio	$V^+ = 2.7\text{V}$ to 5.5V	72 <b>68</b>	85		dB
CMVR	Input Common-Mode Voltage Range	CMRR $\geq 50$ dB	-0.3		3.8	V
$A_{\text{VOL}}$	Large Signal Voltage Gain	$V_O = 0.5\text{V}$ to 4.5V $R_L = 10\text{ k}\Omega$ to $V^+/2$		90		dB
		$V_O = 0.5\text{V}$ to 4.5V $R_L = 100\text{ k}\Omega$ to $V^+/2$	80 <b>78</b>	100		
$V_O$	Output Swing High	$R_L = 10\text{ k}\Omega$ to $V^+/2$		175	400 <b>1600</b>	mV from $V^+$
		$R_L = 100\text{ k}\Omega$ to $V^+/2$		115	200 <b>230</b>	
	Output Swing Low	$R_L = 10\text{ k}\Omega$ to $V^+/2$		250	1200 <b>1800</b>	mV
		$R_L = 100\text{ k}\Omega$ to $V^+/2$		150	165 <b>180</b>	
$I_{\text{SC}}$	Output Short Circuit Current <sup>(5)</sup>	Sourcing, $V_O = 2.5\text{V}$ $V_{\text{ID}} = 100\text{ mV}$		-400	-100 <b>-35</b>	$\mu\text{A}$
		Sinking, $V_O = 2.5\text{V}$ $V_{\text{ID}} = -100\text{ mV}$	80 <b>35</b>	300		
$I_S$	Supply Current			5	7 <b>8</b>	$\mu\text{A}$
SR	Slew Rate <sup>(6)</sup>	$A_V = +1$ , $V_{\text{IN}} = 0.5\text{V}$ to 3.5V	10 <b>8</b>	28		V/ms
GBW	Gain Bandwidth Product	$C_L = 20\text{ pF}$		73		kHz
$e_n$	Input-Referred Voltage Noise	$f = 1\text{ kHz}$		200		$\text{nV}/\sqrt{\text{Hz}}$
$i_n$	Input-Referred Current Noise	$f = 1\text{ kHz}$		60		$\text{fA}/\sqrt{\text{Hz}}$

(1) All limits are specified by testing or statistical analysis.

(2) Typical values represent the most likely parametric norm.

(3) Offset voltage average drift is determined by dividing the change in  $V_{\text{OS}}$  at temperature extremes into the total temperature change.

(4) Specified by design.

(5) Continuous short circuit operation at elevated ambient temperature can result in exceeding the maximum allowed junction temperature of  $150^\circ\text{C}$ .

(6) Slew rate is the slower of the rising or falling slew rates.

### Power Select Electrical Characteristics

Unless otherwise specified, all limits are ensured for  $T_J = 25^\circ\text{C}$ ,  $V^+ = 5\text{V}$ ,  $V^- = 0\text{V}$ ,  $V_{\text{CM}} = V_O = V^+/2$ ,  $R_L = 100\text{ k}\Omega$ . **Boldface** limits apply at the temperature extremes.

Symbol	Parameter	Conditions	Min <sup>(1)</sup>	Typ <sup>(2)</sup>	Max <sup>(1)</sup>	Units
$t_{\text{LF}}$	Time from Low Power Mode to Full Power Mode			210		ns
$t_{\text{FL}}$	Time from Full Power Mode to Low Power Mode			500		ns
$V_{\text{REXT}}$	Voltage @ $I_{\text{SEL}}$ Pin	$I_{\text{SEL}}$ Pin Left Open	100	110	125	mV
$R_{\text{INT}}$			9	11	14.5	k $\Omega$

- (1) All limits are specified by testing or statistical analysis.
- (2) Typical values represent the most likely parametric norm.

### Connection Diagram

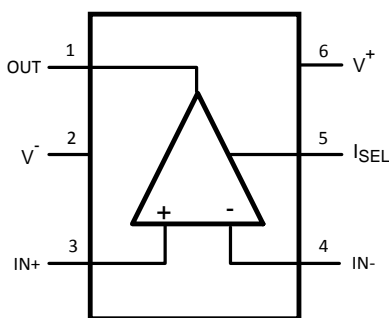

Figure 2. 6-Pin SOT – Top View  
See Package Number DDC

### Typical Performance Characteristics

Unless otherwise specified,  $V^+ = 5V$ ,  $T_J = 25^\circ C$ . For Full Power Mode the  $I_{SEL}$  pin is connected to  $V^-$ ; for Mid-Power Mode the  $I_{SEL}$  pin is connected to  $V^-$  through a 100 k $\Omega$  resistor; for Low Power Mode the  $I_{SEL}$  pin is connected to  $V^-$  through a 1 M $\Omega$  resistor.

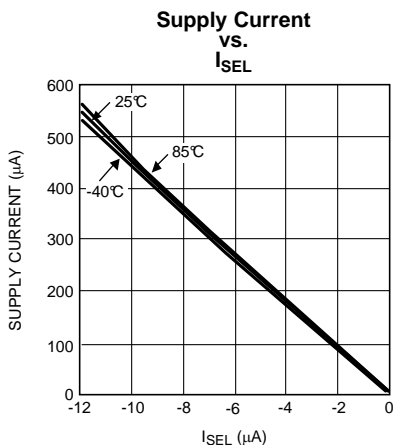

Figure 3.

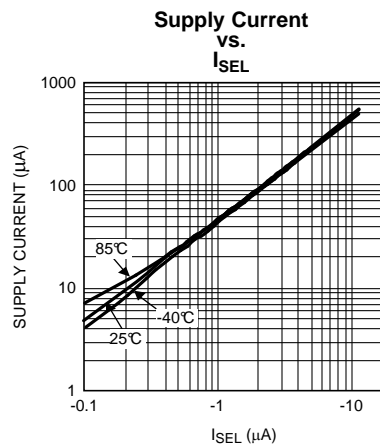

Figure 4.

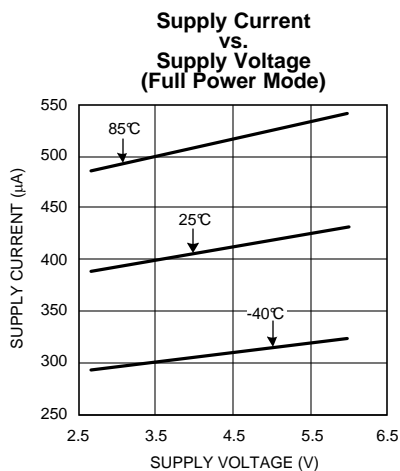

Figure 5.

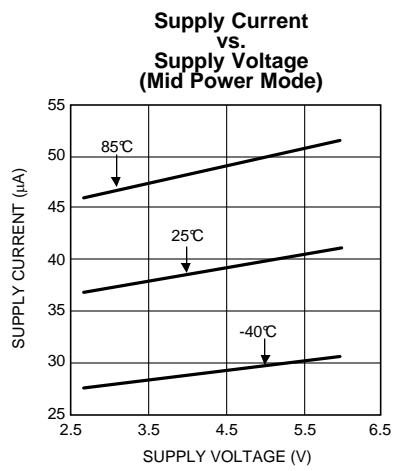

Figure 6.

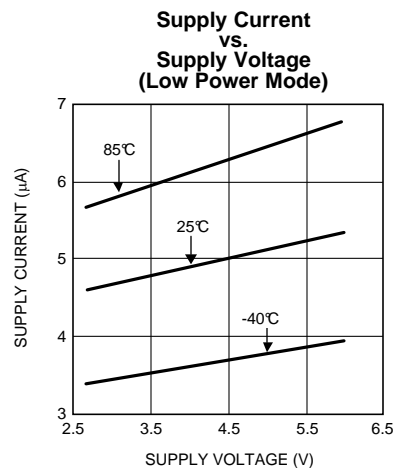

Figure 7.

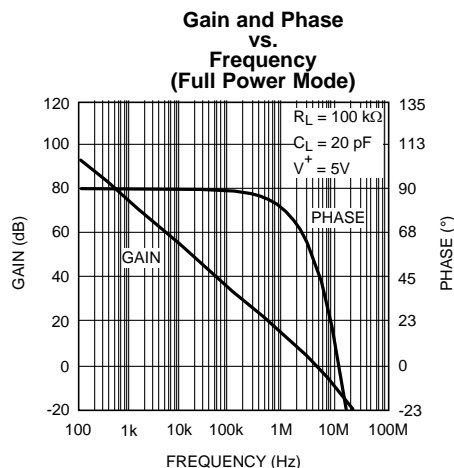

Figure 8.

### Typical Performance Characteristics (continued)

Unless otherwise specified,  $V^+ = 5V$ ,  $T_J = 25^\circ C$ . For Full Power Mode the  $I_{SEL}$  pin is connected to  $V^-$ ; for Mid-Power Mode the  $I_{SEL}$  pin is connected to  $V^-$  through a  $100\text{ k}\Omega$  resistor; for Low Power Mode the  $I_{SEL}$  pin is connected to  $V^-$  through a  $1\text{ M}\Omega$  resistor.

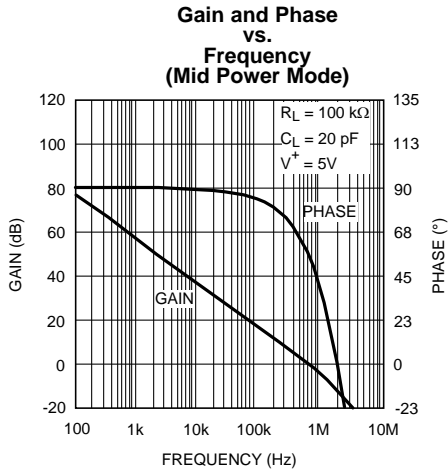

Figure 9.

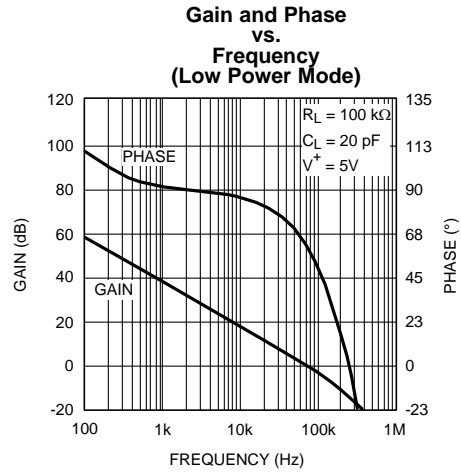

Figure 10.

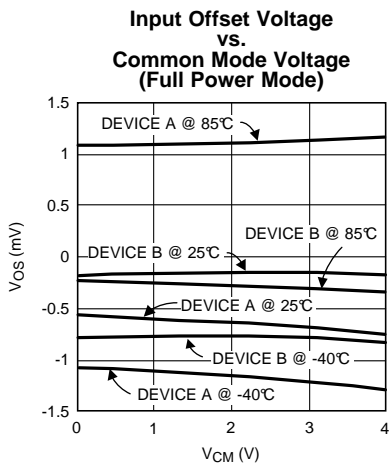

Figure 11.

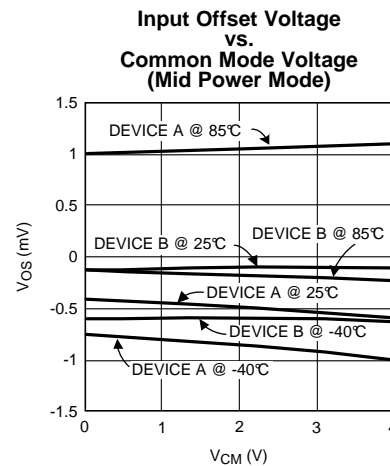

Figure 12.

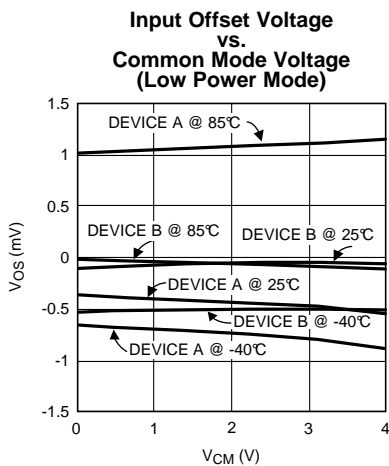

Figure 13.

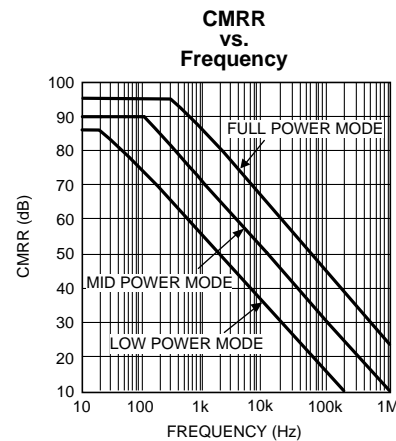

Figure 14.

### Typical Performance Characteristics (continued)

Unless otherwise specified,  $V^+ = 5V$ ,  $T_J = 25^\circ C$ . For Full Power Mode the  $I_{SEL}$  pin is connected to  $V^-$ ; for Mid-Power Mode the  $I_{SEL}$  pin is connected to  $V^-$  through a 100 k $\Omega$  resistor; for Low Power Mode the  $I_{SEL}$  pin is connected to  $V^-$  through a 1 M $\Omega$  resistor.

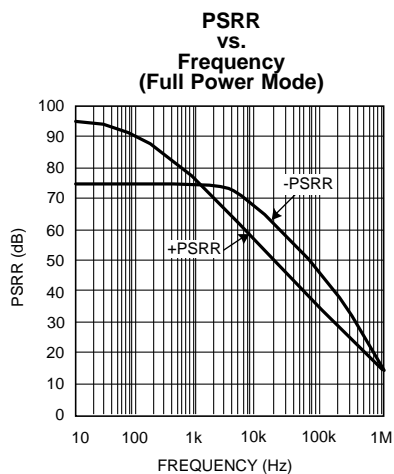

Figure 15.

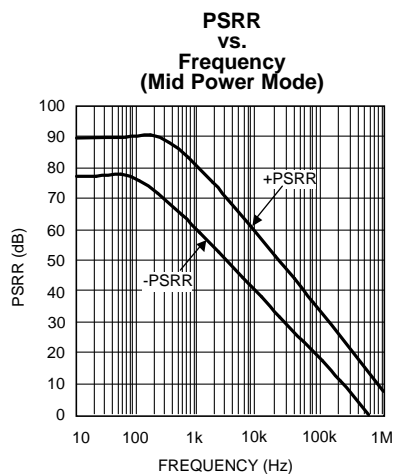

Figure 16.

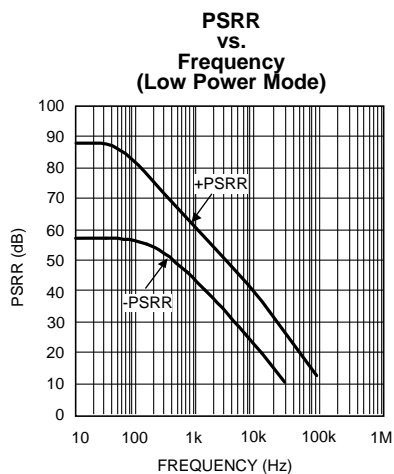

Figure 17.

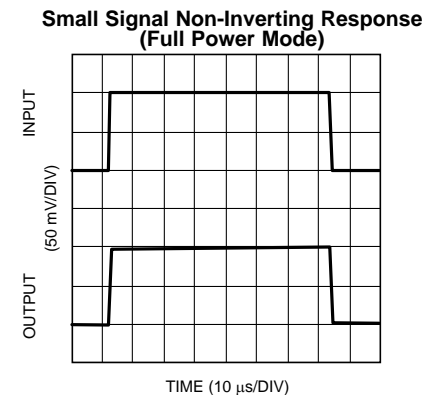

Figure 18.

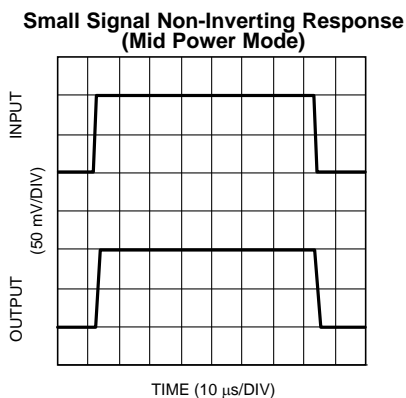

Figure 19.

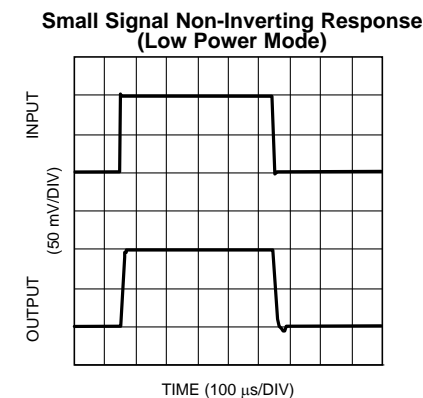

Figure 20.

### Typical Performance Characteristics (continued)

Unless otherwise specified,  $V^+ = 5V$ ,  $T_J = 25^\circ C$ . For Full Power Mode the  $I_{SEL}$  pin is connected to  $V^-$ ; for Mid-Power Mode the  $I_{SEL}$  pin is connected to  $V^-$  through a 100 k $\Omega$  resistor; for Low Power Mode the  $I_{SEL}$  pin is connected to  $V^-$  through a 1 M $\Omega$  resistor.

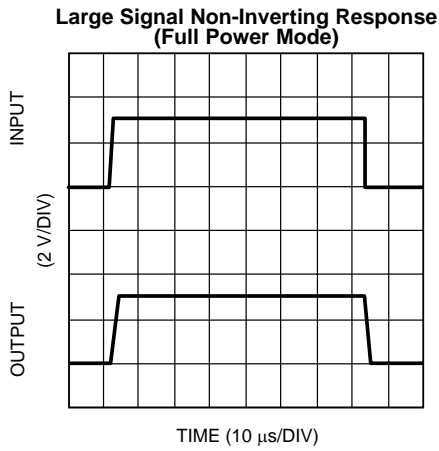

Figure 21.

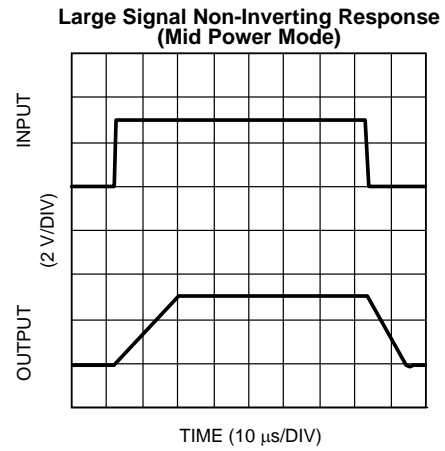

Figure 22.

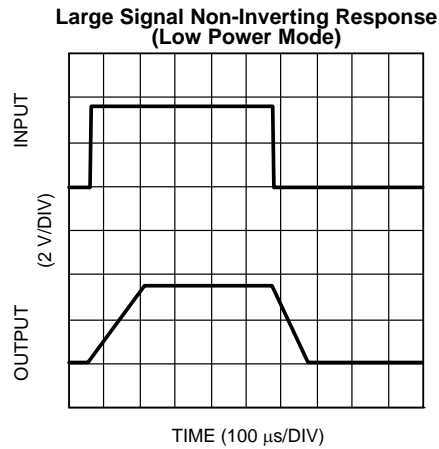

Figure 23.

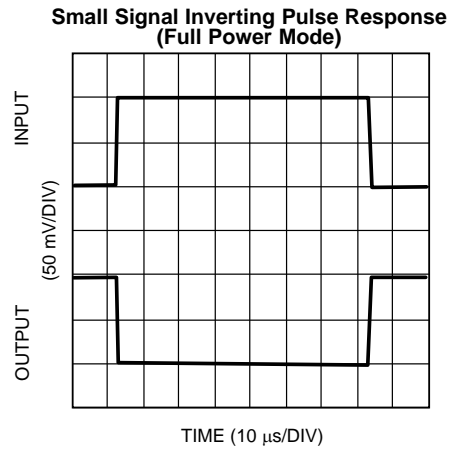

Figure 24.

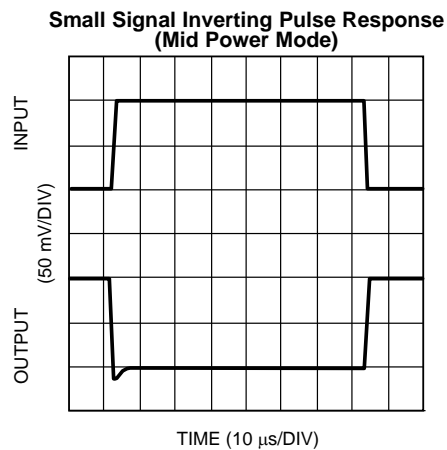

Figure 25.

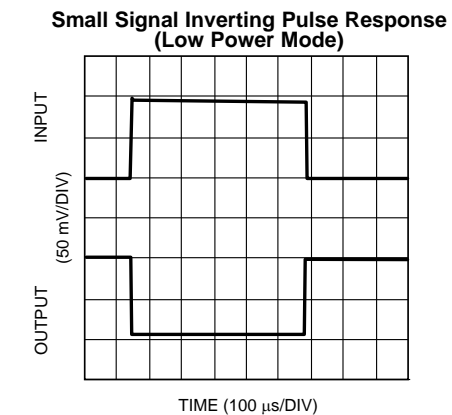
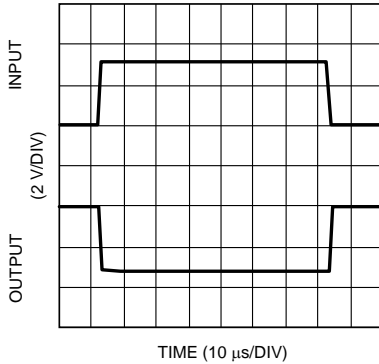

Figure 26.

**Typical Performance Characteristics (continued)**

Unless otherwise specified,  $V^+ = 5V$ ,  $T_J = 25^\circ C$ . For Full Power Mode the  $I_{SEL}$  pin is connected to  $V^-$ ; for Mid-Power Mode the  $I_{SEL}$  pin is connected to  $V^-$  through a 100 k $\Omega$  resistor; for Low Power Mode the  $I_{SEL}$  pin is connected to  $V^-$  through a 1 M $\Omega$  resistor.

**Large Signal Inverting Response (Full Power Mode)**



**Figure 27.**

**Large Signal Inverting Response (Mid Power Mode)**

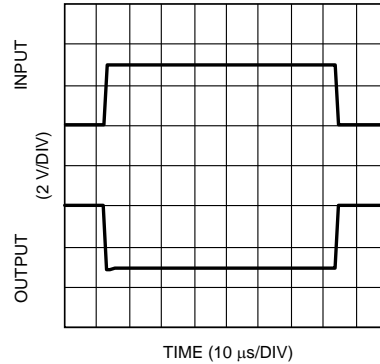

**Figure 28.**

**Large Signal Inverting Response (Low Power Mode)**

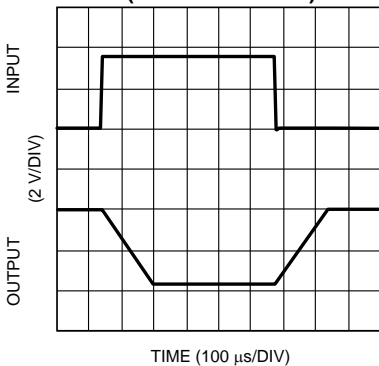

**Figure 29.**

**$I_{SINK}$  vs. Supply Current**

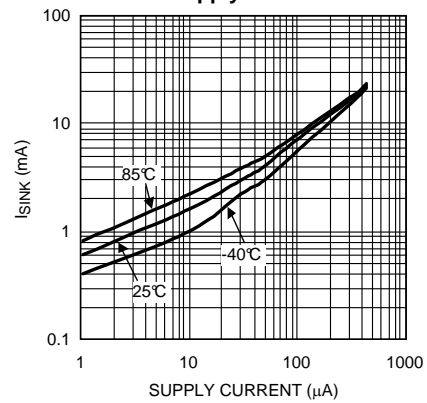

**Figure 30.**

**$I_{SOURCE}$  vs. Supply Current**

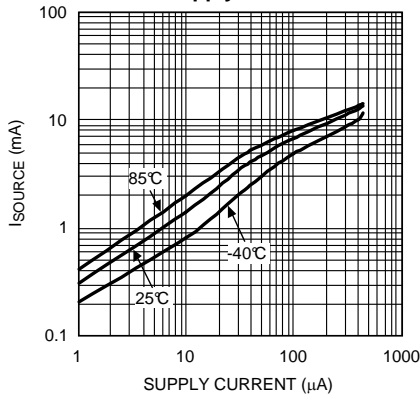

**Figure 31.**

**Gain Bandwidth Product vs.  $I_{SEL}$**

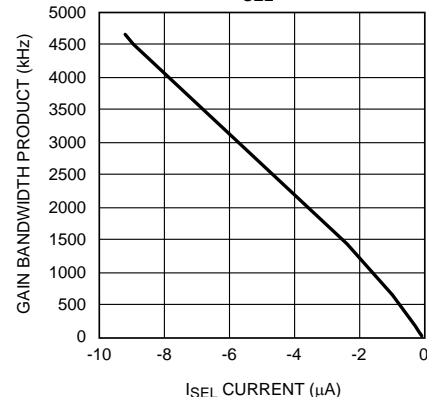

**Figure 32.**

**Typical Performance Characteristics (continued)**

Unless otherwise specified,  $V^+ = 5V$ ,  $T_J = 25^\circ C$ . For Full Power Mode the  $I_{SEL}$  pin is connected to  $V^-$ ; for Mid-Power Mode the  $I_{SEL}$  pin is connected to  $V^-$  through a 100 k $\Omega$  resistor; for Low Power Mode the  $I_{SEL}$  pin is connected to  $V^-$  through a 1 M $\Omega$  resistor.

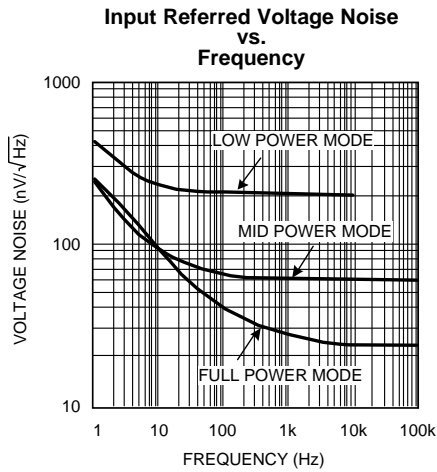

**Figure 33.**

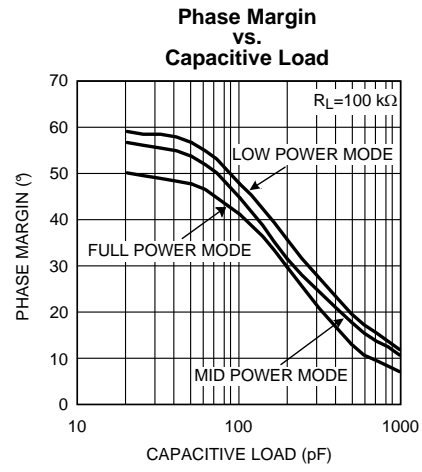

**Figure 34.**

## APPLICATION INFORMATION

The LPV531 is an extremely versatile operational amplifier because performance and power consumption can be adjusted during operation. This provides a method to dynamically optimize the supply current, the bandwidth and the output short circuit current in the application. The power level can be set by the current drawn from the  $I_{SEL}$  pin according to the application performance requirements.

### CIRCUIT TOPOLOGY

As shown in Figure 35, the LPV531 contains two internal bias reference generators that deliver a reference current ( $I_{REF}$ ) to the amplifier core. The programmable bias generator generates a 110 mV reference voltage ( $V_{INT}$ ). This reference voltage is converted into a programmable reference current ( $I_{PROG}$ ) through the internal resistor ( $R_{INT}$ ) and the external resistor ( $R_{EXT}$ ) connected to the  $I_{SEL}$  pin. Internally,  $I_{PROG}$  is added to the output current from the low power bias generator ( $I_{STDB}$ ). When the  $I_{SEL}$  pin is left floating,  $I_{PROG}$  equals zero and the  $I_{REF}$  equals  $I_{STDB}$ . The value of  $I_{STDB}$  is such that in this mode the power supply current is below 1  $\mu$ A. In this 1  $\mu$ A power mode, the LPV531 is functional but performance over the full temperature range is not ensured. The 1  $\mu$ A power mode operation is only recommended for applications with a temperature range between 0 and 70°C.

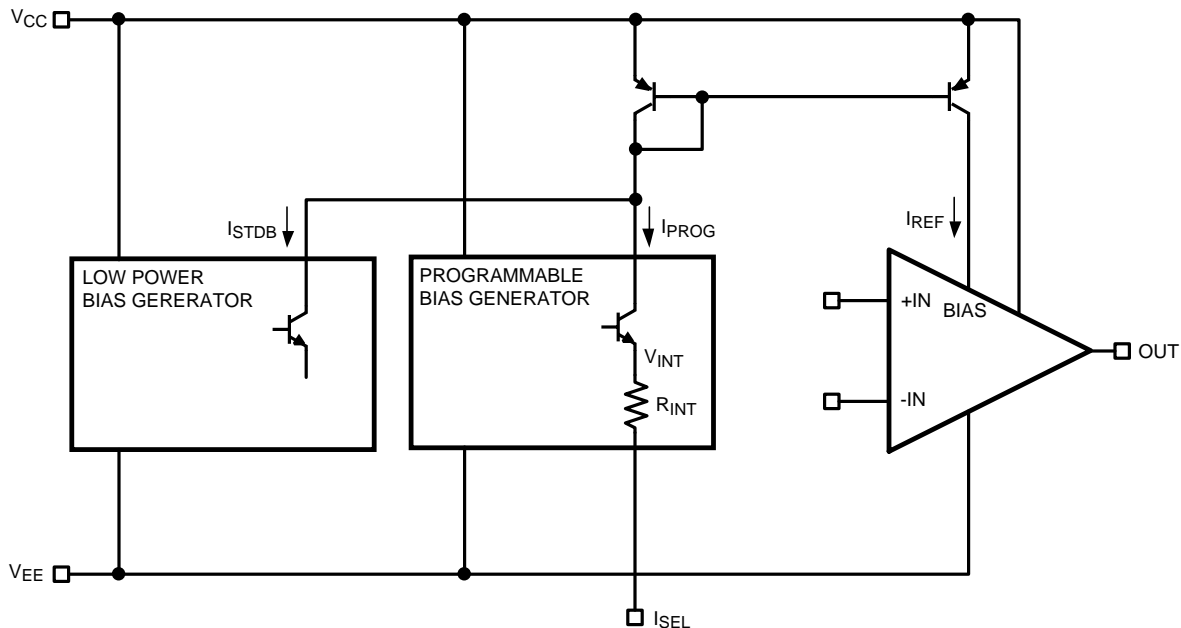

Figure 35. Simplified Schematic

### POWER MODE CONTROL

To illustrate typical configurations three possible solutions to control the power mode(s) of the LPV531 will be described.

#### Single Power Mode

If the application requires one single power mode for the LPV531, then the easiest way to achieve this is to connect a resistor ( $R_{EXT}$ ) from the  $I_{SEL}$  pin to  $V^-$ . Together with the internal circuitry,  $R_{EXT}$  will determine the current drawn from the  $I_{SEL}$  pin. Internally the  $I_{SEL}$  pin is connected to an 11 k $\Omega$  internal series resistor ( $R_{INT}$ ) which is biased at  $V_{INT} = 110$  mV. This set up is illustrated in Figure 36.

For a desired supply current, bandwidth, short circuit current, or load resistance, the required value of  $R_{EXT}$  can be calculated using the equations in the section "DETERMINING THE  $I_{SEL}$  LEVELS".

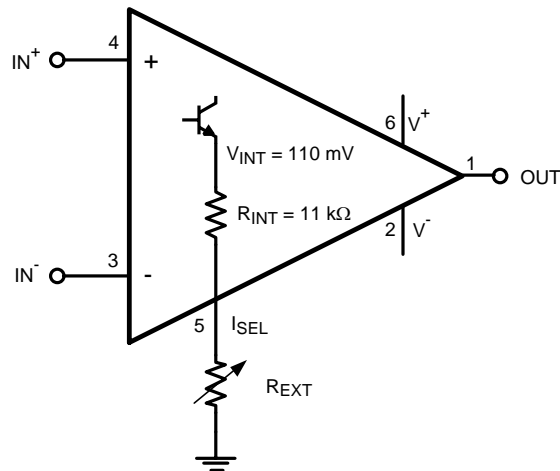

Figure 36. Single Power Mode

**Switched Discrete Power Modes**

In this typical application, the LPV531 can operate at two (or more) power modes in order to fulfill the demands of the design. One of the modes is used to save power. It is a low power mode which is set by using a large resistor. The others are the higher power modes which are set by one or more smaller resistors. The larger resistor that sets the low power mode can be permanently connected while the smaller resistor(s) can be switched in parallel to set the high power mode(s). This configuration allows the designer to get the required performance from the LPV531 when needed.

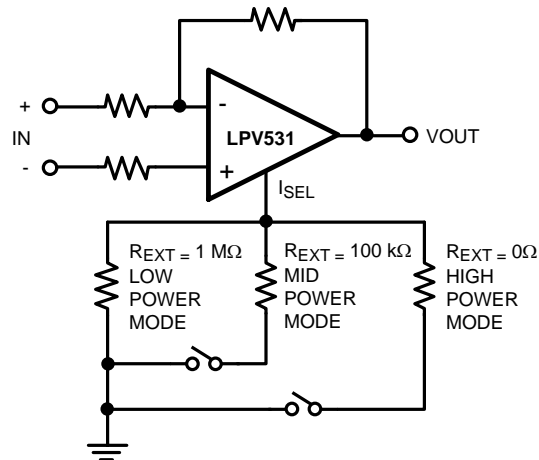

Figure 37. Power Modes Set by Resistors and Switches

The switches shown in Figure 37 can be easily implemented with an open drain I/O port of an ASIC or any other simple pull down switch.

**DAC Controlled Power Modes**

For voltage controlled filter applications, where control of the gain bandwidth is essential, a DAC and a resistive voltage divider can be used. In this application the current drawn from the I\_SEL pin is controlled by the DAC. The DAC's total output range is divided to match the V<sup>-</sup> to V<sub>INT</sub> voltage which has the range of 0-110 mV.

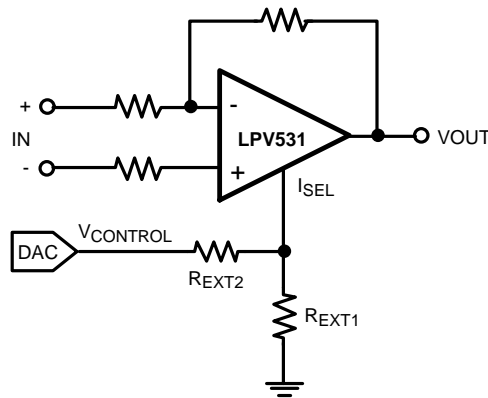

Figure 38. DAC Controlled Power Mode Configurations

The output of the resistive voltage divider should have an impedance that is small compared to the value of  $R_{INT}$  to allow a linear control of the power level. Therefore,  $R_{EXT2}$  needs to have a value in the order of  $R_{INT}/10$  and  $R_{EXT1} = 125 \text{ mV} \cdot R_{EXT2} / V_{CONTROL,MAX}$ . For  $1 \mu\text{A}$  power mode operation, these resistor values will divide the maximum voltage of  $V_{CONTROL}$  to  $125 \text{ mV}$ .

### DETERMINING THE $R_{EXT}$ VALUES AND $I_{SEL}$ LEVELS

To determine the value of  $R_{EXT}$  that is needed for a certain supply current or bandwidth, the following equations can be used:

$$PSI = 1 \mu\text{A} + 40 \times \frac{110 \text{ mV}}{R_{EXT} + 11\text{k}} \quad (1)$$

or

$$R_{EXT} = 40 \times \frac{110 \text{ mV}}{PSI - 1 \mu\text{A}} - 11 \text{ k}\Omega \quad (2)$$

$$GBW = 11 \text{ kHz} + \frac{50[\text{GHz} \cdot \Omega]}{R_{EXT} + 11 \text{ k}\Omega} \quad \text{or} \quad R_{EXT} = \frac{50[\text{GHz} \cdot \Omega]}{GBW - 11 \text{ kHz}} - 11 \text{ k}\Omega \quad (3)$$

For the power modes characterized in this datasheet, these formulas lead to the values in [Table 1](#). These values deviate slightly from the typical values presented in the [Electrical Characteristics](#) tables. The values in [Table 1](#) are calculated using approximated linear equations while the values in the [Electrical Characteristics](#) tables are the result of characterization measurement procedures.

Table 1. Values for Characterized Power Modes

$R_{EXT}$	$I_{SEL}$	Supply Current	Gain Bandwidth Product
1 $\Omega$	9 $\mu\text{A}$	400 $\mu\text{A}$	4.6 MHz
100 k $\Omega$	0.9 $\mu\text{A}$	40 $\mu\text{A}$	460 kHz
1 M $\Omega$	99 nA	5.3 $\mu\text{A}$	60 kHz

To calculate the  $R_{EXT}$  which will allow the LPV531 to deliver a minimum output current at all times and over all temperatures, use the following equations:

$$ISC = \frac{35\text{V}}{R_{EXT} + 11 \text{ k}\Omega} \quad \text{or} \quad R_{EXT} = \frac{35\text{V}}{ISC} - 11 \text{ k}\Omega \quad (4)$$

If the output has to be kept at  $V^+/2$  for a known load resistance, the required  $R_{EXT}$  can be calculated with the following equations:

$$R_{LOAD,MIN} = \frac{0.07}{R_{EXT} + 11 \text{ k}\Omega} \quad \text{or} \quad R_{EXT} = \frac{0.07}{R_{LOAD,MIN}} - 11 \text{ k}\Omega \quad (5)$$

For the characterized power modes these equations lead to the minimum values in [Table 2](#) below.

**Table 2. Minimum Values for Characterized Power Modes**

$R_{EXT}$	$I_{SEL}$	$I_{sc}$	$R_{LOAD}$
1 $\Omega$	9 $\mu\text{A}$	3 mA	770 $\Omega$
100 k $\Omega$	0.9 $\mu\text{A}$	300 $\mu\text{A}$	7.8 k $\Omega$
1 M $\Omega$	99 nA	55 $\mu\text{A}$	70.8 k $\Omega$

The smallest load resistor that the LPV531 can drive when in low power mode is 70.8 k $\Omega$ , as shown in [Table 2](#). When driving smaller loads, such as the 10 k $\Omega$  load resistor used in the [Electrical Characteristics](#) tables specification, the output swing in the low power mode is limited. If the application requires a 10 k $\Omega$  load then it is not recommended to use the LPV531 in low power mode.

### $I_{SEL}$ SENSITIVITY

The  $I_{SEL}$  pin is a current reference that directly affects the entire internal bias condition. Therefore, the  $I_{SEL}$  pin is very sensitive to parasitic signal coupling. In order to protect the  $I_{SEL}$  pin from unwanted distortion, it is important to route the PCB layout such that there is as little coupling between the  $I_{SEL}$  pin and the output or other signal traces as possible.

### Typical Application

#### AC COUPLED CIRCUITS

The programmable power mode makes the LPV531 ideal for AC coupled circuits where the circuit needs to be kept active to maintain a quiescent charge on the coupling capacitors with minimal power consumption. [Figure 39](#) shows the schematic of an inverting AC coupled amplifier using the LPV531 with the  $I_{SEL}$  pin controlled by I/O ports of a microcontroller. The advantage of the low power active mode for AC coupled amplifiers is the elimination of the time needed to re-establish a quiescent operating point when the amplifier is switched to full power mode.

When an amplifier without a low power active mode is used in low power applications, there are two ways to minimize power consumption. The first method turns off the amplifier by switching off power to the op amp using a transistor switch. The second method uses an amplifier with a shutdown pin. Both of these methods have the problem of allowing the coupling capacitors,  $C_1$  and  $C_2$  to discharge the quiescent DC voltage stored on them when in the shutdown state. When the amplifier is turned on again, the quiescent DC voltages must reestablish themselves. During this time, the amplifier's output is not usable because the output signal is a mixture of the amplified input signal and the charging voltage on the coupling capacitors. The settling time can range from a several milliseconds to several seconds depending on the resistor and capacitor values.

When the LPV531 is placed into the low power mode, the power consumption is minimal but the amplifier is active to maintain the quiescent DC voltage on the coupling capacitors. The transition back to the operational high power mode is fast, within a few hundred nanoseconds. The active low power mode of the LPV531 separates two critical aspects of a low power AC amplifier design. The values of the gain resistors, bias resistors, and coupling capacitors can be chosen independently of the turn-on and stabilization time.

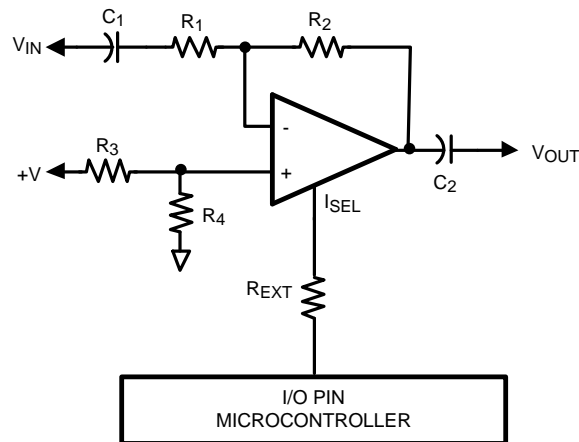

Figure 39. Inverting AC Coupled Application

### PROGRAMMABLE POWER LEVELS AND THE EFFECTS OF STABILITY COMPENSATION METHODS USING EXTERNAL COMPONENTS

In some op amp application circuits, external capacitors are used to improve the stability of the feedback loop around the amplifier. When using the programmable power level feature of the LPV531 such stability improvement methods may not work. This is related to the internal frequency compensation method applied inside the LPV531.

Figure 40 shows the bode plot of the frequency response of the LPV531. The gain-bandwidth product is determined by the transconductance of the input stage ( $g_{m,in}$ ) and the internal Miller compensation capacitor ( $C_m$ ). The non-dominant pole is formed by the transconductance of the output stage ( $g_{m,out}$ ) and the load capacitance connected to the output of the LPV531 ( $C_l$ ). The frequency response crosses the frequency axis with a single-pole slope (20 dB/decade). This ensures the stability of feedback loops formed around the LPV531.

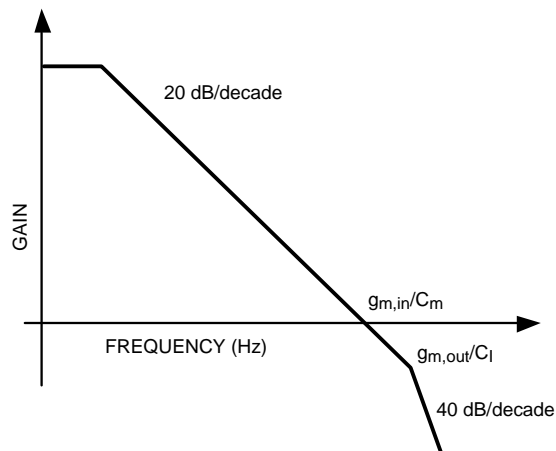

Figure 40. Bode Plot of the Frequency Response

When the load capacitance is increased, the pole at the output will shift to lower frequencies. Eventually, the output pole will shift below the unity gain frequency. This will cause the frequency characteristic to move through the 0 dB axis with a slope of 40 dB/decade and a feedback loop formed around the LPV531 may oscillate. The LPV531 is internally compensated in such a manner that it will be stable for load capacitances up to 100 pF.

When the power setting of the LPV531 is reduced, both the transconductance of the input stage and the transconductance of the output stage will scale linearly with the power level to lower levels. This means that both the unity gain frequency and the pole to the transconductance of the output stage and the load capacitance will move down. Because both the unity gain frequency and the output pole move down in similar amounts, the stability of the LPV531 is still the same. This is shown in Figure 41 which gives the phase margin as a function of the load capacitance in the low power mode (5  $\mu\text{A}$ ), mid-power mode (40  $\mu\text{A}$ ) and high power mode (400  $\mu\text{A}$ ). Though the power level and unity gain frequency move with about two decades, the phase margin as a function of the capacitive load is hardly affected. This means that when the LPV531 is stable in an application circuit with a given load capacitance in the high power mode, the circuit will remain stable with the same capacitive load connected when the power level is reduced.

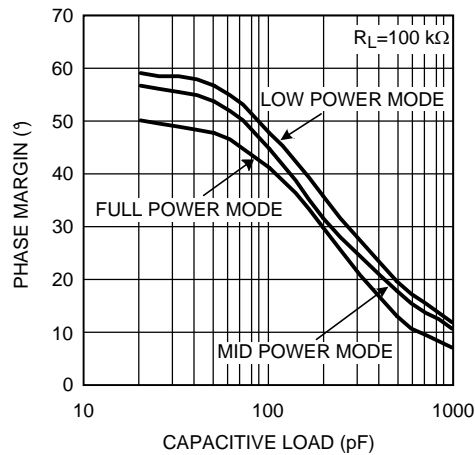

Figure 41. Phase Margin vs. Capacitive Load

Figure 42 shows a method that is sometimes used to allow an op amp to drive larger capacitors than it was originally designed to do. The capacitive load is isolated from the output of the op amp with an isolation resistor ( $R_{ISO}$ ). This moves the output pole, that was originally located at  $g_{m,out}/C_L$ , to a higher frequency. This method requires that the value of  $R_{ISO}$  is in the same order of magnitude as  $1/g_{m,out}$ . For the LPV531, this method will not be effective when used across a broad range of power levels. This is because the high power mode will require a relatively small value for  $R_{ISO}$ , while such a small  $R_{ISO}$  will be ineffective at low power levels. In most applications this should not be a problem as the LPV531 can drive sufficient capacitive loads without the need for an external isolation resistor.

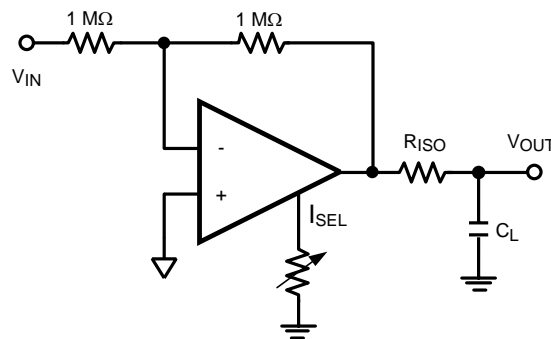
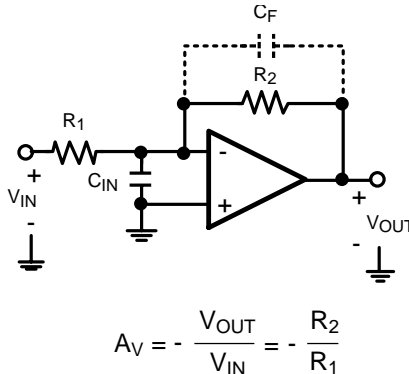

Figure 42. Compensation by Isolation Resistor

## INPUT CAPACITANCE AND FEEDBACK CIRCUIT ELEMENTS

The LPV531 has a very low input bias current (50 fA). To obtain this performance a large CMOS input stage is used, which adds to the input capacitance of the op amp,  $C_{IN}$ . Though this does not affect the DC and low frequency performance, at higher frequencies the input capacitance interacts with the input and the feedback impedances to create a pole, which results in lower phase margin and gain peaking. The gain peaking can be reduced by carefully choosing the appropriate feedback resistor, as well as, by using a feedback capacitance,  $C_F$ . For example, in the inverting amplifier shown in [Figure 43](#), if  $C_{IN}$  and  $C_F$  are ignored and the open loop gain of the op amp is considered infinite then the gain of the circuit is  $-R_2/R_1$ . An op amp, however, usually has a dominant pole, which causes its gain to drop with frequency. Hence, this gain is only valid for DC and low frequency. To understand the effect of the input capacitance coupled with the non-ideal gain of the op amp, the circuit needs to be analyzed in the frequency domain using a Laplace transform.



**Figure 43. Inverting Amplifier**

For simplicity, the op amp is modeled as an ideal integrator with a unity gain frequency of  $A_0$ . Hence, its transfer function (or gain) in the frequency domain is  $A_0/s$ . Solving the circuit equations in the frequency domain, ignoring  $C_F$  for the moment, results in the following equation for the gain:

$$\frac{V_{OUT}}{V_{IN}}(s) = \frac{-R_2/R_1}{1 + \frac{s}{\left(\frac{A_0 R_1}{R_1 + R_2}\right)} + \frac{s^2}{\left(\frac{A_0}{C_{IN} R_2}\right)}} \quad (6)$$

It can be inferred from the denominator of the transfer function that it has two poles, whose expressions can be obtained by solving for the roots of the denominator:

$$P_{1,2} = \frac{-1}{2C_{IN}} \left[ \frac{1}{R_1} + \frac{1}{R_2} \pm \sqrt{\left(\frac{1}{R_1} + \frac{1}{R_2}\right)^2 - \frac{4 A_0 C_{IN}}{R_2}} \right] \quad (7)$$

[Equation 7](#) shows that as the values of  $R_1$  and  $R_2$  are increased, the magnitude of the poles is reduced, and hence the bandwidth of the amplifier is decreased. Furthermore,  $R_1$  and  $R_2$  are related by the gain of the amplifier.

$A_V = -R_2/R_1$ , or alternatively

$R_2 = -A_V R_1$

It is the presence of pairs of poles in [Equation 7](#) that causes gain peaking. In order to eliminate this effect, the poles should be placed in Butterworth position, since poles in Butterworth position do not cause gain peaking. To achieve a Butterworth pair, the quantity under the square root in [Equation 7](#) should be set to equal  $-1$ . Using this fact and the relation between  $R_1$  and  $R_2$ , the optimum value for  $R_1$  can be found. This is shown in [Equation 8](#). If  $R_1$  is chosen to be larger than this optimum value, gain peaking will occur.

$$R_1 < \frac{(1 - A_V)^2}{2A_0A_VC_{IN}} \quad (8)$$

In [Figure 43](#),  $C_F$  is added to compensate for input capacitance and to increase stability. In addition,  $C_F$  reduce or eliminates the gain peaking that can be caused by having a larger feedback resistor.

---

**REVISION HISTORY**

<b>Changes from Revision A (March 2013) to Revision B</b>	<b>Page</b>
<hr/> <ul style="list-style-type: none"><li>• Changed layout of National Data Sheet to TI format .....</li></ul>	<hr/> <a href="#">20</a>

**PACKAGING INFORMATION**

Orderable Device	Status (1)	Package Type	Package Drawing	Pins	Package Qty	Eco Plan (2)	Lead/Ball Finish (6)	MSL Peak Temp (3)	Op Temp (°C)	Device Marking (4/5)	Samples
LPV531MK/NOPB	ACTIVE	SOT-23-THIN	DDC	6	1000	Green (RoHS & no Sb/Br)	CU SN	Level-1-260C-UNLIM	-40 to 85	AV2A	<a href="#">Samples</a>
LPV531MKX/NOPB	ACTIVE	SOT-23-THIN	DDC	6	3000	Green (RoHS & no Sb/Br)	CU SN	Level-1-260C-UNLIM	-40 to 85	AV2A	<a href="#">Samples</a>

(1) The marketing status values are defined as follows:

**ACTIVE:** Product device recommended for new designs.

**LIFEBUY:** TI has announced that the device will be discontinued, and a lifetime-buy period is in effect.

**NRND:** Not recommended for new designs. Device is in production to support existing customers, but TI does not recommend using this part in a new design.

**PREVIEW:** Device has been announced but is not in production. Samples may or may not be available.

**OBsolete:** TI has discontinued the production of the device.

(2) Eco Plan - The planned eco-friendly classification: Pb-Free (RoHS), Pb-Free (RoHS Exempt), or Green (RoHS & no Sb/Br) - please check <http://www.ti.com/productcontent> for the latest availability information and additional product content details.

**TBD:** The Pb-Free/Green conversion plan has not been defined.

**Pb-Free (RoHS):** TI's terms "Lead-Free" or "Pb-Free" mean semiconductor products that are compatible with the current RoHS requirements for all 6 substances, including the requirement that lead not exceed 0.1% by weight in homogeneous materials. Where designed to be soldered at high temperatures, TI Pb-Free products are suitable for use in specified lead-free processes.

**Pb-Free (RoHS Exempt):** This component has a RoHS exemption for either 1) lead-based flip-chip solder bumps used between the die and package, or 2) lead-based die adhesive used between the die and leadframe. The component is otherwise considered Pb-Free (RoHS compatible) as defined above.

**Green (RoHS & no Sb/Br):** TI defines "Green" to mean Pb-Free (RoHS compatible), and free of Bromine (Br) and Antimony (Sb) based flame retardants (Br or Sb do not exceed 0.1% by weight in homogeneous material)

(3) MSL, Peak Temp. - The Moisture Sensitivity Level rating according to the JEDEC industry standard classifications, and peak solder temperature.

(4) There may be additional marking, which relates to the logo, the lot trace code information, or the environmental category on the device.

(5) Multiple Device Markings will be inside parentheses. Only one Device Marking contained in parentheses and separated by a "~" will appear on a device. If a line is indented then it is a continuation of the previous line and the two combined represent the entire Device Marking for that device.

(6) Lead/Ball Finish - Orderable Devices may have multiple material finish options. Finish options are separated by a vertical ruled line. Lead/Ball Finish values may wrap to two lines if the finish value exceeds the maximum column width.

**Important Information and Disclaimer:** The information provided on this page represents TI's knowledge and belief as of the date that it is provided. TI bases its knowledge and belief on information provided by third parties, and makes no representation or warranty as to the accuracy of such information. Efforts are underway to better integrate information from third parties. TI has taken and continues to take reasonable steps to provide representative and accurate information but may not have conducted destructive testing or chemical analysis on incoming materials and chemicals. TI and TI suppliers consider certain information to be proprietary, and thus CAS numbers and other limited information may not be available for release.

In no event shall TI's liability arising out of such information exceed the total purchase price of the TI part(s) at issue in this document sold by TI to Customer on an annual basis.

## TAPE AND REEL INFORMATION



### QUADRANT ASSIGNMENTS FOR PIN 1 ORIENTATION IN TAPE



\*All dimensions are nominal

Device	Package Type	Package Drawing	Pins	SPQ	Reel Diameter (mm)	Reel Width W1 (mm)	A0 (mm)	B0 (mm)	K0 (mm)	P1 (mm)	W (mm)	Pin1 Quadrant
LPV531MK/NOPB	SOT-23-THIN	DDC	6	1000	178.0	8.4	3.2	3.2	1.4	4.0	8.0	Q3
LPV531MKX/NOPB	SOT-23-THIN	DDC	6	3000	178.0	8.4	3.2	3.2	1.4	4.0	8.0	Q3

**TAPE AND REEL BOX DIMENSIONS**



\*All dimensions are nominal

Device	Package Type	Package Drawing	Pins	SPQ	Length (mm)	Width (mm)	Height (mm)
LPV531MK/NOPB	SOT-23-THIN	DDC	6	1000	210.0	185.0	35.0
LPV531MKX/NOPB	SOT-23-THIN	DDC	6	3000	210.0	185.0	35.0

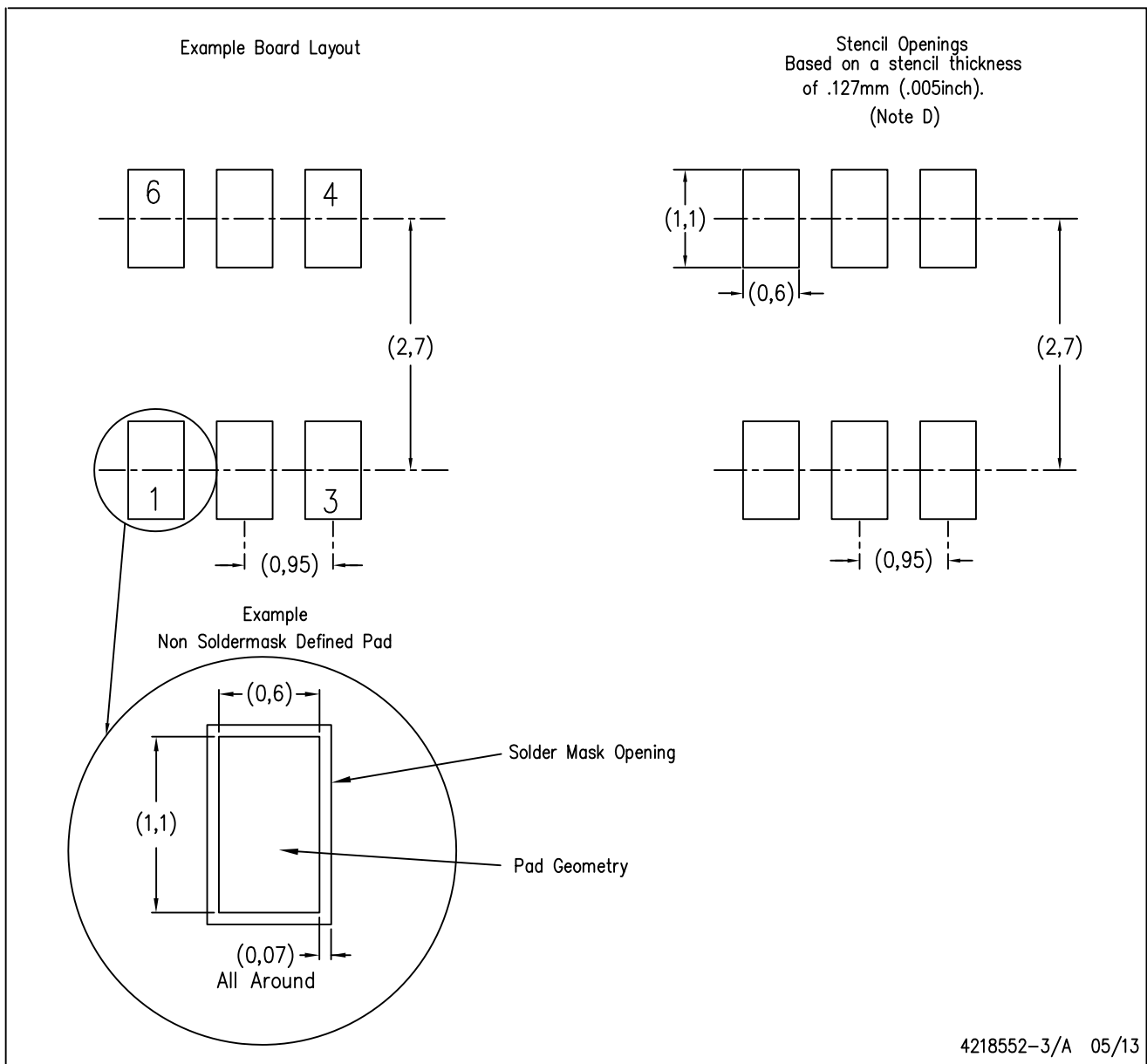

DDC (R-PDSO-G6)

PLASTIC SMALL OUTLINE



- NOTES:
- A. All linear dimensions are in millimeters.
  - B. This drawing is subject to change without notice.
  - C. Publication IPC-7351 is recommended for alternate designs.
  - D. Laser cutting apertures with trapezoidal walls and also rounding corners will offer better paste release. Customers should contact their board assembly site for stencil design recommendations. Example stencil design based on a 50% volumetric metal load solder paste. Refer to IPC-7525 for other stencil recommendations.

## IMPORTANT NOTICE

Texas Instruments Incorporated (TI) reserves the right to make corrections, enhancements, improvements and other changes to its semiconductor products and services per JESD46, latest issue, and to discontinue any product or service per JESD48, latest issue. Buyers should obtain the latest relevant information before placing orders and should verify that such information is current and complete.

TI's published terms of sale for semiconductor products (<http://www.ti.com/sc/docs/stdterms.htm>) apply to the sale of packaged integrated circuit products that TI has qualified and released to market. Additional terms may apply to the use or sale of other types of TI products and services.

Reproduction of significant portions of TI information in TI data sheets is permissible only if reproduction is without alteration and is accompanied by all associated warranties, conditions, limitations, and notices. TI is not responsible or liable for such reproduced documentation. Information of third parties may be subject to additional restrictions. Resale of TI products or services with statements different from or beyond the parameters stated by TI for that product or service voids all express and any implied warranties for the associated TI product or service and is an unfair and deceptive business practice. TI is not responsible or liable for any such statements.

Buyers and others who are developing systems that incorporate TI products (collectively, "Designers") understand and agree that Designers remain responsible for using their independent analysis, evaluation and judgment in designing their applications and that Designers have full and exclusive responsibility to assure the safety of Designers' applications and compliance of their applications (and of all TI products used in or for Designers' applications) with all applicable regulations, laws and other applicable requirements. Designer represents that, with respect to their applications, Designer has all the necessary expertise to create and implement safeguards that (1) anticipate dangerous consequences of failures, (2) monitor failures and their consequences, and (3) lessen the likelihood of failures that might cause harm and take appropriate actions. Designer agrees that prior to using or distributing any applications that include TI products, Designer will thoroughly test such applications and the functionality of such TI products as used in such applications.

TI's provision of technical, application or other design advice, quality characterization, reliability data or other services or information, including, but not limited to, reference designs and materials relating to evaluation modules, (collectively, "TI Resources") are intended to assist designers who are developing applications that incorporate TI products; by downloading, accessing or using TI Resources in any way, Designer (individually or, if Designer is acting on behalf of a company, Designer's company) agrees to use any particular TI Resource solely for this purpose and subject to the terms of this Notice.

TI's provision of TI Resources does not expand or otherwise alter TI's applicable published warranties or warranty disclaimers for TI products, and no additional obligations or liabilities arise from TI providing such TI Resources. TI reserves the right to make corrections, enhancements, improvements and other changes to its TI Resources. TI has not conducted any testing other than that specifically described in the published documentation for a particular TI Resource.

Designer is authorized to use, copy and modify any individual TI Resource only in connection with the development of applications that include the TI product(s) identified in such TI Resource. NO OTHER LICENSE, EXPRESS OR IMPLIED, BY ESTOPPEL OR OTHERWISE TO ANY OTHER TI INTELLECTUAL PROPERTY RIGHT, AND NO LICENSE TO ANY TECHNOLOGY OR INTELLECTUAL PROPERTY RIGHT OF TI OR ANY THIRD PARTY IS GRANTED HEREIN, including but not limited to any patent right, copyright, mask work right, or other intellectual property right relating to any combination, machine, or process in which TI products or services are used. Information regarding or referencing third-party products or services does not constitute a license to use such products or services, or a warranty or endorsement thereof. Use of TI Resources may require a license from a third party under the patents or other intellectual property of the third party, or a license from TI under the patents or other intellectual property of TI.

TI RESOURCES ARE PROVIDED "AS IS" AND WITH ALL FAULTS. TI DISCLAIMS ALL OTHER WARRANTIES OR REPRESENTATIONS, EXPRESS OR IMPLIED, REGARDING RESOURCES OR USE THEREOF, INCLUDING BUT NOT LIMITED TO ACCURACY OR COMPLETENESS, TITLE, ANY EPIDEMIC FAILURE WARRANTY AND ANY IMPLIED WARRANTIES OF MERCHANTABILITY, FITNESS FOR A PARTICULAR PURPOSE, AND NON-INFRINGEMENT OF ANY THIRD PARTY INTELLECTUAL PROPERTY RIGHTS. TI SHALL NOT BE LIABLE FOR AND SHALL NOT DEFEND OR INDEMNIFY DESIGNER AGAINST ANY CLAIM, INCLUDING BUT NOT LIMITED TO ANY INFRINGEMENT CLAIM THAT RELATES TO OR IS BASED ON ANY COMBINATION OF PRODUCTS EVEN IF DESCRIBED IN TI RESOURCES OR OTHERWISE. IN NO EVENT SHALL TI BE LIABLE FOR ANY ACTUAL, DIRECT, SPECIAL, COLLATERAL, INDIRECT, PUNITIVE, INCIDENTAL, CONSEQUENTIAL OR EXEMPLARY DAMAGES IN CONNECTION WITH OR ARISING OUT OF TI RESOURCES OR USE THEREOF, AND REGARDLESS OF WHETHER TI HAS BEEN ADVISED OF THE POSSIBILITY OF SUCH DAMAGES.

Unless TI has explicitly designated an individual product as meeting the requirements of a particular industry standard (e.g., ISO/TS 16949 and ISO 26262), TI is not responsible for any failure to meet such industry standard requirements.

Where TI specifically promotes products as facilitating functional safety or as compliant with industry functional safety standards, such products are intended to help enable customers to design and create their own applications that meet applicable functional safety standards and requirements. Using products in an application does not by itself establish any safety features in the application. Designers must ensure compliance with safety-related requirements and standards applicable to their applications. Designer may not use any TI products in life-critical medical equipment unless authorized officers of the parties have executed a special contract specifically governing such use. Life-critical medical equipment is medical equipment where failure of such equipment would cause serious bodily injury or death (e.g., life support, pacemakers, defibrillators, heart pumps, neurostimulators, and implantables). Such equipment includes, without limitation, all medical devices identified by the U.S. Food and Drug Administration as Class III devices and equivalent classifications outside the U.S.

TI may expressly designate certain products as completing a particular qualification (e.g., Q100, Military Grade, or Enhanced Product). Designers agree that it has the necessary expertise to select the product with the appropriate qualification designation for their applications and that proper product selection is at Designers' own risk. Designers are solely responsible for compliance with all legal and regulatory requirements in connection with such selection.

Designer will fully indemnify TI and its representatives against any damages, costs, losses, and/or liabilities arising out of Designer's non-compliance with the terms and provisions of this Notice.

## Looking for pricing, stock, or lifecycle information?

Click below to explore more details on WIN SOURCE:

 [View LPV531MKX/NOPB on WIN SOURCE](#)

 [Texas Instruments](#) Information

## Optimize Your Supply Chain with WIN SOURCE Solutions

-  Global Sourcing Solution
-  Obsolete Management
-  Cost Control Management
-  Shortage Management
-  Alternative Solution
-  Excess Inventory Management