



**THE DATASHEET OF
LT1071IT**



5A and 2.5A High Efficiency Switching Regulators

FEATURES

- Wide Input Voltage Range: 3V to 60V
- Low Quiescent Current: 6mA
- Internal 5A Switch (2.5A for LT1071)
- Very Few External Parts Required
- Self Protected Against Overloads
- Operates in Nearly All Switching Topologies
- Shutdown Mode Draws Only 50 μ A Supply Current
- Flyback Regulated Mode Has Fully Floating Outputs
- Comes in Standard 5-Pin TO-220 Package
- Can be Externally Synchronized (Consult Factory)

APPLICATIONS

- Logic Supply 5V at 10A
- 5V Logic to \pm 15V Op Amp Supply
- Off-Line Converter Up to 200W
- Battery Upconverter
- Power Inverter (+ to -) or (- to +)
- Fully Floating Multiple Outputs
- For Lower Current Applications, See the LT1072

USER NOTE:

This data sheet is only intended to provide specifications, graphs and a general functional description of the LT1070/LT1071. Application circuits are included to show the capability of the LT1070/LT1071. A complete design manual (AN19) should be obtained to assist in developing new designs. This manual contains a comprehensive discussion of both the LT1070 and the external components used with it, as well as complete formulas for calculating the values of these components. The manual can also be used for the LT1071 by factoring in the lower switch current rating. A second Application Note, AN25, which details off-line applications is available.

DESCRIPTION

The LT[®]1070/LT1071 are monolithic high power switching regulators. They can be operated in all standard switching configurations including buck, boost, flyback, forward, inverting and "Cuk". A high current, high efficiency switch is included on the die along with all oscillator, control and protection circuitry. Integration of all functions allows the LT1070/LT1071 to be built in a standard 5-pin TO-220 power package. This makes it extremely easy to use and provides "bust proof" operation similar to that obtained with 3-pin linear regulators.

The LT1070/LT1071 operate with supply voltages from 3V to 60V, and draw only 6mA quiescent current. They can deliver load power up to 100W with no external power devices. By utilizing current mode switching techniques, they provide excellent AC and DC load and line regulation.

The LT1070/LT1071 have many unique features not found even on the vastly more difficult to use low power control chips presently available. They use adaptive antisat switch drive to allow very wide ranging load currents with no loss in efficiency. An externally activated shutdown mode reduces total supply current to 50 μ A typical for standby operation. Totally isolated and regulated outputs can be generated by using the optional "flyback regulation mode" built into the LT1070/LT1071, without the need for optocouplers or extra transformer windings.

LT, LTC and LT are registered trademarks of Linear Technology Corporation.

TYPICAL APPLICATION

Boost Converter (5V to 12V)

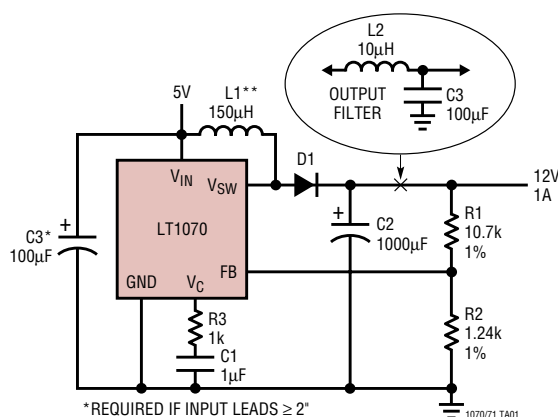

REQUIRED IF INPUT LEADS $\geq 2^$

**PULSE ENGINEERING 92113

Maximum Output Power*

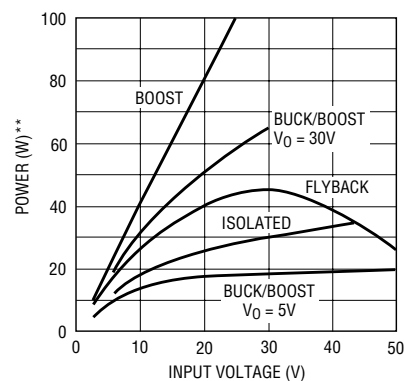

1070/71 TA02

*ROUGH GUIDE ONLY. BUCK MODE $P_{OUT} = 5A \cdot V_{OUT}$. SPECIAL TOPOLOGIES DELIVER MORE POWER

**DIVIDE VERTICAL POWER SCALE BY 2 FOR LT1071

LT1070/LT1071

ABSOLUTE MAXIMUM RATINGS (Note 1)

Supply Voltage	Operating Junction Temperature Range
LT1070/LT1071 (Note 2) 40V	Commercial (Operating) 0°C to 100°C
LT1070HV/LT1071HV (Note 2) 60V	Commercial (Short Circuit) 0°C to 125°C
Switch Output Voltage	Industrial -40°C to 125°C
LT1070/LT1071 65V	Military (OBSOLETE) -55°C to 150°C
LT1070HV/LT1071HV 75V	Storage Temperature Range -65°C to 150°C
Feedback Pin Voltage (Transient, 1ms) ±15V	Lead Temperature (Soldering, 10 sec) 300°C

PACKAGE/ORDER INFORMATION

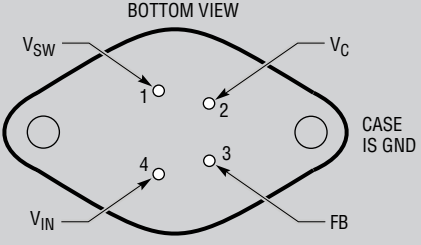
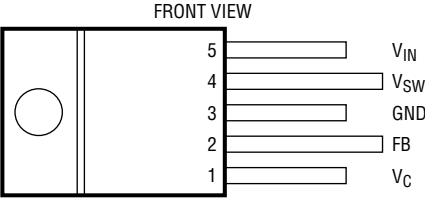
 <p>BOTTOM VIEW</p> <p>K PACKAGE 4-LEAD TO-3 METAL CAN</p> <p>$T_{JMAX} = 100^{\circ}C, \theta_{JA} = 35^{\circ}C/W, Q_{JC} = 2^{\circ}C$ (LT1070C, I) $T_{JMAX} = 150^{\circ}C, \theta_{JA} = 35^{\circ}C/W, Q_{JC} = 2^{\circ}C$ (LT1070M) $T_{JMAX} = 100^{\circ}C, \theta_{JA} = 35^{\circ}C/W, Q_{JC} = 4^{\circ}C$ (LT1071C, I) $T_{JMAX} = 150^{\circ}C, \theta_{JA} = 35^{\circ}C/W, Q_{JC} = 4^{\circ}C$ (LT1071M)</p> <p>OBSOLETE PACKAGE Consider the T5 Package for Alternate Source</p>	<p>ORDER PART NUMBER</p> <p>LT1070CK LT1070HVCK LT1070HVMK LT1070IK LT1070MK LT1071CK LT1071HVCK LT1071HVMK LT1071MK</p>	 <p>FRONT VIEW</p> <p>T PACKAGE 5-LEAD PLASTIC TO-220</p> <p>$T_{JMAX} = 100^{\circ}C, \theta_{JA} = 75^{\circ}C/W, Q_{JC} = 2^{\circ}C$ (LT1070C, I) $T_{JMAX} = 100^{\circ}C, \theta_{JA} = 75^{\circ}C/W, Q_{JC} = 4^{\circ}C$ (LT1071C)</p>	<p>ORDER PART NUMBER</p> <p>LT1070CT LT1070HVCT LT1070HVIT LT1070IT LT1071CT LT1071HVCT LT1071HVIT LT1071IT</p>

Consult LTC Marketing for parts specified with wider operating temperature ranges.

ELECTRICAL CHARACTERISTICS

The ● denotes the specifications which apply over the full operating temperature range, otherwise specifications are at $T_A = 25^{\circ}C$. $V_{IN} = 15V$, $V_C = 0.5V$, $V_{FB} = V_{REF}$, output pin open unless otherwise specified.

SYMBOL	PARAMETER	CONDITIONS	MIN	TYP	MAX	UNITS
V_{REF}	Reference Voltage	Measured at Feedback Pin, $V_C = 0.8V$	● 1.224	1.244	1.264	V
			1.214	1.244	1.274	V
I_B	Feedback Input Current	$V_{FB} = V_{REF}$	●	350	750	nA
			●		1100	nA
g_m	Error Amplifier Transconductance	$\Delta I_C = \pm 25\mu A$	● 3000	4400	6000	μmho
			● 2400		7000	μmho
	Error Amplifier Source or Sink Current	$V_C = 1.5V$	● 150	200	350	μA
			● 120		400	μA
	Error Amplifier Clamp Voltage	Hi Clamp, $V_{FB} = 1V$ Lo Clamp, $V_{FB} = 1.5V$	● 1.80		2.30	V
			0.25	0.38	0.52	V
	Reference Voltage Line Regulation	$3V \leq V_{IN} \leq V_{MAX}$, $V_C = 0.8V$	●		0.03	%/V
A_V	Error Amplifier Voltage Gain	$0.9V \leq V_C \leq 1.4V$	● 500	800		V/V
			●	2.6	3.0	V
I_Q	Supply Current	$3V \leq V_{IN} \leq V_{MAX}$, $V_C = 0.6V$	●	6	9	mA
			●	0.8	0.9	1.08
	Control Pin Threshold	Duty Cycle = 0	● 0.6		1.25	V
			●	0.4	0.45	0.54
	Normal/Flyback Threshold on Feedback Pin		●			V

10701fe

ELECTRICAL CHARACTERISTICS The ● denotes the specifications which apply over the full operating temperature range, otherwise specifications are at T_A = 25°C. V_{IN} = 15V, V_C = 0.5V, V_{FB} = V_{REF}, output pin open unless otherwise specified.

SYMBOL	PARAMETER	CONDITIONS	MIN	TYP	MAX	UNITS
V _{FB}	Flyback Reference Voltage	I _{FB} = 50μA	15	16.3	17.6	V
			● 14		18.0	V
	Change in Flyback Reference Voltage	0.05 ≤ I _{FB} ≤ 1mA	4.5	6.8	8.5	V
	Flyback Reference Voltage Line Regulation	I _{FB} = 50μA, 3V ≤ V _{IN} ≤ V _{MAX} (Note 3)		0.01	0.03	%/V
	Flyback Amplifier Transconductance (g _m)	ΔI _C = ±10μA	150	300	650	μmho
	Flyback Amplifier Source and Sink Current	V _C = 0.6V, I _{FB} = 50μA (Source) V _C = 0.6V, I _{FB} = 50μA (Sink)	● 15	32	70	μA
			● 25	40	70	μA
B _V	Output Switch Breakdown Voltage	3V ≤ V _{IN} ≤ V _{MAX} , I _{SW} = 1.5mA (LT1070/LT1071) (LT1070HV/LT1071HV)	● 65	90		V
			● 75	90		V
V _{SAT}	Output Switch “On” Resistance (Note 4)	LT1070	●	0.15	0.24	Ω
		LT1071	●	0.30	0.50	Ω
	Control Voltage to Switch Current Transconductance	LT1070		8		A/V
		LT1071		4		A/V
I _{LIM}	Switch Current Limit (LT1070)	Duty Cycle ≤ 50%, T _J ≥ 25°C	● 5		10	A
		Duty Cycle ≤ 50%, T _J < 25°C	● 5		11	A
		Duty Cycle = 80% (Note 5)	● 4		10	A
	Switch Current Limit (LT1071)	Duty Cycle ≤ 50%, T _J ≥ 25°C	● 2.5		5.0	A
		Duty Cycle ≤ 50%, T _J < 25°C	● 2.5		5.5	A
		Duty Cycle = 80% (Note 5)	● 2.0		5.0	A
$\frac{\Delta I_{IN}}{\Delta I_{SW}}$	Supply Current Increase During Switch “On” Time			25	35	mA/A
f	Switching Frequency		35	40	45	kHz
			● 33		47	kHz
DC (Max)	Maximum Switch Duty Cycle		90	92	97	%
	Flyback Sense Delay Time			1.5		μs
	Shutdown Mode Supply Current	3V ≤ V _{IN} ≤ V _{MAX} , V _C = 0.05V		100	250	μA
	Shutdown Mode Threshold Voltage	3V ≤ V _{IN} ≤ V _{MAX}	100	150	250	mV
			● 50		300	mV

Note 1: Absolute Maximum Ratings are those values beyond which the life of a device may be impaired.

Note 2: Minimum switch “on” time for the LT1070/LT1071 in current limit is ≈1μs. This limits the maximum input voltage during short-circuit conditions, in the buck and inverting modes only, to ≈35V. Normal (unshorted) conditions are not affected. Mask changes are being implemented which will reduce minimum “on” time to ≤1μs, increasing maximum short-circuit input voltage above 40V. If the present LT1070/LT1071 (contact factory for package date code) is being operated in the buck or inverting mode at high input voltages and short-circuit conditions are expected, a resistor must be placed in series with the inductor, as follows:

The value of the resistor is given by:

$$R = \frac{t \cdot f \cdot V_{IN} - V_F}{I_{LIMIT}} - R_L$$

t = Minimum “on” time of LT1070/LT1071 in current limit, ≈1μs

f = Operating frequency (40kHz)

V_F = Forward voltage of external catch diode at I_{LIMIT}

I_{LIMIT} = Current limit of LT1070 (≈8A), LT1071 (≈4A)

R_L = Internal series resistance of inductor

Note 3: V_{MAX} = 55V for LT1070HV and LT1071HV to avoid switch breakdown.

Note 4: Measured with V_C in hi clamp, V_{FB} = 0.8V. I_{SW} = 4A for LT1070 and 2A for LT1071.

Note 5: For duty cycles (DC) between 50% and 80%, minimum guaranteed switch current is given by I_{LIM} = 3.33 (2 – DC) for the LT1070 and I_{LIM} = 1.67 (2 – DC) for the LT1071.

TYPICAL PERFORMANCE CHARACTERISTICS

Switch Current Limit vs Duty Cycle

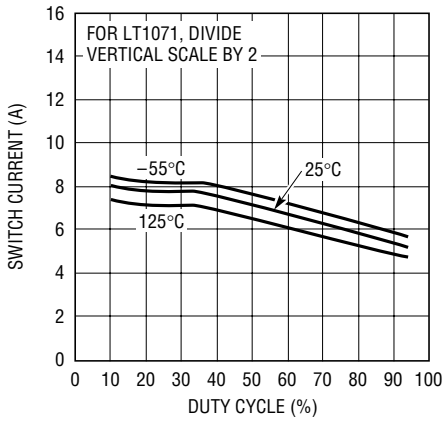

1070/71 G01

Maximum Duty Cycle

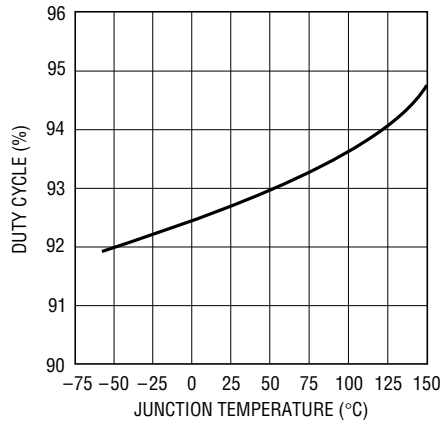

1070/71 G02

Flyback Blanking Time

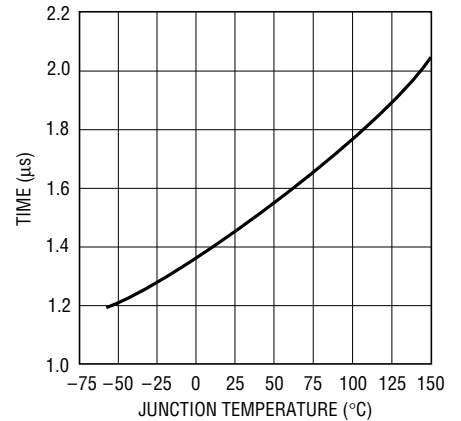

1070/71 G03

Minimum Input Voltage

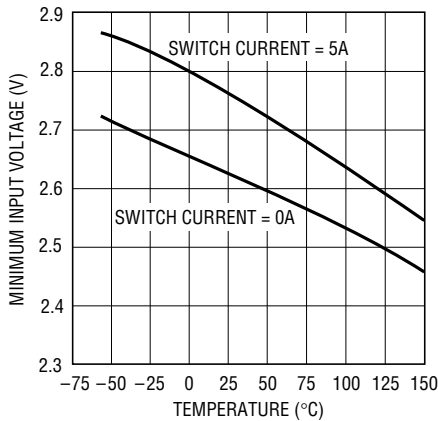

1070/71 G04

Switch Saturation Voltage

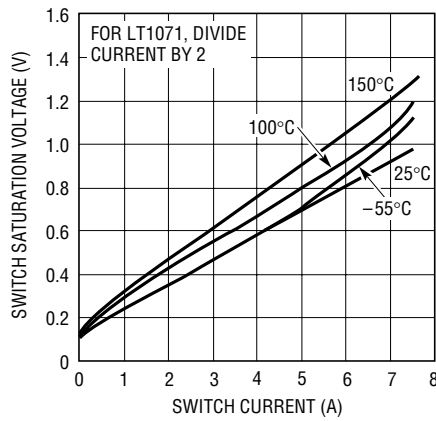

1070/71 G05

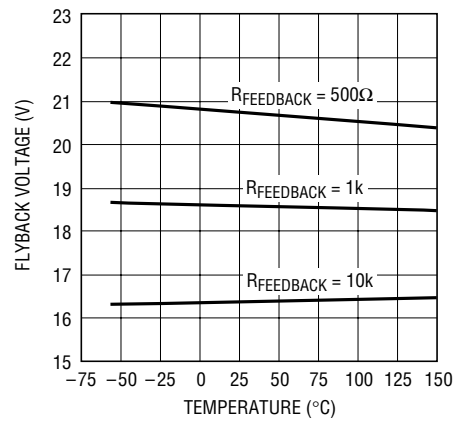

1070/71 G06

Line Regulation

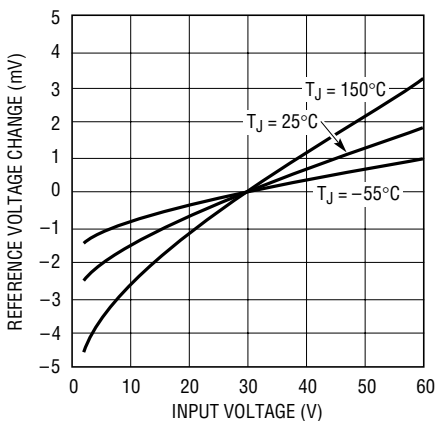

1070/71 G07

Reference Voltage vs Temperature

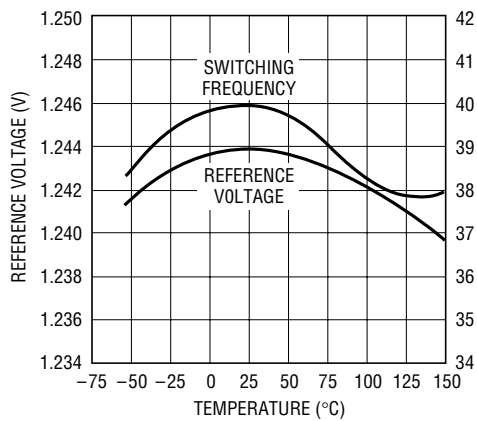

1070/71 G08

Feedback Bias Current vs Temperature

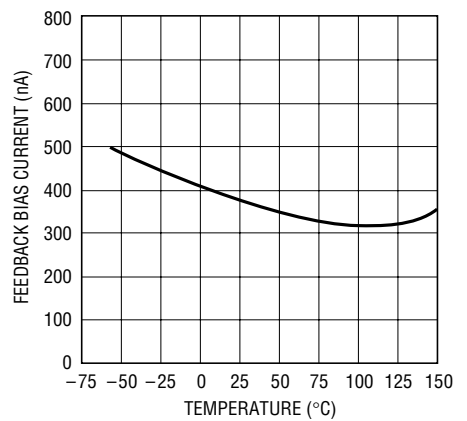

1070/71 G09

TYPICAL PERFORMANCE CHARACTERISTICS

Driver Current* vs Switch Current

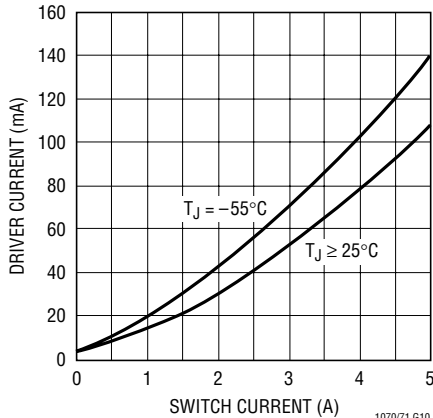

* AVERAGE LT1070 POWER SUPPLY CURRENT IS FOUND BY MULTIPLYING DRIVER CURRENT BY DUTY CYCLE, THEN ADDING QUIESCENT CURRENT

Supply Current vs Input Voltage*

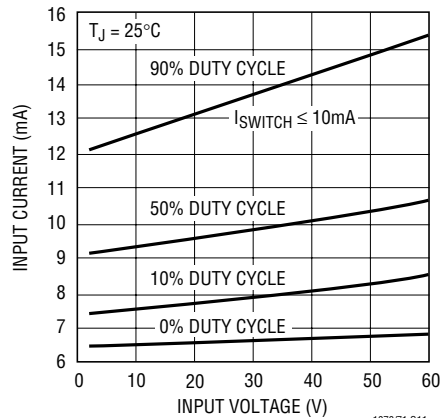

* UNDER VERY LOW OUTPUT CURRENT CONDITIONS, DUTY CYCLE FOR MOST CIRCUITS WILL APPROACH 10% OR LESS

Supply Current vs Supply Voltage (Shutdown Mode)

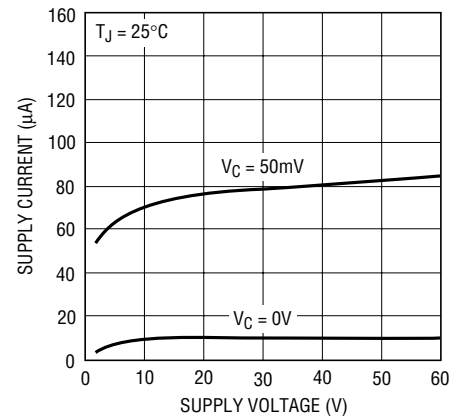

1070/71 G12

Normal/Flyback Mode Threshold on Feedback Pin

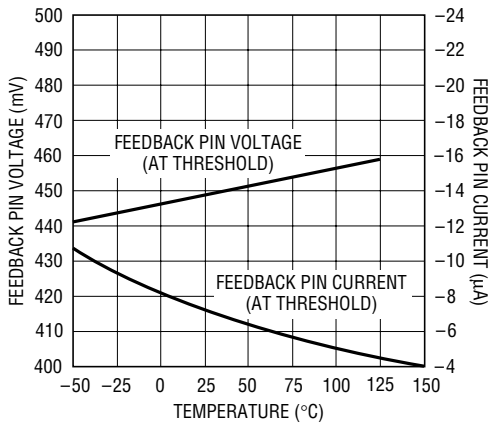

1070/71 G13

Shutdown Mode Supply Current

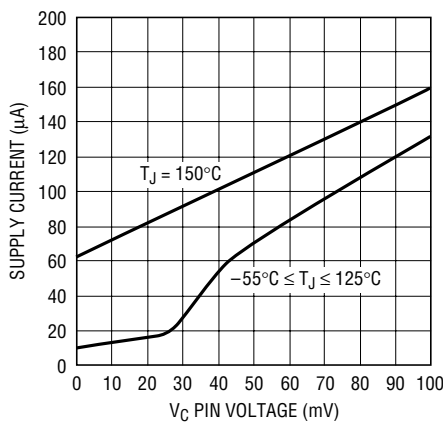

1070/71 G14

Error Amplifier Transconductance

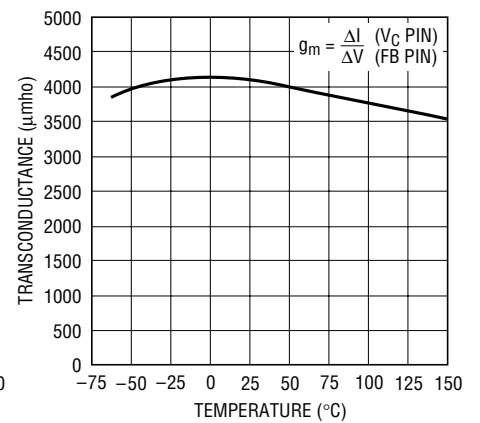

1070/71 G14

Shutdown Thresholds

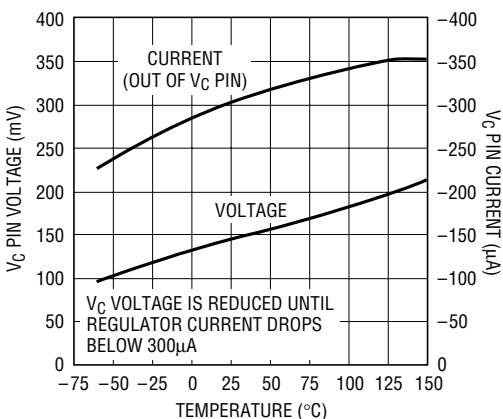

1070/71 G16

Idle Supply Current vs Temperature

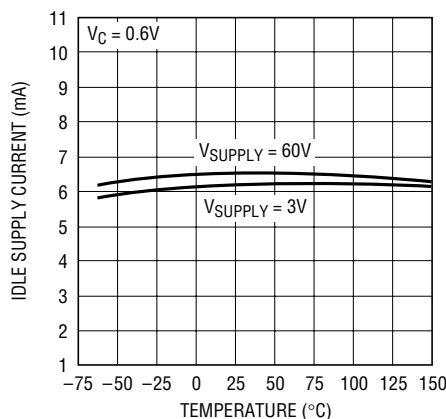

1070/71 G14

Feedback Pin Clamp Voltage

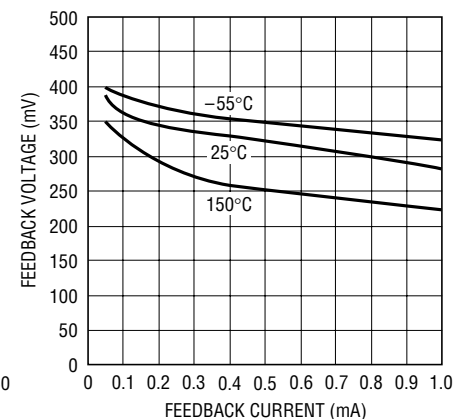

1070/71 G18
10701fe

TYPICAL PERFORMANCE CHARACTERISTICS

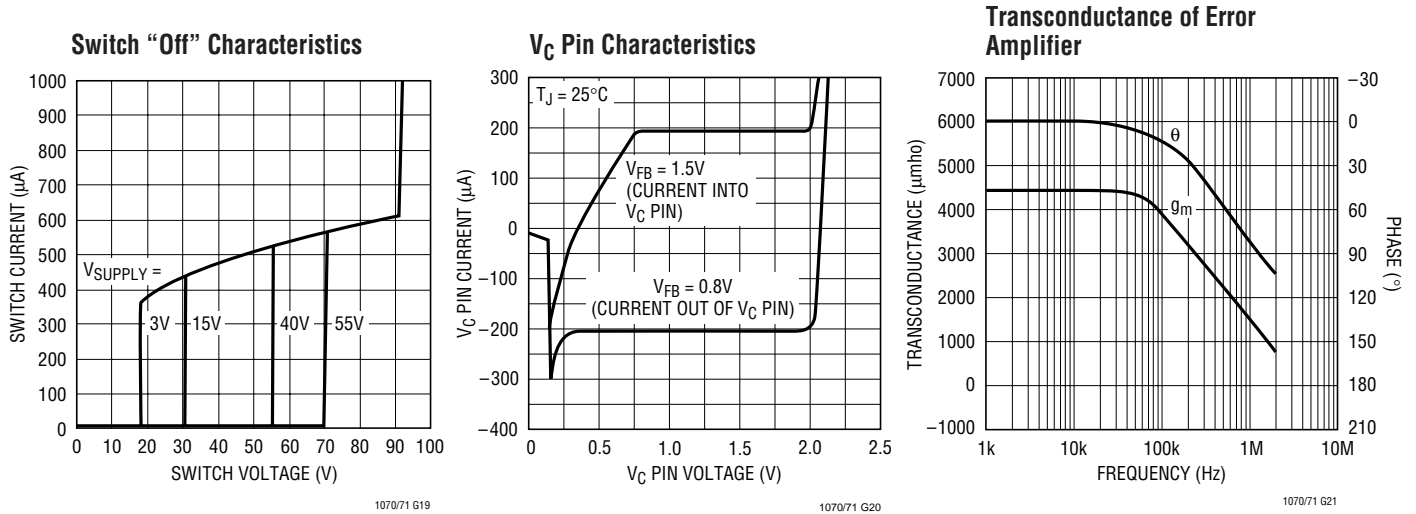

BLOCK DIAGRAM

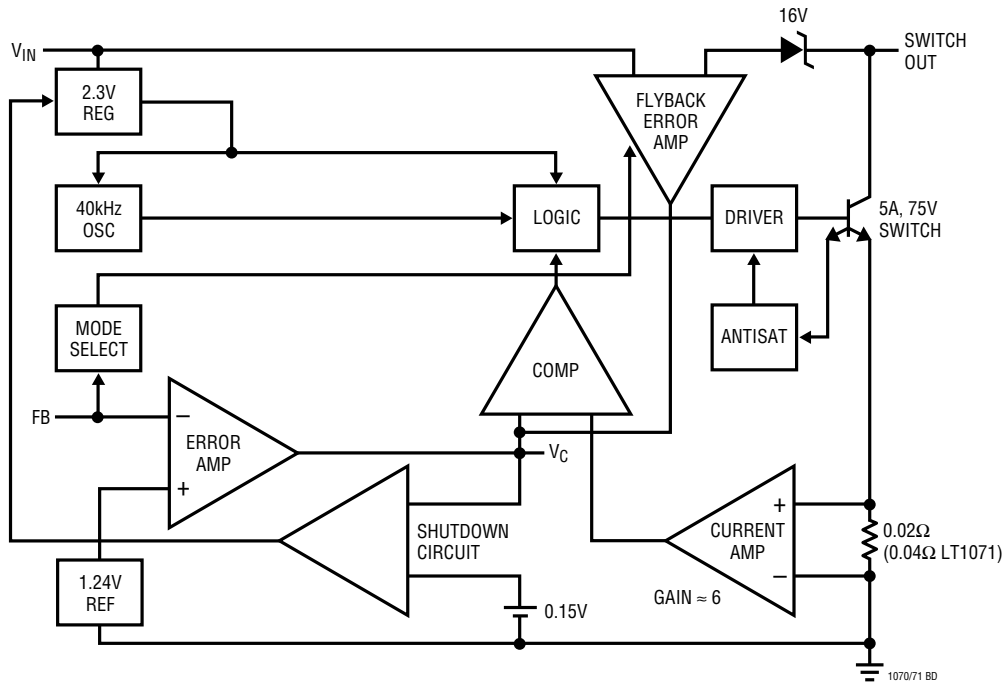

OPERATION

The LT1070/LT1071 is a current mode switcher. This means that switch duty cycle is directly controlled by switch current rather than by output voltage. Referring to the Block Diagram, the switch is turned "on" at the start of each oscillator cycle. It is turned "off" when switch current reaches a predetermined level. Control of output

voltage is obtained by using the output of a voltage sensing error amplifier to set current trip level. This technique has several advantages. First, it has immediate response to input voltage variations, unlike ordinary switchers which have notoriously poor line transient response. Second, it reduces the 90° phase shift at

OPERATION

midfrequencies in the energy storage inductor. This greatly simplifies closed-loop frequency compensation under widely varying input voltage or output load conditions. Finally, it allows simple pulse-by-pulse current limiting to provide maximum switch protection under output overload or short-circuit conditions. A low drop-out internal regulator provides a 2.3V supply for all internal circuitry of the LT1070/LT1071. This low drop-out design allows input voltage to vary from 3V to 60V with virtually no change in device performance. A 40kHz oscillator is the basic clock for all internal timing. It turns “on” the output switch via the logic and driver circuitry. Special adaptive antisat circuitry detects onset of saturation in the power switch and adjusts driver current instantaneously to limit switch saturation. This minimizes driver dissipation and provides very rapid turn-off of the switch.

A 1.2V bandgap reference biases the positive input of the error amplifier. The negative input is brought out for output voltage sensing. This feedback pin has a second function; when pulled low with an external resistor, it programs the LT1070/LT1071 to disconnect the main error amplifier output and connects the output of the flyback amplifier to the comparator input. The LT1070/LT1071 will then regulate the value of the flyback pulse with respect to the supply voltage. This flyback pulse is directly proportional to output voltage in the traditional

transformer coupled flyback topology regulator. By regulating the amplitude of the flyback pulse, the output voltage can be regulated with no direct connection between input and output. The output is fully floating up to the breakdown voltage of the transformer windings. Multiple floating outputs are easily obtained with additional windings. A special delay network inside the LT1070/LT1071 ignores the leakage inductance spike at the leading edge of the flyback pulse to improve output regulation.

The error signal developed at the comparator input is brought out externally. This pin (V_C) has four different functions. It is used for frequency compensation, current limit adjustment, soft starting and total regulator shutdown. During normal regulator operation this pin sits at a voltage between 0.9V (low output current) and 2.0V (high output current). The error amplifiers are current output (g_m) types, so this voltage can be externally clamped for adjusting current limit. Likewise, a capacitor coupled external clamp will provide soft start. Switch duty cycle goes to zero if the V_C pin is pulled to ground through a diode, placing the LT1070/LT1071 in an idle mode. Pulling the V_C pin below 0.15V causes total regulator shutdown, with only 50 μ A supply current for shutdown circuitry biasing. See AN19 for full application details.

TYPICAL APPLICATIONS (Note that maximum output currents are divided by 2 for the LT1071)

Driving High Voltage FET (for Off-Line Applications, See AN25)

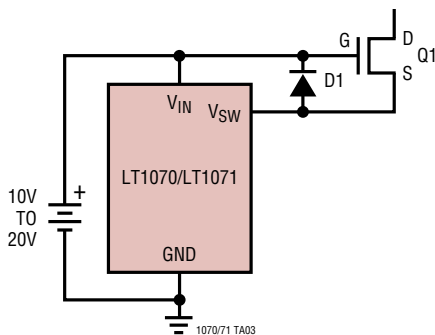

Driving High Voltage NPN

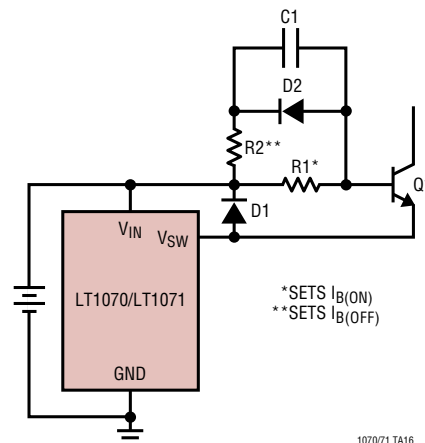

TYPICAL APPLICATIONS (Note that maximum output currents are divided by 2 for the LT1071)

Negative Buck Converter

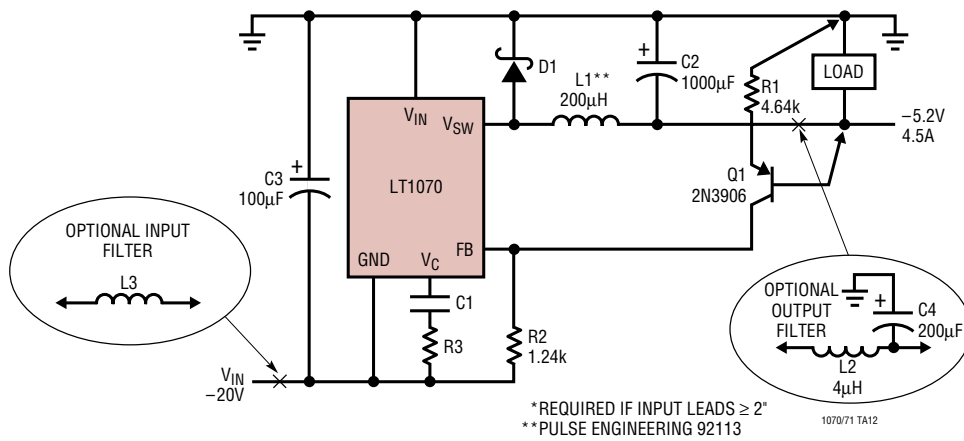

Positive Buck Converter

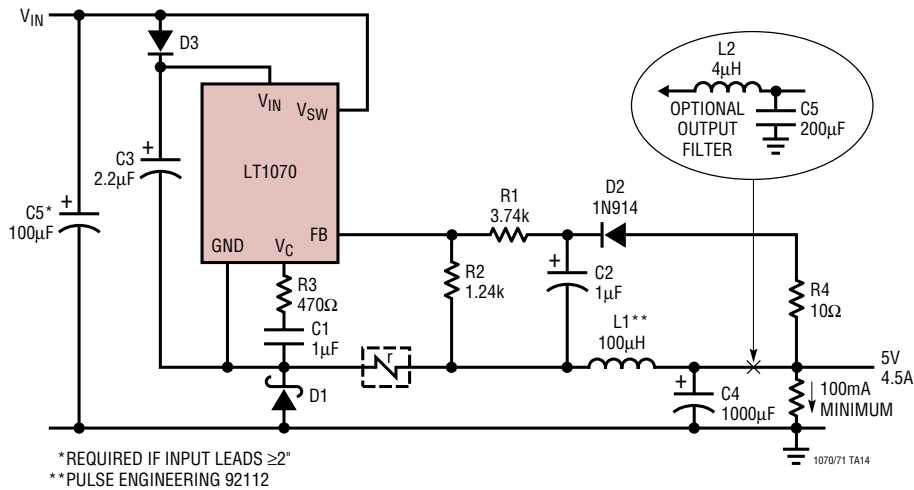

Negative Current Boosted Buck Converter

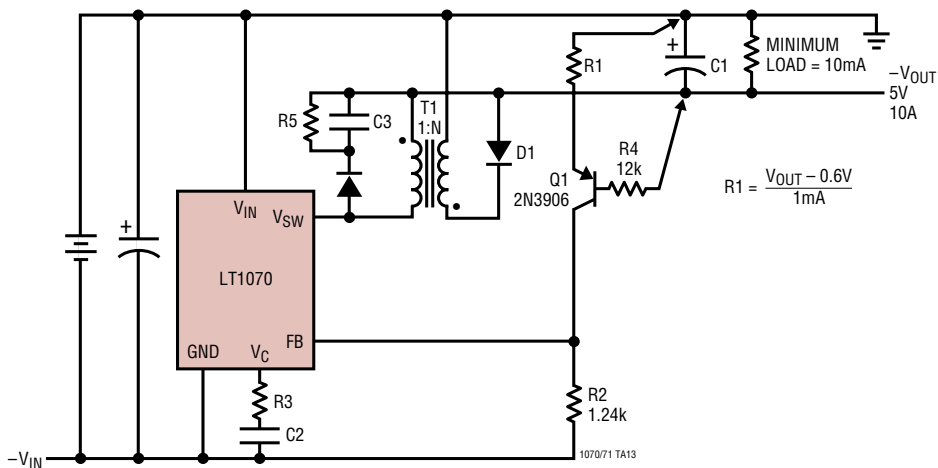

TYPICAL APPLICATIONS (Note that maximum output currents are divided by 2 for the LT1071)

Positive Current Boosted Buck Converter

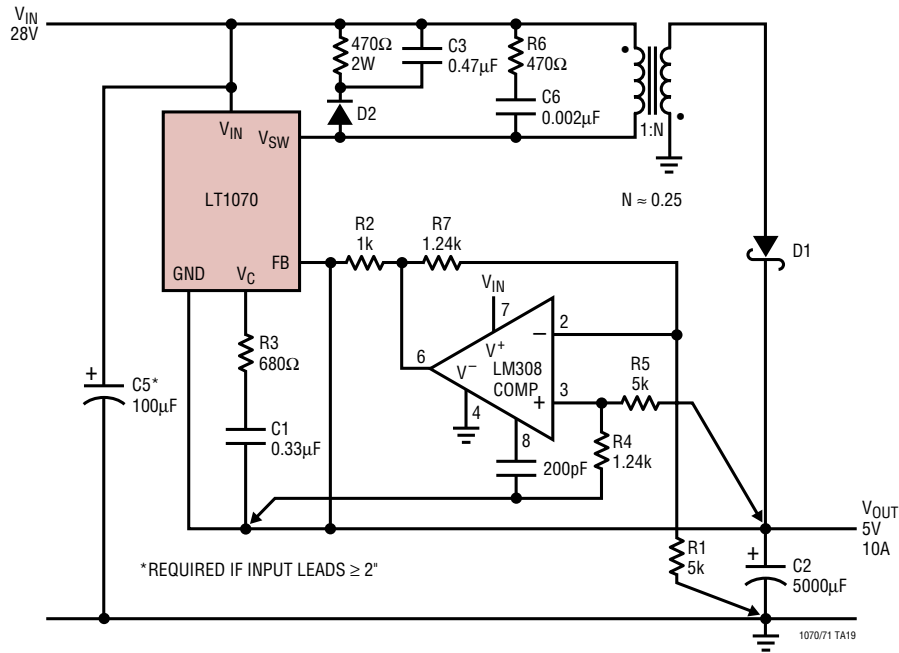

Negative to Positive Buck/Boost Converter

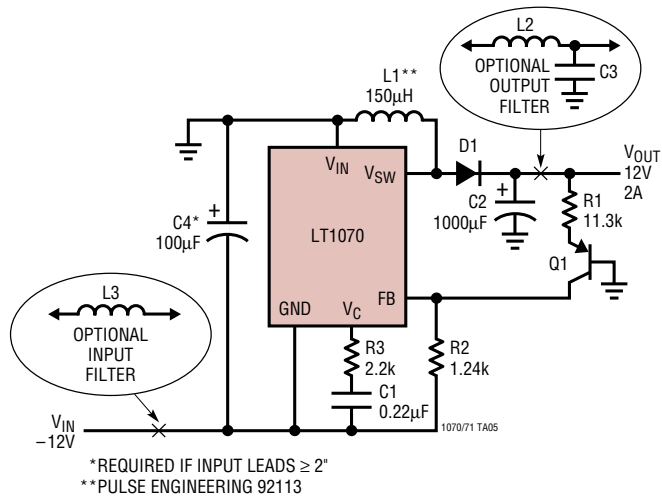

Positive to Negative Buck/Boost Converter

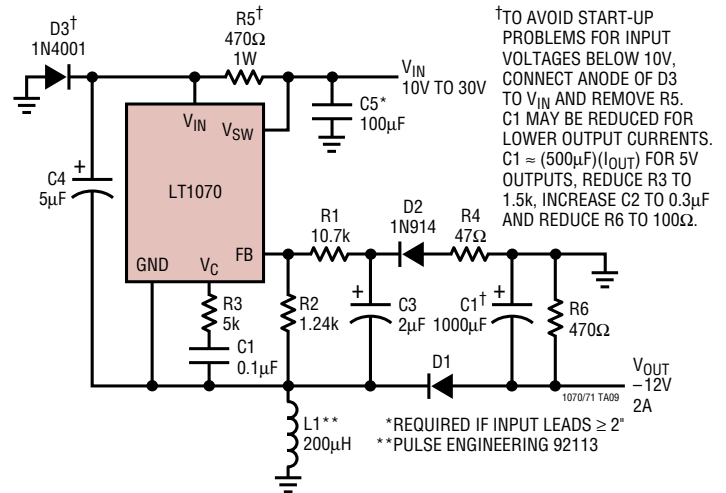

TYPICAL APPLICATIONS (Note that maximum output currents are divided by 2 for the LT1071)

Voltage Boosted Boost Converter

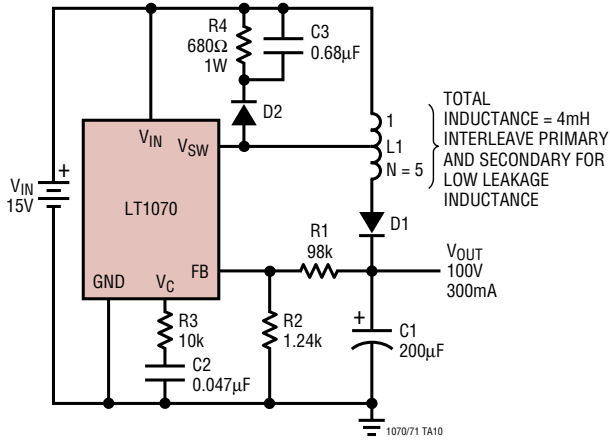

Current Boosted Boost Converter

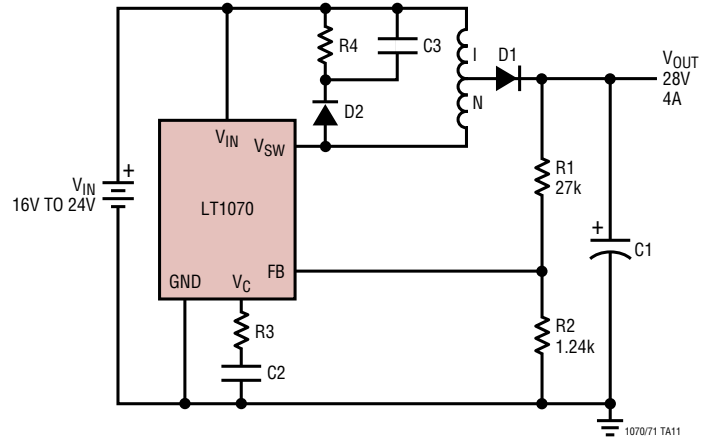

Negative Boost Regulator

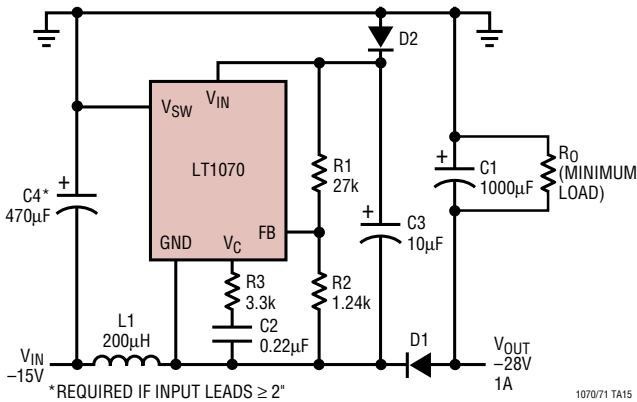

Negative Input/Negative Output Flyback Converter

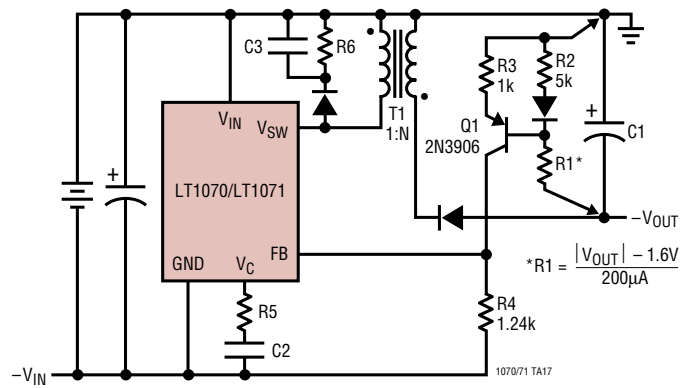

External Current Limit

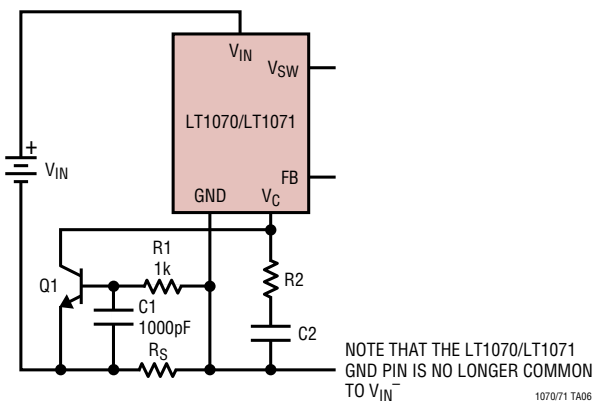

External Current Limit

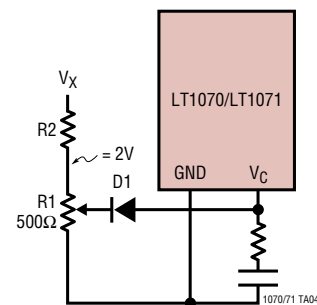

TYPICAL APPLICATIONS (Note that maximum output currents are divided by 2 for the LT1071)

Flyback Converter

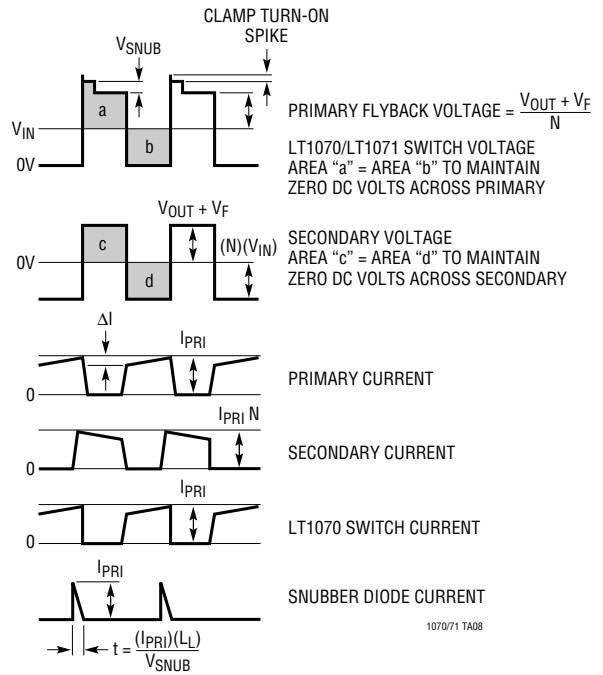
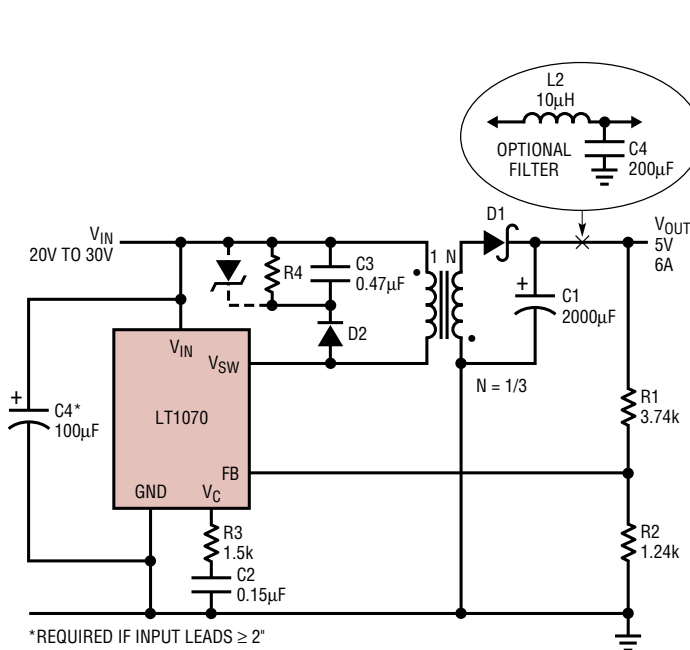

PACKAGE DESCRIPTION

K Package
4-Lead TO-3 Metal Can
(Reference LTC DWG # 05-08-1311)

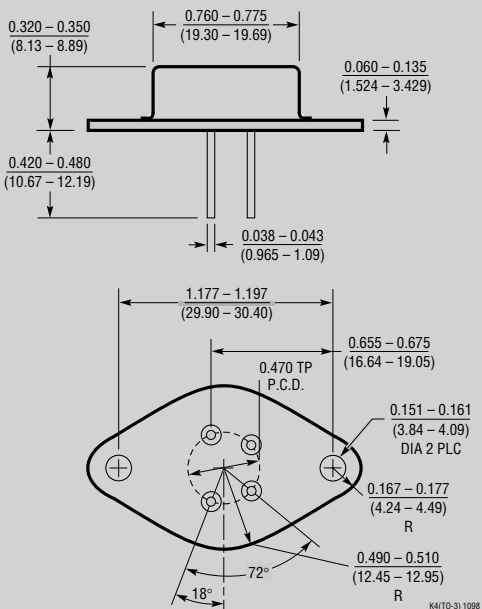

OBsolete PACKAGE

T Package
5-Lead Plastic TO-220 (Standard)
(Reference LTC DWG # 05-08-1421)

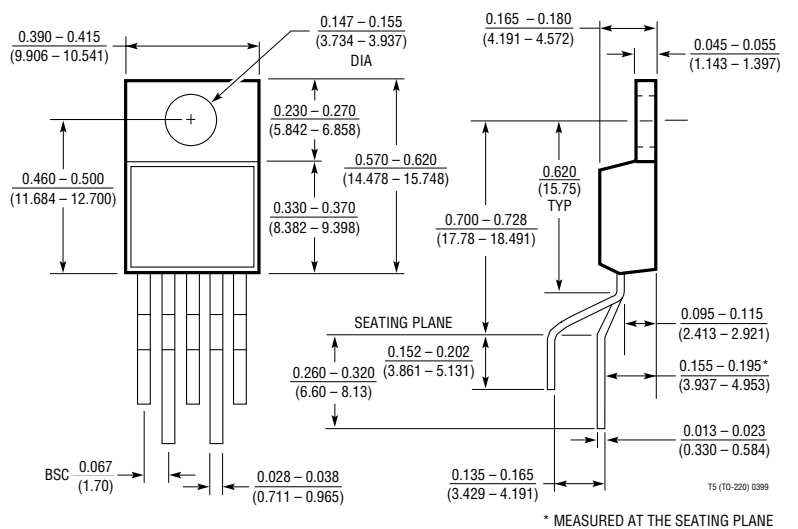

TYPICAL APPLICATIONS (Note that maximum output currents are divided by 2 for the LT1071)

Totally Isolated Converter

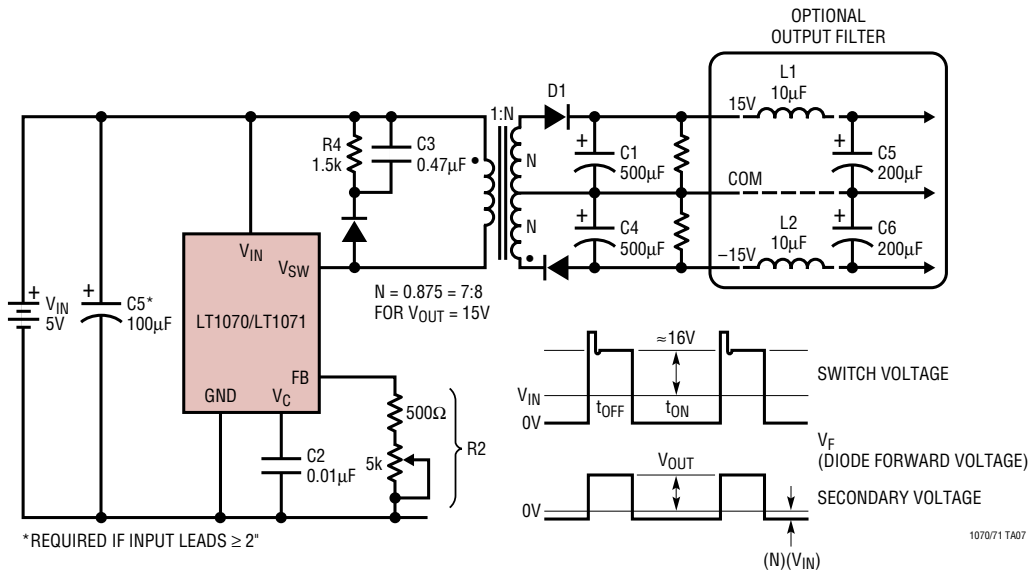

Forward Converter

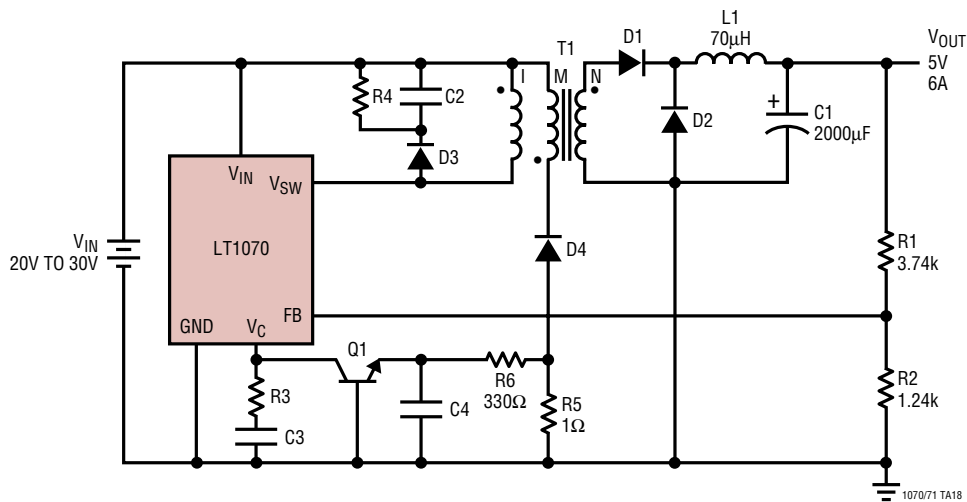

RELATED PARTS

PART NUMBER	DESCRIPTION	COMMENTS
LT1074/LT1076	High Voltage Switching Regulators	40V Input (60V for HV Versions), 100kHz, 5A and 2A
LT1170/LT1171/ LT1172	100kHz High Efficiency Switching Regulators	40V Input (65V for HV Versions), 5A/2.5A/1.25A Internal Switch
LT1370/LT1371	500kHz High Efficiency Switching Regulators	35V, 6A/3A Internal Switch
LT1374/LT1376	100kHz High Efficiency Switching Regulators	25V Input, 4.5A/1.5A Internal Switch
LT1765	1.25MHz, 3A, Step-Down Regulator	25V Input, TSSOP-16E, S08 Package

Looking for pricing, stock, or lifecycle information?

Click below to explore more details on WIN SOURCE:

 [View LT1071IT](#) on WIN SOURCE

 [Linear Technology](#) Information

Optimize Your Supply Chain with WIN SOURCE Solutions

-  Global Sourcing Solution
-  Obsolete Management
-  Cost Control Management
-  Shortage Management
-  Alternative Solution
-  Excess Inventory Management