



**THE DATASHEET OF  
LT1109CS8-12#TRPBF**



# Micropower Low Cost DC/DC Converter Adjustable and Fixed 5V, 12V

## FEATURES

- Uses Off-the-Shelf Inductors
- Only 33 $\mu$ H Inductor Required
- Low Cost
- 3-Lead TO-92, SO8, or 8-Pin DIP
- Adjustable or Fixed 5V or 12V Output
- 120kHz Oscillator
- Only Three External Components Required
- 320 $\mu$ A  $I_Q$
- 1.6V Minimum Start-Up Voltage
- Logic Controlled Shutdown

## APPLICATIONS

- Flash Memory VPP Generators
- 3V to 5V Converters
- 5V to 12V Converters
- Disk Drives
- PC Plug-In Cards
- Peripherals
- Battery-Powered Equipment

## DESCRIPTION

The LT1109 is a simple step-up DC/DC converter. Available in 8-pin SO, 3-lead TO-92 (fixed output only) or miniDIP packages, the devices require only three external components to construct a complete DC/DC converter. Current drain is just 320 $\mu$ A at no load, making the device ideal for cost-sensitive applications where standby current must be kept to a minimum.

The LT1109-5 can deliver 5V at 100mA from a 3V input and the LT1109-12 can deliver 12V at 60mA from a 5V input. The 8-pin versions also feature a logic controlled **SHUTDOWN** pin that turns off the oscillator when taken low. The gated-oscillator design requires no frequency compensation components. The high frequency 120kHz oscillator permits the use of small surface mount inductors and capacitors. For a 5V to 12V at 120mA converter, see the LT1109A. For a 5V to 12V at 200mA converter with 20 $\mu$ A shutdown current, see the LT1301.

## TYPICAL APPLICATION

### All Surface Mount Flash Memory VPP Generator

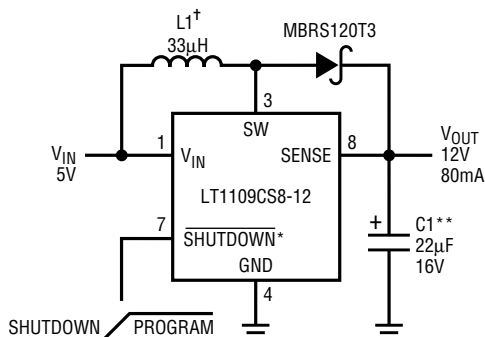

\* 8-PIN PACKAGE ONLY

† L1 = SUMIDA CD54-330LC ( $I_{OUT} = 80mA$ )  
 COILTRONICS CTX33-1 (80mA)

MURATA-ERIE LQH4N330K ( $I_{OUT} = 50mA$ )  
 ISI LCS2414-330K ( $I_{OUT} = 50mA$ )

\*\*C1 = MATSUO 267M1602226 OR EQUIVALENT

LT1109 • TA01

### Output Voltage

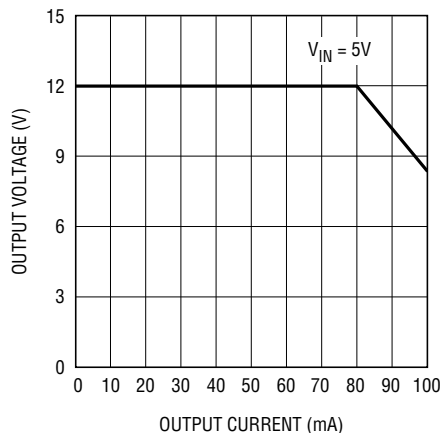

LT1109 • TPC01

### Flash Memory Program Output

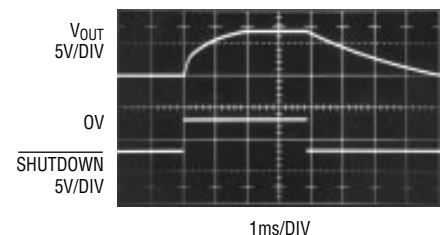

LT1109 • TA02

## ABSOLUTE MAXIMUM RATINGS

(Voltages Referred to GND Pin)

Supply Voltage ( $V_{OUT}$ ) .....	-0.4V to 20V	Operating Temperature Range .....	0°C to 70°C
SW Pin Voltage .....	-0.4V to 50V	Storage Temperature Range .....	-65°C to 150°C
SHUTDOWN Pin Voltage .....	6.0V	Lead Temperature (Soldering, 10 sec.) .....	300°C
Maximum Power Dissipation .....	300mW	Switch Current .....	1.2A

## PACKAGE/ORDER INFORMATION

<p>N8 PACKAGE 8-LEAD PLASTIC DIP LT1109 • P0102 <math>T_{JMAX} = 100^{\circ}C, \theta_{JA} = 130^{\circ}C/W</math></p>	<p>S8 PACKAGE 8-LEAD PLASTIC SOIC LT1109 • P0103 <math>T_{JMAX} = 100^{\circ}C, \theta_{JA} = 150^{\circ}C/W</math></p>	<p>Z PACKAGE 3-LEAD TO-92 PLASTIC LT1109 • P0101 <math>T_{JMAX} = 100^{\circ}C, \theta_{JA} = 160^{\circ}C/W</math></p>	
ORDER PART NUMBER	ORDER PART NUMBER	S8 PART MARKING	ORDER PART NUMBER
LT1109CN8 LT1109CN8-5 LT1109CN8-12	LT1109CS8 LT1109CS8-5 LT1109CS8-12	1109 10905 10912	LT1109CZ-5 LT1109CZ-12

## ELECTRICAL CHARACTERISTICS $T_A = 25^{\circ}C, V_{IN} = 3V$ (LT1109CN8, LT1109CS8), unless otherwise specified.

SYMBOL	PARAMETER	CONDITIONS	MIN	TYP	MAX	UNITS	
$I_Q$	Quiescent Current	Switch Off	●	320	550	$\mu A$	
	Minimum Start-Up Voltage at $V_{OUT}$ Pin (Z Package)		1.6			V	
$V_{IN}$	Input Voltage (N8, S8 Package)		●	3		V	
	Comparative Trip Point Voltage	LT1109	●	1.20	1.25	1.30	V
$V_{OUT}$	Output Voltage	LT1109-5; $3V \leq V_{IN} \leq 5V$ LT1109-12; $3V \leq V_{IN} \leq 12V$	●	4.75	5.00	5.25	V
	Comparator Hysteresis	LT1109	●		8	12.5	mV
	Output Voltage Ripple	LT1109-5 LT1109-12	●		25	50	mV
			●		60	120	mV
$f_{OSC}$	Oscillator Frequency		●	100	120	140	kHz
			●	90		150	kHz
$t_{ON}$	Switch ON Time		●	3.3	4.2	5.3	$\mu s$
			●	3.0		5.5	$\mu s$
DC	Duty Cycle	Full Load	●	45	50	60	%
$V_{CESAT}$	Switch Saturation Voltage	$I_{SW} = 500mA$ LT1109-5: $V_{IN} = 3V$ ; LT1109-12: $V_{IN} = 5V$	●		0.4	0.7	V
			●		0.5	0.8	V

**ELECTRICAL CHARACTERISTICS**  $T_A = 25^\circ\text{C}$ ,  $V_{IN} = 3\text{V}$  (LT1109CN8, LT1109CS8), unless otherwise specified.

SYMBOL	PARAMETER	CONDITIONS	MIN	TYP	MAX	UNITS
	Switch Leakage Current	$V_{SW} = 12\text{V}$		1	10	$\mu\text{A}$
$V_{IH}$	SHUTDOWN Pin High	N8, S8 Package ●	2.0			V
$V_{IL}$	SHUTDOWN Pin Low	N8, S8 Package ●			0.8	V
$I_{IH}$	SHUTDOWN Pin Input Current	N8, S8 Package, $V_{SHUTDOWN} = 4\text{V}$ ●			10	$\mu\text{A}$
$I_{IL}$	SHUTDOWN Pin Input Current	N8, S8 Package, $V_{SHUTDOWN} = 0\text{V}$ ●			20	$\mu\text{A}$

The ● denotes the specifications which apply over the full operating temperature range.

**TYPICAL PERFORMANCE CHARACTERISTICS**

Oscillator Frequency

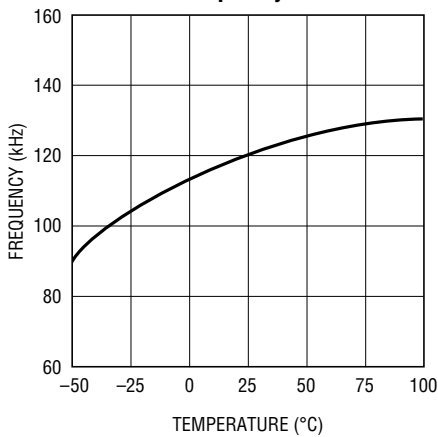

Oscillator Frequency

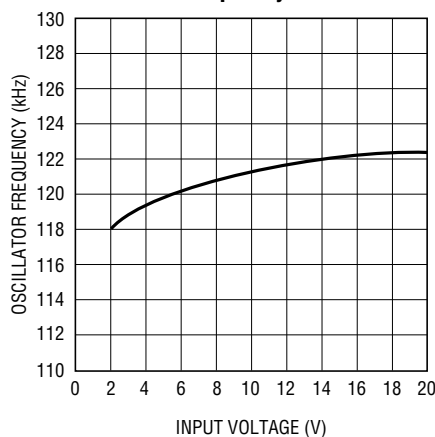

Switch ON Time

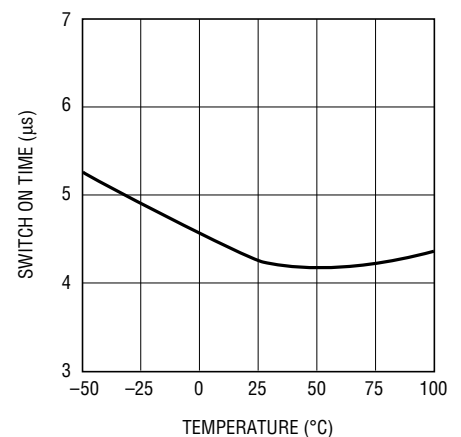

Duty Cycle

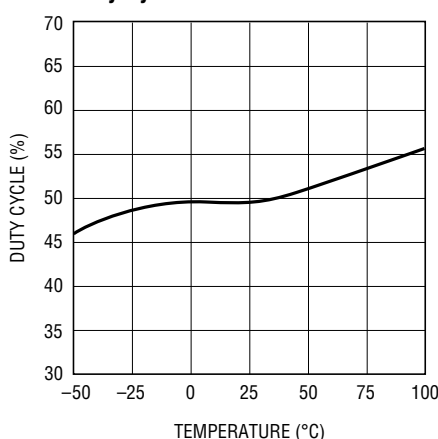

Switch Saturation Voltage

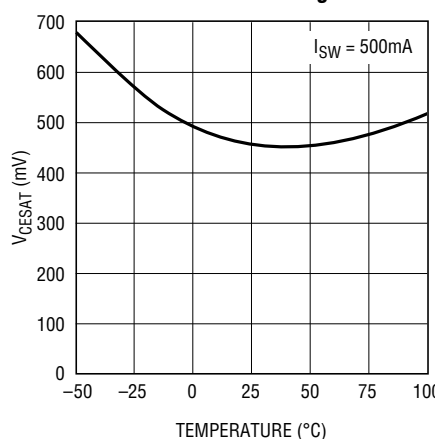

Switch Saturation Voltage

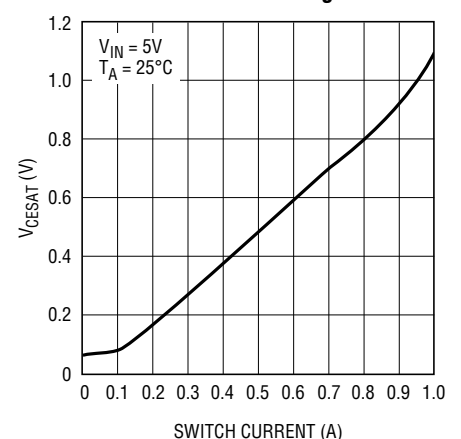

# TYPICAL PERFORMANCE CHARACTERISTICS

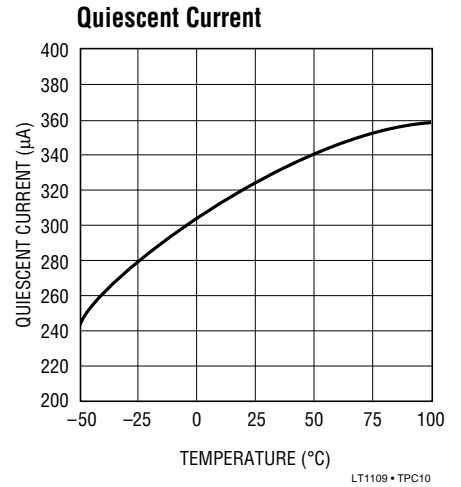
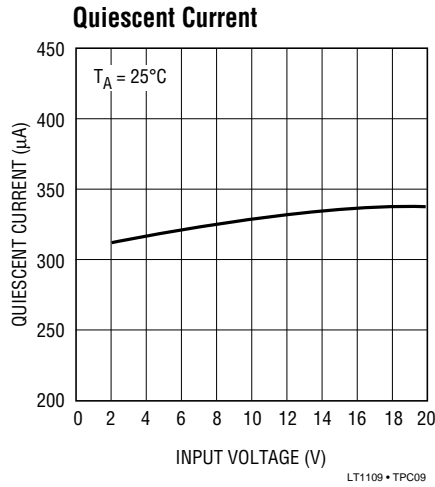
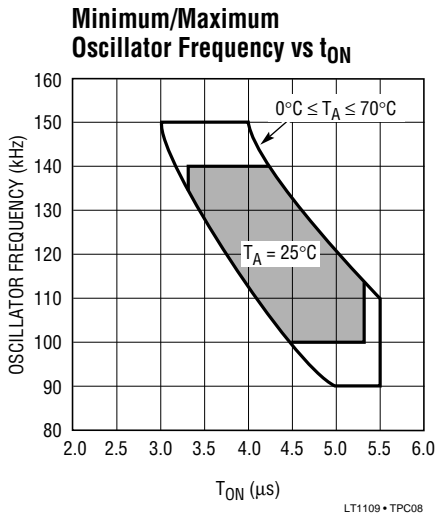

## BLOCK DIAGRAMS

LT1109-5, -12 Z Package

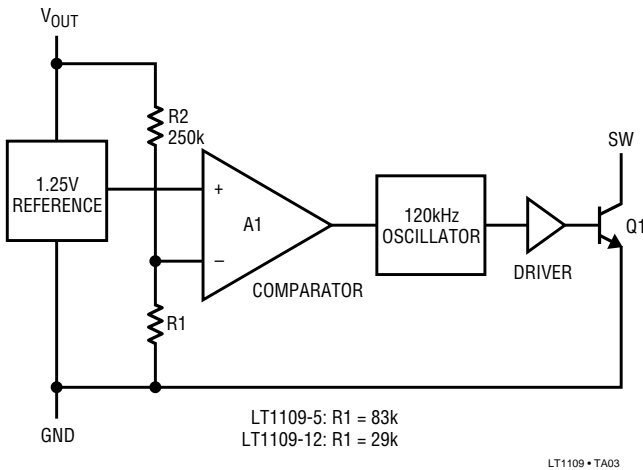

LT1109-5, -12 N8, S8 Package

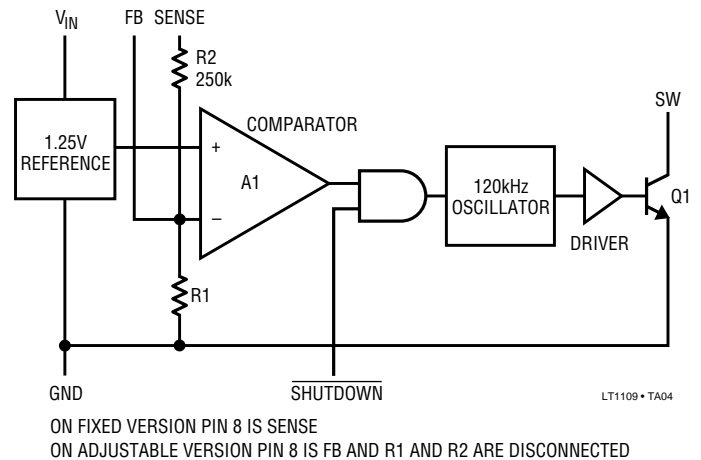

## LT1109Z OPERATION

The LT1109Z-5 and LT1109Z-12 are fixed output voltage step-up DC/DC converters in a 3-pin TO-92 package. Power for internal regulator circuitry is taken from the  $V_{OUT}$  pin, a technique known as “bootstrapping.” Circuit operation can be best understood by referring to the block diagram.  $V_{OUT}$ , attenuated by R1 and R2, is applied to the negative input of comparator A1. When this voltage falls below the 1.25V reference voltage, the oscillator is turned on and the power switch Q1 cycles at the oscillator

frequency of 120kHz. Switch cycling alternately builds current in the inductor, then dumps it into the output capacitor, increasing the output voltage. When A1’s negative input rises above 1.25V, it turns off the oscillator. A small amount of hysteresis in A1 obviates the need for frequency compensation circuitry. When Q1 is off, current into the  $V_{OUT}$  pin drops to just  $320\mu A$ . Quiescent current from the battery will be higher because the device operates off the *stepped-up* voltage.

## LT1109 S8 AND N8 OPERATION

The 8-pin versions of the LT1109 have separate pins for  $V_{IN}$  and SENSE or FB and also have a SHUTDOWN pin. Separating the device  $V_{IN}$  pin from the SENSE pin allows the device to be powered from the (lower) input voltage rather than the (higher) output voltage. Although quiescent *current* remains constant, quiescent *power* will be

reduced by using the 8-pin version since the quiescent current flows from a lower voltage source. The SHUTDOWN pin disables the oscillator when taken to a logic "0." If left floating or tied high, the converter operates normally. With SHUTDOWN low, quiescent current remains at 320 $\mu$ A.

## APPLICATIONS INFORMATION

### Inductor Selection

A DC/DC converter operates by storing energy as magnetic flux in an inductor core, and then switching this energy into the load. To operate as an efficient energy transfer element, the inductor must fulfill three requirements. First, the inductance must be low enough for the inductor to store adequate energy under the worst case condition of minimum input voltage and switch-ON time. The inductance must also be high enough so that maximum current ratings of the LT1109 and inductor are not exceeded at the other worst case condition of maximum input voltage and ON time. Additionally, the inductor core must be able to store the required flux; i.e., it must not *saturate*. At power levels generally encountered with LT1109 designs, small ferrite surface-mount inductors will function well. Lastly, the inductor must have sufficiently low DC resistance so that excessive power is not lost as heat in the windings. Look for DCR values in the inductors' specification tables; values under 0.5 $\Omega$  will give best efficiency. An additional consideration is Electro-Magnetic Interference (EMI). Toroid and pot core type inductors are recommended in applications where EMI must be kept to a minimum; for example, where there are sensitive analog circuitry or transducers nearby. Rod core types are a less expensive choice where EMI is not a problem.

Specifying a proper inductor for an application requires first establishing minimum and maximum input voltage, output voltage, and output current. In a step-up converter, the inductive events add to the input voltage to produce the output voltage. Power required from the inductor is determined by

$$P_L = (V_{OUT} + V_D - V_{IN}) (I_{OUT}) \quad (01)$$

where  $V_D$  is the diode drop (0.5V for a 1N5818 Schottky). Energy required by the inductor per cycle must be equal or greater than

$$\frac{P_L}{F_{OSC}} \quad (02)$$

in order for the converter to regulate the output.

When the switch is closed, current in the inductor builds according to

$$I_L(t) = \frac{V_{IN}}{R'} \left( 1 - e^{-\frac{R't}{L}} \right) \quad (03)$$

where  $R'$  is the sum of the switch equivalent resistance (0.8 typical at 25°C) and the inductor DC resistance. When the drop across the switch is small compared to  $V_{IN}$ , the simple lossless equation

$$I_L(t) = \frac{V_{IN}}{L} t \quad (04)$$

can be used. These equations assume that at  $t = 0$ , inductor current is zero. This situation is called "discontinuous mode operation" in switching regulator parlance. Setting "t" to the switch-ON time from the LT1109 specification table (typically 4.2 $\mu$ s) will yield  $I_{PEAK}$  for a specific "L" and  $V_{IN}$ . Once  $I_{PEAK}$  is known, energy in the inductor at the end of the switch-ON time can be calculated as

$$E_L = \frac{1}{2} L I_{PEAK}^2 \quad (05)$$

$E_L$  must be greater than  $P_L/F_{OSC}$  for the converter to deliver the required power. For best efficiency  $I_{PEAK}$  should be

## APPLICATIONS INFORMATION

kept to 600mA or less. Higher switch currents will cause excessive drop across the switch resulting in reduced efficiency. In general, switch current should be held to as low a value as possible in order to keep switch, diode and inductor losses at a minimum.

As an example, suppose 12V at 60mA is to be generated from a 4.5V input. Recalling Equation 01,

$$P_L = (12V + 0.5V - 4.5V) (60mA) = 480mW. \quad (06)$$

Energy required from the inductor is

$$\frac{P_L}{F_{OSC}} = \frac{480mW}{120kHz} = 4.0\mu J. \quad (07)$$

Picking an inductor value of 33μH with 0.2Ω DCR results in a peak switch current of

$$I_{PEAK} = \frac{4.5V}{1.0\Omega} \left( 1 - e^{-\frac{1.0 \cdot 4.2\mu s}{33\mu H}} \right) = 538mA. \quad (08)$$

Substituting  $I_{PEAK}$  into Equation 03 results in

$$E_L = \frac{1}{2} (33\mu H)(0.538A)^2 = 4.77\mu J. \quad (09)$$

Since 4.77μJ > 4μJ the 33μH inductor will work. This trial-and-error approach can be used to select the optimum inductor. Keep in mind the switch current maximum rating of 1.2A. If the calculated peak current exceeds this, the input voltage must be increased or the load decreased.

### Capacitor Selection

The output capacitor should be chosen on the basis of its equivalent series resistance (ESR). Surface-mount tantalum electrolytics can be used provided the ESR value is sufficiently low. An ESR of 0.1Ω will result in a 50mV step at the output of the converter when the peak inductor current is 500mA. Physically larger capacitors have lower ESR.

### Diode Selection

Speed, forward drop, and leakage current are the three main considerations in selecting a catch diode for LT1109 converters. General purpose rectifiers such as the 1N4001

are *unsuitable* for use in *any* switching regulator application. Although they are rated at 1A, the switching time of a 1N4001 is in the 10μs-50μs range. At best, efficiency will be severely compromised when these diodes are used; at worst, the circuit may not work at all. Most LT1109 circuits will be well served by a 1N5818 Schottky diode. The combination of 500mV forward drop at 1A current, fast turn-ON and turn-OFF time, and 4μA to 10μA leakage current fit nicely with LT1109 requirements. At peak switch currents of 100mA or less, a 1N4148 signal diode may be used. This diode has leakage current in the 1nA to 5nA range at 25°C and lower cost than a 1N5818.

**Table 1. Inductor Manufacturers**

MANUFACTURER	PART NUMBERS
Caddell-Burns 258 East Second Street Mineola, NY 11501 516-746-2310	7120 Series
Coiltronics Incorporated 6000 Park of Commerce Blvd. Boca Raton, FL 33487 407-241-7876	Surface Mount CTX33-1
Coilcraft 1102 Silver Lake Road Cary, IL 60013 708-639-6400	DT3316 Series
Sumida Electric Co., Ltd. 637 E. Golf Road, Suite 209 Arlington Heights, IL 60005 708-956-0666	CD54 CD105 Surface Mount

**Table 2. Capacitor Manufacturers**

MANUFACTURER	PART NUMBERS
Sanyo Video Components 2001 Sanyo Avenue San Diego, CA 92173 619-661-6835	OS-CON Series
Matsuo Electronics 2134 Main Street, Suite 200 Huntington Beach, CA 92648 714-969-2491	267 Series
Kemet Electronics Corporation Box 5928 Greenville, SC 29606 803-963-6621	T491 Series
Philips Components 2001 W. Blue Heron Blvd. P.O. Box 10330 Riviera Beach, FL 33404 407-881-3200	49MC Series

# TYPICAL APPLICATIONS

### 3-Pin Package Flash Memory VPP Generator

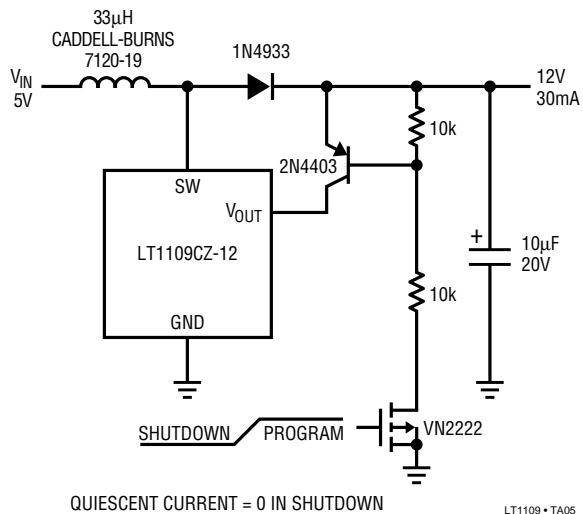

### 3V to 5V Converter

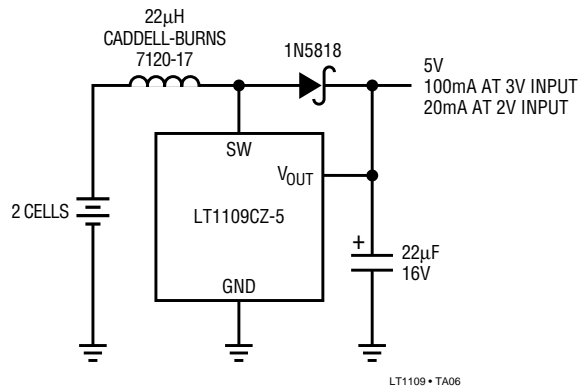

### 3V to 12V Converter

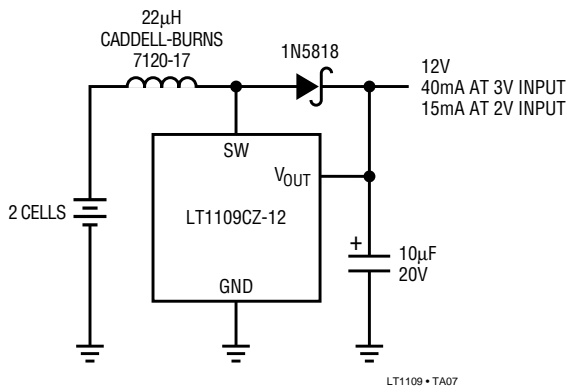

### 3V to 5V Converter with Shutdown

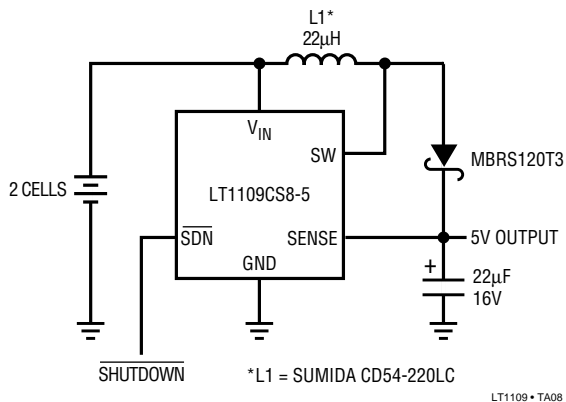

**PACKAGE DESCRIPTION** Dimensions in inches (millimeters) unless otherwise noted.

**N8 Package  
8-Lead Plastic DIP**

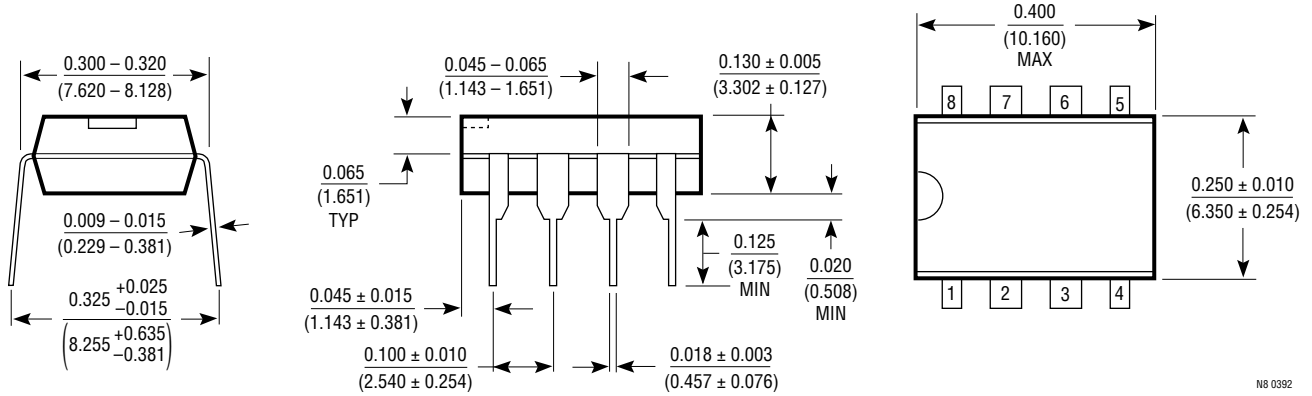

**S8 Package  
8-Lead Plastic SOIC**

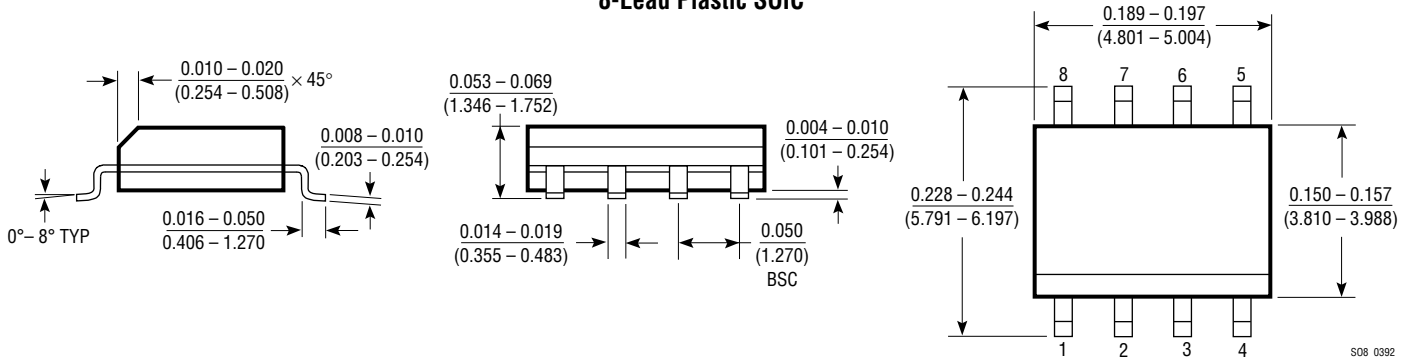

**Z Package  
3-Lead TO-92 Plastic**

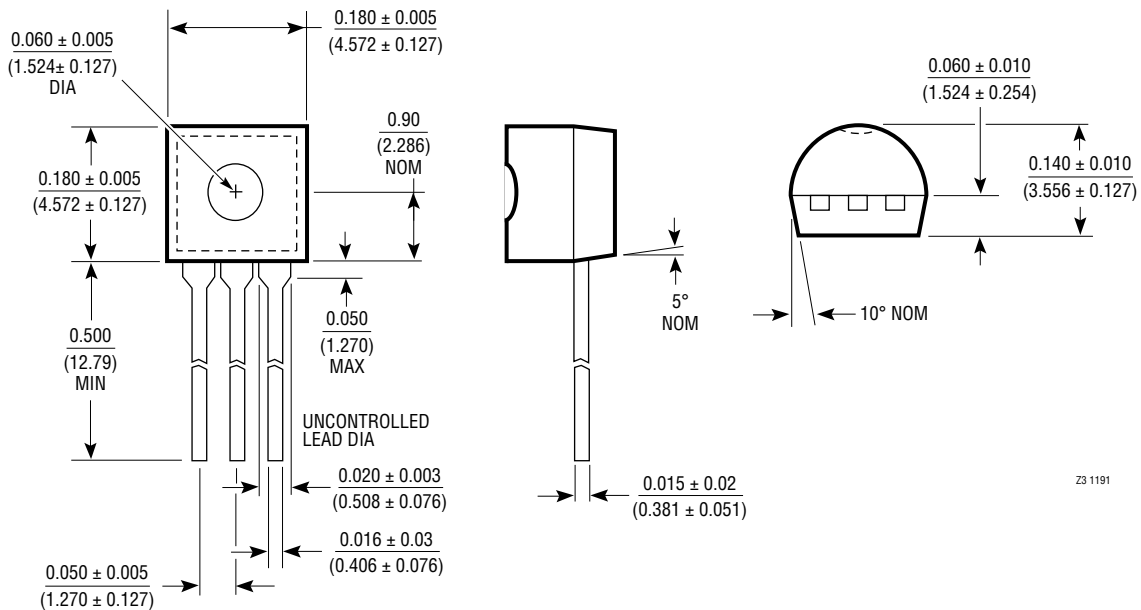

## Looking for pricing, stock, or lifecycle information?

Click below to explore more details on WIN SOURCE:

 [View LT1109CS8-12#TRPBF on WIN SOURCE](#)

 [Linear Technology](#) Information

## Optimize Your Supply Chain with WIN SOURCE Solutions

-  Global Sourcing Solution
-  Obsolete Management
-  Cost Control Management
-  Shortage Management
-  Alternative Solution
-  Excess Inventory Management