



**THE DATASHEET OF
LT1176CN8-5**



FEATURES

- 1.2A Onboard Switch
- 100kHz Switching Frequency
- Excellent Dynamic Behavior
- DIP and Surface Mount Packages
- Only 8mA Quiescent Current
- Preset 5V Output Available
- Operates Up to 35V Input
- Micropower Shutdown Mode

APPLICATIONS

- Buck Converter with Output Voltage Range of 2.5V to 30V
- Positive-to-Negative Converter
- Negative Boost Converter
- Multiple Output Buck Converter

DESCRIPTION

The LT[®]1176 is a 1A monolithic bipolar switching regulator which requires only a few external parts for normal operation. The power switch, all oscillator and control circuitry

and all current limit components are included on the chip. The topology is a classic positive buck configuration but several design innovations allows this device to be used as a positive-to-negative converter, a negative boost converter, and as a flyback converter. The switch output is specified to swing below ground.

The LT1176 uses a true analog multiplier in the feedback loop. This makes the device respond nearly instantaneously to input voltage fluctuations and makes loop gain independent of input voltage. As a result, dynamic behavior of the regulator is significantly improved over previous designs.

On-chip pulse by pulse current limiting makes the LT1176 nearly bust proof for output overloads or shorts. The input voltage range as a buck converter is 8V to 35V, but a self boot feature allows input voltages as low as 5V in the inverting and boost configurations.

The LT1176 is available in a low cost 8-lead DIP package with frequency preset at 100kHz and current limit at 1.7A. An adjustable output is offered as well as a preset 5V version. For further design details and application help, see the LT1074/LT1076 data sheet and Application Note 44.

LT, LT, LTC, LTM, Linear Technology, SwitcherCAD and the Linear logo are registered trademarks of Linear Technology Corporation. All other trademarks are the property of their respective owners.

TYPICAL APPLICATION

Basic 5V Positive Buck Converter

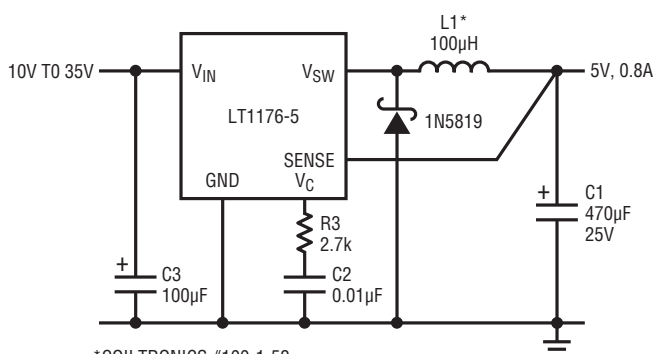

*COILTRONICS #100-1-52
 PULSE ENGINEERING, INC. #PE-92102
 HURRICANE #HL-AG210LL
 THESE ARE LOW COST POWDERED IRON CORES. OPTIMUM EFFICIENCY AND SMALLEST SIZE IS OBTAINED BY USING A LOW LOSS CORE SUCH AS MAGNETICS INC. KOOL Mµ. SEE EFFICIENCY GRAPH.

5V Buck Converter Efficiency

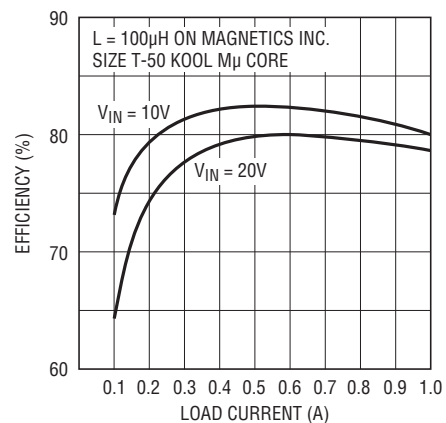

11765 TA02

LT1176/LT1176-5

ABSOLUTE MAXIMUM RATINGS

(Note 1)

Input Voltage.....	38V
Switch Voltage with Respect to Input Voltage.....	50V
Switch Voltage with Respect to Ground Pin (V _{SW} Negative) (Note 7).....	20V
Feedback Pin Voltage.....	-2V, 10V
Shutdown Pin Voltage (Not to Exceed V _{IN}).....	35V
Status Pin Voltage (Current Must Be Limited to 5mA When Status Pin Switches ON).....	30V

I _{LIM} Pin Voltage (Forced).....	5.5V
Maximum Operating Ambient Temperature Range LT1176C/LT1176C-5.....	0°C to 70°C
Maximum Operating Junction Temperature Range LT1176C/LT1176C-5.....	0°C to 125°C
Storage Temperature Range.....	-65°C to 150°C
Lead Temperature (Soldering, 10 sec).....	300°C

*These thermal resistance numbers are for typical mounting technique. Lower thermal resistance can be obtained with large copper lands, thermal glues or heat sinks.

PIN CONFIGURATION

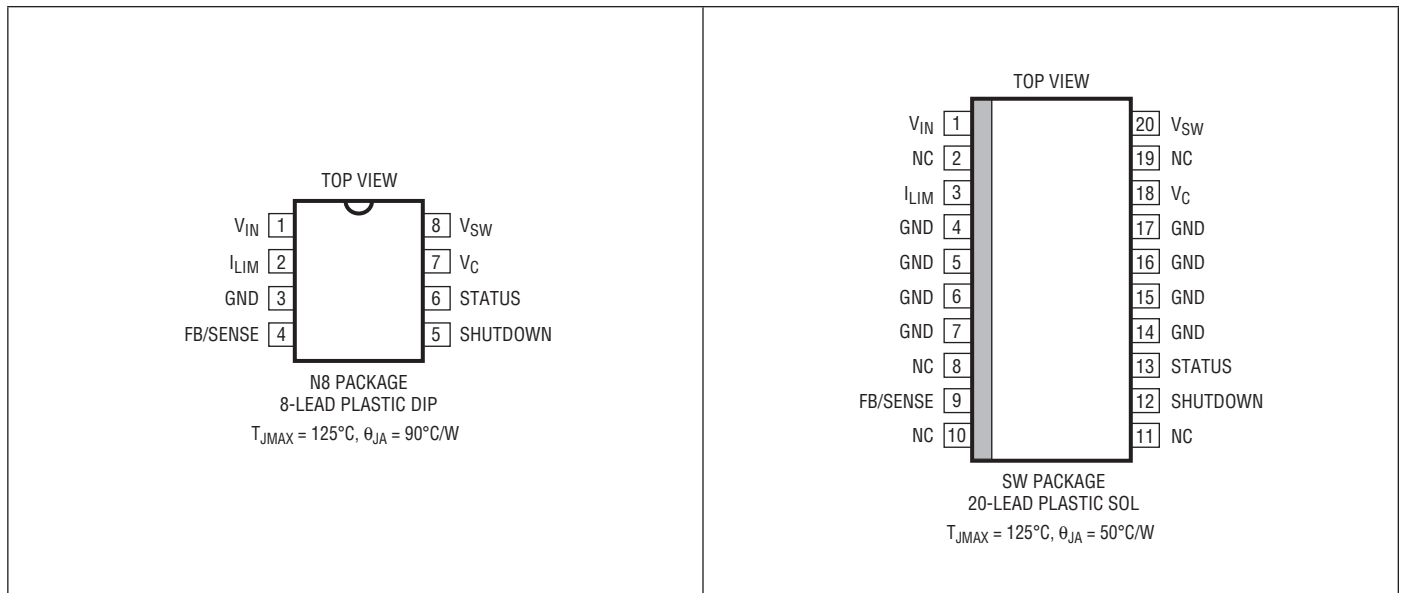

ORDER INFORMATION

LEAD FREE FINISH	TAPE AND REEL	PART MARKING*	PACKAGE DESCRIPTION	TEMPERATURE RANGE
LT1176CN8#PBF		LT1176CN8	8-Lead Plastic DIP	0°C to 125°C
LT1176CN8-5#PBF		LT1176CN8-5	8-Lead Plastic DIP	0°C to 125°C
LT1176CSW#PBF	LT1176CSW#TRPBF	LT1176CSW	20-Lead Plastic SOL	0°C to 125°C
LT1176CSW-5#PBF	LT1176CSW-5#TRPBF	LT1176CSW-5	20-Lead Plastic SOL	0°C to 125°C

Consult LTC Marketing for parts specified with wider operating temperature ranges. *The temperature grade is identified by a label on the shipping container.

For more information on lead free part marking, go to: <http://www.linear.com/leadfree/>

For more information on tape and reel specifications, go to: <http://www.linear.com/tapeandreeel/>

ELECTRICAL CHARACTERISTICS The ● denotes the specifications which apply over the full operating temperature range, otherwise specifications are at $T_A = 25^\circ\text{C}$, $T_J = 25^\circ\text{C}$, $V_{IN} = 25\text{V}$, unless otherwise noted.

PARAMETER	CONDITIONS	MIN	TYP	MAX	UNITS	
Switch ON Voltage (Note 2)	$I_{SW} = 0.2\text{A}$	●		1.1	V	
	$I_{SW} = 1\text{A}$	●		1.4	V	
Switch OFF Leakage	$V_{IN} = 25\text{V}$, $V_{SW} = 0$			150	μA	
	$V_{IN} = V_{MAX}$, $V_{SW} = 0$ (Note 8)			250	μA	
Supply Current (Note 3)	$V_{FB} = 2.5\text{V}$, $V_{IN} \leq 35\text{V}$	●	7.5	10	mA	
	$V_{SHDN} = 0.1\text{V}$ (Device Shutdown) (Note 9)	●	140.0	300	μA	
Minimum Supply Voltage	Normal Mode	●	7.3	8.0	V	
	Startup Mode (Note 4)	●	3.5	4.8	V	
Switch Current Limit (Note 5)	I_{LIM} Open	●	1.2	1.7	A	
	$R_{LIM} = 10\text{k}$ (Note 6)			1.2	A	
	$R_{LIM} = 7\text{k}$ (Note 6)			0.8	A	
Maximum Duty Cycle		●	85	90	%	
Switching Frequency		●	90	100	110	kHz
		●	85		120	kHz
	$V_{FB} = 0\text{V}$ Through 2k (Note 5) (LT1176)			20		kHz
	$V_{SENSE} = 0\text{V}$ (Note 5) (LT1176-5)			20		kHz
Switching Frequency Line Regulation	$8\text{V} \leq V_{IN} \leq V_{MAX}$ (Note 8)	●		0.03	0.1	%/V
Error Amplifier Voltage Gain (Note 10)	$1\text{V} \leq V_C \leq 4\text{V}$			2000		V/V
Error Amplifier Transconductance (Note 10)			3700	5000	8000	μmho
Error Amplifier Source and Sink Current	Source ($V_{FB} = 2\text{V}$ or $V_{SENSE} = 4\text{V}$)		100.0	140	225.0	μA
	Sink ($V_{FB} = 2.5\text{V}$ or $V_{SENSE} = 5.5\text{V}$)		0.7	1.0	1.6	mA
Feedback Pin Bias Current (LT1176)	$V_{FB} = V_{REF}$	●		0.5	2	μA
Reference Voltage (LT1176)	$V_C = 2\text{V}$	●	2.155	2.21	2.265	V
Reference Voltage Tolerance (LT1176)	V_{REF} (Nominal) = 2.21V			± 0.5	± 2	%
	All Conditions of Input Voltage, Output Voltage, Temperature and Load Current	●		± 1.0	± 3	%
Sense Voltage (LT1176-5)	$V_C = 2\text{V}$	●	4.85	5	5.15	V
Sense Voltage Tolerance (LT1176-5)	V_{OUT} (Nominal) = 5V			± 0.5	± 2	%
	All Conditions of Input Voltage, Temperature and Load Current	●		± 0.1	± 3	%
Sense Pin Divider Resistance (LT1176-5)			3	5	8	$\text{k}\Omega$
Output Voltage Line Regulation	$8\text{V} \leq V_{IN} \leq V_{MAX}$ (Note 8)	●		0.005	0.02	%/V
V_C Voltage at 0% Duty Cycle				1.5		V
	Overtemperature	●		-4.0		$\text{mV}/^\circ\text{C}$
Multiplier Reference Voltage				24		V
Shutdown Pin Current	$V_{SHDN} = 5\text{V}$	●	5	10	20	μA
	$V_{SHDN} \leq V_{THRESHOLD} (\cong 2.5\text{V})$	●			50	μA
Shutdown Thresholds	Switch Duty Cycle = 0	●	2.2	2.45	2.7	V
	Fully Shutdown	●	0.1	0.30	0.5	V
Status Window	As a Percent of Output Voltage		± 4	± 5	± 6	%
Status High Level	$I_{STATUS} = 10\mu\text{A}$ Sourcing	●	3.5	4.5	5.0	V

ELECTRICAL CHARACTERISTICS

The ● denotes the specifications which apply over the full operating temperature range, otherwise specifications are at $T_A = 25^\circ\text{C}$, $T_J = 25^\circ\text{C}$, $V_{IN} = 25\text{V}$, unless otherwise noted.

PARAMETER	CONDITIONS	MIN	TYP	MAX	UNITS
Status Low Level	$I_{STATUS} = 1.6\text{mA}$ Sinking ●		0.25	0.4	V
Status Delay Time			9		μs
Status Minimum Width			30		μs

Note 1: Stresses beyond those listed under Absolute Maximum Ratings may cause permanent damage to the device. Exposure to any Absolute Maximum Rating condition for extended periods may affect device reliability and lifetime.

Note 2: To calculate maximum switch ON voltage at current between low and high conditions, a linear interpolation may be used.

Note 3: A feedback pin voltage (V_{FB}) of 2.5V forces the V_C pin to its low clamp level and the switch duty cycle to zero. This approximates the zero load condition where duty cycle approaches zero. The LT1176-5 has $V_{SENSE} = 5.5\text{V}$.

Note 4: Total voltage from V_{IN} pin to ground pin must be $\geq 8\text{V}$ after start-up for proper regulation.

Note 5: Switch frequency is internally scaled down when the feedback pin voltage is less than 1.3V to avoid extremely short switch-on times. During testing, V_{FB} or V_{SENSE} is adjusted to give a minimum switch-on time of 1 μs .

Note 6: $I_{LM} = (R_{LIM} - 1\text{k})/7.65\text{k}$

Note 7: Switch to input voltage limitation must also be observed.

Note 8: $V_{MAX} = 35\text{V}$

Note 9: Does not include switch leakage.

Note 10: Error amplifier voltage gain and transconductance are specified relative to the internal feedback node. To calculate gain and transconductance from the sense pin (Output) to the V_C pin on the LT1176-5, multiply by 0.44.

Application Hints

Although the LT1176 has a peak switch rating of 1.2A and a maximum duty cycle of 85%, it must be used cautiously in applications which require high switch current and high duty cycle simultaneously, to avoid excessive chip temperature. Thermal resistance is 90°C/W for the 8-pin DIP package and 50°C/W for the 20-pin SO. This limits continuous chip power dissipation to the 0.5W to 1W range. These numbers assume typical mounting techniques. Extra or thick copper connected to the leads can reduce thermal resistance. Bonding the package to the board or using a clip style heat sink can also help. The following formulas will give chip power dissipation and peak switch current for the standard buck converter. Note that surges less than 30 seconds do not need to be considered from a thermal standpoint, but for proper regulation, they must not result in peak switch currents exceeding the 1.2A limit.

$$\text{Power} = I_{LOAD}(V_{OUT}/V_{IN}) + V_{IN} [7\text{mA} + 3\text{mA} (V_{OUT}/V_{IN}) + 0.012 (I_{LOAD})]$$

$$I_{PEAK} = I_{LOAD(PEAK)} + [V_{OUT}(V_{IN} - V_{OUT})]/2E^5(V_{IN})(L)$$

Example: $V_{IN} = 15\text{V}$, $V_{OUT} = 5\text{V}$, $I_{LOAD} = 0.5\text{A}$ Continuous, 0.8A Peak, $L = 100\mu\text{H}$

$$\text{Power} (I_{LOAD} = 0.5\text{A}) = 0.38\text{W}$$

$$I_{PEAK} (I_{LOAD} = 0.8\text{A}) = 0.97\text{A}$$

Where component size or height is critical, we suggest using solid tantalum capacitors (singly or in parallel), but be sure to use units rated for switching applications. Coiltronics is a good source for low profile surface mount inductors and AVX makes high quality surface mount tantalum capacitors. For further help, use Application Notes 19 and 44, LTC's SwitcherCAD® computer design program, and our knowledgeable application department.

BLOCK DIAGRAM

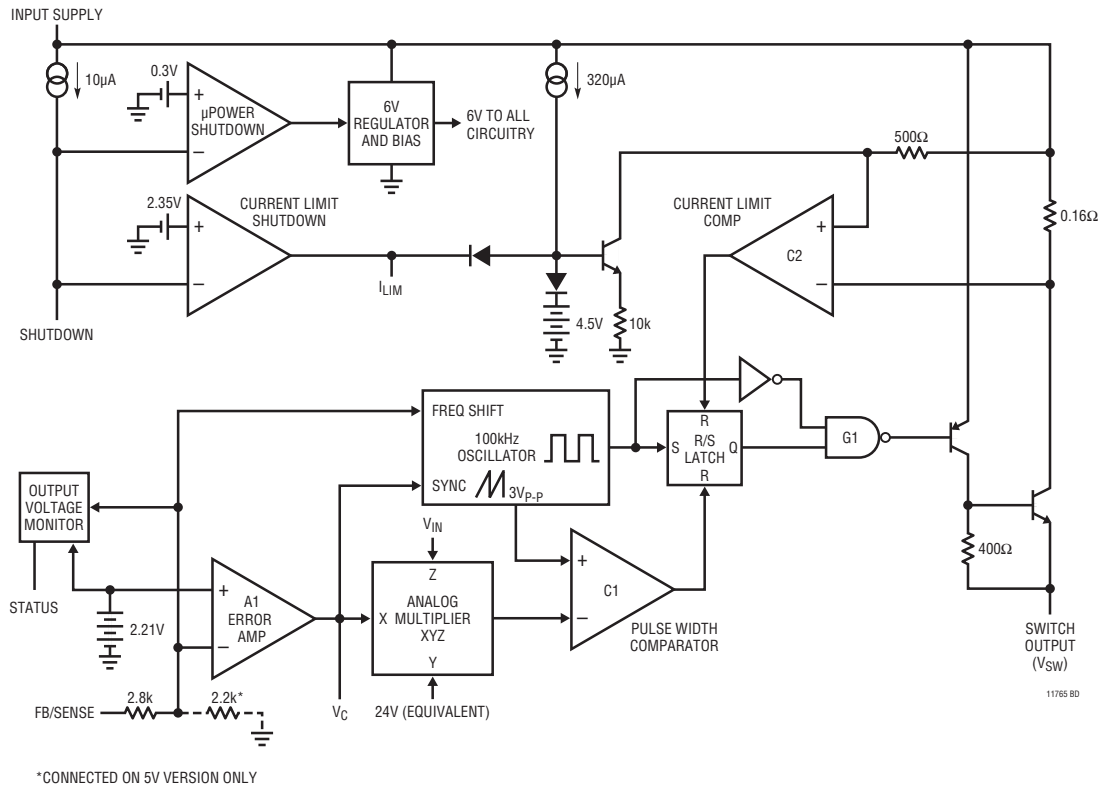

PACKAGE DESCRIPTION

N8 Package
8-Lead PDIP (Narrow .300 Inch)
 (Reference LTC DWG # 05-08-1510)

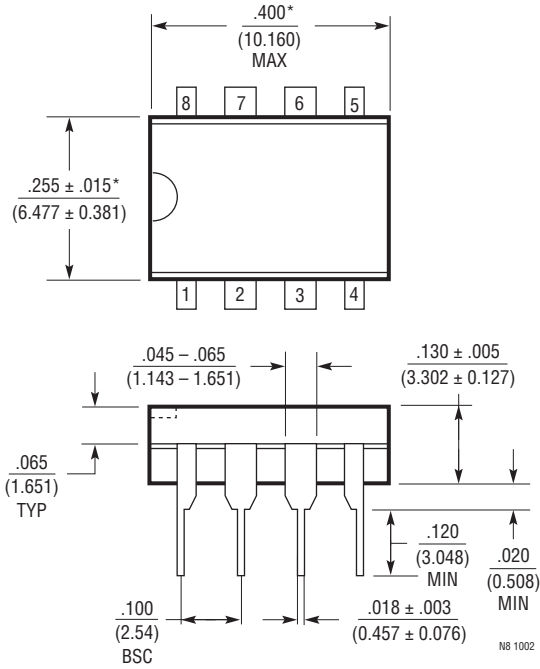

NOTE:
 1. DIMENSIONS ARE $\frac{\text{INCHES}}{\text{MILLIMETERS}}$
 *THESE DIMENSIONS DO NOT INCLUDE MOLD FLASH OR PROTRUSIONS.
 MOLD FLASH OR PROTRUSIONS SHALL NOT EXCEED .010 INCH (0.254mm)

N8 1002

REVISION HISTORY

REV	DATE	DESCRIPTION	PAGE NUMBER
A	01/11	Corrected Typical Application	1
		Updated part markings in Order Information	2
		Revised Electrical Characteristics	3
		Updated Package Description	8
B	2/11	Revised Shutdown Pin Current in Electrical Characteristics	3

PACKAGE DESCRIPTION

SW Package 20-Lead Plastic Small Outline (Wide .300 Inch) (Reference LTC DWG # 05-08-1620)

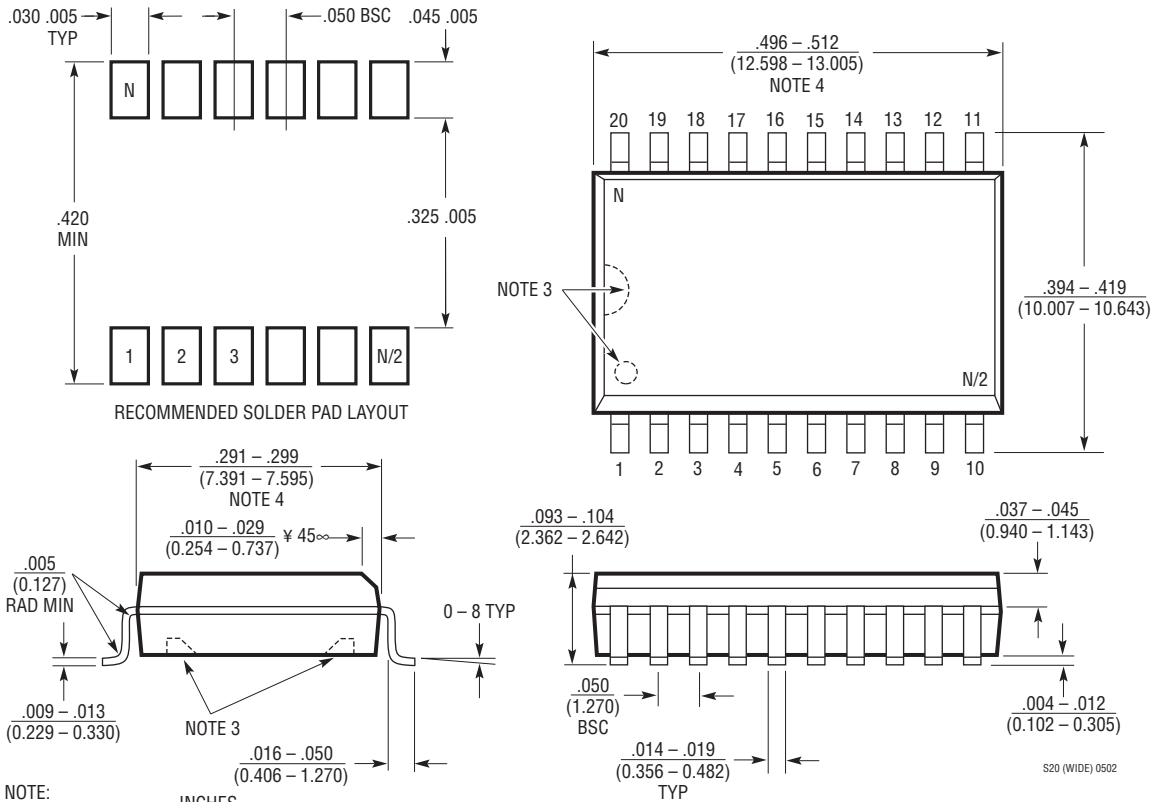

- NOTE:
1. DIMENSIONS IN $\frac{\text{INCHES}}{\text{MILLIMETERS}}$
 2. DRAWING NOT TO SCALE
 3. PIN 1 IDENT. NOTCH ON TOP AND CAVITIES ON THE BOTTOM OF PACKAGES ARE THE MANUFACTURING OPTIONS. THE PART MAY BE SUPPLIED WITH OR WITHOUT ANY OF THE OPTIONS
 4. THESE DIMENSIONS DO NOT INCLUDE MOLD FLASH OR PROTRUSIONS. MOLD FLASH OR PROTRUSIONS SHALL NOT EXCEED $.006''$ (0.15mm)

S20 (WIDE) 0502

Looking for pricing, stock, or lifecycle information?

Click below to explore more details on WIN SOURCE:

 [View LT1176CN8-5 on WIN SOURCE](#)

 [Linear Technology](#) Information

Optimize Your Supply Chain with WIN SOURCE Solutions

-  Global Sourcing Solution
-  Obsolete Management
-  Cost Control Management
-  Shortage Management
-  Alternative Solution
-  Excess Inventory Management