



**THE DATASHEET OF
LT1207CS#PBF**



FEATURES

- 250mA Minimum Output Drive Current
- 60MHz Bandwidth, $A_V = 2$, $R_L = 100\Omega$
- 900V/ μ s Slew Rate, $A_V = 2$, $R_L = 50\Omega$
- 0.02% Differential Gain, $A_V = 2$, $R_L = 30\Omega$
- 0.17° Differential Phase, $A_V = 2$, $R_L = 30\Omega$
- High Input Impedance: 10M Ω
- Shutdown Mode: $I_S < 200\mu$ A per Amplifier
- Stable with $C_L = 10,000$ pF

APPLICATIONS

- ADSL/HDSL Drivers
- Video Amplifiers
- Cable Drivers
- RGB Amplifiers
- Test Equipment Amplifiers
- Buffers

DESCRIPTION

The LT[®]1207 is a dual version of the LT1206 high speed current feedback amplifier. Like the LT1206, each CFA in the dual has excellent video characteristics: 60MHz bandwidth, 250mA minimum output drive current, 400V/ μ s minimum slew rate, low differential gain (0.02% typ) and low differential phase (0.17° typ). The LT1207 includes a pin for an optional compensation network which stabilizes the amplifier for heavy capacitive loads. Both amplifiers have thermal and current limit circuits which protect against fault conditions. These capabilities make the LT1207 well suited for driving difficult loads such as cables in video or digital communication systems.

Operation is fully specified from ± 5 V to ± 15 V supplies. Supply current is typically 20mA per amplifier. Two micropower shutdown controls place each amplifier in a high impedance low current mode, dropping supply current to 200 μ A per amplifier. For reduced bandwidth applications, supply current can be lowered by adding a resistor in series with the Shutdown pin.

The LT1207 is manufactured on Linear Technology's complementary bipolar process and is available in a low thermal resistance 16-lead SO package.

 LTC and LT are registered trademarks of Linear Technology Corporation.

TYPICAL APPLICATION

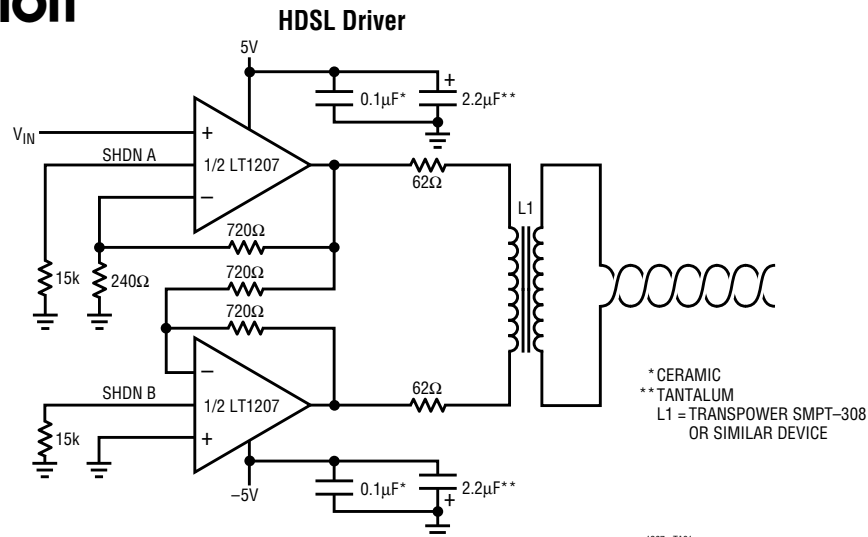

ABSOLUTE MAXIMUM RATINGS

Supply Voltage ±18V
 Input Current per Amplifier ±15mA
 Output Short-Circuit Duration (Note 1) Continuous
 Specified Temperature Range (Note 2) 0°C to 70°C
 Operating Temperature Range -40°C to 85°C
 Junction Temperature 150°C
 Storage Temperature Range -65°C to 150°C
 Lead Temperature (Soldering, 10 sec) 300°C

PACKAGE/ORDER INFORMATION

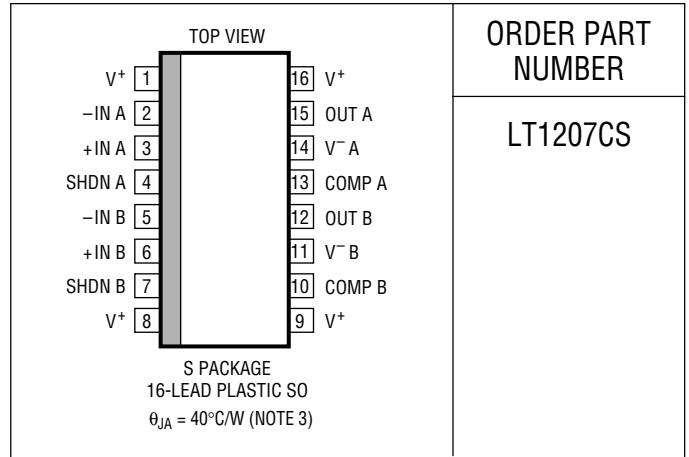

ORDER PART NUMBER

LT1207CS

Consult factory for Industrial and Military grade parts.

ELECTRICAL CHARACTERISTICS

$V_{CM} = 0$, $\pm 5V \leq V_S \leq \pm 15V$, pulse tested, $V_{SHDN A} = 0V$, $V_{SHDN B} = 0V$, unless otherwise noted.

SYMBOL	PARAMETER	CONDITIONS	MIN	TYP	MAX	UNITS
V_{OS}	Input Offset Voltage	$T_A = 25^{\circ}\text{C}$		±3	±10	mV
	Input Offset Voltage Drift			10	±15	$\mu\text{V}/^{\circ}\text{C}$
I_{IN}^{+}	Noninverting Input Current	$T_A = 25^{\circ}\text{C}$		±2	±5	μA
I_{IN}^{-}	Inverting Input Current	$T_A = 25^{\circ}\text{C}$		±10	±60	μA
e_n	Input Noise Voltage Density	$f = 10\text{kHz}$, $R_F = 1\text{k}$, $R_G = 10\Omega$, $R_S = 0\Omega$		3.6		$\text{nV}/\sqrt{\text{Hz}}$
$+i_n$	Input Noise Current Density	$f = 10\text{kHz}$, $R_F = 1\text{k}$, $R_G = 10\Omega$, $R_S = 10\text{k}$		2		$\text{pA}/\sqrt{\text{Hz}}$
$-i_n$	Input Noise Current Density	$f = 10\text{kHz}$, $R_F = 1\text{k}$, $R_G = 10\Omega$, $R_S = 10\text{k}$		30		$\text{pA}/\sqrt{\text{Hz}}$
R_{IN}	Input Resistance	$V_{IN} = \pm 12V$, $V_S = \pm 15V$	●	1.5	10	$\text{M}\Omega$
		$V_{IN} = \pm 2V$, $V_S = \pm 5V$	●	0.5	5	$\text{M}\Omega$
C_{IN}	Input Capacitance	$V_S = \pm 15V$		2		pF
		Input Voltage Range	●	±12	±13.5	V
		●	±2	±3.5	V	
CMRR	Common Mode Rejection Ratio	$V_S = \pm 15V$, $V_{CM} = \pm 12V$	●	55	62	dB
		$V_S = \pm 5V$, $V_{CM} = \pm 2V$	●	50	60	dB
PSRR	Inverting Input Current Common Mode Rejection	$V_S = \pm 15V$, $V_{CM} = \pm 12V$	●	0.1	10	$\mu\text{A}/\text{V}$
		$V_S = \pm 5V$, $V_{CM} = \pm 2V$	●	0.1	10	$\mu\text{A}/\text{V}$
PSRR	Power Supply Rejection Ratio	$V_S = \pm 5V$ to $\pm 15V$	●	60	77	dB

ELECTRICAL CHARACTERISTICS

$V_{CM} = 0$, $\pm 5V \leq V_S \leq \pm 15V$, pulse tested, $V_{SHDN A} = 0V$, $V_{SHDN B} = 0V$, unless otherwise noted.

SYMBOL	PARAMETER	CONDITIONS	MIN	TYP	MAX	UNITS	
	Noninverting Input Current Power Supply Rejection	$V_S = \pm 5V$ to $\pm 15V$	●	30	500	nA/V	
	Inverting Input Current Power Supply Rejection	$V_S = \pm 5V$ to $\pm 15V$	●	0.7	5	$\mu A/V$	
A_V	Large-Signal Voltage Gain	$V_S = \pm 15V$, $V_{OUT} = \pm 10V$, $R_L = 50\Omega$ $V_S = \pm 5V$, $V_{OUT} = \pm 2V$, $R_L = 25\Omega$	● ●	55 71 68		dB dB	
R_{OL}	Transresistance, $\Delta V_{OUT}/\Delta I_{IN}^-$	$V_S = \pm 15V$, $V_{OUT} = \pm 10V$, $R_L = 50\Omega$ $V_S = \pm 5V$, $V_{OUT} = \pm 2V$, $R_L = 25\Omega$	● ●	100 260 75 200		k Ω k Ω	
V_{OUT}	Maximum Output Voltage Swing	$V_S = \pm 15V$, $R_L = 50\Omega$, $T_A = 25^\circ C$ $V_S = \pm 5V$, $R_L = 25\Omega$, $T_A = 25^\circ C$	● ●	± 11.5 ± 10.0 ± 2.5 ± 2.0	± 12.5 ± 3.0	V V V V	
I_{OUT}	Maximum Output Current	$R_L = 1\Omega$	●	250	500	1200	mA
I_S	Supply Current per Amplifier	$V_S = \pm 15V$, $V_{SHDN} = 0V$, $T_A = 25^\circ C$	●		20	30 35	mA mA
	Supply Current per Amplifier, $R_{SHDN} = 51k$ (Note 4)	$V_S = \pm 15V$, $T_A = 25^\circ C$			12	17	mA
	Positive Supply Current per Amplifier, Shutdown	$V_S = \pm 15V$, $V_{SHDN A} = 15V$, $V_{SHDN B} = 15V$	●			200	μA
	Output Leakage Current, Shutdown	$V_S = \pm 15V$, $V_{SHDN} = 15V$, $V_{OUT} = 0V$	●			10	μA
SR	Slew Rate (Note 5)	$A_V = 2$, $T_A = 25^\circ C$		400	900		V/ μs
	Differential Gain (Note 6)	$V_S = \pm 15V$, $R_F = 560\Omega$, $R_G = 560\Omega$, $R_L = 30\Omega$			0.02		%
	Differential Phase (Note 6)	$V_S = \pm 15V$, $R_F = 560\Omega$, $R_G = 560\Omega$, $R_L = 30\Omega$			0.17		DEG
BW	Small-Signal Bandwidth	$V_S = \pm 15V$, Peaking $\leq 0.5dB$ $R_F = R_G = 620\Omega$, $R_L = 100\Omega$			60		MHz
		$V_S = \pm 15V$, Peaking $\leq 0.5dB$ $R_F = R_G = 649\Omega$, $R_L = 50\Omega$			52		MHz
		$V_S = \pm 15V$, Peaking $\leq 0.5dB$ $R_F = R_G = 698\Omega$, $R_L = 30\Omega$			43		MHz
		$V_S = \pm 15V$, Peaking $\leq 0.5dB$ $R_F = R_G = 825\Omega$, $R_L = 10\Omega$			27		MHz

The ● denotes specifications which apply for $0^\circ C \leq T_A \leq 70^\circ C$.

Note 1: Applies to short circuits to ground only. A short circuit between the output and either supply may permanently damage the part when operated on supplies greater than $\pm 10V$.

Note 2: Commercial grade parts are designed to operate over the temperature range of $-40^\circ C$ to $85^\circ C$ but are neither tested nor guaranteed beyond $0^\circ C$ to $70^\circ C$. Industrial grade parts tested over $-40^\circ C$ to $85^\circ C$ are available on special request. Consult factory.

Note 3: Thermal resistance θ_{JA} varies from $40^\circ C/W$ to $60^\circ C/W$ depending upon the amount of PC board metal attached to the device. θ_{JA} is specified for a $2500mm^2$ test board covered with 2oz copper on both sides.

Note 4: R_{SHDN} is connected between the Shutdown pin and ground.

Note 5: Slew rate is measured at $\pm 5V$ on a $\pm 10V$ output signal while operating on $\pm 15V$ supplies with $R_F = 1.5k$, $R_G = 1.5k$ and $R_L = 400\Omega$.

Note 6: NTSC composite video with an output level of 2V.

SMALL-SIGNAL BANDWIDTH

$I_S = 20\text{mA}$ per Amplifier Typical, Peaking $\leq 0.1\text{dB}$

A_V	R_L	R_F	R_G	-3dB BW (MHz)	-0.1dB BW (MHz)
$V_S = \pm 5\text{V}, R_{SHDN} = 0\Omega$					
-1	150	562	562	48	21.4
	30	649	649	34	17
	10	732	732	22	12.5
1	150	619	-	54	22.3
	30	715	-	36	17.5
	10	806	-	22.4	11.5
2	150	576	576	48	20.7
	30	649	649	35	18.1
	10	750	750	22.4	11.7
10	150	442	48.7	40	19.2
	30	511	56.2	31	16.5
	10	649	71.5	20	10.2

A_V	R_L	R_F	R_G	-3dB BW (MHz)	-0.1dB BW (MHz)
$V_S = \pm 15\text{V}, R_{SHDN} = 0\Omega$					
-1	150	681	681	50	19.2
	30	768	768	35	17
	10	887	887	24	12.3
1	150	768	-	66	22.4
	30	909	-	37	17.5
	10	1k	-	23	12
2	150	665	665	55	23
	30	787	787	36	18.5
	10	931	931	22.5	11.8
10	150	487	536	44	20.7
	30	590	64.9	33	17.5
	10	768	84.5	20.7	10.8

$I_S = 10\text{mA}$ per Amplifier Typical, Peaking $\leq 0.1\text{dB}$

A_V	R_L	R_F	R_G	-3dB BW (MHz)	-0.1dB BW (MHz)
$V_S = \pm 5\text{V}, R_{SHDN} = 10.2\text{k}$					
-1	150	576	576	35	17
	30	681	681	25	12.5
	10	750	750	16.4	8.7
1	150	665	-	37	17.5
	30	768	-	25	12.6
	10	845	-	16.5	8.2
2	150	590	590	35	16.8
	30	681	681	25	13.4
	10	768	768	16.2	8.1
10	150	301	33.2	31	15.6
	30	392	43.2	23	11.9
	10	499	54.9	15	7.8

A_V	R_L	R_F	R_G	-3dB BW (MHz)	-0.1dB BW (MHz)
$V_S = \pm 15\text{V}, R_{SHDN} = 60.4\text{k}$					
-1	150	634	634	41	19.1
	30	768	768	26.5	14
	10	866	866	17	9.4
1	150	768	-	44	18.8
	30	909	-	28	14.4
	10	1k	-	16.8	8.3
2	150	649	649	40	18.5
	30	787	787	27	14.1
	10	931	931	16.5	8.1
10	150	301	33.2	33	15.6
	30	402	44.2	25	13.3
	10	590	64.9	15.3	7.4

$I_S = 5\text{mA}$ per Amplifier Typical, Peaking $\leq 0.1\text{dB}$

A_V	R_L	R_F	R_G	-3dB BW (MHz)	-0.1dB BW (MHz)
$V_S = \pm 5\text{V}, R_{SHDN} = 22.1\text{k}$					
-1	150	604	604	21	10.5
	30	715	715	14.6	7.4
	10	681	681	10.5	6.0
1	150	768	-	20	9.6
	30	866	-	14.1	6.7
	10	825	-	9.8	5.1
2	150	634	634	20	9.6
	30	750	750	14.1	7.2
	10	732	732	9.6	5.1
10	150	100	11.1	16.2	5.8
	30	100	11.1	13.4	7.0
	10	100	11.1	9.5	4.7

A_V	R_L	R_F	R_G	-3dB BW (MHz)	-0.1dB BW (MHz)
$V_S = \pm 15\text{V}, R_{SHDN} = 121\text{k}$					
-1	150	619	619	25	12.5
	30	787	787	15.8	8.5
	10	825	825	10.5	5.4
1	150	845	-	23	10.6
	30	1k	-	15.3	7.6
	10	1k	-	10	5.2
2	150	681	681	23	10.2
	30	845	845	15	7.7
	10	866	866	10	5.4
10	150	100	11.1	15.9	4.5
	30	100	11.1	13.6	6
	10	100	11.1	9.6	4.5

TYPICAL PERFORMANCE CHARACTERISTICS

Bandwidth vs Supply Voltage

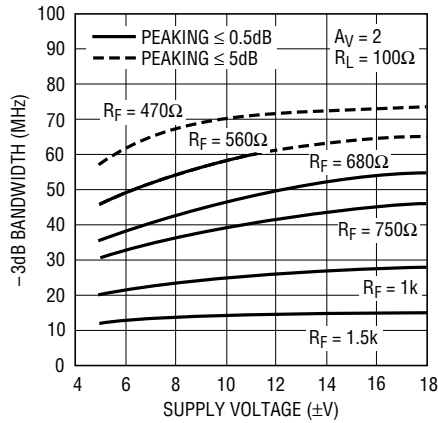

LT1207 • TPC01

Bandwidth vs Supply Voltage

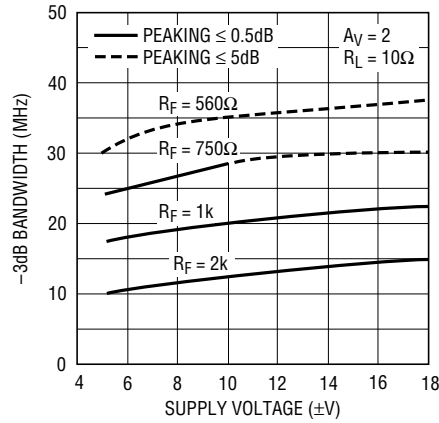

LT1207 • TPC02

Bandwidth and Feedback Resistance vs Capacitive Load for 0.5dB Peak

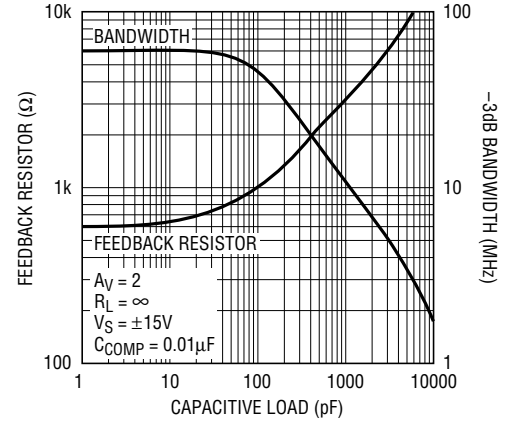

LT1207 • TPC03

Bandwidth vs Supply Voltage

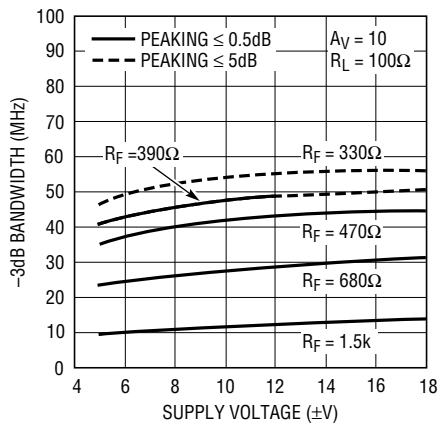

LT1207 • TPC04

Bandwidth vs Supply Voltage

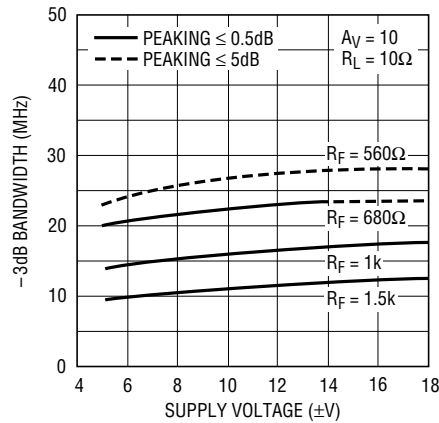

LT1207 • TPC05

Bandwidth and Feedback Resistance vs Capacitive Load for 5dB Peak

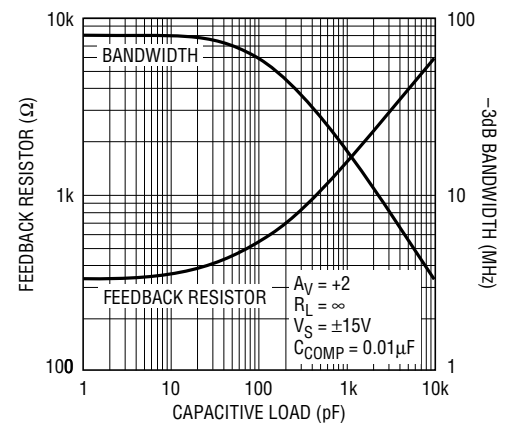

LT1207 • TPC06

Differential Phase vs Supply Voltage

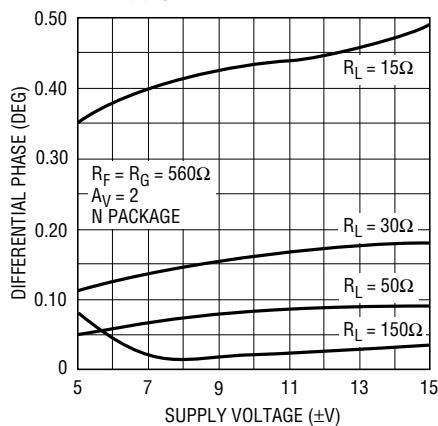

LT1207 • TPC07

Differential Gain vs Supply Voltage

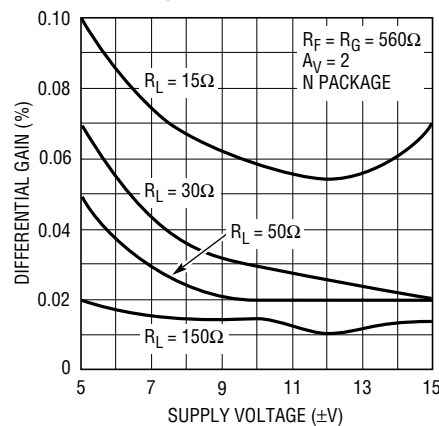

LT1207 • TPC08

Spot Noise Voltage and Current vs Frequency

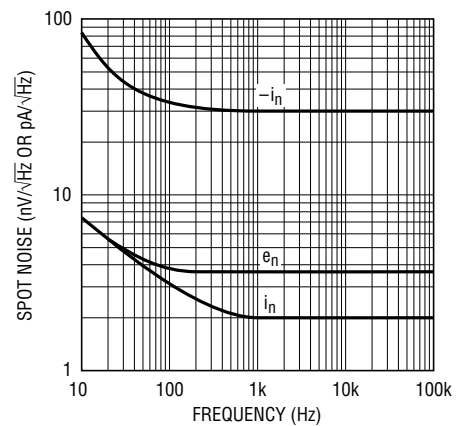

LT1207 • TPC09

TYPICAL PERFORMANCE CHARACTERISTICS

Supply Current vs Supply Voltage

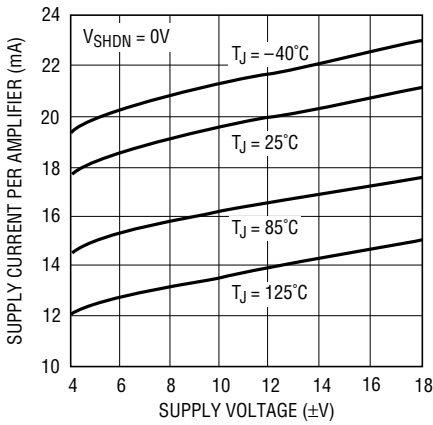

LT1207 • TPC10

Supply Current vs Ambient Temperature, $V_S = \pm 5V$

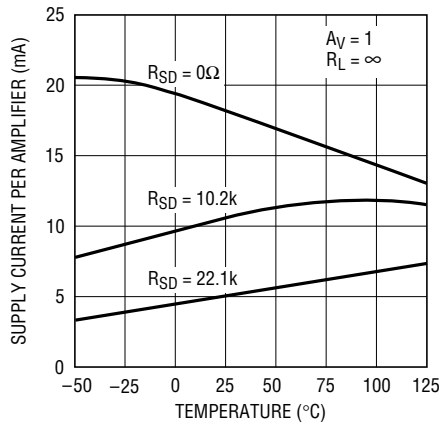

LT1207 • TPC11

Supply Current vs Ambient Temperature, $V_S = \pm 15V$

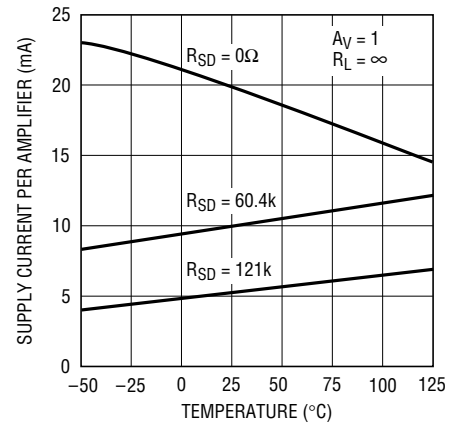

LT1207 • TPC12

Supply Current vs Shutdown Pin Current

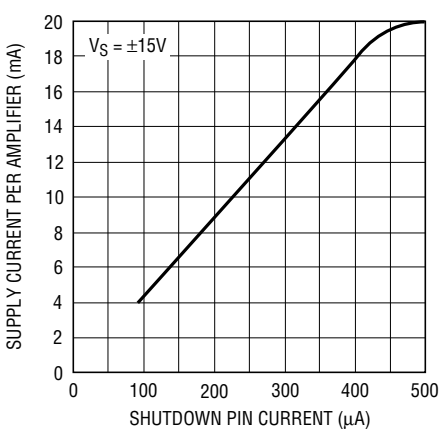

LT1207 • TPC13

Input Common Mode Limit vs Junction Temperature

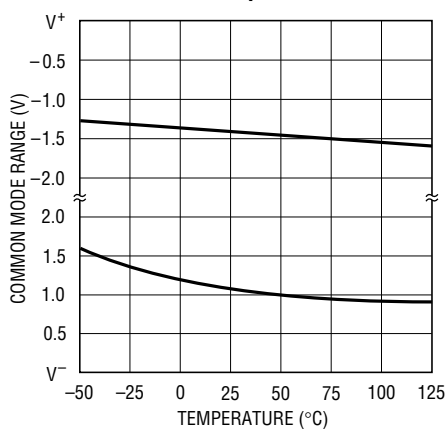

LT1207 • TPC14

Output Short-Circuit Current vs Junction Temperature

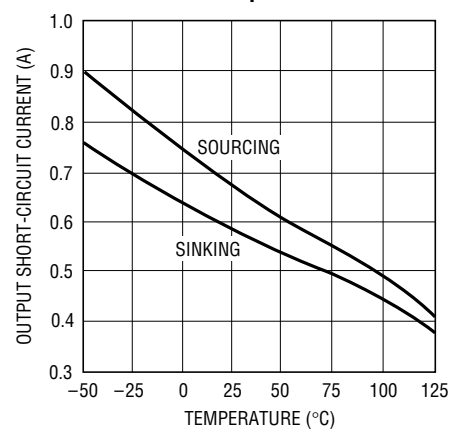

LT1207 • TPC15

Output Saturation Voltage vs Junction Temperature

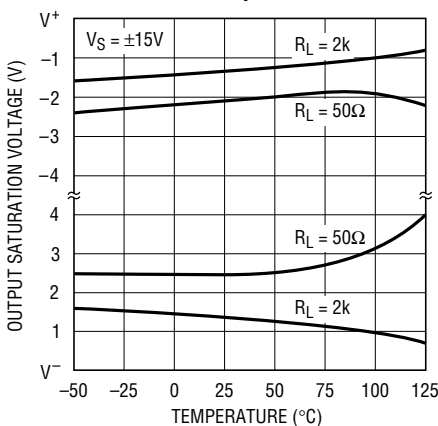

LT1207 • TPC16

Power Supply Rejection Ratio vs Frequency

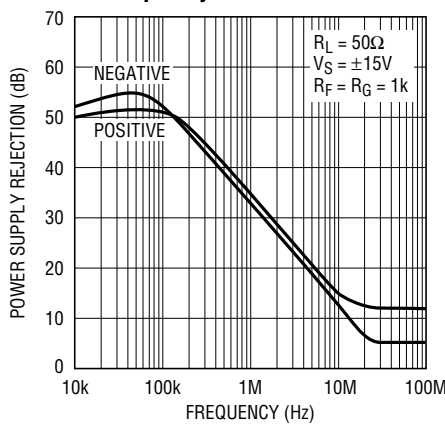

LT1207 • TPC17

Supply Current vs Large-Signal Output Frequency (No Load)

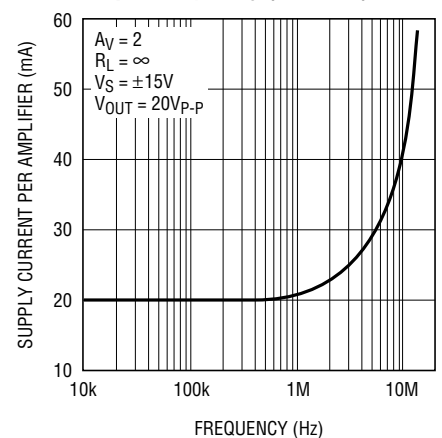

LT1207 • TPC18

TYPICAL PERFORMANCE CHARACTERISTICS

Output Impedance vs Frequency

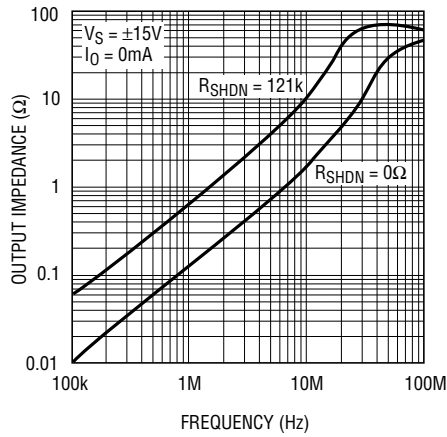

LT1207 • TPC19

Output Impedance in Shutdown vs Frequency

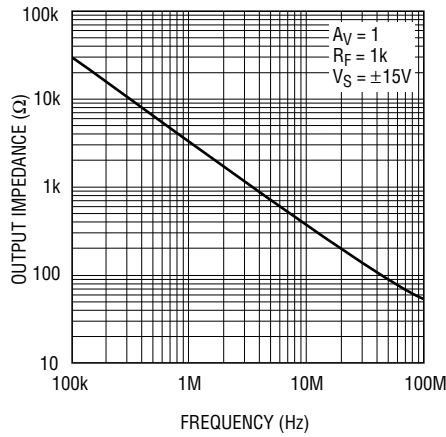

LT1207 • TPC20

2nd and 3rd Harmonic Distortion vs Frequency

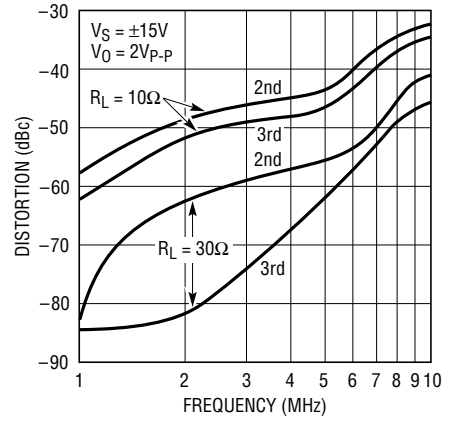

LT1207 • TPC21

3rd Order Intercept vs Frequency

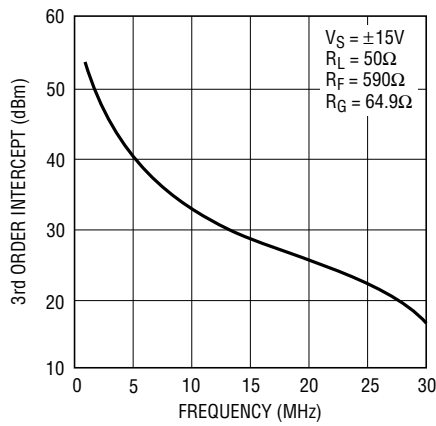

LT1207 • TPC22

Test Circuit for 3rd Order Intercept

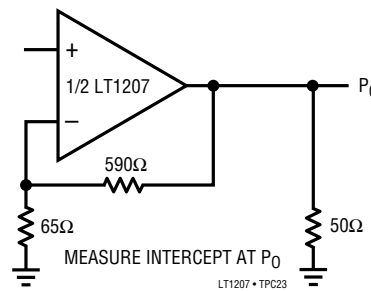

LT1207 • TPC23

SIMPLIFIED SCHEMATIC

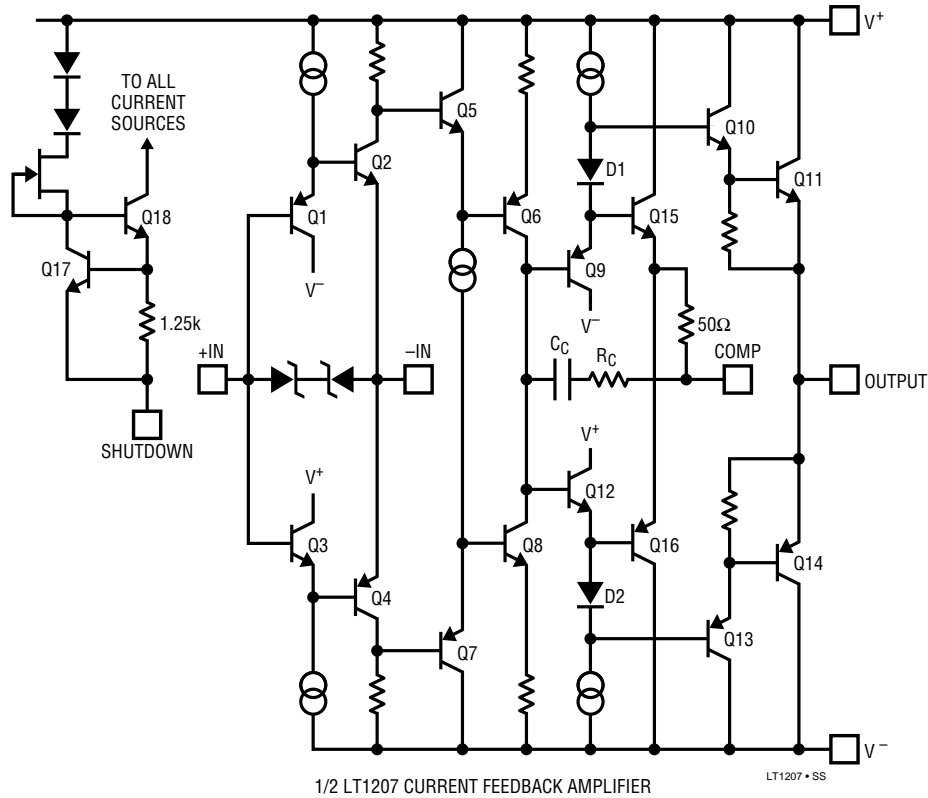

APPLICATIONS INFORMATION

The LT1207 is a dual current feedback amplifier with high output current drive capability. The device is stable with large capacitive loads and can easily supply the high currents required by capacitive loads. The amplifier will drive low impedance loads such as cables with excellent linearity at high frequencies.

Feedback Resistor Selection

The optimum value for the feedback resistors is a function of the operating conditions of the device, the load impedance and the desired flatness of response. The Typical AC Performance tables give the values which result in the highest 0.1dB and 0.5dB bandwidths for various resistive loads and operating conditions. If this level of flatness is not required, a higher bandwidth can be obtained by use of a lower feedback resistor. The characteristic curves of Bandwidth vs Supply Voltage indicate feedback resistors for peaking up to 5dB. These curves use a solid line when the response has less than 0.5dB of peaking and a dashed

line when the response has 0.5dB to 5dB of peaking. The curves stop where the response has more than 5dB of peaking.

For resistive loads, the COMP pin should be left open (see section on capacitive loads).

Capacitive Loads

Each amplifier in the LT1207 includes an optional compensation network for driving capacitive loads. This network eliminates most of the output stage peaking associated with capacitive loads, allowing the frequency response to be flattened. Figure 1 shows the effect of the network on a 200pF load. Without the optional compensation, there is a 5dB peak at 40MHz caused by the effect of the capacitance on the output stage. Adding a 0.01μF bypass capacitor between the output and the COMP pins connects the compensation and completely eliminates the peaking. A lower value feedback resistor can now be used, resulting in a response which is flat to 0.35dB to 30MHz.

APPLICATIONS INFORMATION

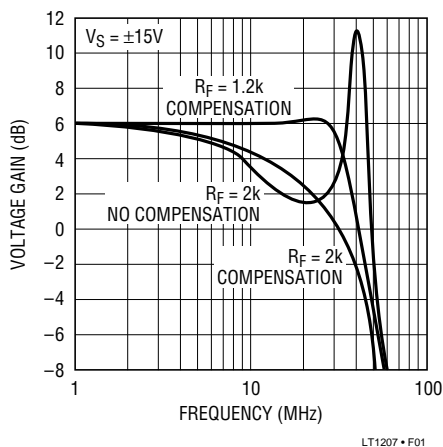

Figure 1.

The network has the greatest effect for C_L in the range of 0pF to 1000pF. The graph of Maximum Capacitive Load vs Feedback Resistor can be used to select the appropriate value of the feedback resistor. The values shown are for 0.5dB and 5dB peaking at a gain of 2 with no resistive load. This is a worst-case condition, as the amplifier is more stable at higher gains and with some resistive load in parallel with the capacitance. Also shown is the -3 dB bandwidth with the suggested feedback resistor vs the load capacitance.

Although the optional compensation works well with capacitive loads, it simply reduces the bandwidth when it is connected with resistive loads. For instance, with a 30 Ω load, the bandwidth drops from 55MHz to 35MHz when the compensation is connected. Hence, the compensation was made optional. To disconnect the optional compensation, leave the COMP pin open.

Shutdown/Current Set

If the shutdown feature is not used, the Shutdown pins must be connected to ground or V^- .

Each amplifier has a separate Shutdown pin which can be used to either turn off the amplifier, which reduces the amplifier supply current to less than 200 μ A, or to control the supply current in normal operation.

The supply current in each amplifier is controlled by the current flowing out of the Shutdown pin. When the Shutdown pin is open or driven to the positive supply, the amplifier is shut down. In the shutdown mode, the output looks like a 40pF capacitor and the supply current is

typically 100 μ A. Each Shutdown pin is referenced to the positive supply through an internal bias circuit (see the Simplified Schematic). An easy way to force shutdown is to use open drain (collector) logic. The circuit shown in Figure 2 uses a 74C904 buffer to interface between 5V logic and the LT1207. The switching time between the active and shutdown states is less than 1 μ s. A 24k pull-up resistor speeds up the turn-off time and insures that the amplifier is completely turned off. Because the pin is referenced to the positive supply, the logic used should have a breakdown voltage of greater than the positive supply voltage. No other circuitry is necessary as the internal circuit limits the Shutdown pin current to about 500 μ A. Figure 3 shows the resulting waveforms.

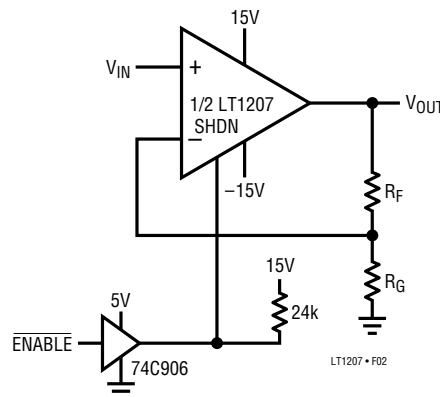

Figure 2. Shutdown Interface

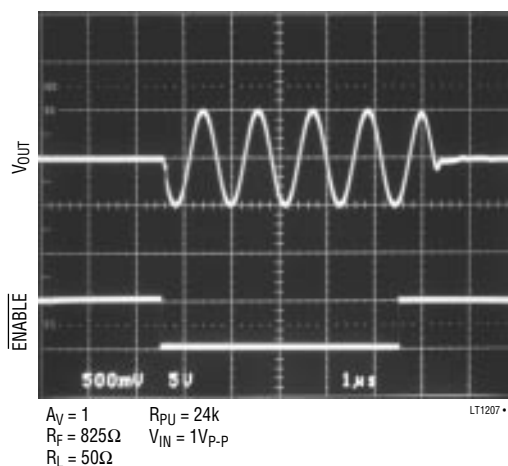

Figure 3. Shutdown Operation

For applications where the full bandwidth of the amplifier is not required, the quiescent current may be reduced by connecting a resistor from the Shutdown pin to ground.

APPLICATIONS INFORMATION

The amplifier's supply current will be approximately 40 times the current in the Shutdown pin. The voltage across the resistor in this condition is $V^+ - 3V_{BE}$. For example, a 60k resistor will set the amplifier's supply current to 10mA with $V_S = \pm 15V$.

The photos (Figures 4a and 4b) show the effect of reducing the quiescent supply current on the large-signal response. The quiescent current can be reduced to 5mA in the inverting configuration without much change in response. In noninverting mode, however, the slew rate is reduced as the quiescent current is reduced.

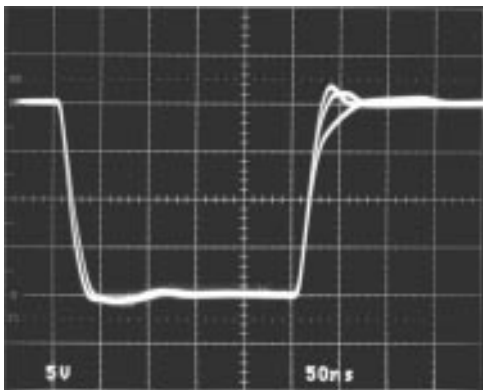

$R_F = 750\Omega$ $I_Q = 5mA, 10mA, 20mA$ $R_L = 50\Omega$ $V_S = \pm 15V$ LT1207 • F04a

Figure 4a. Large-Signal Response vs I_Q , $A_V = -1$

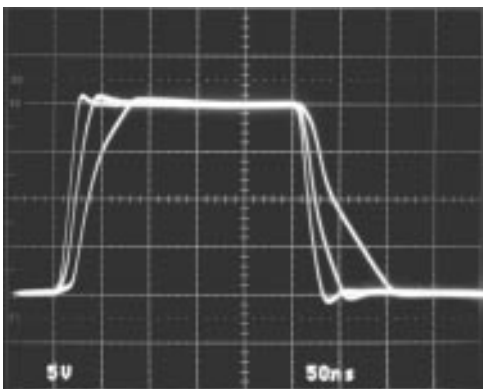

$R_F = 750\Omega$ $I_Q = 5mA, 10mA, 20mA$ $R_L = 50\Omega$ $V_S = \pm 15V$ LT1207 • F04b

Figure 4b. Large-Signal Response vs I_Q , $A_V = 2$

Slew Rate

Unlike a traditional op amp, the slew rate of a current feedback amplifier is not independent of the amplifier gain configuration. There are slew rate limitations in both the input stage and the output stage. In the inverting mode,

and for higher gains in the noninverting mode, the signal amplitude on the input pins is small and the overall slew rate is that of the output stage. The input stage slew rate is related to the quiescent current and will be reduced as the supply current is reduced. The output slew rate is set by the value of the feedback resistors and the internal capacitance. Larger feedback resistors will reduce the slew rate as will lower supply voltages, similar to the way the bandwidth is reduced. The photos (Figures 5a, 5b and 5c) show the large-signal response of the LT1207 or various gain configurations. The slew rate varies from 860V/ μs for a gain of 1, to 1400V/ μs for a gain of -1 .

When the LT1207 is used to drive capacitive loads, the available output current can limit the overall slew rate. In the fastest configuration, the LT1207 is capable of a slew rate of over 1V/ns. The current required to slew a capacitor

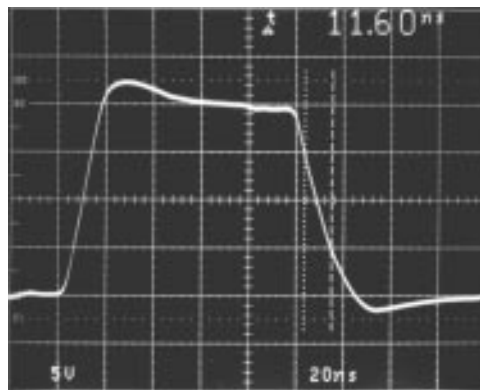

$R_F = 825\Omega$ $V_S = \pm 15V$ $R_L = 50\Omega$ LT1207 • F05a

Figure 5a. Large-Signal Response, $A_V = 1$

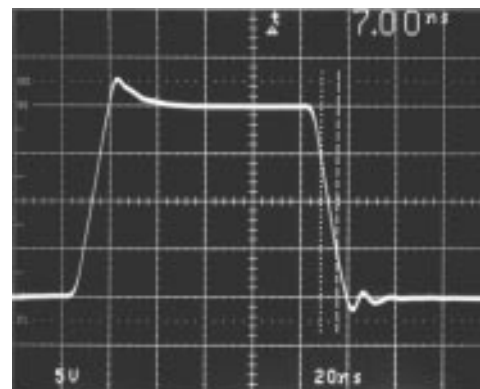

$R_F = R_G = 750\Omega$ $V_S = \pm 15V$ $R_L = 50\Omega$ LT1207 • F05b

Figure 5b. Large-Signal Response, $A_V = -1$

APPLICATIONS INFORMATION

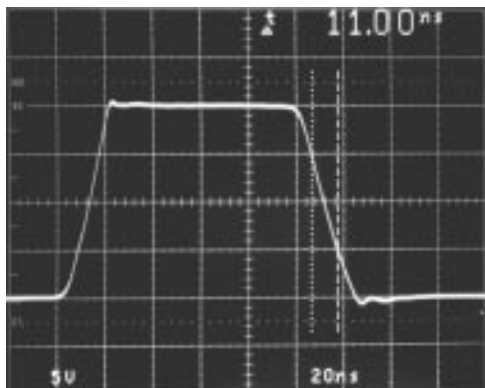

$R_F = 750\Omega$
 $R_L = 50\Omega$ LT1207 • F05c

Figure 5c. Large-Signal Response, $A_V = 2$

at this rate is 1mA per picofarad of capacitance, so 10,000pF would require 10A! The photo (Figure 6) shows the large-signal behavior with $C_L = 10,000\text{pF}$. The slew rate is about 60V/ μs , determined by the current limit of 600mA.

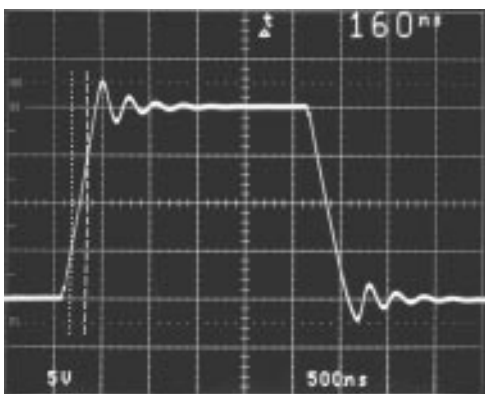

$V_S = \pm 15\text{V}$ $R_L = \infty$
 $R_F = R_G = 3\text{k}$ LT1207 • F06

Figure 6. Large-Signal Response, $C_L = 10,000\text{pF}$

Differential Input Signal Swing

The differential input swing is limited to about $\pm 6\text{V}$ by an ESD protection device connected between the inputs. In normal operation, the differential voltage between the input pins is small, so this clamp has no effect; however, in the shutdown mode the differential swing can be the same as the input swing. The clamp voltage will then set the maximum allowable input voltage. To allow for some margin, it is recommended that the input signal be less than $\pm 5\text{V}$ when the device is shut down.

Capacitance on the Inverting Input

Current feedback amplifiers require resistive feedback from the output to the inverting input for stable operation. Take care to minimize the stray capacitance between the output and the inverting input. Capacitance on the inverting input to ground will cause peaking in the frequency response (and overshoot in the transient response), but it does not degrade the stability of the amplifier.

Power Supplies

The LT1207 will operate from single or split supplies from $\pm 5\text{V}$ (10V total) to $\pm 15\text{V}$ (30V total). It is not necessary to use equal value split supplies, however the offset voltage and inverting input bias current will change. The offset voltage changes about 500 μV per volt of supply mismatch. The inverting bias current can change as much as 5 μA per volt of supply mismatch, though typically the change is less than 0.5 μA per volt.

Thermal Considerations

Each amplifier in the LT1207 includes a separate thermal shutdown circuit which protects against excessive internal (junction) temperature. If the junction temperature exceeds the protection threshold, the amplifier will begin cycling between normal operation and an off state. The cycling is not harmful to the part. The thermal cycling occurs at a slow rate, typically 10ms to several seconds, which depends on the power dissipation and the thermal time constants of the package and heat sinking. Raising the ambient temperature until the device begins thermal shutdown gives a good indication of how much margin there is in the thermal design.

Heat flows away from the amplifier through the package's copper lead frame. Heat sinking is accomplished by using the heat spreading capabilities of the PC board and its copper traces. Experiments have shown that the heat spreading copper layer does not need to be electrically connected to the tab of the device. The PCB material can be very effective at transmitting heat between the pad area attached to the tab of the device and a ground or power plane layer either inside or on the opposite side of the board. Although the actual thermal resistance of the PCB material is high, the length/area ratio of the thermal

APPLICATIONS INFORMATION

resistance between the layer is small. Copper board stiffeners and plated through holes can also be used to spread the heat generated by the device.

Table 1 lists thermal resistance for several different board sizes and copper areas. All measurements were taken in still air on 3/32" FR-4 board with 2oz copper. This data can be used as a rough guideline in estimating thermal resistance. The thermal resistance for each application will be affected by thermal interactions with other components as well as board size and shape.

Table 1. Fused 16-Lead SO Package

COPPER AREA (2oz)		TOTAL COPPER AREA	THERMAL RESISTANCE (JUNCTION-TO-AMBIENT)
TOPSIDE	BACKSIDE		
2500 sq. mm	2500 sq. mm	5000 sq. mm	40°C/W
1000 sq. mm	2500 sq. mm	3500 sq. mm	46°C/W
600 sq. mm	2500 sq. mm	3100 sq. mm	48°C/W
180 sq. mm	2500 sq. mm	2680 sq. mm	49°C/W
180 sq. mm	1000 sq. mm	1180 sq. mm	56°C/W
180 sq. mm	600 sq. mm	780 sq. mm	58°C/W
180 sq. mm	300 sq. mm	480 sq. mm	59°C/W
180 sq. mm	100 sq. mm	280 sq. mm	60°C/W
180 sq. mm	0 sq. mm	180 sq. mm	61°C/W

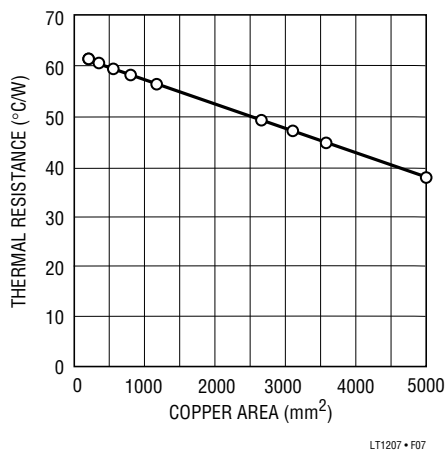

Figure 7. Thermal Resistance vs Total Copper Area (Top + Bottom)

Calculating Junction Temperature

The junction temperature can be calculated from the equation:

$$T_J = (P_D)(\theta_{JA}) + T_A$$

where:

T_J = Junction Temperature

T_A = Ambient Temperature

P_D = Device Dissipation

θ_{JA} = Thermal Resistance (Junction-to-Ambient)

As an example, calculate the junction temperature for the circuit in Figure 8 assuming a 70°C ambient temperature.

The device dissipation can be found by measuring the supply currents, calculating the total dissipation and then subtracting the dissipation in the load and feedback network.

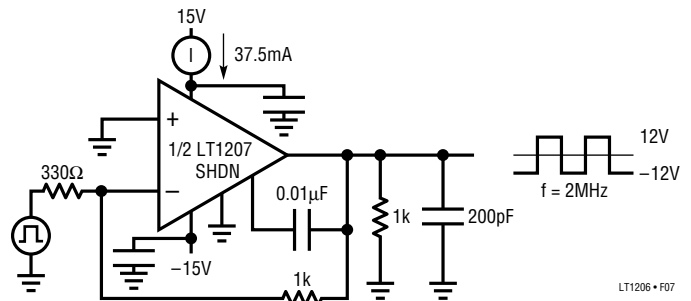

Figure 8. Thermal Calculation Example

The dissipation for each amplifier is:

$$P_D = (37.5\text{mA})(30\text{V}) - (12\text{V})^2 / (1\text{k}\Omega \parallel 1\text{k}\Omega) = 0.837\text{W}$$

The total dissipation is $P_D = 1.674\text{W}$. When a 2500 sq mm PC board with 2oz copper on top and bottom is used, the thermal resistance is 40°C/W. The junction temperature T_J is:

$$T_J = (1.674\text{W})(40^\circ\text{C/W}) + 70^\circ\text{C} = 137^\circ\text{C}$$

The maximum junction temperature for the LT1207 is 150°C, so the heat sinking capability of the board is adequate for the application.

If the copper area on the PC board is reduced to 280mm² the thermal resistance increases to 60°C/W and the junction temperature becomes:

$$T_J = (1.674\text{W})(60^\circ\text{C/W}) + 70^\circ\text{C} = 170^\circ\text{C}$$

Which is above the maximum junction temperature indicating that the heat sinking capability of the board is inadequate and should be increased.

TYPICAL APPLICATIONS

Gain of Eleven High Current Amplifier

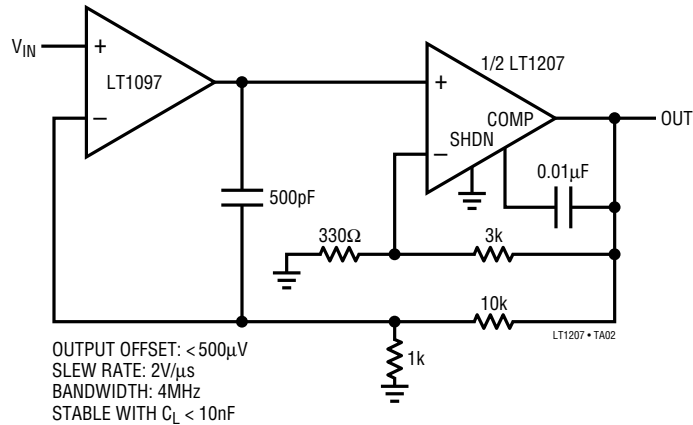

Gain of Ten Buffered Line Driver

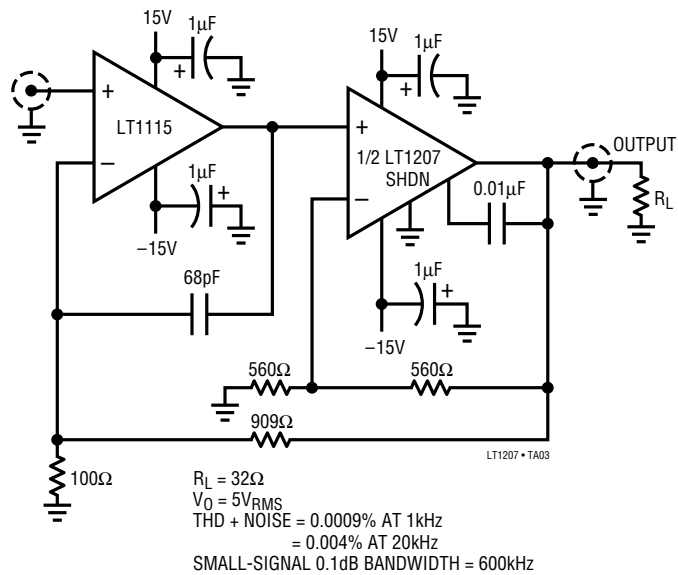

TYPICAL APPLICATIONS

CMOS Logic to Shutdown Interface

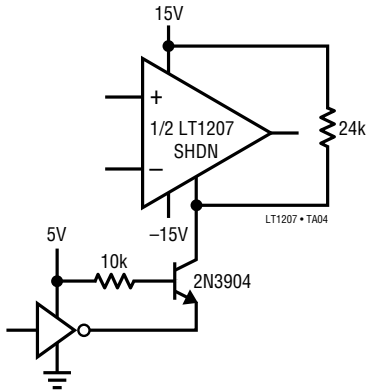

Distribution Amplifier

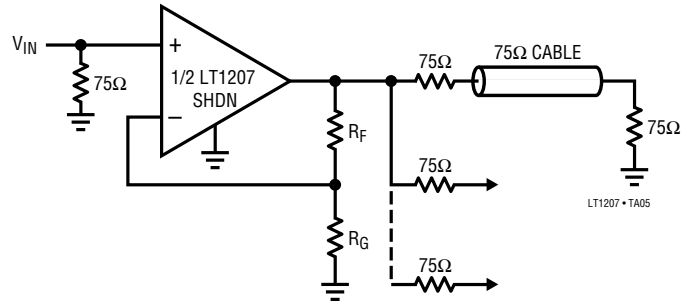

Buffer $A_V = 1$

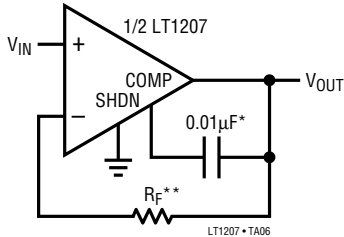

*OPTIONAL, USE WITH CAPACITIVE LOADS
 **VALUE OF R_F DEPENDS ON SUPPLY VOLTAGE AND LOADING. SELECT FROM TYPICAL AC PERFORMANCE TABLE OR DETERMINE EMPIRICALLY

Differential Output Driver

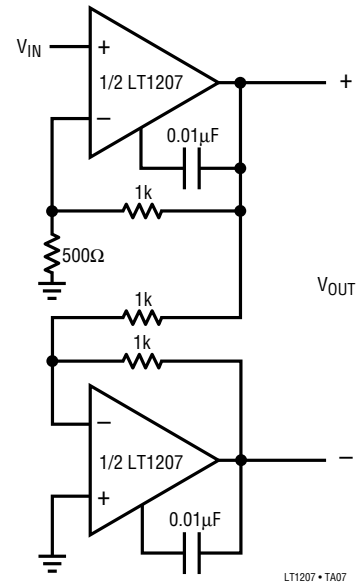

Differential Input—Differential Output Power Amplifier ($A_V = 4$)

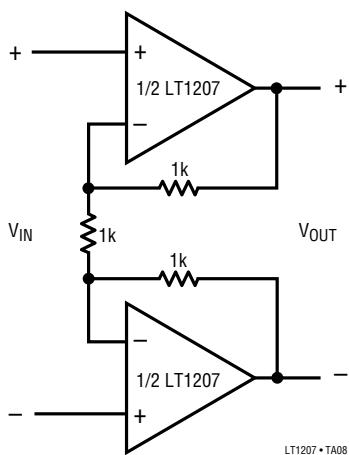

TYPICAL APPLICATIONS

Paralleling Both CFAs for Guaranteed 500mA Output Drive Current

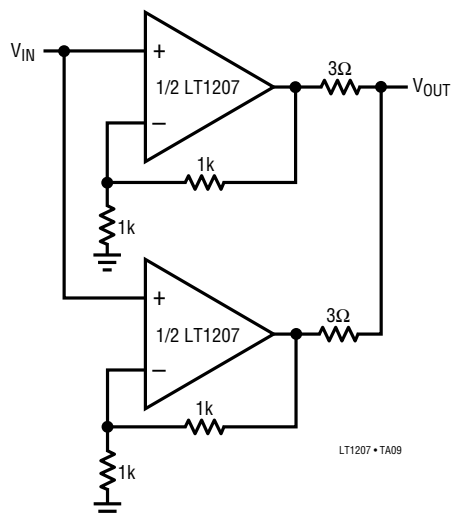

PACKAGE DESCRIPTION Dimensions in inches (millimeters) unless otherwise noted.

S Package
16-Lead Plastic Small Outline (Narrow 0.150)
 (LTC DWG # 05-08-1610)

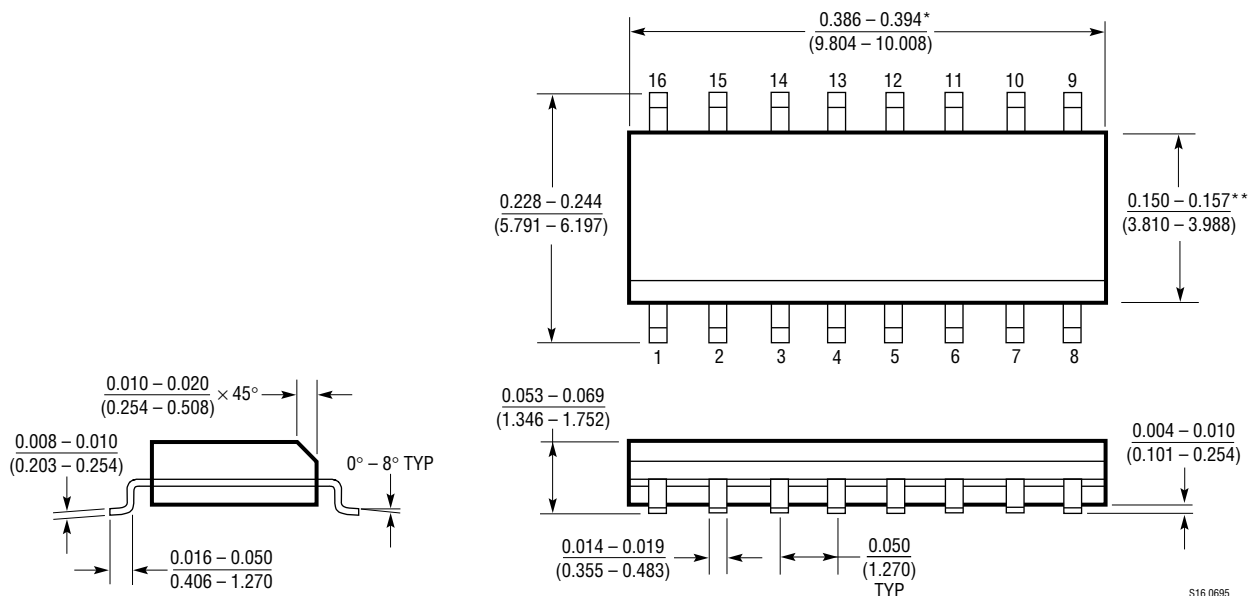

* DIMENSION DOES NOT INCLUDE MOLD FLASH. MOLD FLASH SHALL NOT EXCEED 0.006" (0.152mm) PER SIDE

** DIMENSION DOES NOT INCLUDE INTERLEAD FLASH. INTERLEAD FLASH SHALL NOT EXCEED 0.010" (0.254mm) PER SIDE

TYPICAL APPLICATION

CCD Clock Driver. Two 3rd Order Gaussian Filters Produce Clean CCD Clock Signals

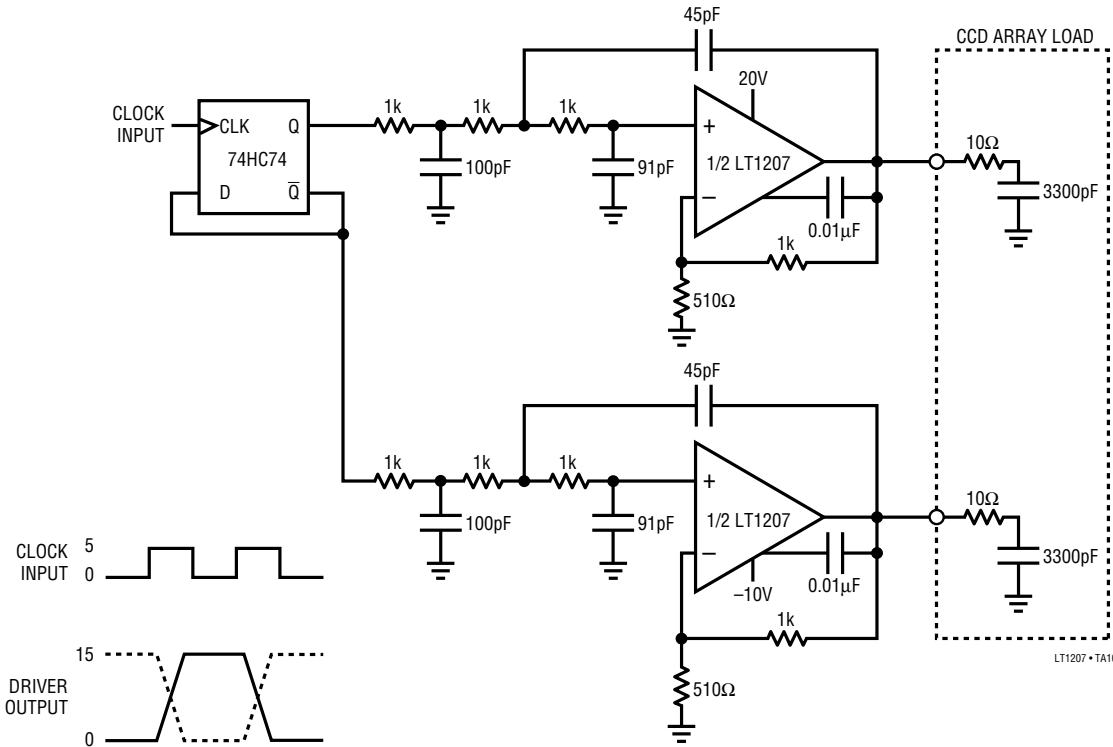

RELATED PARTS

PART NUMBER	DESCRIPTION	COMMENTS
LT1206	Single 250mA/60MHz Current Feedback Amplifier	Single Version of LT1207, 900V/ μ s Slew Rate, 0.02% Differential Gain, 0.17° Differential Phase, with $A_V = 2$ and $R_L = 30\Omega$, Stable with $C_L = 10,000\text{pF}$, Shutdown Control Reduces Supply Current to 200 μ A
LT1210	Single 1A/30MHz Current Feedback Amplifier	Higher Output Current Version of LT1206
LT1229/LT1230	Dual/Quad 100MHz Current Feedback Amplifiers	Low Cost CFA for Video Applications, 1000V/ μ s Slew Rate, 30mA Output Drive Current, 0.04% Differential Gain, 0.1° Differential Phase, with $A_V = 2$ and $R_L = 150\Omega$, 9.5mA Max Supply Current per Op Amp, $\pm 2\text{V}$ to $\pm 15\text{V}$ Supply Range
LT1360/LT1361/LT1362	Single/Dual/Quad 50MHz, 800V/ μ s, C-Load™ Op Amps	Fast Settling Voltage Feedback Amplifier, 60ns Settling Time to 0.1%, 10V Step, 5mA Max Supply Current per Op Amp, 9nV/ $\sqrt{\text{Hz}}$ Input Noise Voltage, Drives All Capacitive Loads, 1mV Max V_{OS} , 0.2% Differential Gain, 0.3° Differential Phase with $A_V = 2$ and $R_L = 150\Omega$

C-Load is a trademark of Linear Technology Corporation

Looking for pricing, stock, or lifecycle information?

Click below to explore more details on WIN SOURCE:

 [View LT1207CS#PBF on WIN SOURCE](#)

 [Linear Technology](#) Information

Optimize Your Supply Chain with WIN SOURCE Solutions

-  Global Sourcing Solution
-  Obsolete Management
-  Cost Control Management
-  Shortage Management
-  Alternative Solution
-  Excess Inventory Management