



**THE DATASHEET OF
LT1300CS8#TRPBF**



ABSOLUTE MAXIMUM RATINGS

V_{IN} Voltage	10V
SW1 Voltage	20V
Sense Voltage	10V
SHUTDOWN Voltage	10V
SELECT Voltage	10V
I_{LIM} Voltage	0.5V
Maximum Power Dissipation	500mW
Operating Temperature Range	0°C to 70°C
Storage Temperature Range	-65°C to 150°C
Lead Temperature (Soldering, 10 sec).....	300°C

PACKAGE/ORDER INFORMATION

	ORDER PART NUMBER
	LT1300CN8 LT1300CS8
	S8 PART MARKING
	1300

Consult factory for Industrial grade parts.

ELECTRICAL CHARACTERISTICS $T_A = 25^\circ\text{C}$, $V_{IN} = 2\text{V}$ unless otherwise noted.

SYMBOL	PARAMETER	CONDITIONS	MIN	TYP	MAX	UNITS	
I_Q	Quiescent Current	$V_{SHDN} = 0.5\text{V}$, $V_{SEL} = 5\text{V}$, $V_{SENSE} = 5.5\text{V}$ $V_{SHDN} = 1.8\text{V}$	●	120	200	μA	
			●	7	15	μA	
V_{IN}	Input Voltage Range		●	1.8		V	
			●	2.0		V	
V_{OUT}	Output Sense Voltage	$V_{SEL} = 5\text{V}$ $V_{SEL} = 0\text{V}$	●	4.80	5.0	5.20	V
			●	3.15	3.3	3.45	V
	Output Referred Comparator Hysteresis	$V_{SEL} = 5\text{V}$ (Note 1) $V_{SEL} = 0\text{V}$ (Note 1)	●	22	50	mV	
			●	14	35	mV	
	Oscillator Frequency	Current Limit not Asserted. See Test Circuit.	120	155	185	kHz	
	Oscillator TC			0.2		%/°C	
DC	Maximum Duty Cycle		75	86	95	%	
t_{ON}	Switch On Time	Current Limit not Asserted.		5.6		μs	
	Output Line Regulation	$1.8\text{V} < V_{IN} < 6\text{V}$	●	0.06	0.15	%/V	
V_{CESAT}	Switch Saturation Voltage	$I_{SW} = 700\text{mA}$	●	130	200	mV	
	Switch Leakage Current	$V_{SW} = 5\text{V}$, Switch Off	●	0.1	10	μA	
	Peak Switch Current (Internal Trip Point)	I_{LIM} Floating (See Typical Application) I_{LIM} Grounded		0.75	1.0	1.25	A
					0.4		A
V_{SHDNH}	Shutdown Pin High		●	1.8		V	
V_{SHDNL}	Shutdown Pin Low				0.5	V	
V_{SELH}	Select Pin High		●	1.5		V	
V_{SELL}	Select Pin Low		●		0.8	V	
I_{SHDN}	Shutdown Pin Bias Current	$V_{SHDN} = 5\text{V}$	●	9	20	μA	
		$V_{SHDN} = 2\text{V}$	●	3		μA	
		$V_{SHDN} = 0\text{V}$	●	0.1	1	μA	
I_{SEL}	Select Pin Bias Current	$0\text{V} < V_{SEL} < 5\text{V}$	●	1	3	μA	

The ● denotes specifications which apply over the 0°C to 70°C temperature range.

Note 1: Hysteresis specified is DC. Output ripple may be higher if output capacitance is insufficient or capacitor ESR is excessive. See applications section.

TYPICAL PERFORMANCE CHARACTERISTICS

Efficiency

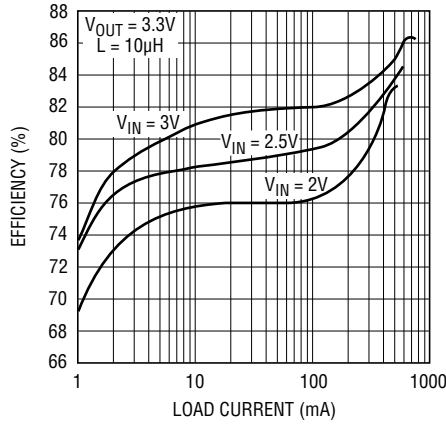

LT1300 G1

No-Load Battery Current

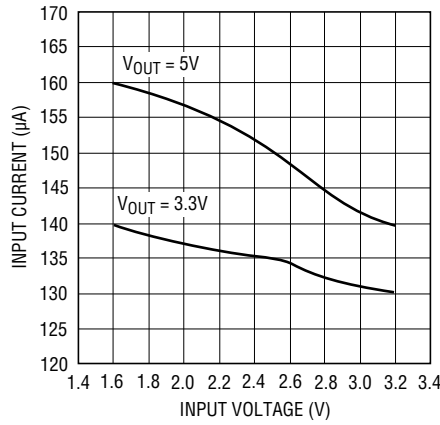

LT1300 G2

Total Quiescent Current in Shutdown

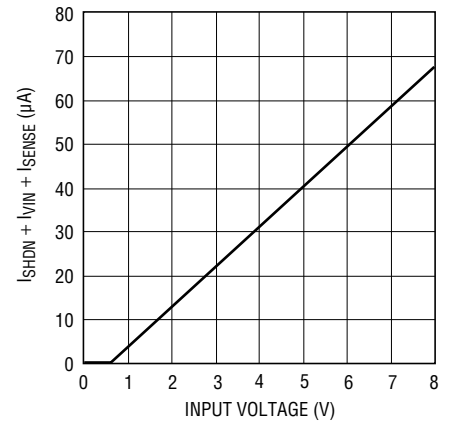

LT1300 G3

Shutdown Pin Bias Current

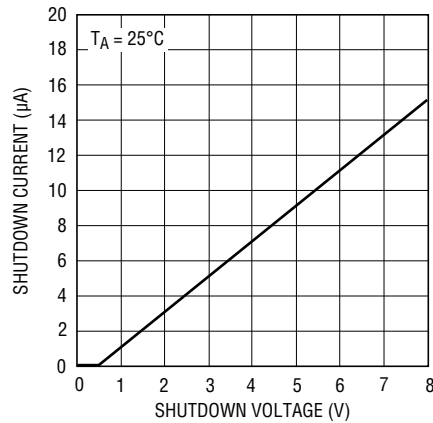

LT1300 G4

V_CESAT vs I_SW

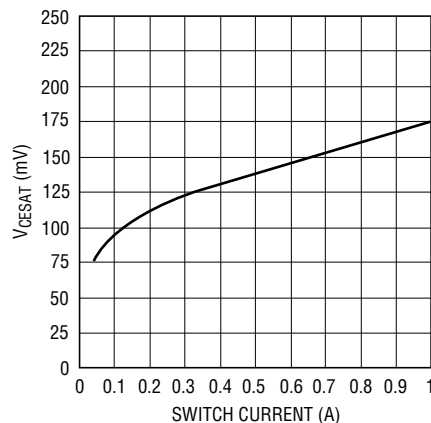

LT1300 G5

Maximum Output Current vs Input Voltage

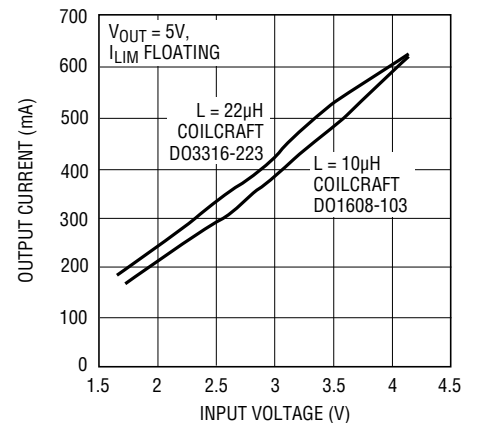

LT1300 G6

Maximum Output Current vs Input Voltage

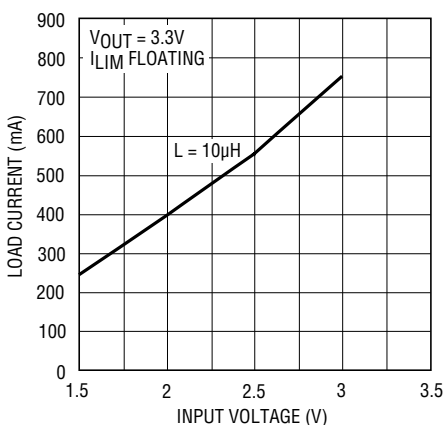

LT1300 G7

Transient Response
 $V_{IN} = 2V$, $V_{OUT} = 5V$

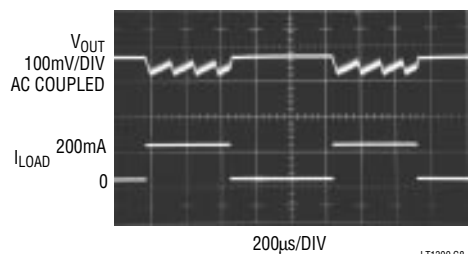

LT1300 G8

Startup Response

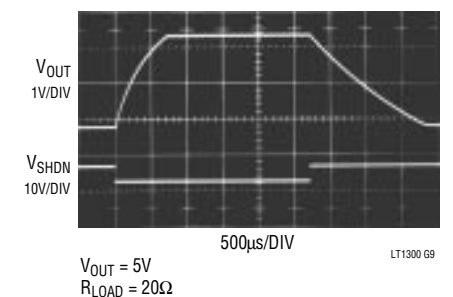

LT1300 G9

PIN FUNCTIONS

GND (Pin 1): Signal Ground.

SEL (Pin 2): Output Select. When tied to V_{IN} or V_{OUT} converter regulates at 5V. When grounded converter regulates at 3.3V.

SHDN (Pin 3): Shutdown. Pull high to effect shutdown. Tie to ground for normal operation.

Sense (Pin 4): "Output" Pin.

I_{LIM} (Pin 5): Float for 1A switch current limit. Tie to ground for approximately 400mA. A resistor between I_{LIM} and ground sets peak current to some intermediate value (see Figure 5).

V_{IN} (Pin 6): Supply Pin. Must be bypassed with a large value electrolytic to ground. A 0.1 μ F ceramic capacitor close to the pin may be needed in some cases.

SW (Pin 7): Switch Pin. Connect inductor and diode here. Keep layout short and direct to minimize electronic radiation.

PGND (Pin 8): Power Ground. Tie to signal ground (pin 1) under the package. Bypass capacitor from V_{IN} should be tied directly to the pin.

BLOCK DIAGRAM

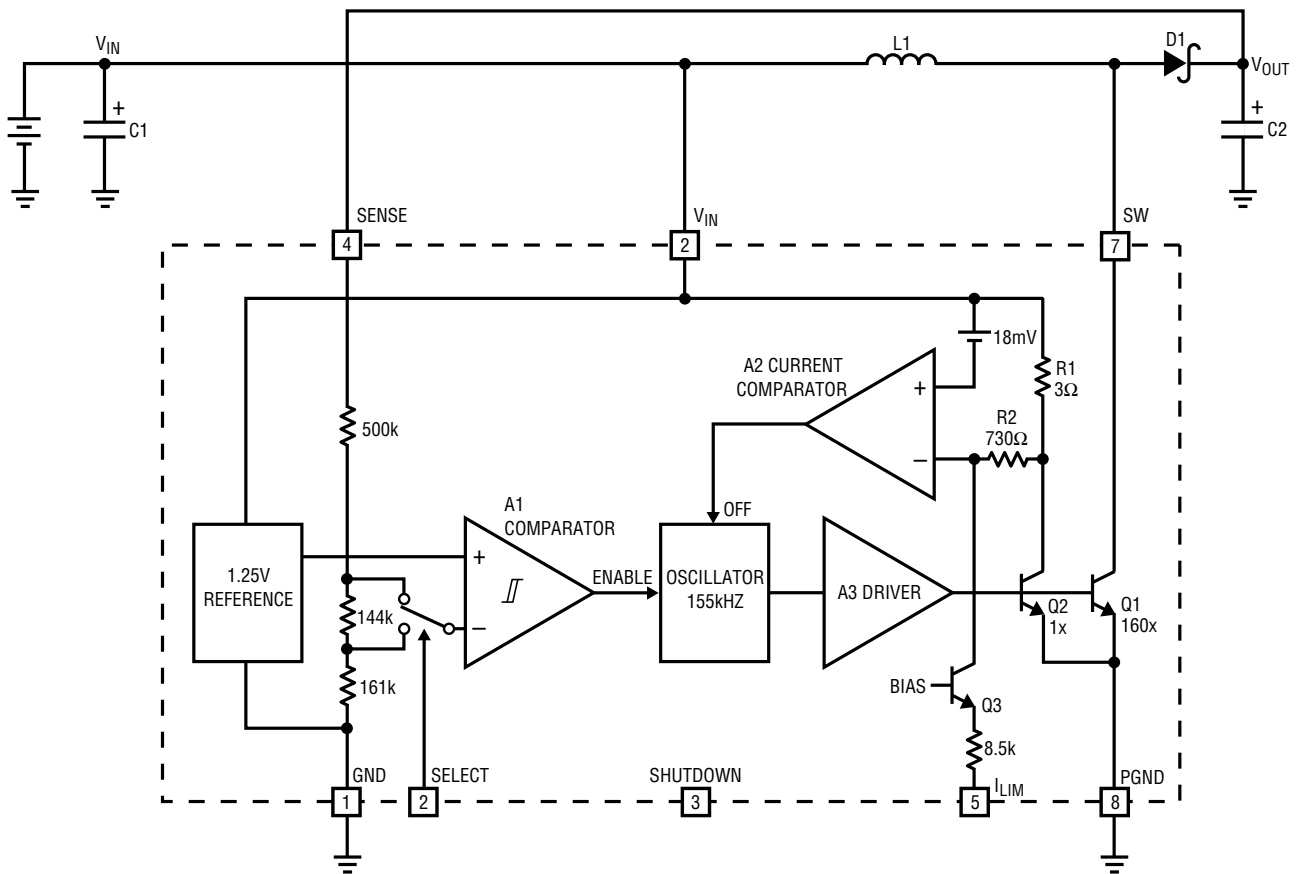

LT1300 F1

Figure 1.

TEST CIRCUIT

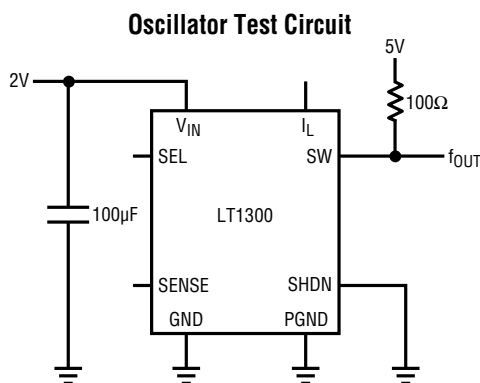

OPERATION

Operation of the LT1300 is best understood by referring to the Block Diagram in Figure 1. When A1's negative input, related to the Sense pin voltage by the appropriate resistor-divider ratio, is higher than the 1.25V reference voltage, A1's output is low. A2, A3 and the oscillator are turned off, drawing no current. Only the reference and A1 consume current, typically 120µA. When the voltage at A1's negative input decreases below 1.25V, overcoming A1's 6mV hysteresis, A1's output goes high, enabling the oscillator, current comparator A2, and driver A3. Quiescent current increases to 2mA as the device prepares for high current switching. Q1 then turns on in a controlled saturation for (nominally) 5.3µs or until current comparator A2 trips, whichever comes first. After a fixed off-time of (nominally) 1.2µs, Q1 turns on again. The LT1300's switching causes current to alternately build up in L1 and dump into capacitor C2 via D1, increasing the output voltage. When the output is high enough to cause A1's output to go to low, switching action ceases. C2 is left to supply current to the load until V_{OUT} decreases enough to force A1's output high, and the entire cycle repeats.

If switch current reaches 1A, causing A2 to trip, switch on-time is reduced and off-time increases slightly. This allows continuous mode operation during bursts. Current comparator A2 monitors the voltage across 3Ω resistor R1 which is directly related to inductor L1's current. Q2's collector current is set by the emitter-area ratio to 0.6% of Q1's collector current. When R1's voltage drop exceeds 18mV, corresponding to 1A inductor current, A2's output goes high, truncating the on-time portion of the oscillator cycle and increasing off-time to about 2µs as shown in Figure 2, trace A. This programmed peak current can be

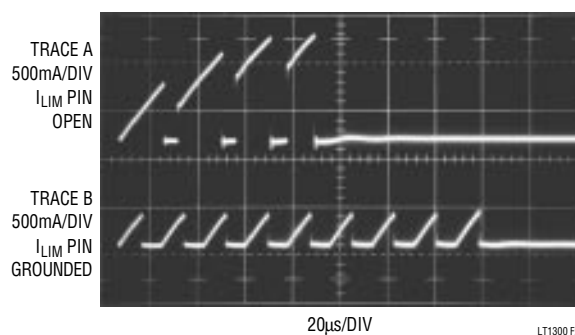

Figure 2. Switch Pin Current With I_{LIM} Floating or Grounded

reduced by tying the I_{LIM} pin to ground, causing 15µA to flow through R2 into Q3's collector. Q3's current causes a 10.4mV drop in R2 so that only an additional 7.6mV is required across R1 to turn off the switch. This corresponds to a 400mA switch current as shown in Figure 2, trace B. The reduced peak switch current reduces i²R losses in Q1, L1, C1 and D1. Efficiency can be increased by doing this provided that the accompanying reduction in full load output current is acceptable. Lower peak currents also extend alkaline battery life due to the alkaline cell's high internal impedance. Typical operating waveforms are shown in Figure 3.

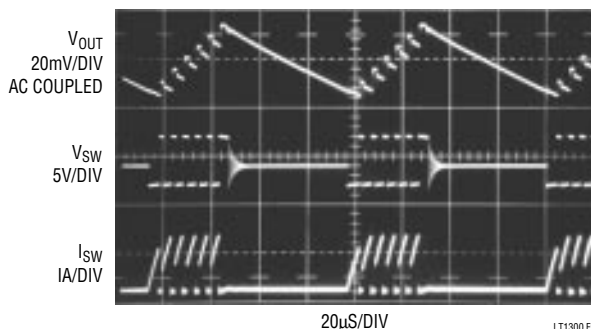

Figure 3. Burst Mode Operation in Action

APPLICATIONS INFORMATION

Output Voltage Selection

The LT1300 can be selected to 3.3V or 5V under logic control or fixed at either by tying SELECT to ground or V_{IN} respectively. It is permissible to tie SELECT to a voltage higher than V_{IN} as long as it does not exceed 10V. Efficiency in 3.3V mode will be slightly less than in 5V mode due to the fact that the diode drop is a greater percentage of 3.3V than 5V. Since the bipolar switch in the LT1300 gets its base drive from V_{IN} , no reduction in switch efficiency occurs when in 3.3V mode. When V_{IN} exceeds the programmed output voltage the output will follow the input. This is characteristic of the simple step-up or “boost” converter topology. A circuit example that provides a regulated output with an input voltage above or below the output (called a buck-boost or SEPIC) is shown in the Typical Applications section.

Shutdown

The converter can be turned off by pulling SHDN (pin 3) high. Quiescent current drops to $10\mu\text{A}$ in this condition. Bias current of $3\mu\text{A}$ to $5\mu\text{A}$ flows into the pin (at 2.5V input). It is recommended that SHDN not be left floating. Tie the pin to ground if the feature is not used.

I_{LIM} Function

The LT1300’s current limit (I_{LIM}) pin can be used for soft start. Upon start-up, switching regulators require maximum current from the supply. The high currents flowing can create IR drops along supply and ground lines and are especially demanding on alkaline batteries. By installing an R1 and C3 as shown in Figure 4, the switch current in the LT1300 is limited to 400mA until the $15\mu\text{A}$ flowing out of the I_{LIM} pin charges up the $0.1\mu\text{F}$ capacitor. Input current is held to under 500mA while the output voltage ramps up to 5V as shown in Figure 5. The 1Meg resistor provides a discharge path for the capacitor without appreciably decreasing peak switch current. When the full capability of the LT1300 is not required, peak current can be reduced by changing the value of R3 as shown in Figure 6. With $R3 = 0$, switch current is limited to approximately 400mA.

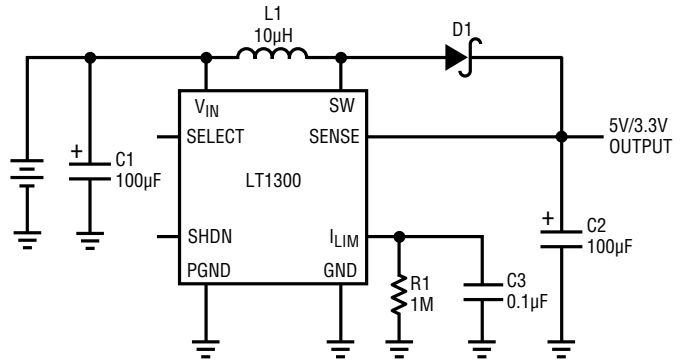

Figure 4. Addition of R1 and C3 Limit Input Current at Startup

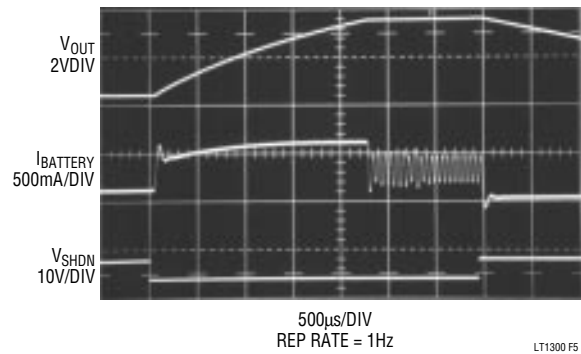

Figure 5. Startup Waveforms using Soft-Start Circuitry
 $I_{LOAD} = 100\text{mA}$, $V_{OUT} = 5\text{V}$

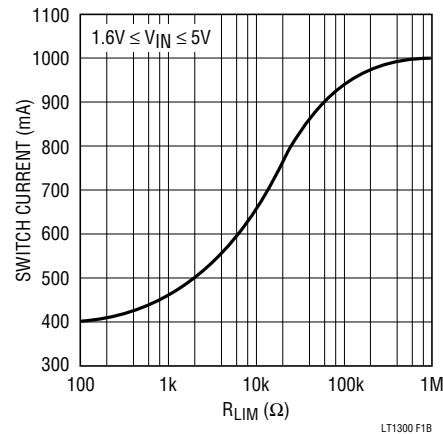

Figure 6. Peak Switch Current vs. R_{LIM}

APPLICATIONS INFORMATION

Table 1. Recommended Inductors

PART NUMBER	VENDOR	L (μ H)	DCR (Ω)	I _{LIM} PIN	EFFICIENCY 2.5V _{IN} , 5V _{OUT}		COMPONENT HEIGHT (mm)	PHONE NUMBER
					50mA LOAD	200mA LOAD		
DO1608-103	Coilcraft	10	0.11	Float	83	83	3.5	(708) 639-6400
DO3316-223	Coilcraft	22	0.050	Float	85	85	5.5	
DO1608-223	Coilcraft	22	0.31	Ground	85	—	3.5	
CTX10-1	Coiltronics	10	0.038	Float	85	85	4.2	(407) 241-7876
CTX20-1	Coiltronics	20	0.175	Ground	86	—	4.2	
LQH3C2204K0M00	Murata-Frie	22	0.7	Ground	81	—	2.0	(404) 436-1300
CD54-100M	Sumida	10	0.11	Float	85	85	4.5	(708) 956-0666
CDRH62-220M	Sumida	22	0.38	Ground	84	—	3.0	
CDRH62-100M	Sumida	10	0.17	Float	81	82	3.0	
GA10-102K	Gowanda	10	0.038	Float	85	86	6.6 Through-Hole	(716) 532-2234

Inductor Selection

For full output power, the inductor should have a saturation current rating of 1.25A for worst-case current limit, although it is acceptable to bias an inductor 20% or more into saturation. Smaller inductors can be used in conjunction with the I_{LIM} pin. Efficiency is significantly affected by inductor DCR. For best efficiency limit the DCR to 0.03 Ω or less. Toroidal types are preferred in some cases due to their closed design and inherent EMI/RFI superiority. Recommended inductors are listed in Table 1.

Capacitor Selection

Low ESR capacitors are required for both input and output of the LT1300. ESR directly affects ripple voltage and efficiency. For surface mount applications AVX TPS series tantalum capacitors are recommended. These have been specially designed for SMPS and have low ESR along with high surge current ratings. For through-hole application Sanyo OS-CON capacitors offer extremely low ESR in a small size. Again, if peak switch current is reduced using the I_{LIM} pin, capacitor requirements can be relaxed and smaller, higher ESR units can be used. Low frequency output ripple can be reduced by adding multiple output capacitors. If capacitance is reduced, output ripple will increase. Suggested capacitor sources are listed in Table 2.

Table 2. Recommended Capacitors

VENDOR	SERIES	TYPE	PHONE#
AVX	TPS	Surface Mount	(803)448-9411
Sanyo	OS-CON	Through-Hole	(619) 661-6835
Panasonic	HFQ	Through-Hole	(201) 348-5200

Diode Selection

Best performance is obtained with a Schottky rectifier diode such as the 1N5817. Phillips Components makes this in surface mount as the PRL5817. Motorola makes the MBRS130LT3 which is slightly better and also in surface mount. For lower output power a 1N4148 can be used although efficiency will suffer substantially.

Layout Considerations

The LT1300 is a high speed, high current device. The input capacitor must be no more than 0.2" from V_{IN} (pin 6) and ground. Connect the PGND and GND (pins 8 and 1) together under the package. Place the inductor adjacent to SW (pin 7) and make the switch pin trace as short as possible. This keeps radiated noise to a minimum.

TYPICAL APPLICATIONS

Four-Cell to 5V/3.3V Up-Down Converter

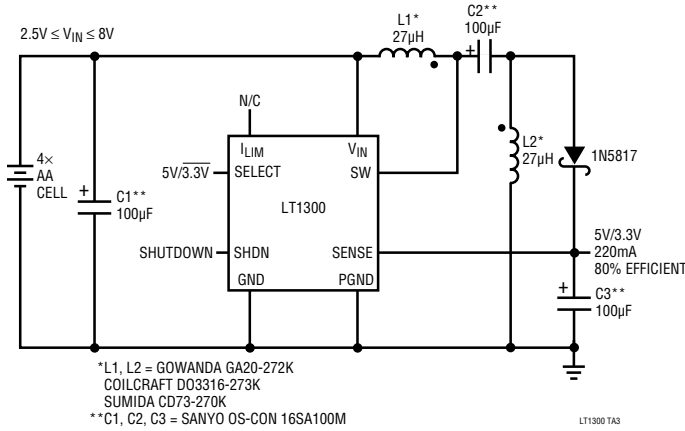

LCD Contrast Supply

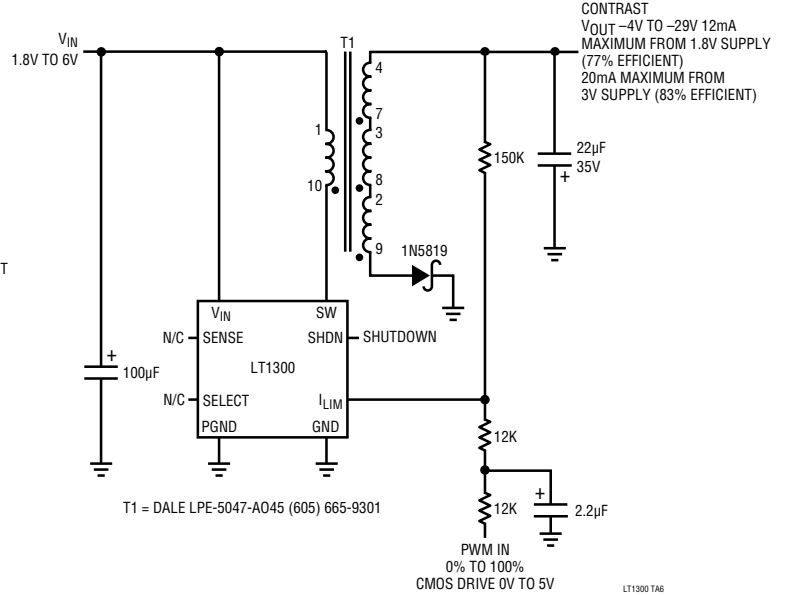

Step-Up Converter with Automatic Output Disconnect

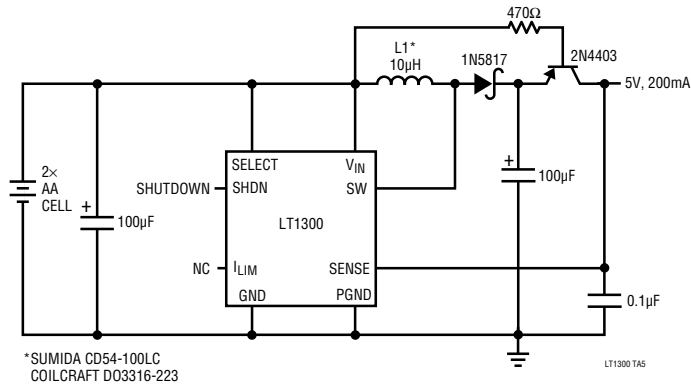

PACKAGE DESCRIPTION Dimensions in inches (millimeters) unless otherwise noted.

N8 Package 8-Lead Plastic DIP

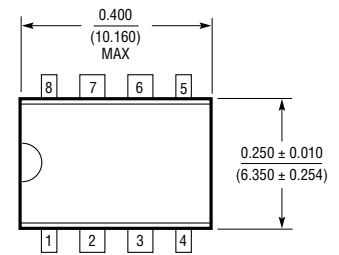
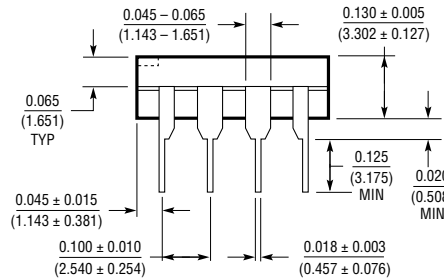
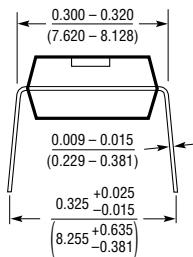

S8 Package 8-Lead Plastic SOIC

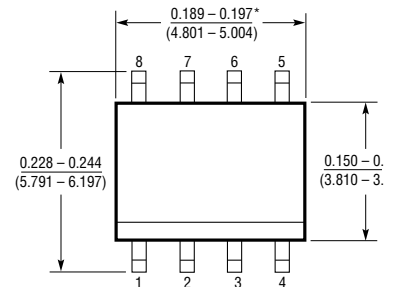
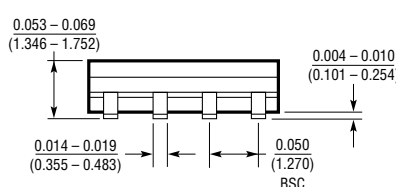
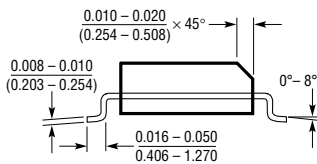

*THESE DIMENSIONS DO NOT INCLUDE MOLD FLASH OR PROTRUSIONS.
MOLD FLASH OR PROTRUSIONS SHALL NOT EXCEED 0.006 INCH (0.15mm).

Looking for pricing, stock, or lifecycle information?

Click below to explore more details on WIN SOURCE:

 [View LT1300CS8#TRPBF on WIN SOURCE](#)

 [Linear Technology](#) Information

Optimize Your Supply Chain with WIN SOURCE Solutions

-  Global Sourcing Solution
-  Obsolete Management
-  Cost Control Management
-  Shortage Management
-  Alternative Solution
-  Excess Inventory Management