



**THE DATASHEET OF
LT1303CS8-5#PBF**



Micropower High Efficiency DC/DC Converters with Low-Battery Detector Adjustable and Fixed 5V

FEATURES

- 5V at 200mA from a 2V Input
- Supply Voltage As Low As 1.8V
- Up to 88% Efficiency
- 120 μ A Quiescent Current
- Low-Battery Detector
- Low V_{CESAT} Switch: 170mV at 1A Typ
- Uses Inexpensive Surface Mount Inductors
- 8-Lead PDIP or SO Package

APPLICATIONS

- EL Panel Drivers
- 2-Cell and 3-Cell to 5V Conversion
- Palmtop Computers
- Portable Instruments
- Bar-Code Scanners
- PDAs
- Wireless Systems

DESCRIPTION

The LT[®]1303/LT1303-5 are micropower step-up high efficiency DC/DC converters using Burst Mode[™] operation. They are ideal for use in small, low-voltage battery-operated systems. The LT1303-5 accepts an input voltage between 1.8V and 5V and converts it to a regulated 5V. The LT1303 is an adjustable version that can supply an output voltage up to 25V. Quiescent current is only 120 μ A from the battery and the shutdown pin further reduces current to 10 μ A. The low-battery detector provides an open-collector output that goes low when the input voltage drops below a preset level. The on-chip NPN power switch has a low 170mV saturation voltage at a switch current of 1A. The LT1303/LT1303-5 are available in 8-lead PDIP or SO packages, easing board space requirements.

For higher output current, please see the LT1305 or LT1302.

LT, LTC and LT are registered trademarks of Linear Technology Corporation. Burst Mode is a trademark of Linear Technology Corporation.

TYPICAL APPLICATION

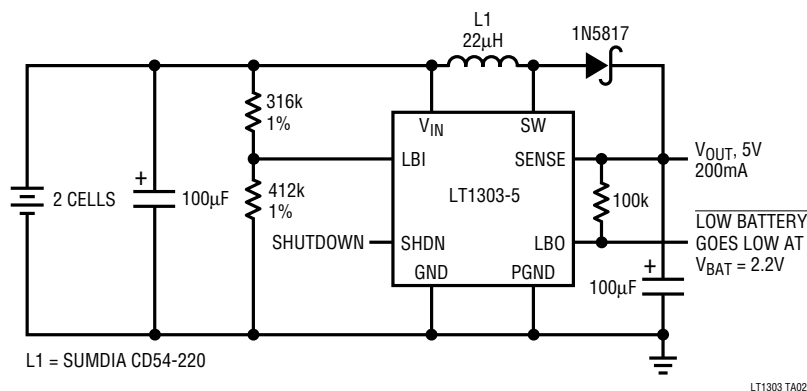
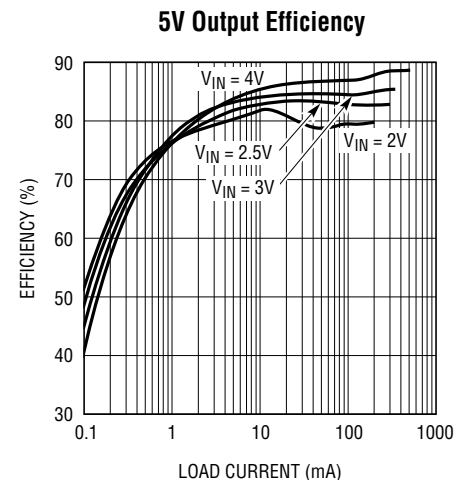

Figure 1. 2-Cell to 5V DC/DC Converter with Low-Battery Detect



ABSOLUTE MAXIMUM RATINGS

V_{IN} Voltage	10V
SW1 Voltage	25V
Sense Voltage (LT1303-5)	20V
FB Voltage (LT1303)	10V
Shutdown Voltage	10V
LBO Voltage	10V
LBI Voltage	10V
Maximum Power Dissipation	500mW
Operating Temperature Range	0°C to 70°C
Storage Temperature Range	-65°C to 150°C
Lead Temperature (Soldering, 10 sec).....	300°C

PACKAGE/ORDER INFORMATION

<p>TOP VIEW</p> <p>N8 PACKAGE 8-LEAD PDIP</p> <p>S8 PACKAGE 8-LEAD PLASTIC SO</p> <p>*FIXED VERSION</p> <p>$T_{JMAX} = 100^{\circ}C, \theta_{JA} = 130^{\circ}C/W$ (N8) $T_{JMAX} = 100^{\circ}C, \theta_{JA} = 150^{\circ}C/W$ (S8)</p>	ORDER PART NUMBER
	<p>LT1303CN8</p> <p>LT1303CS8</p> <p>LT1303CN8-5</p> <p>LT1303CS8-5</p>
	S8 PART MARKING
	<p>1303</p> <p>13035</p>

Consult factory for Industrial and Military grade parts.

ELECTRICAL CHARACTERISTICS $T_A = 25^{\circ}C, V_{IN} = 2.0V$, unless otherwise noted.

SYMBOL	PARAMETER	CONDITIONS	MIN	TYP	MAX	UNITS	
I_Q	Quiescent Current	$V_{SHDN} = 0.5V, V_{SEL} = 5V, V_{SENSE} = 5.5V$ $V_{SHDN} = 1.8V$	●	120	200	μA	
			●	7	15	μA	
V_{IN}	Input Voltage Range		●	1.8	1.55	V	
			●	2.0		V	
	Feedback Voltage	LT1303	●	1.22	1.24	1.26	V
	Output Sense Voltage	LT1303-5	●	4.8	5.0	5.2	V
	Comparator Hysteresis	LT1303 (Note 1)	●	6	12.5	mV	
	Output Hysteresis	LT1303-5 (Note 1)	●	22	50	mV	
	Feedback Pin Bias Current	LT1303, $V_{FB} = 1V$	●	7	20	nA	
	Oscillator Frequency	Current Limit Not Asserted		120	155	185	kHz
	Oscillator TC			0.2		%/°C	
DC	Maximum Duty Cycle		●	75	86	95	%
t_{ON}	Switch On Time	Current Limit Not Asserted		5.6		μs	
	Output Line Regulation	$1.8V < V_{IN} < 6V$	●	0.06	0.15	%/V	
V_{CESAT}	Switch Saturation Voltage	$I_{SW} = 700mA$	●	130	200	mV	
	Switch Leakage Current	$V_{SW} = 5V$, Switch Off	●	0.1	10	μA	
	Peak Switch Current	$V_{IN} = 2V$ $V_{IN} = 5V$	●	0.75	1.0	1.25	A
			●	0.65	0.9	1.15	A
	LBI Trip Voltage		●	1.21	1.24	1.27	V
	LBI Input Bias Current	$V_{LBI} = 1V$	●	7	20	nA	
	LBO Output Low	$I_{LOAD} = 100\mu A$	●	0.11	0.4	V	
	LBO Leakage Current	$V_{LBI} = 1.3V, V_{LBO} = 5V$	●	0.1	5	μA	
V_{SHDNH}	Shutdown Pin High		●	1.8		V	
V_{SHDNL}	Shutdown Pin Low				0.5	V	
I_{SHDN}	Shutdown Pin Bias Current	$V_{SHDN} = 5V$ $V_{SHDN} = 2V$ $V_{SHDN} = 0V$	●	8.0	20	μA	
			●	3.0		μA	
			●	0.1	1	μA	

The ● denotes specifications which apply over the 0°C to 70°C operating temperature range.

Note 1: Hysteresis specified is DC. Output ripple may be higher if output capacitance is insufficient or capacitor ESR is excessive.

TYPICAL PERFORMANCE CHARACTERISTICS

V_{CESAT} vs Switch Current

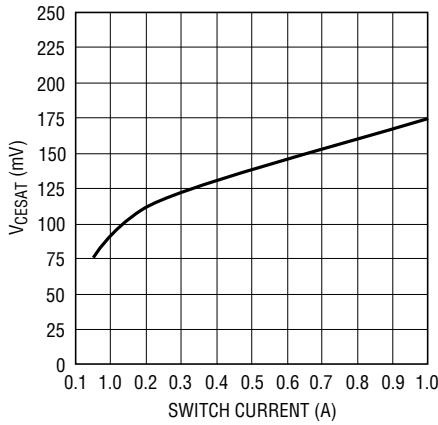

LT1303 G01

V_{CESAT} vs Temperature

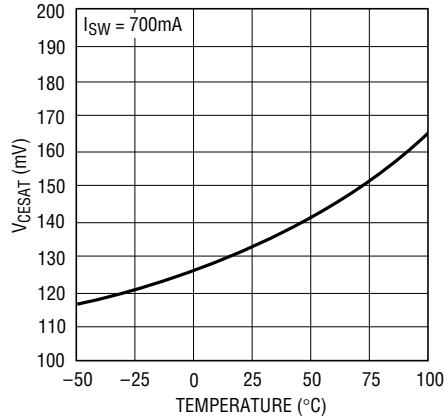

LT1303 G02

LT1303-5 Sense Pin Resistance to Ground

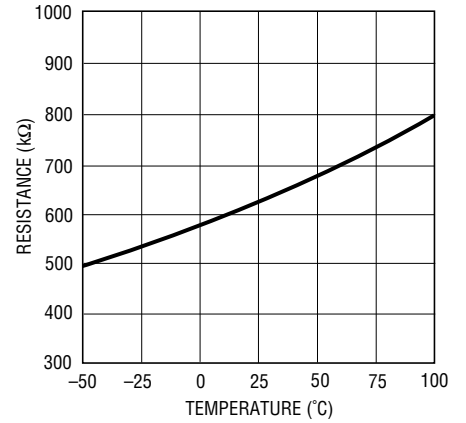

LT1303 G03

LT1303 FB Voltage

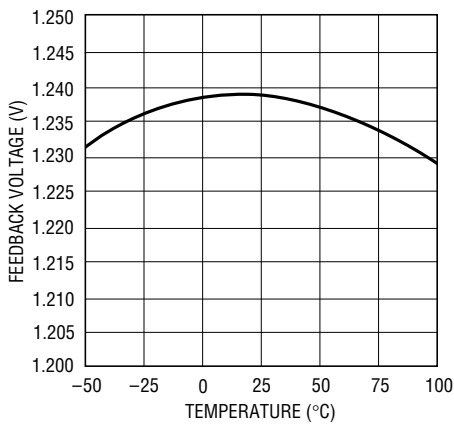

LT1303 G04

LT1303-5 Sense Voltage

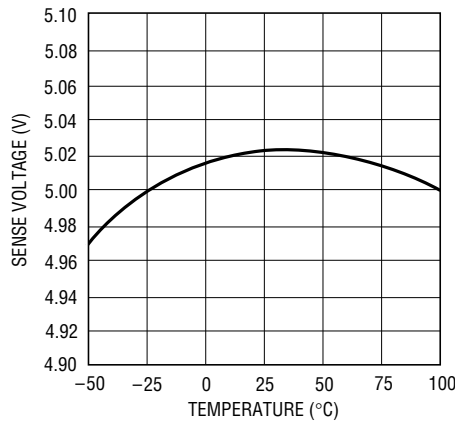

LT1303 G05

Low Battery Detect Trip Point

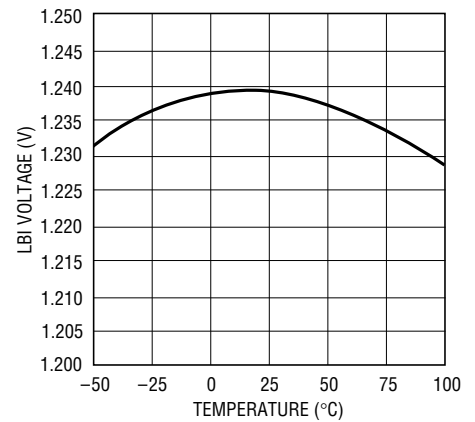

LT1303 G06

LBI Pin Bias Current

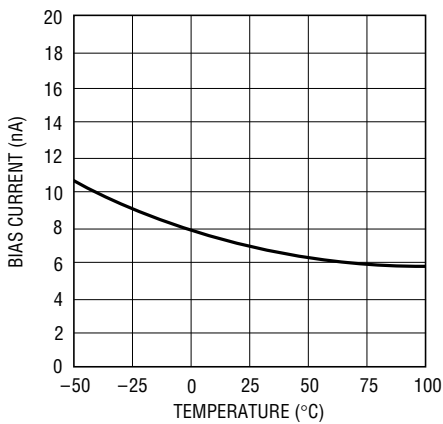

LT1303 G07

FB Pin Bias Current

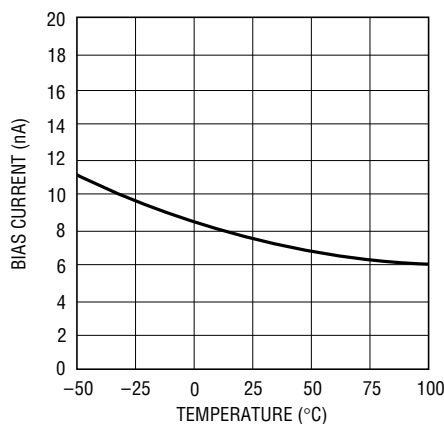

LT1303 G08

Switch Current Limit

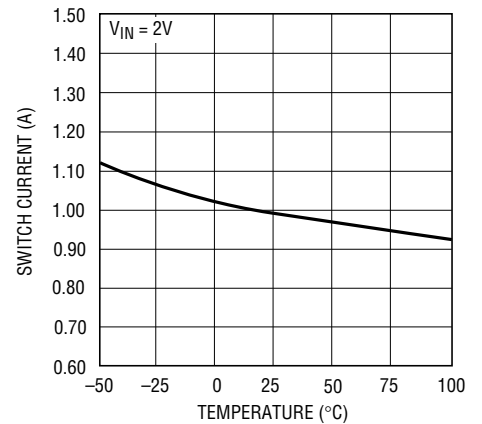

LT1303 G09

TYPICAL PERFORMANCE CHARACTERISTICS

Switch On-Time

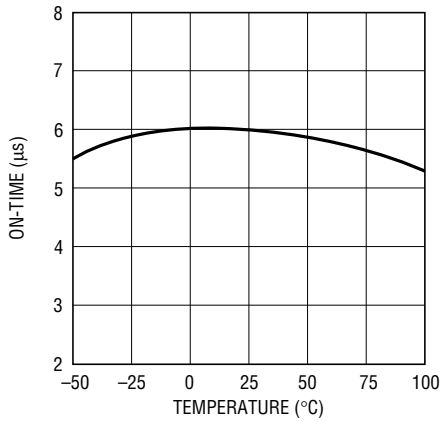

LT1303 G10

Oscillator Frequency

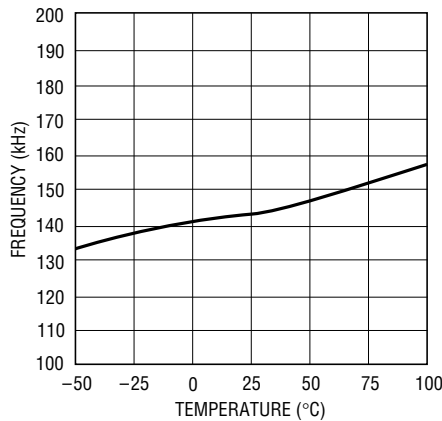

LT1303 G11

Maximum Duty Cycle

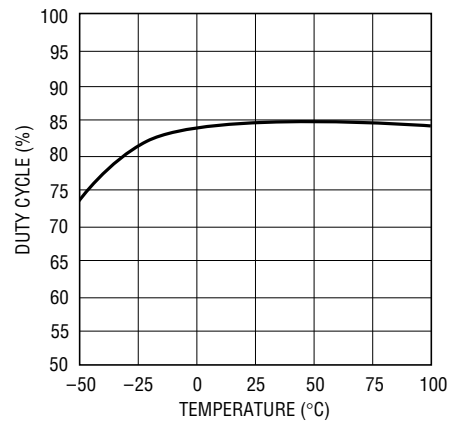

LT1303 G12

Quiescent Current

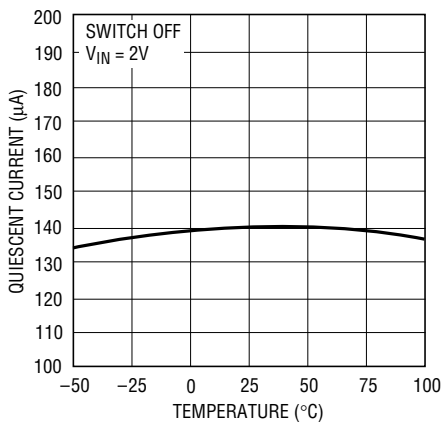

LT1303 G13

Quiescent Current

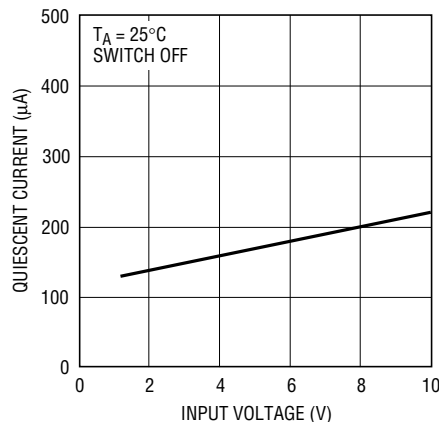

LT1303 G14

Switch Current Limit

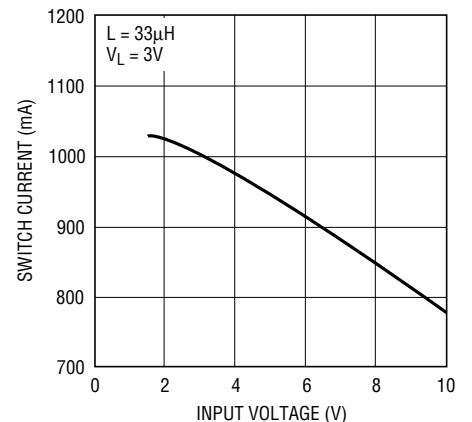

LT1303 G15

**Transient Response
Figure 1 Circuit**

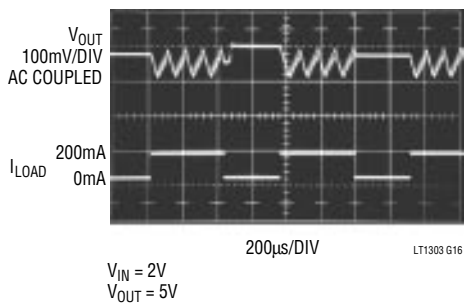

LT1303 G16

Shutdown Pin Response

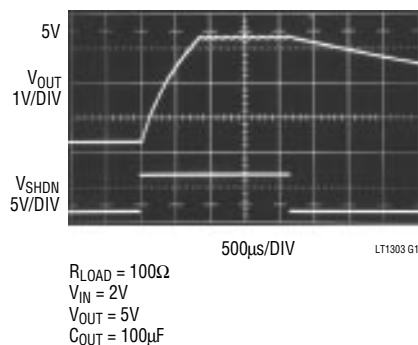

LT1303 G17

Low Battery Detector Transient Response

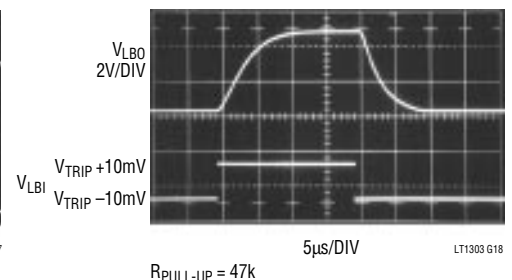

LT1303 G18

PIN FUNCTIONS

GND (Pin 1): Signal Ground. Tie to PGND under the package.

LBO (Pin 2): Open-Collector Output of Low-Battery Comparator. Can sink 100 μ A. Disabled when device is in shutdown.

SHDN (Pin 3): Shutdown. Pull high to shut down the device. Ground for normal operation.

FB/Sense (Pin 4): On 1303 (adjustable) this pin connects to the main comparator C1 input. On LT1303-5 this pin connects to the resistor string that sets output voltage at 5V.

LBI (Pin 5): Low-Battery Comparator Input. When voltage on this pin below 1.24V, LBO is low.

V_{IN} (Pin 6): Supply Pin. Must be bypassed with a large value electrolytic to ground. Keep bypass within 0.2" of the device.

SW (Pin 7): Switch Pin. Connect inductor and diode here. Keep layout short and direct to minimize radio frequency interference.

PGND (Pin 8): Power ground. Tie to signal ground (pin1) under the package. Bypass capacitor from V_{IN} should be tied directly to PGND within 0.2" of the device.

BLOCK DIAGRAMS

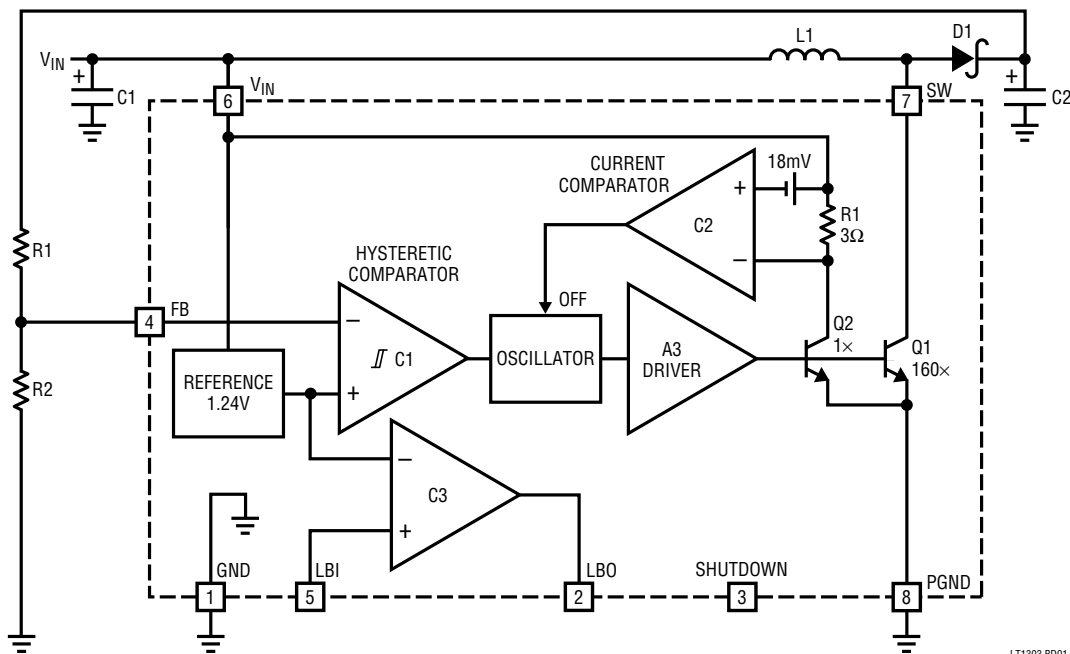

Figure 2. LT1303 Block Diagram

LT1303 8001

BLOCK DIAGRAMS

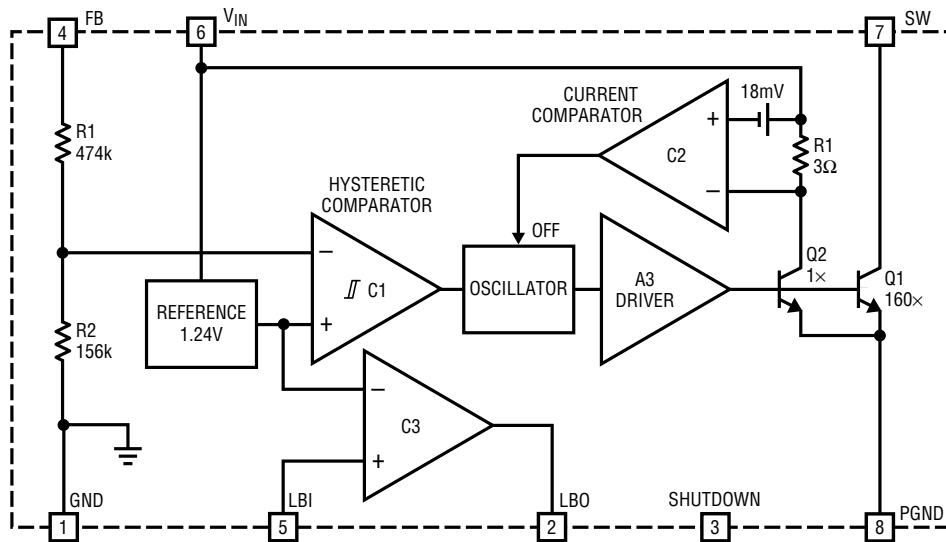

Figure 3. LT1303-5 Block Diagram

LT1303 8002

OPERATION

Operation of the LT1303 is best understood by referring to the Block Diagram in Figure 2. When C1's negative input, related to the output voltage by the appropriate resistor-divider ratio, is higher than the 1.24V reference voltage, C1's output is low. C2, A3 and the oscillator are turned off, drawing no current. Only the reference and C1 consume current, typically 140 μ A. When C1's negative input drops below 1.24V and overcomes C1's 6mV hysteresis, C1's output goes high, enabling the oscillator, current comparator C2 and driver A3. Quiescent current increases to 2mA as the device goes into active switching mode. Q1 then turns on in controlled saturation for nominally 6 μ s or until current comparator C2 trips, whichever comes first. The switch then turns off for approximately 1.5 μ s, then turns on again. The LT1303's switching causes current to alternately build up in L1 and dump into output capacitor C4 via D1, increasing the output voltage. When the output is high enough to cause C1's output to go high, switching action ceases. Capacitor C4 is left to supply current to the load until V_{OUT} decreases enough to force C1's output high, and the entire cycle repeats. Figure 4 details relevant waveforms. C1's cycling causes low-to-mid-frequency ripple voltage on the output. Ripple can be reduced by making the

output capacitor large. The 100 μ F unit specified results in ripple of 50mV to 100mV on the 5V output. A 220 μ F capacitor will decrease ripple by approximately 50%.

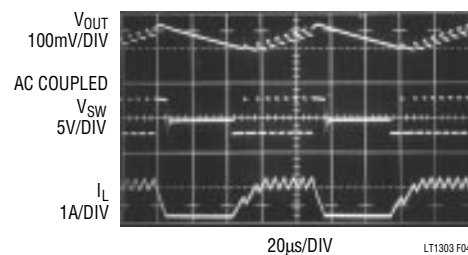

Figure 4. Burst Mode Operation in Action

If switch current reaches 1A, causing C2 to trip, switch on-time is reduced and off-time increases slightly. This allows continuous operation during bursts. C2 monitors the voltage across 3 Ω resistor R1 which is directly related to the switch current. Q2's collector current is set by the emitter-area ratio to 0.6% of Q1's collector current. When R1's voltage drop exceeds 18mV, corresponding to 1A switch current, C2's output goes high, truncating the on-time portion of the oscillator cycle and increasing off-time

OPERATION

to about 2μs. Response time of C2, which determines minimum on-time, is approximately 300ns.

Low Battery Detector

The low battery detector is enabled when SHDN is low and disabled when SHDN is high. The comparator has no

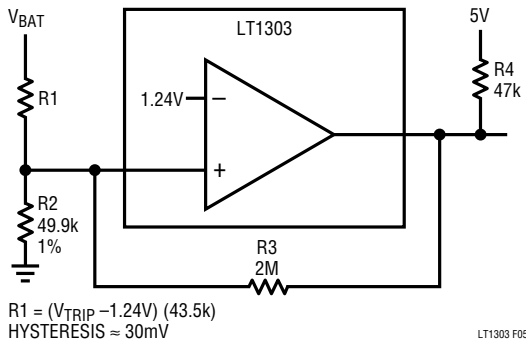

Figure 5. R3 Adds Hysteresis to Low-Battery Detector

hysteresis built in, but hysteresis can be added by connecting a high-value resistor from LBI to LBO as shown in Figure 5. The internal reference can be accessed via the comparator as shown in Figure 6.

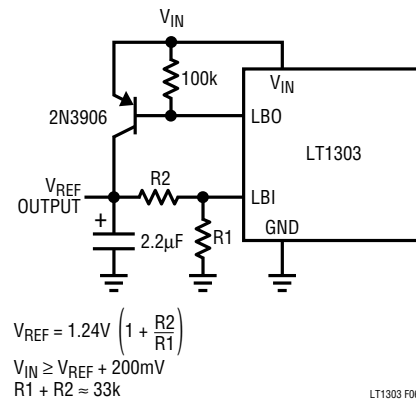

Figure 6. Accessing Internal Reference

APPLICATIONS INFORMATION

Inductor Section

Inductors suitable for use with the LT1303 usually fall in the 5μH to 50μH range. The inductor must: (1) handle current of 1.25A without saturating, (2) have enough inductance to provide a di/dt lower than 400mA/μs, and (3) have low enough DC resistance to avoid excessive heating or efficiency losses. Higher value inductors will deliver more power but tend to be physically larger. Most ferrite core drum or rod inductors such as those specified in Table 1 are suitable for use. It is acceptable to bias open-flux inductors (e.g. Sumida CD54) into saturation by 10 to 20% without adverse effects.

Table 1. Recommended Inductors

VENDOR	SERIES	APPROPRIATE VALUES	PHONE NUMBERS
Coilcraft	D03316 D01608	10μH to 47μH 10μH	(708) 639-6400
Coiltronics	OCTAPAK CTX20-1 CTX20-2 CTX33-4	20μH 20μH 33μH	(407) 241-7876
Sumida	CD54	10μH to 33μH	(708) 956-0666
Gowanda	GA10	10μH to 33μH	(716) 532-2234

Figure 7 shows inductor current of a suitable inductor, di/dt is controlled at all times. The rapid rise in current shown in Figure 8 results from this inductor saturating at approximately 1A. Saturation occurs when the inductor cannot hold any more magnetic energy in the core. Current then increases rapidly, limited only by the resistance of the winding. Figure 9's inductor has high DC resistance which results in the exponential time constant shape of the inductor current.

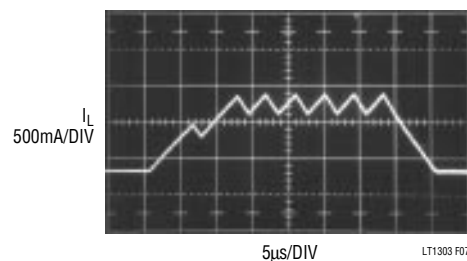

Figure 7. Properly Chosen Inductor Does Not Saturate

APPLICATIONS INFORMATION

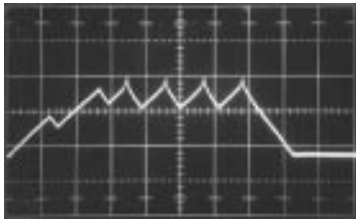

Figure 8. This Inductor Saturates at $I_L \approx 1A$. A Poor Choice

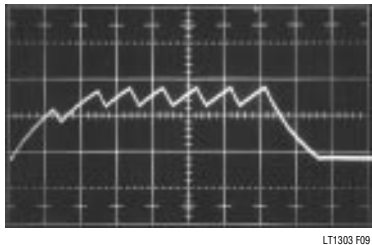

Figure 9. Slight Exponential Shape to Inductor Current Waveform Indicates Excessive DC Resistance

Diode Selection

The LT1303's high switching speed demands a high speed rectifier. Schottky diodes are preferred for their low forward drop and fast recovery. Suitable choices include the 1N5817, MBR5120LT3, and MBR0520LT1. Do not use signal diodes such as 1N4148. They cannot carry 1A current. Also avoid "general-purpose" diodes such as 1N4001. These are far too slow and are unsuitable for any switching regulator application. For high temperature applications a silicon diode such as the MUR105 will have less leakage.

Capacitor Selection

Input and output capacitors should have low ESR for best efficiency. Recommended capacitors include AVX TPS series, Sprague 595D series, and Sanyo OS-CON. The output capacitor's ESR determines the high frequency ripple amplitude. A $100\mu F$ capacitor is the minimum recommended for a 5V output. Higher output voltages can use lower capacitance values. For example, a 12V output can use a $33\mu F$ or $47\mu F$ capacitor. The V_{IN} pin of the LT1303 should be decoupled with a $47\mu F$ or $100\mu F$ capacitor at the pin. When driving a transformer, an additional decoupling network of 10Ω and $0.1\mu F$ ceramic is recommended as shown in Figure 10.

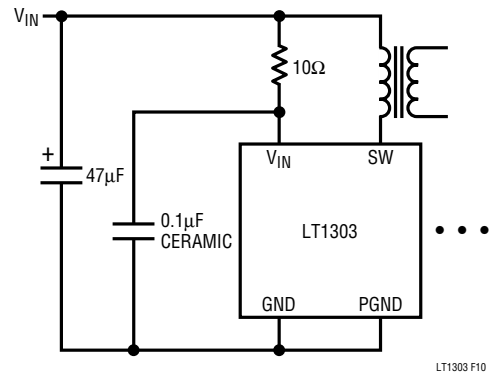

Figure 10. 10Ω - $1\mu F$ Network to LT1303 V_{IN} Pin Provides Additional Decoupling. Recommended When Driving Transformers.

Table 2. Recommended Capacitors

VENDOR	SERIES	TYPE	PHONE NUMBERS
AVX	TPS	Surface Mount	(803) 448-9411
Sanyo	OS-CON	Through-Hole	(619) 661-6835
Panasonic	HFQ	Through-Hole	(201) 348-5200
Sprague	595D	Surface Mount	(603) 224-1961

TYPICAL APPLICATIONS

Setting Output Voltage on LT1303

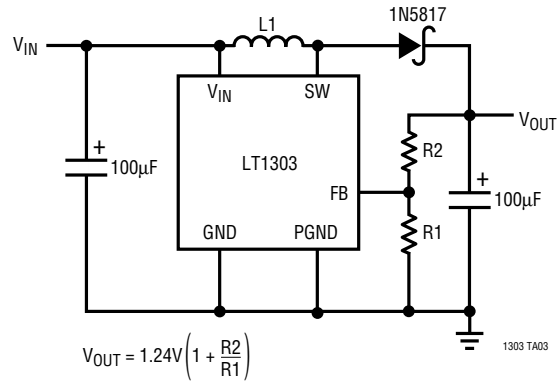

5V Step-Up Converter with Reference Output

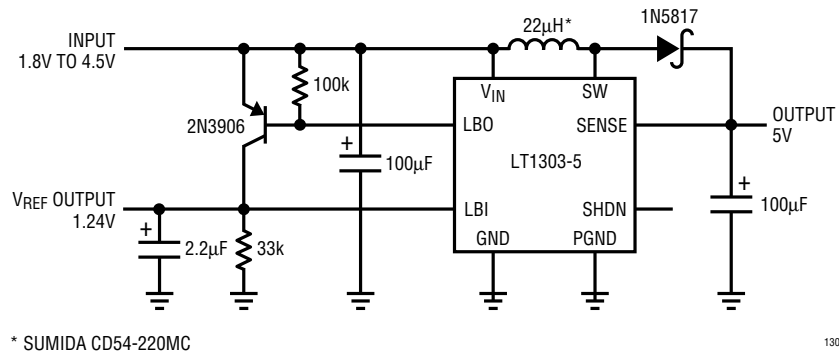

TYPICAL APPLICATIONS

4-, 5-Cell to 5V Converter with Output Disconnect

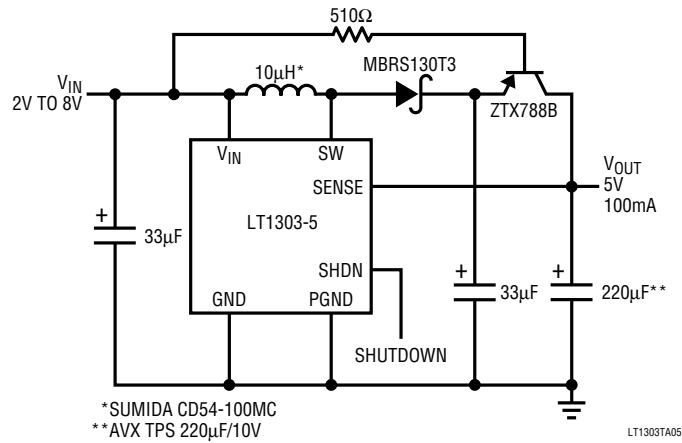

3-Cell to 3.3V Boost/Linear Converter with Output Disconnect

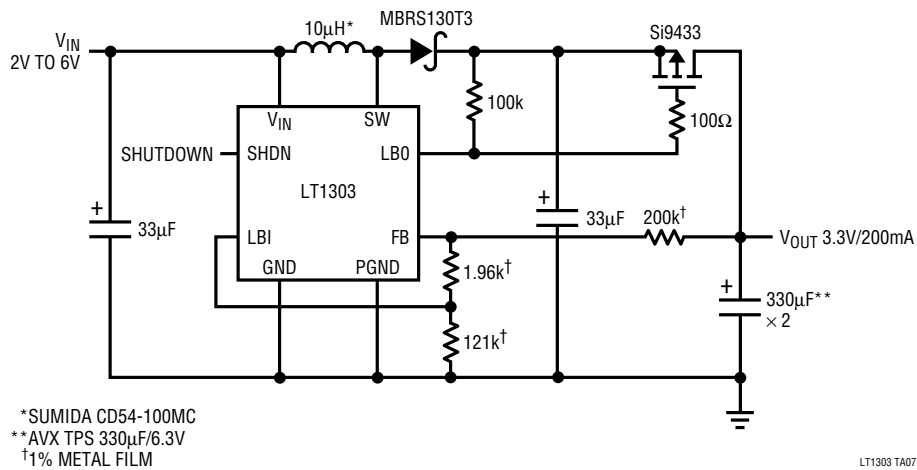

TYPICAL APPLICATIONS

EL Panel Driver

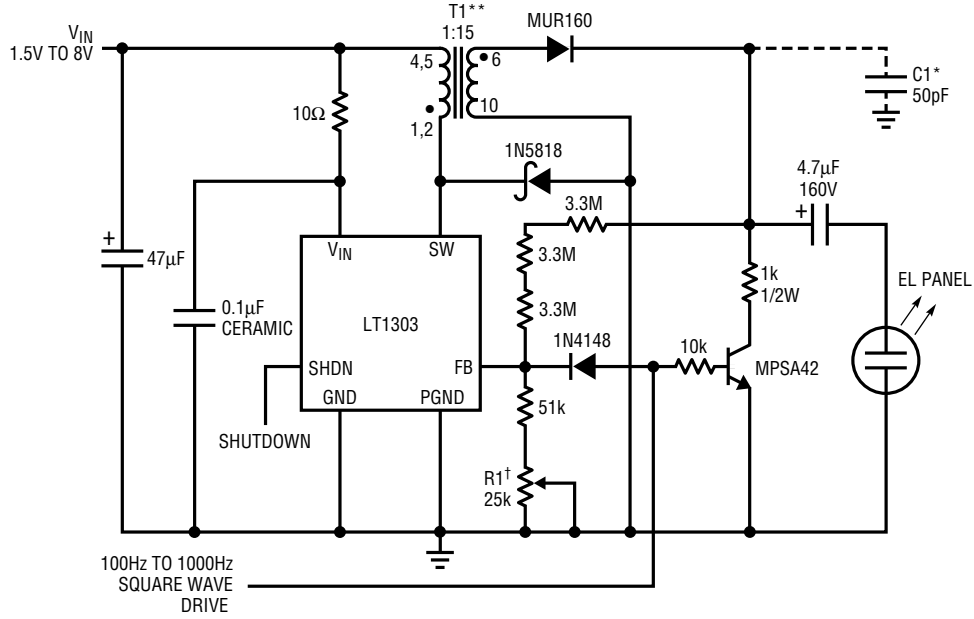

*ADD C1 FOR OPEN-PANEL PROTECTION
 **DALE LPE5047-A132 1:15 TURNS RATIO (605) 666-9301
 †R1 ADJUSTS V_{OUT} 83V_{RMS} TO 115V_{RMS}

LT1303 TA06

PACKAGE DESCRIPTION Dimensions in inches (millimeters) unless otherwise noted.

**N8 Package
8-Lead Plastic DIP**

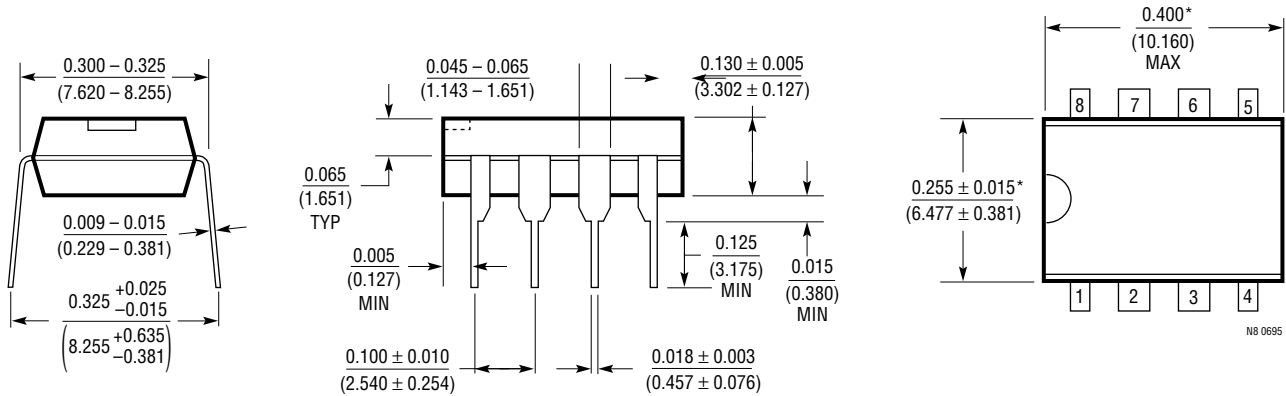

*THESE DIMENSIONS DO NOT INCLUDE MOLD FLASH OR PROTRUSIONS.
MOLD FLASH OR PROTRUSIONS SHALL NOT EXCEED 0.010 INCH (0.254mm)

**S8 Package
8-Lead Plastic SOIC**

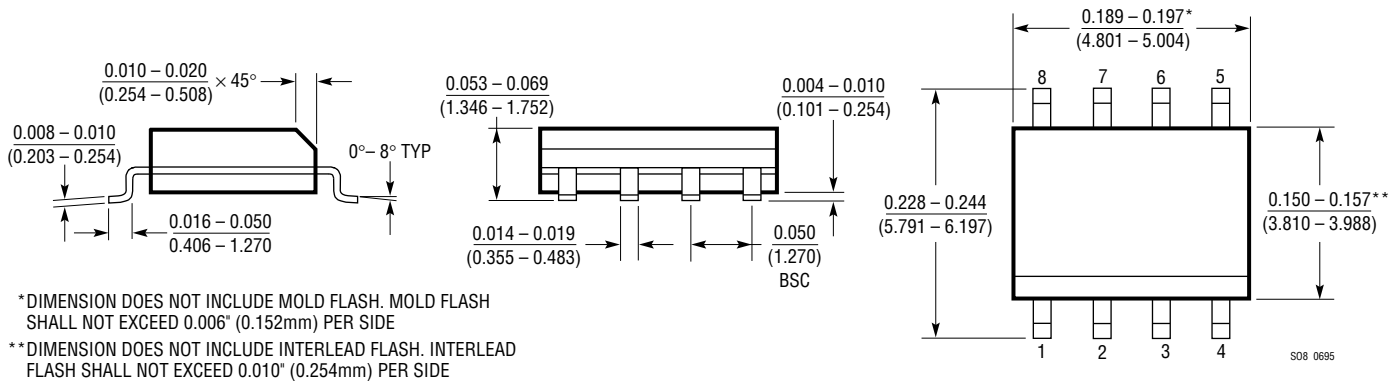

DIMENSION DOES NOT INCLUDE MOLD FLASH. MOLD FLASH SHALL NOT EXCEED 0.006 (0.152mm) PER SIDE
**DIMENSION DOES NOT INCLUDE INTERLEAD FLASH. INTERLEAD FLASH SHALL NOT EXCEED 0.010* (0.254mm) PER SIDE

RELATED PARTS

PART NUMBER	DESCRIPTION	COMMENTS
LT1129	Micropower Low Dropout Regulator	700mA Output Current in SO-8 Package
LT1182/83/84	LCD and CCFL Backlight Controller	High Efficiency and Excellent Backlight Control Range
LT1301	5V to 12V/200mA Step-Up DC/DC Converter	120µA Quiescent Current
LT1302	2-Cell to 5V/600mA Step-Up DC/DC Converter	200µA Quiescent Current
LT1305	Micropower 2A Switch DC/DC Converter with Low-Battery Detect	2V to 5V at 400mA
LT1372	500kHz Step-Up PWM, 1.5A Switch	Low Noise, Fixed Frequency Operation
LTC®1472	PCMCIA Host Switch with Protection	Includes Current Limit and Thermal Shutdown

Looking for pricing, stock, or lifecycle information?

Click below to explore more details on WIN SOURCE:

 [View LT1303CS8-5#PBF on WIN SOURCE](#)

 [Linear Technology](#) Information

Optimize Your Supply Chain with WIN SOURCE Solutions

-  Global Sourcing Solution
-  Obsolete Management
-  Cost Control Management
-  Shortage Management
-  Alternative Solution
-  Excess Inventory Management