



**THE DATASHEET OF**  
**LT1308IS8#PBF**



# Single Cell High Current Micropower 600kHz Boost DC/DC Converter

January 1998

## FEATURES

- **5V at 1A from a Single Li-Ion Cell**
- **3.3V at 300mA from a Single NiCd Cell**
- Low Quiescent Current: 100 $\mu$ A
- Operates with  $V_{IN}$  as Low as 1V
- Fixed Frequency Operation: 600kHz
- **Current Mode PWM Delivers Low Output Ripple**
- Guaranteed Start-Up into Full Load
- Low Shutdown Current: 3 $\mu$ A
- Low-Battery Comparator
- Automatic Burst Mode™ Operation at Light Load
- Low  $V_{CESAT}$  Switch: 300mV at 2A

## APPLICATIONS

- GSM Terminals
- Digital Cameras
- Answer-Back Pagers
- Cordless Telephones
- DECT Phones
- GPS Receivers
- Battery Backup Supplies

## DESCRIPTION

The LT<sup>®</sup>1308 is a micropower, fixed frequency boost DC/DC converter that operates from an input voltage as low as 1V. Capable of delivering 5V at load current of 1A from a single Li-Ion cell, the LT1308 also features power saving Burst Mode operation at light loads. High efficiency is maintained over a broad 1mA to 1A load range.

The device contains a low-battery detector with a 200mV reference and shuts down to less than 5 $\mu$ A quiescent current. No-load quiescent current is 100 $\mu$ A and the internal NPN power switch handles a 2A current with a voltage drop of just 300mV.

High frequency 600kHz switching allows the use of small, surface mount components. The LT1308's current mode architecture provides fast response to load and line variations. The device is available in an 8-lead SO package.

LT, LTC and LT are registered trademarks of Linear Technology Corporation. Burst Mode is a trademark of Linear Technology Corporation.

## TYPICAL APPLICATION

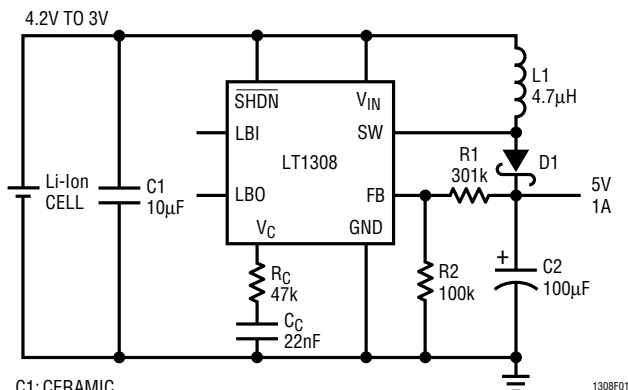

C1: CERAMIC  
 C2: AVX TPS SERIES  
 D1: INTERNATIONAL RECTIFIER 10BQ015  
 L1: COILTRONICS CTX5-1  
 COILCRAFT D03316-472

Figure 1. Single Li-Ion Cell to 5V/1A DC/DC Converter

### Converter Efficiency

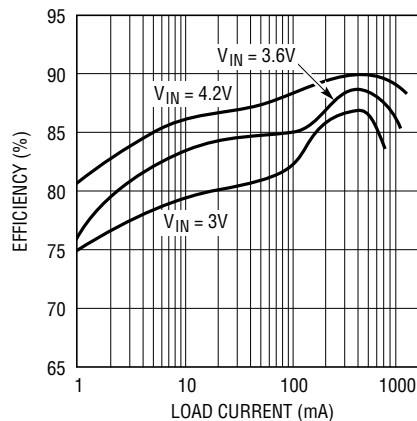

1308 F01a

## ABSOLUTE MAXIMUM RATINGS

$V_{IN}$ , $\overline{SHDN}$ , LBO Voltage .....	10V
SW Voltage .....	30V
FB Voltage .....	$V_{IN} + 1V$
$V_C$ Voltage .....	2V
LBI Voltage .....	$0V \leq V_{LBI} \leq 1V$
Current into FB Pin .....	$\pm 1mA$
Junction Temperature .....	125°C
Operating Temperature Range	
Commercial (Note 1) .....	-20°C to 70°C
Industrial .....	-40°C to 85°C
Storage Temperature Range .....	-65°C to 150°C
Lead Temperature (Soldering, 10 sec) .....	300°C

## PACKAGE/ORDER INFORMATION

<p>TOP VIEW</p> <p>S8 PACKAGE 8-LEAD PLASTIC SO</p> <p><math>T_{jMAX} = 125^{\circ}C</math>, <math>\theta_{JA} = 80^{\circ}C/W</math></p>	ORDER PART NUMBER
	LT1308CS8 LT1308IS8
	S8 PART MARKING
	1308 1308I

Consult factory for Military grade parts.

## ELECTRICAL CHARACTERISTICS

Commercial Grade 0°C to 70°C.  $V_{IN} = 1.1V$ ,  $V_{\overline{SHDN}} = V_{IN}$ ,  $T_A = 25^{\circ}C$ , unless otherwise noted.

SYMBOL	PARAMETER	CONDITIONS	MIN	TYP	MAX	UNITS
$I_Q$	Quiescent Current	Not Switching $V_{\overline{SHDN}} = 0V$	●	80	160	$\mu A$
			●	1	3	$\mu A$
$V_{FB}$	Feedback Voltage		● 1.20	1.22	1.24	V
$I_B$	FB Pin Bias Current (Note 2)	$V_{FB} = V_{REF}$	●	27	80	nA
	Reference Line Regulation	$1.1V \leq V_{IN} \leq 2V$ (25°C, 0°C) $1.1V \leq V_{IN} \leq 2V$ (70°C) $2V \leq V_{IN} \leq 6V$	●	0.6 0.3	1.1 0.8	%/V %/V
	Minimum Input Voltage			0.92	1	V
	Input Voltage Range		● 1		6	V
$g_m$	Error Amp Transconductance	$\Delta I = 5\mu A$		40		$\mu mhos$
$A_V$	Error Amp Voltage Gain	25°C, 0°C 70°C		100		V/V
				80		V/V
$f_{OSC}$	Switching Frequency		● 500	600	700	kHz
	Maximum Duty Cycle		● 80	88	95	%
	Switch Current Limit (Note 3)	DC = 40% DC = 80%	●	2.0	2.5	A
			●	1.6	2	A
	Switch $V_{CESAT}$	$I_{SW} = 2A$ (25°C, 0°C) $I_{SW} = 2A$ (70°C)		300	350	mV
				330	400	mV
	Burst Mode Operation Switch Current Limit	$L = 3.3\mu H$ , $V_{OUT} = 3.3V$ , $V_{IN} = 1.2V$		200		mA
	Shutdown Pin Current	$V_{\overline{SHDN}} = 1.1V$ $V_{\overline{SHDN}} = 6V$ $V_{\overline{SHDN}} = 0V$	●	2.5	4.0	$\mu A$
			●	13	26	$\mu A$
			●	-1.5	-2.5	$\mu A$
	LBI Threshold Voltage		● 180	200	220	mV
	LBO Output Low	$I_{SINK} = 10\mu A$	●	0.1	0.25	V
	LBO Leakage Current	$V_{LBI} = 250mV$ , $V_{LBO} = 5V$	●	0.01	0.1	$\mu A$
	LBI Input Bias Current (Note 4)	$V_{LBI} = 150mV$	●	5	30	nA

## ELECTRICAL CHARACTERISTICS

Commercial Grade 0°C to 70°C.  $V_{IN} = 1.1V$ ,  $V_{SHDN} = V_{IN}$ ,  $T_A = 25^\circ C$  unless otherwise noted.

SYMBOL	PARAMETER	CONDITIONS	MIN	TYP	MAX	UNITS
	Low-Battery Detector Gain	1M $\Omega$ Load (25°C, 0°C) 1M $\Omega$ Load (70°C)	1000 500	3000		V/V V/V
	Switch Leakage Current	$V_{SW} = 5V$	●	0.01	10	$\mu A$
	Reverse Battery Current	(Note 5)		750		mA

Commercial Grade  $T_A = -20^\circ C$ ,  $V_{IN} = 1.1V$ ,  $V_{SHDN} = V_{IN}$ , unless otherwise noted (Note 1).

SYMBOL	PARAMETER	CONDITIONS	MIN	TYP	MAX	UNITS
$I_Q$	Quiescent Current	$V_{FB} = 1.3V$ , Not Switching $V_{SHDN} = 0V$		80 1	160 3	$\mu A$ $\mu A$
$V_{FB}$	Feedback Voltage		1.195	1.22	1.245	V
$g_m$	Error Amp Transconductance	$\Delta I = 5\mu A$		35		$\mu mhos$
$A_V$	Error Amp Voltage Gain			100		V/V
$f_{OSC}$	Switching Frequency		500	600	750	kHz
	Maximum Duty Cycle			88		%
	Switch $V_{CESAT}$	$I_{SW} = 2A$ , $V_{IN} = 1.2V$		300	350	mV
	Shutdown Pin Current	$V_{SHDN} = V_{IN}$ $V_{SHDN} = 0V$		2.5 -1.5	4.0 -2.5	$\mu A$ $\mu A$
	LBI Threshold Voltage		180	200	220	mV

Industrial Grade  $-40^\circ C$  to  $85^\circ C$ .  $V_{IN} = 1.2V$ ,  $V_{SHDN} = V_{IN}$ ,  $T_A = 25^\circ C$ , unless otherwise noted.

SYMBOL	PARAMETER	CONDITIONS	MIN	TYP	MAX	UNITS	
$I_Q$	Quiescent Current	Not Switching $V_{SHDN} = 0V$	● ●	80 1	160 3	$\mu A$ $\mu A$	
$V_{FB}$	Feedback Voltage		●	1.195	1.22	1.245	V
$I_B$	FB Pin Bias Current (Note 2)	$V_{FB} = V_{REF}$	●	27	80	nA	
	Reference Line Regulation	$1.1V \leq V_{IN} \leq 2V$ ( $-40^\circ C$ ) $1.1V \leq V_{IN} \leq 2V$ ( $85^\circ C$ ) $2V \leq V_{IN} \leq 6V$	●	0.6 0.3	1.1 0.8	%/V %/V %/V	
	Minimum Input Voltage ( $-40^\circ C$ )				1.2	V	
	Input Voltage Range		●	1.2	6	V	
$g_m$	Error Amp Transconductance	$\Delta I = 5\mu A$		40		$\mu mhos$	
$A_V$	Error Amp Voltage Gain	$-40^\circ C$ $85^\circ C$		100 80		V/V V/V	
$f_{OSC}$	Switching Frequency	$V_{IN} = 1.3V$ ( $-40^\circ C$ ) $V_{IN} = 1.3V$ ( $85^\circ C$ )		500 500	600 600	750 750	kHz kHz
	Maximum Duty Cycle	$-40^\circ C$ $85^\circ C$		80 75	88 95	% %	
	Switch Current Limit (Note 3)	DC = 40% DC = 80%	●	2.0 1.6	2.5 2	A A	
	Switch $V_{CESAT}$	$I_{SW} = 2A$ ( $-40^\circ C$ ) $I_{SW} = 2A$ ( $85^\circ C$ )		300 330	350 400	mV mV	
	Burst Mode Operation Switch Current Limit	$L = 3.3\mu H$ , $V_{OUT} = 3.3V$		200		mA	

## ELECTRICAL CHARACTERISTICS

Industrial Grade  $-40^{\circ}\text{C}$  to  $85^{\circ}\text{C}$ .  $V_{\text{IN}} = 1.2\text{V}$ ,  $V_{\text{SHDN}} = V_{\text{IN}}$ ,  $T_{\text{A}} = 25^{\circ}\text{C}$ , unless otherwise noted.

SYMBOL	PARAMETER	CONDITIONS	MIN	TYP	MAX	UNITS	
	Shutdown Pin Current	$V_{\text{SHDN}} = 1.2\text{V}$	●	2.5	4.0	$\mu\text{A}$	
		$V_{\text{SHDN}} = 6\text{V}$	●	13	26	$\mu\text{A}$	
		$V_{\text{SHDN}} = 0\text{V}$	●	-1.5	-2.5	$\mu\text{A}$	
	LBI Threshold Voltage		●	180	200	220	mV
	LBO Output Low	$I_{\text{SINK}} = 10\mu\text{A}$	●	0.1	0.25	V	
	LBO Leakage Current	$V_{\text{LBI}} = 250\text{mV}$ , $V_{\text{LBO}} = 5\text{V}$	●	0.01	0.1	$\mu\text{A}$	
	LBI Input Bias Current (Note 4)	$V_{\text{LBI}} = 150\text{mV}$	●	5	30	nA	
	Low-Battery Detector Gain	1M $\Omega$ Load ( $-40^{\circ}\text{C}$ )		1000	3000	V/V	
		1M $\Omega$ Load ( $85^{\circ}\text{C}$ )		300		V/V	
	Switch Leakage Current	$V_{\text{SW}} = 5\text{V}$	●	0.01	10	$\mu\text{A}$	

The ● denotes specifications which apply over the full operating temperature range.

**Note 1:** C grade device specifications are guaranteed over the  $0^{\circ}\text{C}$  to  $70^{\circ}\text{C}$  temperature range. In addition, C grade device specifications are assured over the  $-40^{\circ}\text{C}$  to  $85^{\circ}\text{C}$  temperature range by design or correlation, but are not production tested.

**Note 2:** Bias current flows into FB pin.

**Note 3:** Switch current limit guaranteed by design and/or correlation to static tests. Duty cycle affects current limit due to ramp generator (see Block Diagram).

**Note 4:** Bias current flows out of LBI pin.

**Note 5:** The LT1308 will withstand continuous application of 1.6V applied to GND pin while  $V_{\text{IN}}$  and SW are grounded.

## TYPICAL PERFORMANCE CHARACTERISTICS

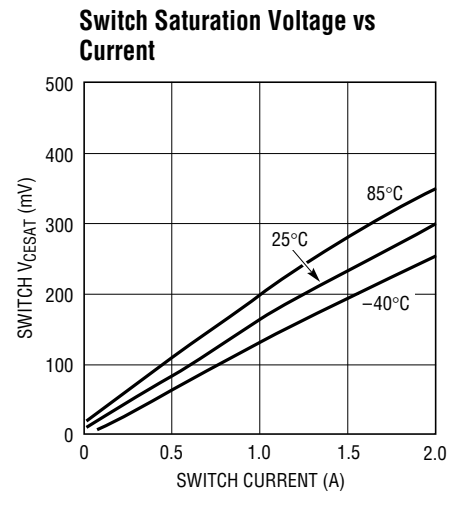
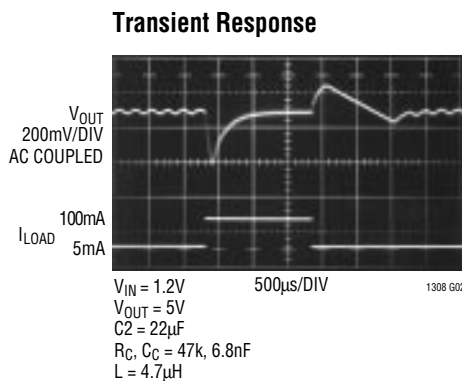
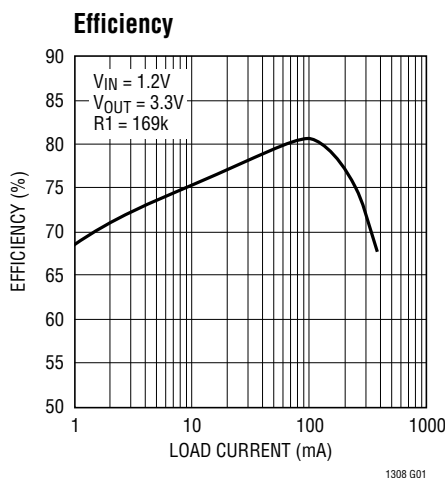

## PIN FUNCTIONS

**$V_{\text{C}}$  (Pin 1):** Compensation Pin for Error Amplifier. Connect a series RC from this pin to ground. Typical values are 47k $\Omega$  and 22nF. Minimize trace area at  $V_{\text{C}}$ .

**FB (Pin 2):** Feedback Pin. Reference voltage is 1.22V. Connect resistive divider tap here. Minimize trace area at FB. Set  $V_{\text{OUT}}$  according to:  $V_{\text{OUT}} = 1.22\text{V}(1 + R_1/R_2)$ .

**SHDN (Pin 3):** Shutdown. Ground this pin to turn off switcher. Must be tied to  $V_{\text{IN}}$  (or higher voltage) to enable switcher. Do not float the SHDN pin.

**GND (Pin 4):** Ground. Connect directly to local ground plane. Ground plane should enclose all components associated with the LT1308.

## PIN FUNCTIONS

**SW (Pin 5):** Switch Pin. Connect inductor/diode here. Minimize trace area at this pin to keep EMI down.

**V<sub>IN</sub> (Pin 6):** Supply Pin. Must have local bypass capacitor right at the pin, connected directly to ground.

**LBI (Pin 7):** Low-Battery Detector Input. 200mV reference. Voltage on LBI must stay between ground and

700mV. Low-battery detector does not function with SHDN pin grounded. If not used, float LBI pin.

**LBO (Pin 8):** Low-Battery Detector Output. Open collector, can sink 10μA. A 1MΩ pullup is recommended. LBO is high impedance when SHDN is grounded.

## BLOCK DIAGRAM

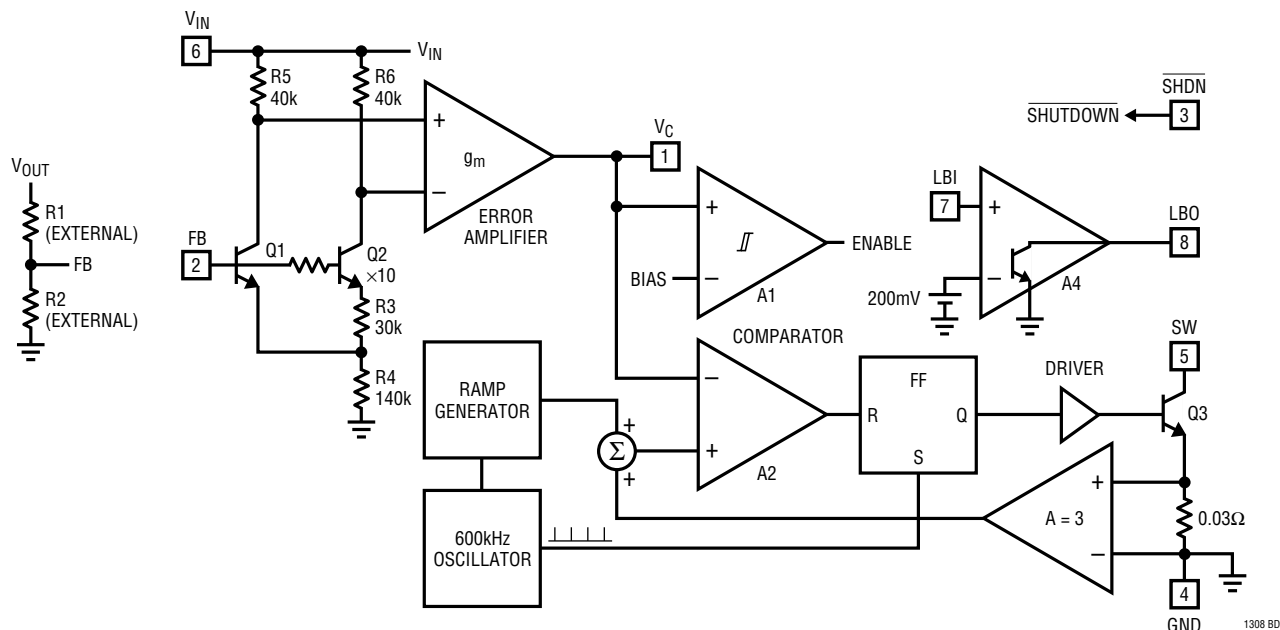

## APPLICATIONS INFORMATION

### LAYOUT HINTS

The LT1308 switches current at high speed, mandating careful attention to layout for proper performance. *You will not get advertised performance with careless layouts.* Figure 2 shows recommended component placement. Follow this closely in your PCB layout. Note the direct path of the switching loops. Input capacitor C<sub>IN</sub> *must* be placed close (< 5mm) to the IC package. As little as 10mm of wire or PCB trace from C<sub>IN</sub> to V<sub>IN</sub> will cause problems such as inability to regulate or oscillation. A 10μF ceramic bypass capacitor is the only input capacitance required *provided the battery has a low inductance path to the circuit.* The battery itself provides the bulk capacitance the device requires for proper operation. If the battery is located some

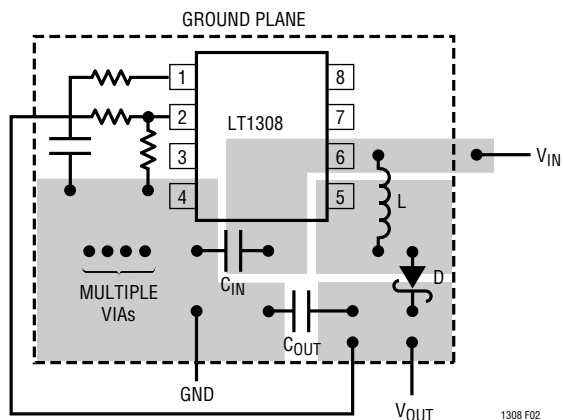

**Figure 2. Recommended Component Placement.** Traces Carrying High Current Are Direct. Trace Area at FB Pin and V<sub>C</sub> Pin is Kept Low. Lead Length to Battery Should Be Kept Short. Ground Plane Should Be Placed Under All Components

## APPLICATIONS INFORMATION

distance from the circuit, an additional input capacitor may be required. A 220µF aluminum electrolytic unit works well in these cases. This capacitor need not have low ESR.

### OPERATION FROM A LABORATORY POWER SUPPLY

If a lab supply is used, the leads used to connect the circuit to the supply can have significant inductance at the LT1308's switching frequency. As in the previous situation, an electrolytic capacitor may be required at the circuit in order to reduce the AC impedance of the input sufficiently. An alternative solution is to attach the circuit directly to the power supply at the supply terminals, without the use of leads. The power supply's output capacitance will then provide the bulk capacitance the LT1308 circuit requires.

### SHUTDOWN PIN

The LT1308 has a shutdown pin ( $\overline{\text{SHDN}}$ ) that must be grounded to shut the device down or tied to a voltage equal or greater than  $V_{\text{IN}}$  to operate. The shutdown circuit is shown in Figure 3.

Note that allowing  $\overline{\text{SHDN}}$  to float turns on both the start-up current (Q2) and the shutdown current (Q3) for  $V_{\text{IN}} > 2V_{\text{BE}}$ . The LT1308 doesn't know what to do in this situation and behaves erratically.  $\overline{\text{SHDN}}$  voltage above  $V_{\text{IN}}$  is allowed. This merely reverse-biases Q3's base emitter junction, a benign condition.

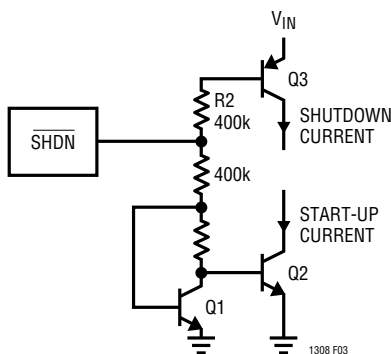

Figure 3. Shutdown Circuit

### LOW-BATTERY DETECTOR

The LT1308's low-battery detector is a simple PNP input gain stage with an open collector NPN output. The nega-

tive input of the gain stage is tied internally to a 200mV reference. The positive input is the LBI pin. Arrangement as a low-battery detector is straightforward. Figure 4 details hookup. R1 and R2 need only be low enough in value so that the bias current of the LBI pin doesn't cause large errors. For R2, 100k is adequate. The 200mV reference can also be accessed as shown in Figure 5.

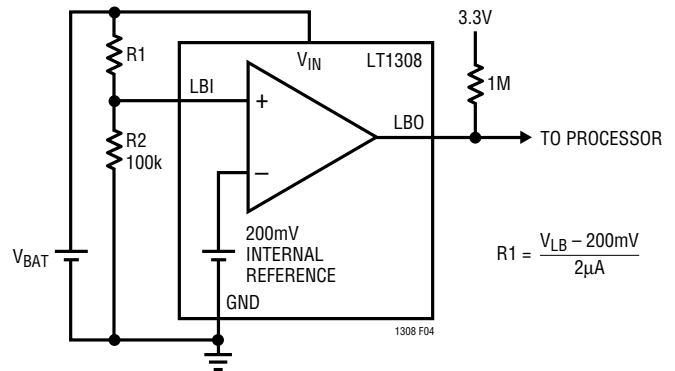

Figure 4. Setting Low-Battery Detector Trip Point

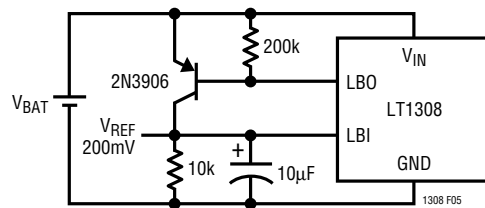

Figure 5. Accessing 200mV Reference

### GSM PHONES

The LT1308 is suitable for converting a single Li-Ion cell to 5V for powering GSM RF power stages. Figure 6 details a Li-Ion to 5V converter circuit using frequency compensation optimized for a typical GSM pulsed load. Figure 7 details transient response of Figure 6's circuit with a 100mA to 1A pulsed load. A slower time sweep is used to show several transmit pulses in Figure 8. At a  $V_{\text{IN}}$  of 2.7V, additional output capacitance is recommended to help minimize  $V_{\text{OUT}}$  droop. Figure 9 shows  $V_{\text{OUT}}$  with an input voltage of 2.7V. Figure 10 expands the horizontal sweep speed to 500µs/division to show detail of one transmit pulse.

# APPLICATIONS INFORMATION

## DECT PHONES

The DECT standard specifies a transmit pulse 416 $\mu$ s in duration. The LT1308 is capable of delivering a 400mA pulse load from a 1.2V input with output capacitance of 100 $\mu$ F. Figure 11 depicts  $V_{OUT}$  transient response of Figure 6's circuit, configured for a 3.3V output by changing resistor R1 to 169k. Figure 12 shows detail of one transmit pulse at a higher sweep speed.

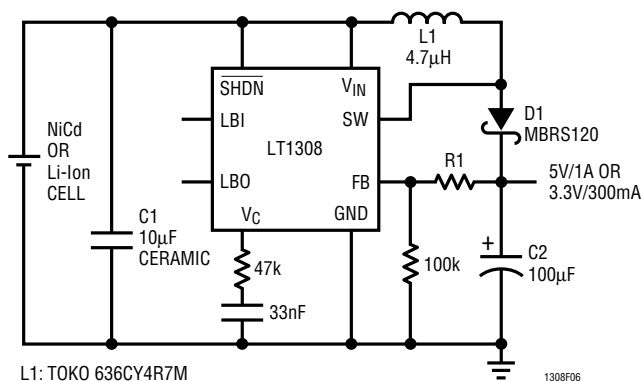

L1: TOKO 636CY4R7M  
 COILTRONICS CTX5-1  
 FOR  $V_{OUT} = 5V$ : R1 = 309k  
 FOR  $V_{OUT} = 3.3V$ : R1 = 169k

Figure 6. DC/DC Converter for GSM/DECT Application

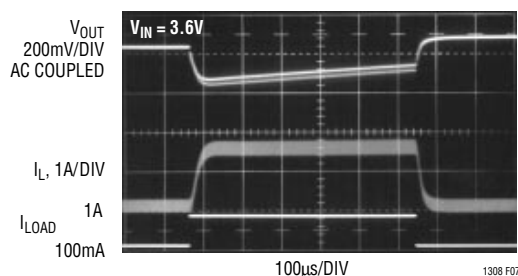

Figure 7. GSM Load Transient Response. 100mA to 1A Transient Response for Figure 6's Circuit. Pulse Width = 577 $\mu$ s

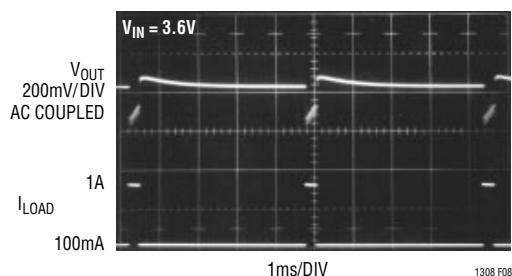

Figure 8. GSM Load Transient Response. Slower Sweep Speed (1ms/DIV) Shows  $V_{OUT}$  over Several Transmit Pulses

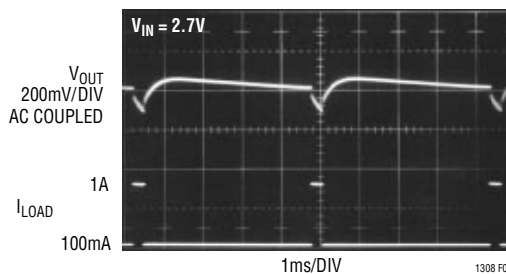

Figure 9. GSM Load Transient Response. At Low  $V_{IN}$ , Large Output Capacitor (2200 $\mu$ F) Serves to Hold up  $V_{OUT}$

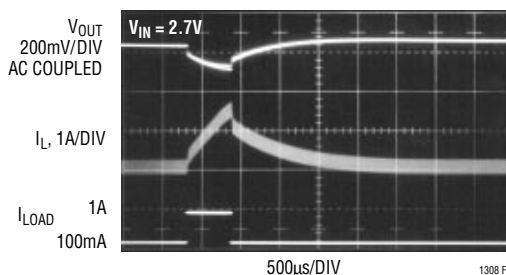

Figure 10. GSM Load Transient Response. Faster Sweep Speed (500 $\mu$ s/DIV) Details  $V_{OUT}$  and Inductor Current of One Transmit Pulse

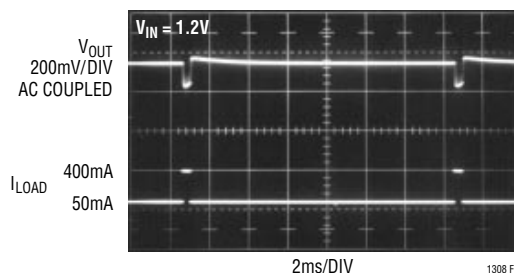

Figure 11. DECT Load Transient Response. With a Single NiCd Cell the LT1308 Provides 3.3V with 400mA Pulsed Load. Pulse Width = 416 $\mu$ s

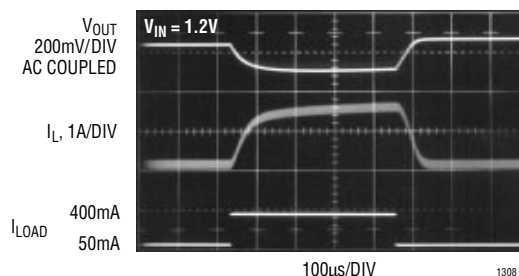
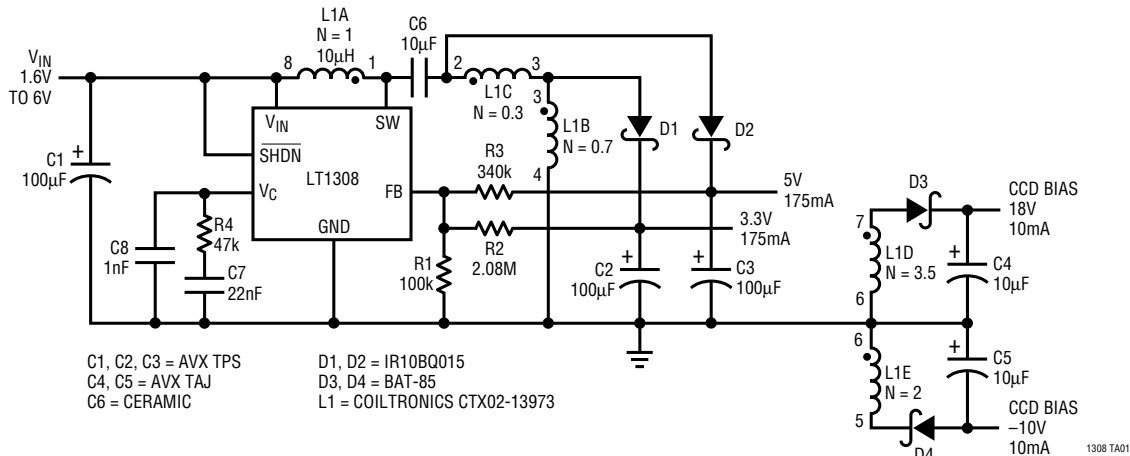

Figure 12. DECT Load Transient Response. Faster Sweep Speed (100 $\mu$ s/DIV) Details  $V_{OUT}$  and Inductor Current of Single DECT Transmit Pulse

**TYPICAL APPLICATION**

**Digital Camera Power Supply**  
**2-4 Cell to 3.3V/175mA, 5V/175mA, 18V/10mA, -10V/10mA**



**PACKAGE DESCRIPTION** Dimensions in inches (millimeters) unless otherwise noted.

**S8 Package**  
**8-Lead Plastic Small Outline (Narrow 0.150)**  
 (LTC DWG # 05-08-1610)

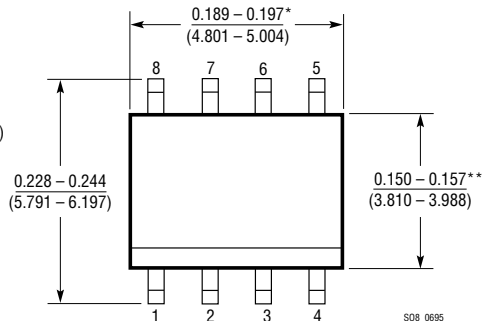
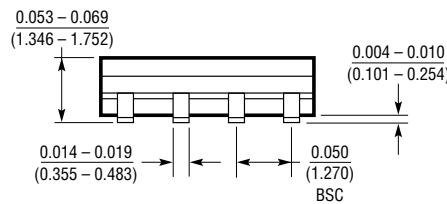
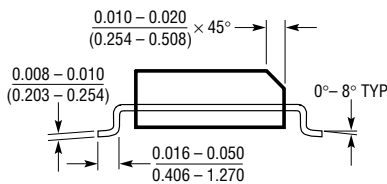

\*DIMENSION DOES NOT INCLUDE MOLD FLASH. MOLD FLASH SHALL NOT EXCEED 0.006" (0.152mm) PER SIDE  
 \*\*DIMENSION DOES NOT INCLUDE INTERLEAD FLASH. INTERLEAD FLASH SHALL NOT EXCEED 0.010" (0.254mm) PER SIDE

**RELATED PARTS**

PART NUMBER	DESCRIPTION	COMMENTS
LTC®1163	Triple High Side Driver for 2-Cell Inputs	1.8V Minimum Input, Drives N-Channel MOSFETs
LTC1174	Micropower Step-Down DC/DC Converter	94% Efficiency, 130µA I <sub>Q</sub> , 9V to 5V at 300mA
LT1302	High Output Current Micropower DC/DC Converter	5V/600mA from 2V, 2A Internal Switch, 200µA I <sub>Q</sub>
LT1304	2-Cell Micropower DC/DC Converter	Low-Battery Detector Active in Shutdown, 5V at 200mA for 2 Cells
LT1307	Single Cell Micropower 600kHz PWM DC/DC Converter	3.3V at 75mA from 1 Cell, MSOP Package
LT1316	Micropower DC/DC Converter with Programmable Peak Current Limit	Works with High Source Impedance, 1.5V Minimum Input, Low-Battery Detector Active in Shutdown, 33µA I <sub>Q</sub> , MSOP Package
LTC1440/1/2	Ultralow Power Single/Dual Comparators with Reference	2.8µA I <sub>Q</sub> , Adjustable Hysteresis
LTC1516	2-Cell to 5V Regulated Charge Pump	12µA I <sub>Q</sub> , No Inductors, 5V at 50mA from 3V Input
LT1521	Micropower Low Dropout Linear Regulator	500mV Dropout, 300mA Current, 12µA I <sub>Q</sub>

## Looking for pricing, stock, or lifecycle information?

Click below to explore more details on WIN SOURCE:

 [View LT1308IS8#PBF on WIN SOURCE](#)

 [Linear Technology](#) Information

## Optimize Your Supply Chain with WIN SOURCE Solutions

-  Global Sourcing Solution
-  Obsolete Management
-  Cost Control Management
-  Shortage Management
-  Alternative Solution
-  Excess Inventory Management