



**THE DATASHEET OF
LT1612ES8#PBF**



Synchronous, Step-Down 800kHz PWM DC/DC Converter

FEATURES

- Operates from Input Voltage As Low As 2V
- Internal 0.7A Synchronous Switches
- Uses Ceramic Input and Output Capacitors
- 620mV Reference Voltage
- 800kHz Fixed Frequency Switching
- Programmable Burst Mode Operation
- Low Quiescent Current: 160 μ A
- 8-Lead MSOP or SO Package

APPLICATIONS

- Portable Devices
- Lithium-Ion Step-Down Converters
- 5V to 3.3V Conversion
- 2-Cell Alkaline Step-Down Converters

DESCRIPTION

The LT[®]1612 is an 800kHz, synchronous step-down DC/DC converter that operates from an input voltage as low as 2V. Internal 0.45 Ω switches deliver output currents up to 500mA, and the 800kHz switching frequency allows the use of small, low value ceramic input and output capacitors. Input voltage ranges from 5.5V down to 2V and output voltage can be set as low as the 620mV reference. The device features Burst Mode[™] operation, keeping efficiency high at light loads. Burst Mode operation can be defeated by pulling the $\overline{\text{MODE}}$ pin high, enabling constant switching throughout the load range for low noise.

No-load quiescent current is 160 μ A and shutdown current is less than 1 μ A. The device is available in 8-lead SO and MSOP packages.

LT, LTC and LT are registered trademarks of Linear Technology Corporation. Burst Mode is a trademark of Linear Technology Corporation.

TYPICAL APPLICATION

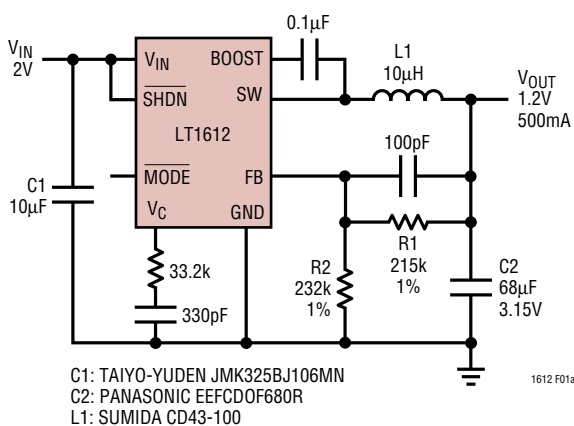
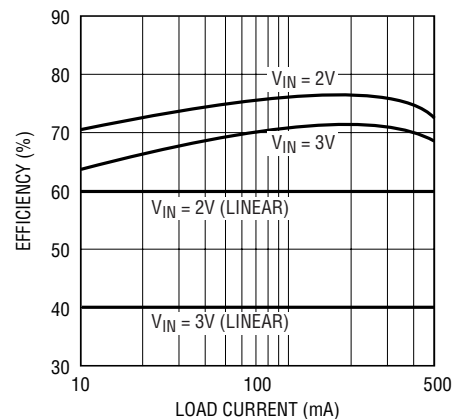

Figure 1. 2V to 1.2V Converter

Efficiency for LT1612 vs Linear Regulator
 $V_{\text{OUT}} = 1.2\text{V}$



LT1612

ABSOLUTE MAXIMUM RATINGS (Note 1)

Supply Voltage (V_{IN})	5.5V	BOOST Pin Voltage	$V_{IN} + 5.5V$
SW Pin Voltage	5.5V	Junction Temperature	125°C
FB Pin Voltage	$V_{IN} + 0.3V$	Operating Temperature Range (Note 2)	-40°C to 85°C
V_C Pin Voltage	2V	Storage Temperature Range	-65°C to 150°C
\overline{SHDN} Pin Voltage	5.5V	Lead Temperature (Soldering, 10 sec)	300°C
\overline{MODE} Pin Voltage	5.5V		

PACKAGE/ORDER INFORMATION

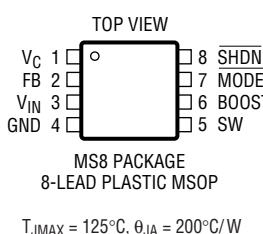
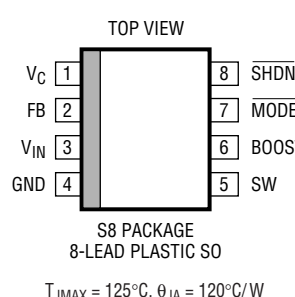
 <p>MS8 PACKAGE 8-LEAD PLASTIC MSOP</p> <p>$T_{JMAX} = 125^{\circ}C, \theta_{JA} = 200^{\circ}C/W$</p>	ORDER PART NUMBER	 <p>S8 PACKAGE 8-LEAD PLASTIC SO</p> <p>$T_{JMAX} = 125^{\circ}C, \theta_{JA} = 120^{\circ}C/W$</p>	ORDER PART NUMBER
	LT1612EMS8		LT1612ES8
	MS8 PART MARKING		S8 PART MARKING
	LTMS		1612

Consult factory for parts specified with wider operating temperature ranges.

ELECTRICAL CHARACTERISTICS

The ● denotes specifications which apply over the full operating temperature range, otherwise specifications are $T_A = 25^{\circ}C, V_{IN} = V_{\overline{SHDN}} = 3V$

SYMBOL	PARAMETER	CONDITIONS	MIN	TYP	MAX	UNITS
I_Q	Quiescent Current	$\overline{MODE} = 5V$	●	1	2	mA
		$\overline{MODE} = 0V$, Not Switching	●	160	220	μA
		$\overline{SHDN} = 0V$	●		1	μA
V_{FB}	FB Voltage	●	0.605	0.62	0.635	V
		●	0.60	0.62	0.635	V
	FB Line Regulation	●		0.02	0.15	%/V
	FB Pin Bias Current (Note 3)	●		7	50	nA
g_m	Error Amplifier Transconductance			250		$\mu mhos$
	Min Input Voltage		2			V
	Max Input Voltage				5.5	V
f_{OSC}	Oscillator Frequency	●	700	800	900	kHz
			550		1100	kHz
	f_{OSC} Line Regulation			1		%/V
	Maximum Duty Cycle		85	90		%
●		80				%
	Shutdown Threshold	●	2			V
●		Minimum Voltage for Active Maximum Voltage for Shutdown			0.2	

sn1612 1612fs

ELECTRICAL CHARACTERISTICS The ● denotes specifications which apply over the full operating temperature range, otherwise specifications are $T_A = 25^\circ\text{C}$, $V_{IN} = V_{SHDN} = 3\text{V}$

SYMBOL	PARAMETER	CONDITIONS	MIN	TYP	MAX	UNITS	
	SHDN Pin Current	SHDN = 2V	●	10	15	μA	
		SHDN = 5V	●	30	45	μA	
	BOOST Pin Current	BOOST = $V_{IN} + 2\text{V}$		4		mA	
	Switch Current Limit (Note 4)	Duty Cycle = 0%	MODE = 0V	600	710	900	mA
			MODE = 5V	550	650	900	mA
	Burst Mode Operation Current Limit	MODE = 0V		180		mA	
	Switch Voltage Drop	$I_{SW} = 500\text{mA}$		200	280	mV	
	Rectifier Voltage Drop	$I_{RECT} = 500\text{mA}$		300	400	mV	
	SW Pin Leakage	$V_{SW} = 5\text{V}$, $V_{SHDN} = 0\text{V}$	●		1	μA	

Note 1: Absolute Maximum Ratings are those values beyond which the life of a device may be impaired.

Note 2: The LT1612E is guaranteed to meet performance specifications from 0°C to 70°C . Specifications over the -40°C to 85°C operating

temperature range are assured by design, characterization and correlation with statistical process controls.

Note 3: Bias current flows out of the FB pin.

Note 4: Duty cycle affects current limit due to slope compensation.

TYPICAL PERFORMANCE CHARACTERISTICS

FB Voltage vs Temperature

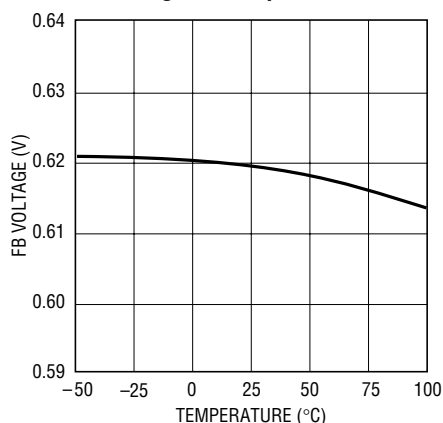

1612 • G01

Quiescent Current vs Temperature

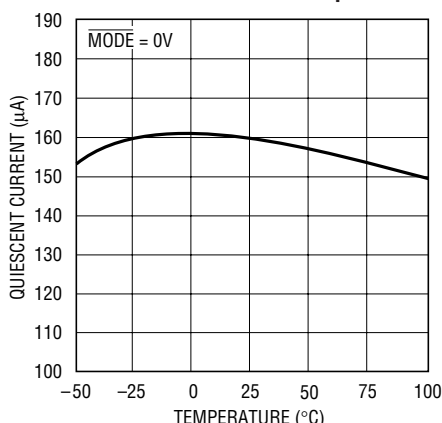

1612 • G02

FB Pin Bias Current

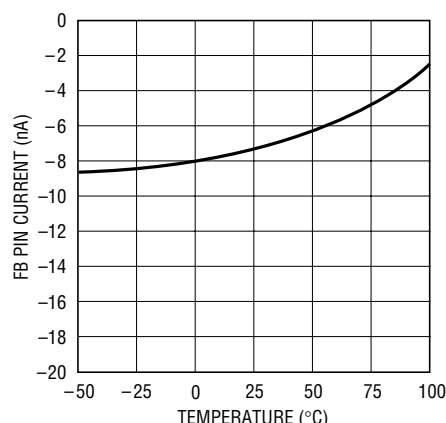

1612 • G03

TYPICAL PERFORMANCE CHARACTERISTICS

SHDN Pin Bias Current

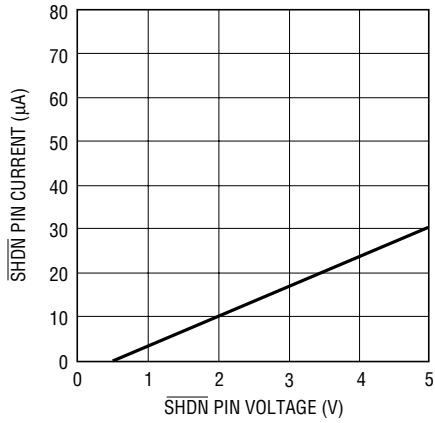

1612 • G04

Switch Current Limit vs Temperature

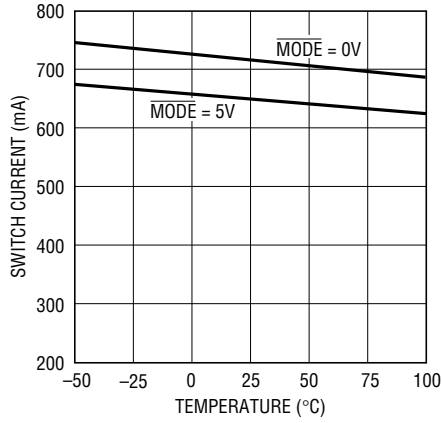

1612 • G05

Oscillator Frequency vs Temperature

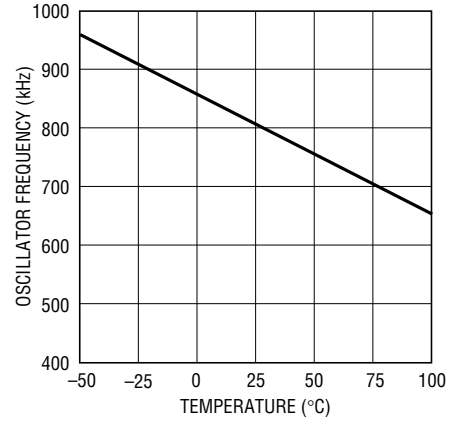

1612 • G06

Maximum Duty Cycle vs Temperature

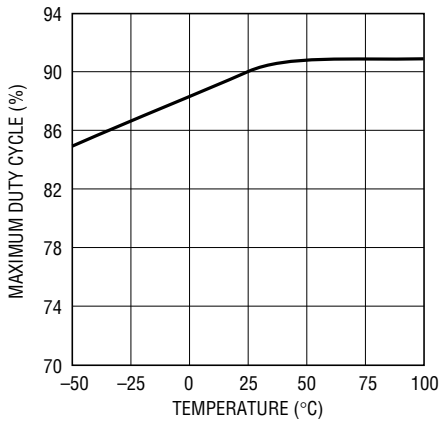

1612 • G07

Switch Voltage Drop

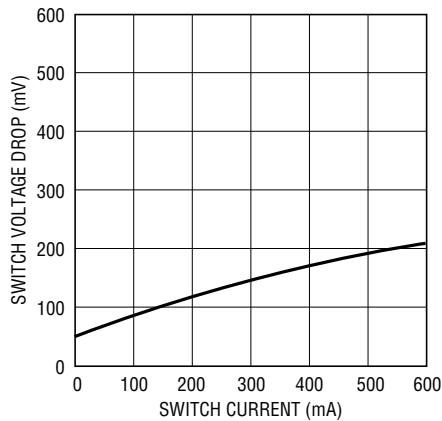

1612 • G08

Rectifier Voltage Drop

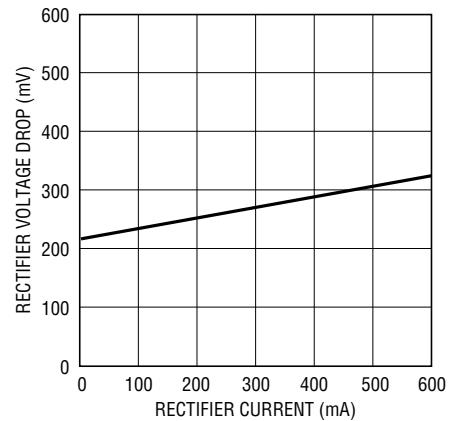

1612 • G09

PIN FUNCTIONS

V_C (Pin 1): Compensation Pin. This is the current sink/source output of the error amplifier. By connecting an RC network from this pin to ground, frequency response can be tuned for a wide range of circuit configurations. The voltage at this pin also sets the current limit, and if grounded, the switch will remain in the OFF state.

FB (Pin 2): Feedback Pin. This pin is the negative input to the error amplifier. Connect the resistor divider tap to this point which sets V_{OUT} according to:

$$V_{OUT} = 0.62V (1 + R1/R2)$$

V_{IN} (Pin 3): Supply Pin. Bypass capacitor C1 must be right next to this pin.

GND (Pin 4): Ground Pin. Connect directly to local ground plane.

SW (Pin 5): Switch Pin. Connect inductor and boost capacitor here. Minimize trace area at this pin to keep EMI down.

BOOST (Pin 6): This is the supply pin for the switch driver and must be above V_{IN} by 1.5V for proper switch operation. Connect the boost capacitor to this pin.

MODE (Pin 7): Burst Mode Operation Disable Pin. For continuous switching operation (low noise), pull this pin above 2V. For Burst Mode operation which gives better light load efficiency, tie to ground. Output ripple voltage in Burst Mode operation is typically 30mV_{P-P}. See applications section for more information about this function.

SHDN (Pin 8): Shutdown Pin. Pull this pin low for shutdown mode. Tie to a voltage between 2V and 5.5V for normal operation.

BLOCK DIAGRAM

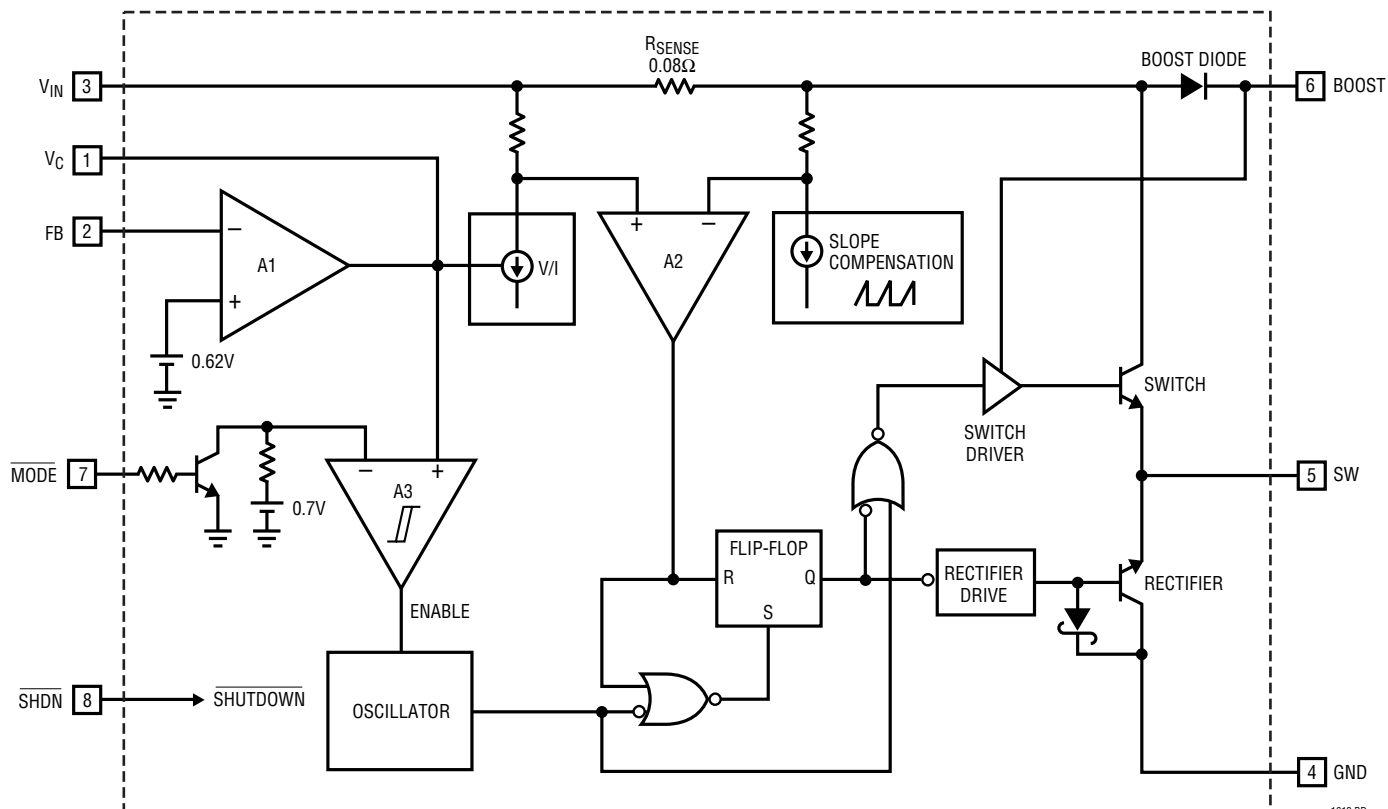

1612 BD

OPERATION

The LT1612 employs fixed frequency, current mode control. This type of control uses two feedback loops. The main control loop sets output voltage and operates as follows: A load step causes V_{OUT} and the FB voltage to be perturbed slightly. The error amplifier responds to this change in FB by driving the V_C pin either higher or lower. Because switch current is proportional to the V_C pin voltage, this change causes the switch current to be adjusted until V_{OUT} is once again satisfied. Loop compensation is taken care of by an RC network from the V_C pin to ground.

Inside this main loop is another that sets current limit on a cycle-by-cycle basis. This loop utilizes current comparator A2 to control peak current. The oscillator runs at 800kHz and issues a set pulse to the flip-flop at the beginning of each cycle, turning the switch on. With the switch now in the ON state the SW pin is effectively connected to V_{IN} . Current ramps up in the inductor linearly at a rate of $(V_{IN} - V_{OUT})/L$. Switch current is set by the V_C pin voltage and when the voltage across R_{SENSE} trips the current comparator, a reset pulse will be generated and the switch will be turned off. Since the inductor is now loaded up with current, the SW pin will fly low and trigger the rectifier to turn on. Current will flow through the rectifier decreasing at a rate of V_{OUT}/L until the oscillator issues a new set pulse, causing the cycle to repeat.

If the load is light and V_C decreases below A3's trip point, the device will enter the Burst Mode operation region (the \overline{MODE} pin must be at ground or floating). In this state the oscillator and all other circuitry except the reference and comparator A3 are switched on and off at low frequency. This mode of operation increases efficiency at light loads but introduces low frequency voltage ripple at the output. For continuous switching and no low frequency output voltage ripple, pull the \overline{MODE} pin high. This will disable comparator A3 which forces the oscillator to run continuously.

Layout Hints

The LT1612 switches current at high speed, mandating careful attention to layout for proper performance. *You will not get advertised performance with careless layout.* Figure 2 shows recommended component placement for a buck (step-down) converter. Follow this closely in your PC layout. Note the direct path of the switching loops. Input capacitor C1 must be placed close ($< 5\text{mm}$) to the IC package. As little as 10mm of wire or PC trace from C_{IN} to V_{IN} will cause problems such as inability to regulate or oscillation.

The ground terminal of input capacitor C1 should tie close to Pin 4 of the LT1612. Doing this reduces di/dt in the ground copper which keeps high frequency spikes to a minimum. The DC/DC converter ground should tie to the PC board ground plane at one place only, to avoid introducing di/dt in the ground plane.

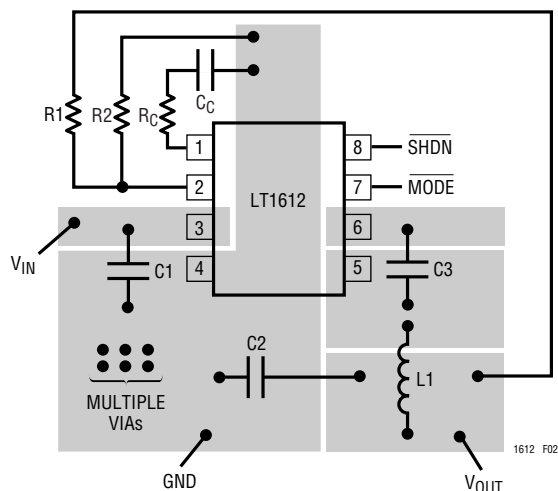

Figure 2. Recommended Component Placement. Traces Carrying High Current are Direct. Trace Area at FB Pin and V_C Pin Is Kept Low. Lead Length to Battery Should Be Kept Short

OPERATION

Burst Mode Operation Defeat

To maintain high efficiency at light loads, the LT1612 will automatically shift into Burst Mode operation ($\overline{\text{MODE}} = 0\text{V}$ or floating). In this mode of operation the oscillator and switch drive circuitry is alternately turned on and off, reducing quiescent current to $160\mu\text{A}$. This reduces power

consumption but also adds low frequency voltage ripple to the output. Figure 3 shows switching waveforms for a 5V to 3.3V converter running in Burst Mode operation. Output voltage ripple is approximately $20\text{mV}_{\text{P-P}}$. If the $\overline{\text{MODE}}$ pin is pulled high, Burst Mode operation will be inhibited and the oscillator runs continuously with no low frequency ripple at the output. See Figures 4 and 5.

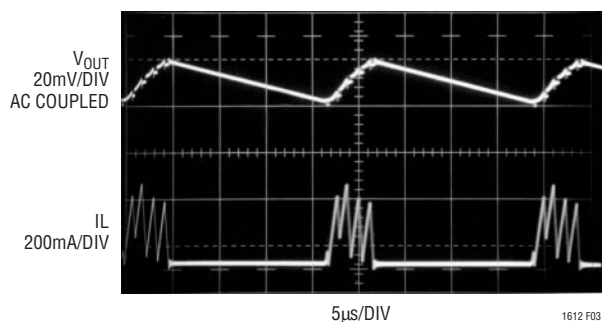

Figure 3. Output Voltage Ripple is $20\text{mV}_{\text{P-P}}$ for the Circuit of Figure 1

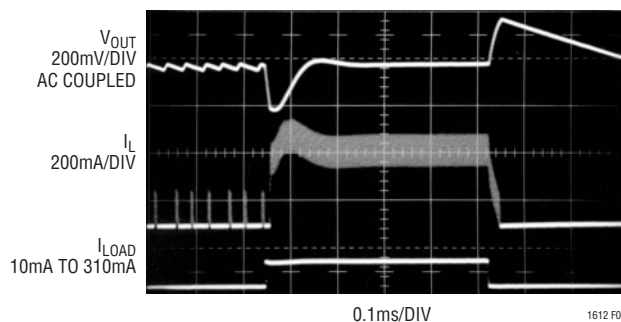

Figure 4. Transient Response for the Circuit of Figure 1 with the $\overline{\text{MODE}}$ Pin Tied to Ground or Floating

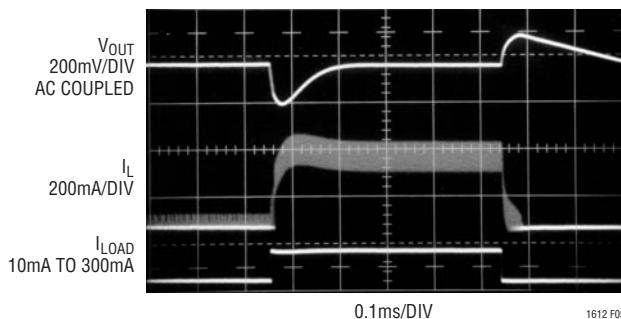
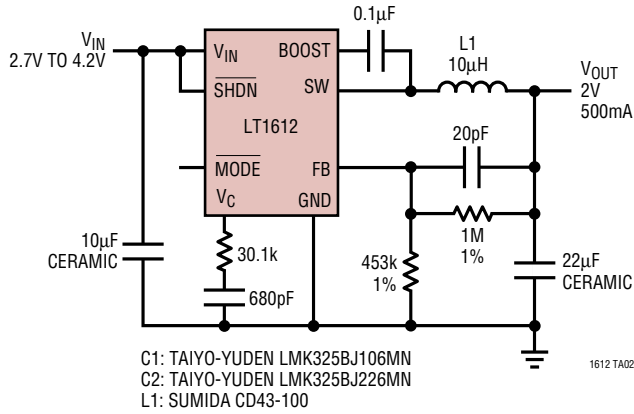

Figure 5. With the $\overline{\text{MODE}}$ Pin Tied High, Low Frequency Output Voltage Ripple Is No Longer Present

TYPICAL APPLICATIONS

Single Li-Ion to 2V Converter



Li-Ion to 2V Converter Efficiency

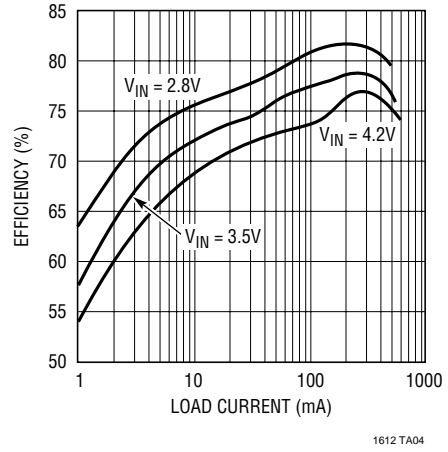

Transient Response

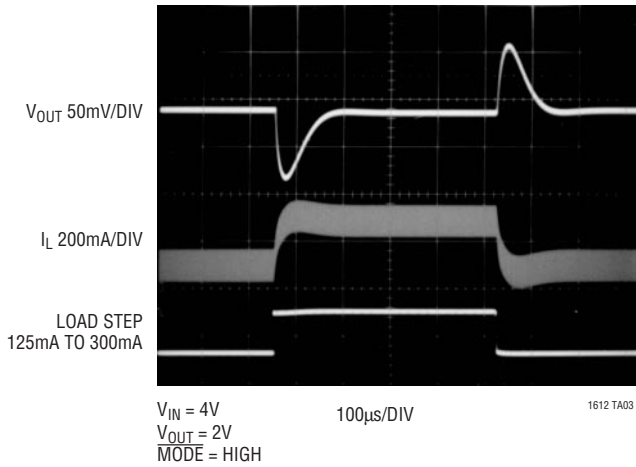

Burst Mode Operation

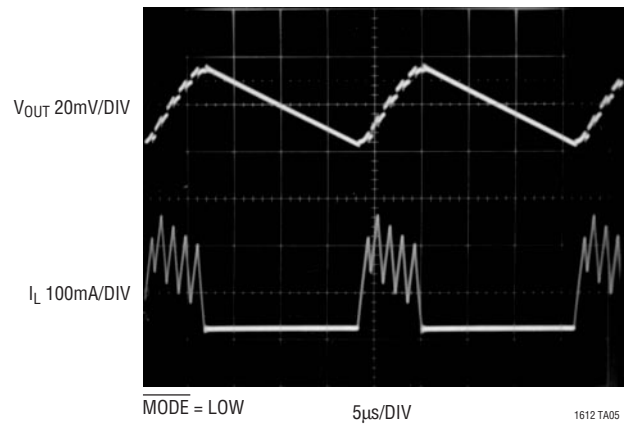

Inrush Current at Start-Up

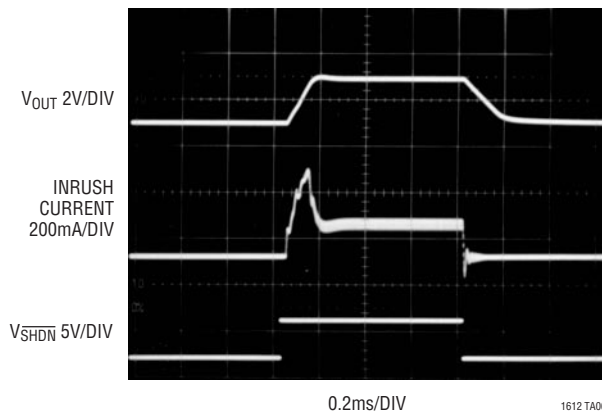

TYPICAL APPLICATIONS

5V to 2.5V Converter

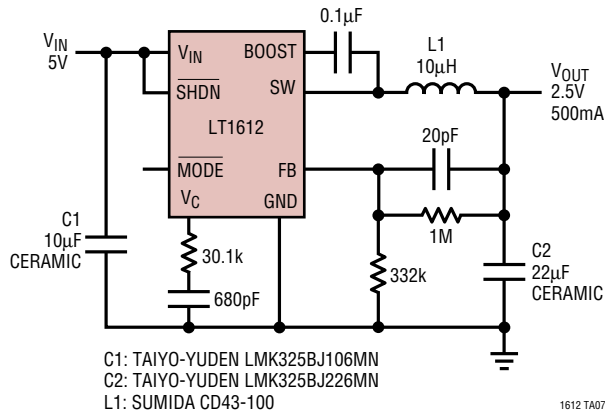

1612 TA07

5V to 2.5V Converter Efficiency

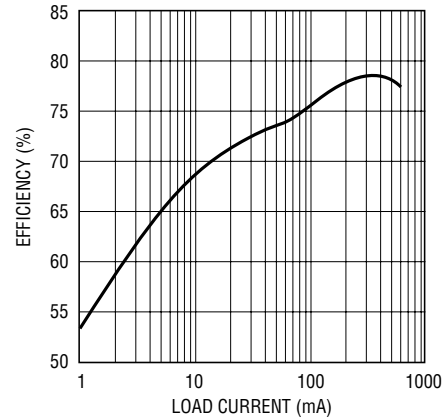

1612 TA08

2V to 0.9V Converter

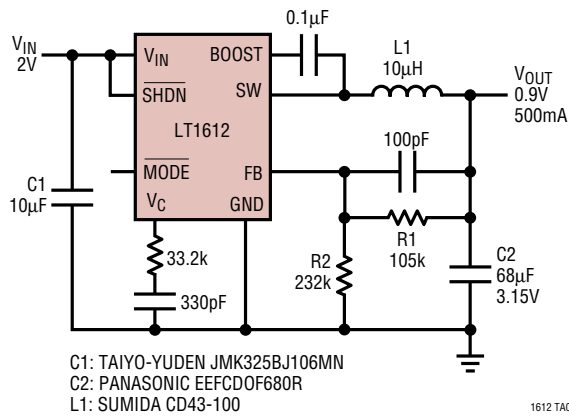

1612 TA09

Efficiency for LT1612 vs Linear Regulator.
 $V_{OUT} = 0.9V.$

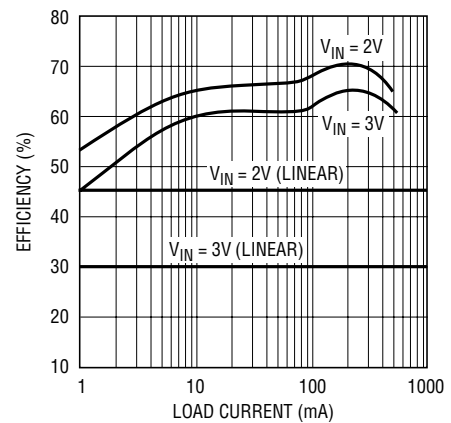

1612 TA10

PACKAGE DESCRIPTION

Dimension in inches (millimeters) unless otherwise noted.

**MS8 Package
8-Lead Plastic MSOP**
(LTC DWG # 05-08-1660)

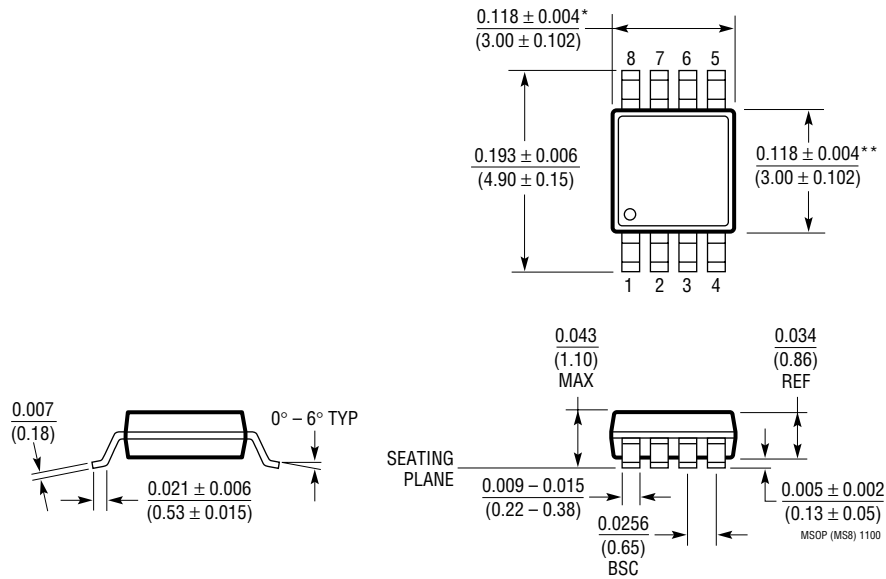

* DIMENSION DOES NOT INCLUDE MOLD FLASH, PROTRUSIONS OR GATE BURRS. MOLD FLASH, PROTRUSIONS OR GATE BURRS SHALL NOT EXCEED 0.006" (0.152mm) PER SIDE

** DIMENSION DOES NOT INCLUDE INTERLEAD FLASH OR PROTRUSIONS. INTERLEAD FLASH OR PROTRUSIONS SHALL NOT EXCEED 0.006" (0.152mm) PER SIDE

PACKAGE DESCRIPTION Dimension in inches (millimeters) unless otherwise noted.

S8 Package
8-Lead Plastic Small Outline (Narrow 0.150)
 (LTC DWG # 05-08-1610)

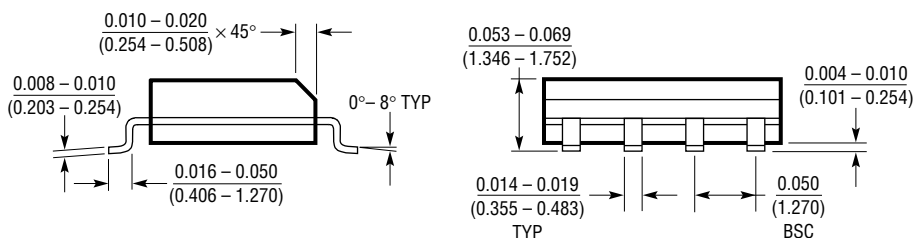
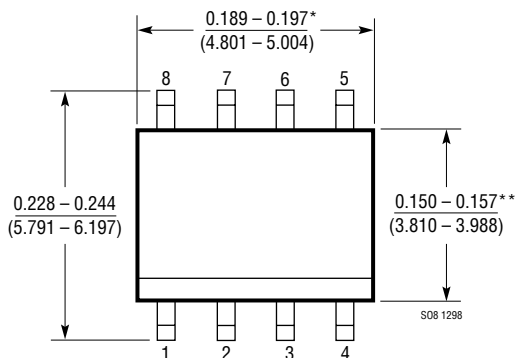

*DIMENSION DOES NOT INCLUDE MOLD FLASH. MOLD FLASH SHALL NOT EXCEED 0.006" (0.152mm) PER SIDE

**DIMENSION DOES NOT INCLUDE INTERLEAD FLASH. INTERLEAD FLASH SHALL NOT EXCEED 0.010" (0.254mm) PER SIDE

TYPICAL APPLICATION

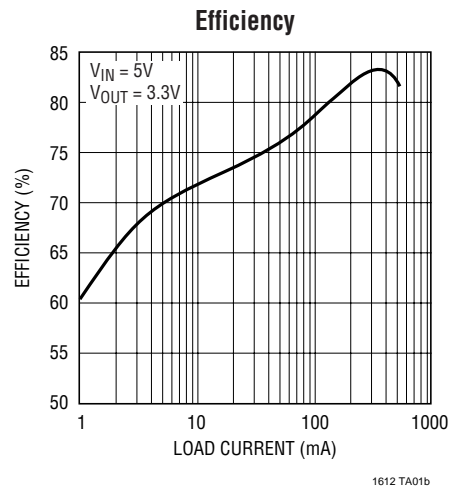
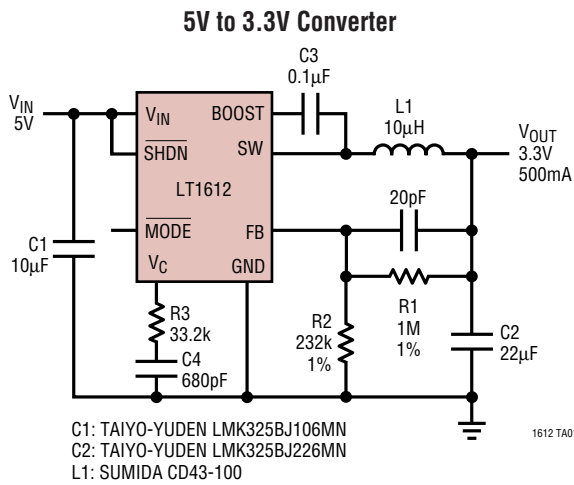

RELATED PARTS

PART NUMBER	DESCRIPTION	COMMENTS
LTC [®] 1474	Low I_Q Step-Down Switching Regulator	10µA I_Q , V_{IN} from 3V to 18V, MSOP Package up to 300mA
LT1616	600mA, 1.4MHz Step-Down Regulator in SOT-23	V_{IN} from 3.6V to 25V, SOT-23 Package
LTC1701	SOT-23 Step-Down Switching Regulator	500mA in SOT-23 Package, 1MHz Switching Frequency
LTC1707	Monolithic Synchronous Step-Down Switching Regulator	500mA, V_{IN} from 2.65V to 8.5V
LTC1772	Constant Frequency Step-Down Controller in SOT-23	High Current, High Efficiency: Up to 94%
LTC1877/LTC1878	High Efficiency, Monolithic Synchronous Step-Down Regulator	10µA I_Q , $2.65 \leq V_{IN} \leq 10V$, MSOP Package up to 600mA
LTC3404	1.4MHz High Efficiency Monolithic Synchronous Step-Down Reg	10µA I_Q , High Efficiency: up to 95%, MSOP Package

Looking for pricing, stock, or lifecycle information?

Click below to explore more details on WIN SOURCE:

 [View LT1612ES8#PBF on WIN SOURCE](#)

 [Linear Technology](#) Information

Optimize Your Supply Chain with WIN SOURCE Solutions

-  Global Sourcing Solution
-  Obsolete Management
-  Cost Control Management
-  Shortage Management
-  Alternative Solution
-  Excess Inventory Management