



**THE DATASHEET OF
LT1640AHCS8#PBF**



FEATURES

- Allows Safe Board Insertion and Removal from a Live -48V Backplane
- Operates from -10V to -80V
- Programmable Inrush Current
- Allows 50mA of Reverse Drain Pin Current
- Programmable Electronic Circuit Breaker
- Programmable Overvoltage Protection
- Programmable Undervoltage Lockout
- Power Good Control Output

APPLICATIONS

- Central Office Switching
- -48V Distributed Power Systems
- Negative Power Supply Control

DESCRIPTION

The LT[®]1640AL/LT1640AH are 8-pin, negative voltage Hot Swap[™] controllers that allow a board to be safely inserted and removed from a live backplane. Inrush current is limited to a programmable value by controlling the gate voltage of an external N-channel pass transistor. The pass transistor is turned off if the input voltage is less than the programmable undervoltage threshold or greater than the overvoltage threshold. A programmable electronic circuit breaker protects the system against shorts. The PWRGD (LT1640AL) or PWRGD (LT1640AH) signal can be used to directly enable a power module. The LT1640AL is designed for modules with a low enable input and the LT1640AH for modules with a high enable input.

The LT1640AL/LT1640AH are available in 8-pin PDIP and SO packages.

LT, LTC and LT are registered trademarks of Linear Technology Corporation. Hot Swap is a trademark of Linear Technology Corporation.

TYPICAL APPLICATION

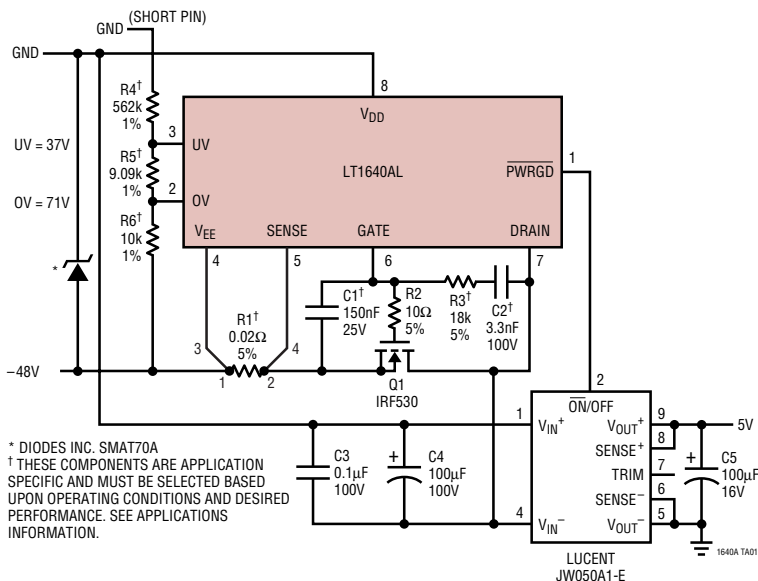

Input Inrush Current

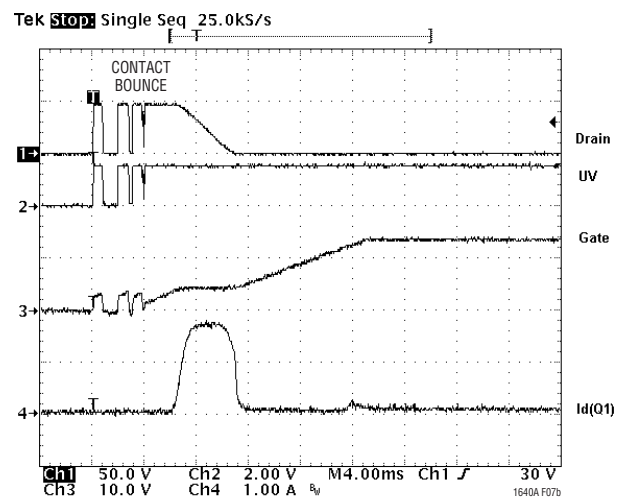

LT1640AL/LT1640AH

ABSOLUTE MAXIMUM RATINGS (Note 1), All Voltages Referred to V_{EE}

Supply Voltage (V _{DD} – V _{EE})	–0.3V to 100V	Operating Temperature Range	
PWRGD, PWRGD Pins	–0.3V to 100V	LT1640ALC/LT1640AHC	0°C to 70°C
DRAIN Pin	–2V to 100V	LT1640ALI/LT1640AHI	–40°C to 85°C
SENSE, GATE Pins	–0.3V to 20V	Storage Temperature Range	–65°C to 150°C
UV, OV Pins	–0.3V to 60V	Lead Temperature (Soldering, 10 sec)	300°C
Maximum Junction Temperature	125°C		

PACKAGE/ORDER INFORMATION

<p>N8 PACKAGE 8-LEAD PDIP</p> <p>S8 PACKAGE 8-LEAD PLASTIC SO</p> <p>T_{JMAX} = 125°C, θ_{JA} = 120°C/W (N8) T_{JMAX} = 125°C, θ_{JA} = 150°C/W (S8)</p>	ORDER PART NUMBER	<p>N8 PACKAGE 8-LEAD PDIP</p> <p>S8 PACKAGE 8-LEAD PLASTIC SO</p> <p>T_{JMAX} = 125°C, θ_{JA} = 120°C/W (N8) T_{JMAX} = 125°C, θ_{JA} = 150°C/W (S8)</p>	ORDER PART NUMBER
	LT1640ALCN8 LT1640ALCS8 LT1640ALIN8 LT1640ALIS8		LT1640AHCN8 LT1640AHCS8 LT1640AHIN8 LT1640AHIS8
	S8 PART MARKING		S8 PART MARKING
	1640AL 640ALI		1640AH 640AHI

Consult factory for parts specified with wider operating temperature ranges.

ELECTRICAL CHARACTERISTICS The ● denotes the specifications which apply over the full operating temperature range, otherwise specifications are at T_A = 25°C. (Note 2), V_{DD} = 48V, V_{EE} = 0V unless otherwise noted.

SYMBOL	PARAMETER	CONDITIONS	MIN	TYP	MAX	UNITS	
DC							
V _{DD}	Supply Operating Range		●	10	80	V	
I _{DD}	Supply Current	UV = 3V, OV = V _{EE} , SENSE = V _{EE}	●	1.3	5	mA	
V _{CB}	Circuit Breaker Trip Voltage	V _{CB} = (V _{SENSE} – V _{EE})	●	40	50	60	mV
I _{PU}	GATE Pin Pull-Up Current	Gate Drive On, V _{GATE} = V _{EE}	●	–30	–45	–60	μA
I _{PD}	GATE Pin Pull-Down Current	Any Fault Condition		24	50	70	mA
I _{SENSE}	SENSE Pin Current	V _{SENSE} = 50mV		–20		μA	
ΔV _{GATE}	External Gate Drive	(V _{GATE} – V _{EE}), 15V ≤ V _{DD} ≤ 80V	●	10	13.5	18	V
		(V _{GATE} – V _{EE}), 10V ≤ V _{DD} < 15V	●	6	8	15	V
V _{UVH}	UV Pin High Threshold Voltage	UV Low to High Transition	●	1.213	1.243	1.272	V
V _{UVL}	UV Pin Low Threshold Voltage	UV High to Low Transition	●	1.198	1.223	1.247	V
V _{UVHY}	UV Pin Hysteresis			20		mV	
I _{INUV}	UV Pin Input Current	V _{UV} = V _{EE}	●	–0.02	–0.5	μA	
V _{OVH}	OV Pin High Threshold Voltage	OV Low to High Transition	●	1.198	1.223	1.247	V
V _{OVL}	OV Pin Low Threshold Voltage	OV High to Low Transition	●	1.165	1.203	1.232	V
V _{OVHY}	OV Pin Hysteresis			20		mV	
I _{INOV}	OV Pin Input Current	V _{OV} = V _{EE}	●	–0.03	–0.5	μA	

ELECTRICAL CHARACTERISTICS The ● denotes the specifications which apply over the full operating temperature range, otherwise specifications are at $T_A = 25^\circ\text{C}$. (Note 2), $V_{DD} = 48\text{V}$, $V_{EE} = 0\text{V}$ unless otherwise noted.

SYMBOL	PARAMETER	CONDITIONS	MIN	TYP	MAX	UNITS
V_{PG}	Power Good Threshold	$V_{DRAIN} - V_{EE}$, High to Low Transition	1.1	1.4	2.0	V
V_{PGHY}	Power Good Threshold Hysteresis			0.4		V
I_{DRAIN}	Drain Input Bias Current	$V_{DRAIN} = 48\text{V}$	● 10	50	500	μA
V_{OL}	PWRGD Output Low Voltage	PWRGD (LT1640AL), ($V_{DRAIN} - V_{EE}$) < V_{PG} $I_{OUT} = 1\text{mA}$ $I_{OUT} = 5\text{mA}$	●	0.48 1.50	0.8 3.0	V V
	PWRGD Output Low Voltage (PWRGD – DRAIN)	PWRGD (LT1640AH), $V_{DRAIN} = 5\text{V}$ $I_{OUT} = 1\text{mA}$	●	0.75	1.0	V
I_{OH}	Output Leakage	PWRGD (LT1640AL), $V_{DRAIN} = 48\text{V}$, $V_{PWRGD} = 80\text{V}$	●	0.05	10	μA
R_{OUT}	Power Good Output Impedance (PWRGD to DRAIN)	PWRGD (LT1640AH), ($V_{DRAIN} - V_{EE}$) < V_{PG}	● 2	6.5		$\text{k}\Omega$

AC

t_{PHLOV}	OV High to GATE Low	Figures 1, 2		1.7		μs
t_{PHLUV}	UV Low to GATE Low	Figures 1, 3		1.5		μs
t_{PLHOV}	OV Low to GATE High	Figures 1, 2		5.5		μs
t_{PLHUV}	UV High to GATE High	Figures 1, 3		6.5		μs
$t_{PHLSENSE}$	SENSE High to Gate Low	Figures 1, 4	2	3	4	μs
t_{PHLPG}	DRAIN Low to PWRGD Low	(LT1640AL) Figures 1, 5		0.5		μs
	DRAIN Low to (PWRGD – DRAIN) High	(LT1640AH) Figures 1, 5		0.5		μs
t_{PLHPG}	DRAIN High to PWRGD High	(LT1640AL) Figures 1, 5		0.5		μs
	DRAIN High to (PWRGD – DRAIN) Low	(LT1640AH) Figures 1, 5		0.5		μs

Note 1: Absolute Maximum Ratings are those values beyond which the life of a device may be impaired.

Note 2: All currents into device pins are positive; all currents out of device pins are negative. All voltages are referenced to V_{EE} unless otherwise specified.

TYPICAL PERFORMANCE CHARACTERISTICS

Supply Current vs Supply Voltage

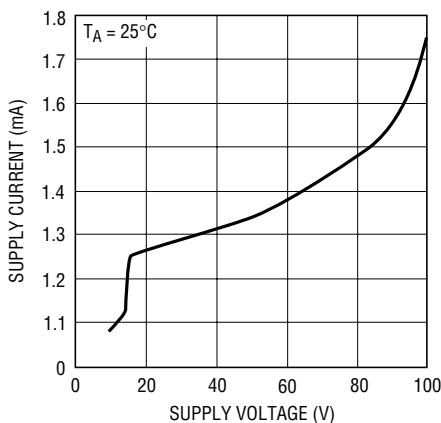

1640A G01

Supply Current vs Temperature

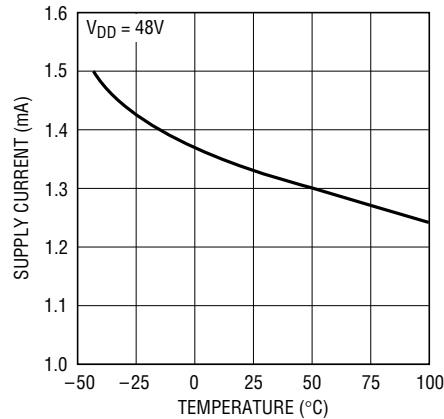

1640A G02

Gate Voltage vs Supply Voltage

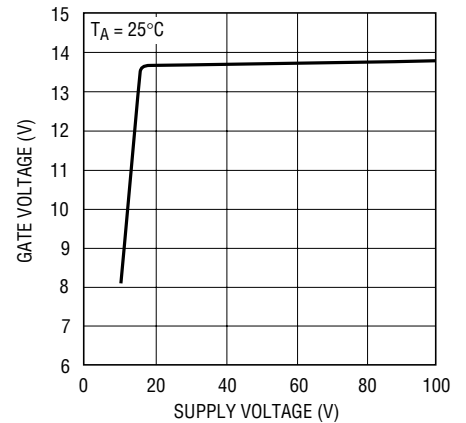

1640A G03

TYPICAL PERFORMANCE CHARACTERISTICS

Gate Voltage vs Temperature

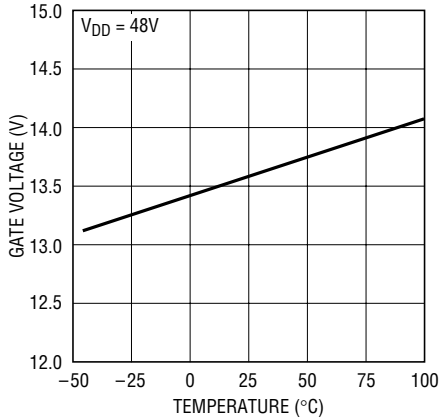

1640A G04

Circuit Breaker Trip Voltage vs Temperature

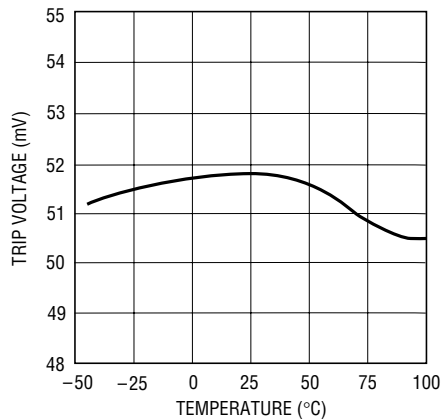

1640A G05

Gate Pull-Up Current vs Temperature

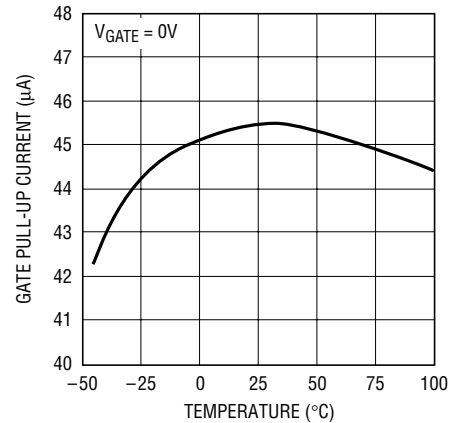

1640A G06

Gate Pull-Down Current vs Temperature

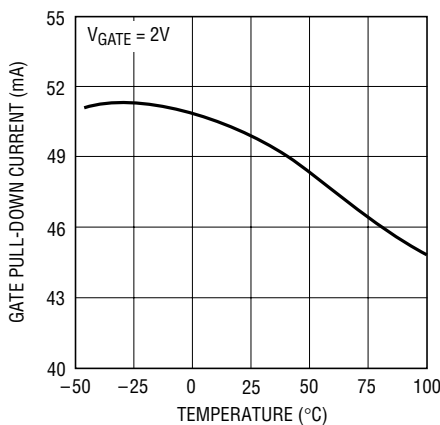

1640A G07

PWRGD Output Low Voltage vs Temperature (LT1640AL)

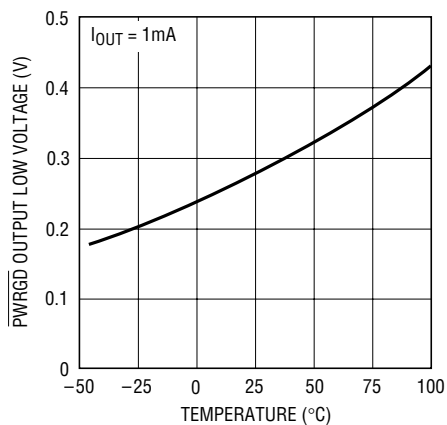

1640A G08

PWRGD Output Impedance vs Temperature (LT1640AH)

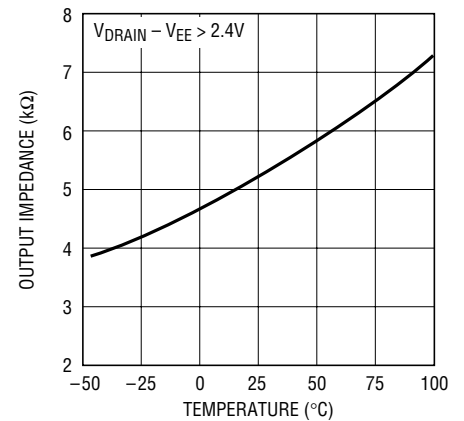

1640A G09

PIN FUNCTIONS

PWRGD/PWRGD (Pin 1): Power Good Output Pin. This pin will toggle when V_{DRAIN} is within V_{PG} of V_{EE} . This pin can be connected directly to the enable pin of a power module.

When the DRAIN pin of the LT1640AL is above V_{EE} by more than V_{PG} , the PWRGD pin will be high impedance, allowing the pull-up current of the module's enable pin to pull the pin high and turn the module off. When V_{DRAIN} drops below V_{PG} , the PWRGD pin sinks current to V_{EE} , pulling the enable pin low and turning on the module.

When the DRAIN pin of the LT1640AH is above V_{EE} by more than V_{PG} , the PWRGD pin will sink current to the DRAIN pin which pulls the module's enable pin low, forcing it off. When V_{DRAIN} drops below V_{PG} , the PWRGD sink current is turned off and a 6.5k resistor is connected between PWRGD and DRAIN, allowing the module's pull-up current to pull the enable pin high and turn on the module.

PIN FUNCTIONS

OV (Pin 2): Analog Overvoltage Input. When OV is pulled above the 1.223V low-to-high threshold, an overvoltage condition is detected and the GATE pin will be immediately pulled low. The GATE pin will remain low until OV drops below the 1.203V high-to-low threshold.

UV (Pin 3): Analog Undervoltage Input. When UV is pulled below the 1.223V high to low threshold, an undervoltage condition is detected and the GATE pin will be immediately pulled low. The GATE pin will remain low until UV rises above the 1.243 low-to-high threshold.

The UV pin is also used to reset the electronic circuit breaker. If the UV pin is cycled low and high following the trip of the circuit breaker, the circuit breaker is reset and a normal power-up sequence will occur.

V_{EE} (Pin 4): Negative Supply Voltage Input. Connect to the lower potential of the power supply.

SENSE (Pin 5): Circuit Breaker Sense Pin. With a sense resistor placed in the supply path between V_{EE} and SENSE, the circuit breaker will trip when the voltage across the resistor exceeds 50mV. Noise spikes of less than 2μs are filtered out and will not trip the circuit breaker.

If the circuit breaker trip current is set to twice the normal operating current, only 25mV is dropped across the sense resistor during normal operation. To disable the circuit breaker, V_{EE} and SENSE can be shorted together.

GATE (Pin 6): Gate Drive Output for the External N-Channel. The GATE pin will go high when the following start-up conditions are met: the UV pin is high, the OV pin is low and $(V_{SENSE} - V_{EE}) < 50mV$. The GATE pin is pulled high by a 45μA current source and pulled low with a 50mA current source.

DRAIN (Pin 7): Analog Drain Sense Input. Connect this pin to the drain of the external N-channel and the V⁻ pin of the power module. When the DRAIN pin is below V_{PG}, the PWRGD or PWRGD pin will toggle. In some conditions, the DRAIN pin is pulled below V_{EE}. The part is not damaged if the reverse DRAIN pin current is limited to 50mA.

V_{DD} (Pin 8): Positive Supply Voltage Input. Connect this pin to the higher potential of the power supply inputs and the V⁺ pin of the power module. The input supply voltage ranges from 10V to 80V.

BLOCK DIAGRAM

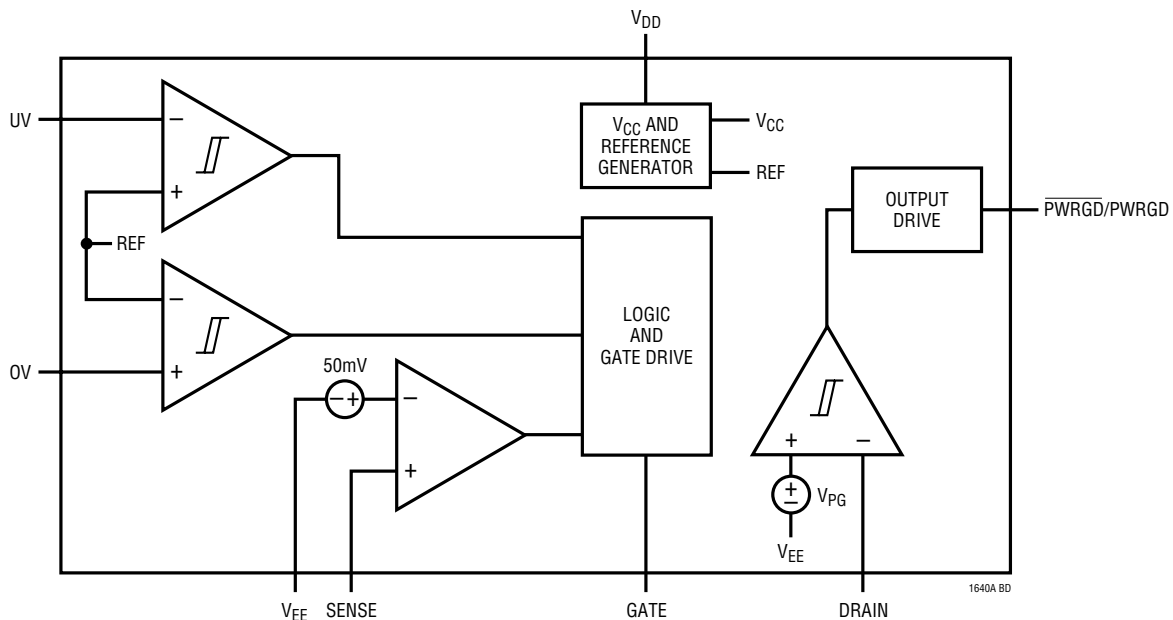

TEST CIRCUIT

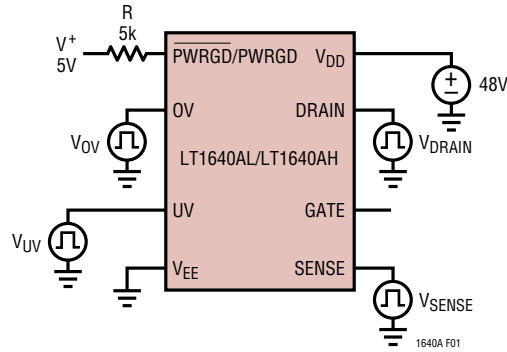

Figure 1. Test Circuit

TIMING DIAGRAMS

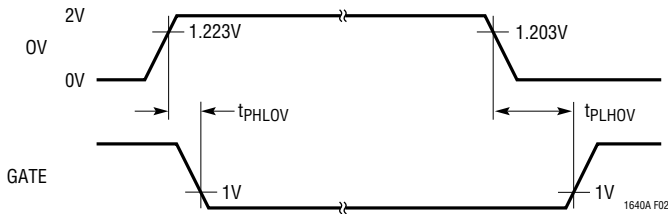

Figure 2. OV to GATE Timing

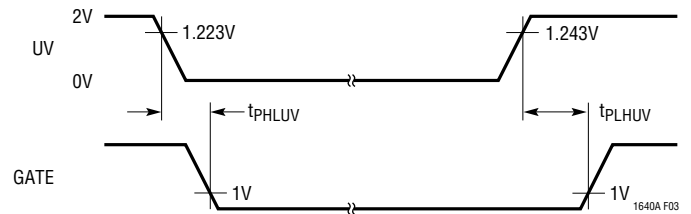

Figure 3. UV to GATE Timing

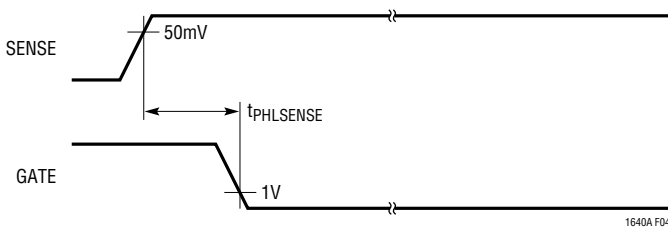

Figure 4. SENSE to GATE Timing

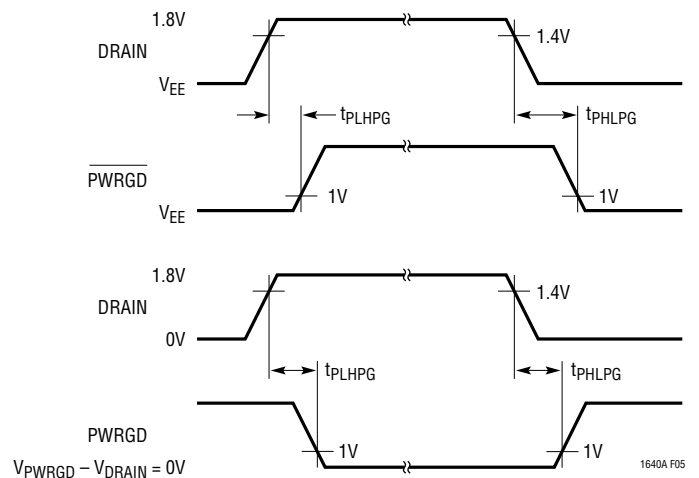

Figure 5. DRAIN to $\overline{PWRGD}/PWRGD$ Timing

APPLICATIONS INFORMATION

Hot Circuit Insertion

When circuit boards are inserted into a live –48V backplane, the bypass capacitors at the input of the board’s power module or switching power supply can draw huge transient currents as they charge up. The transient currents can cause permanent damage to the board’s components and cause glitches on the system power supply.

The LT1640A is designed to turn on a board’s supply voltage in a controlled manner, allowing the board to be safely inserted or removed from a live backplane. The chip also provides undervoltage, overvoltage and overcurrent protection while keeping the power module off until its input voltage is stable and within tolerance.

Power Supply Ramping

The input to the power module on a board is controlled by placing an external N-channel pass transistor (Q1) in the power path (Figure 6a, all waveforms are with respect to the V_{EE} pin of the LT1640A). R1 provides current fault detection and R2 prevents high frequency oscillations. Resistors R4, R5 and R6 provide undervoltage and overvoltage sensing. By ramping the gate of Q1 up at a slow rate, the surge current charging load capacitors C3 and C4 can be limited to a safe value when the board makes connection.

Resistor R3 and capacitor C2 act as a feedback network to accurately control the inrush current. The inrush current can be calculated with the following equation:

$$I_{INRUSH} = (45\mu A \cdot C_L) / C2$$

where C_L is the total load capacitance equal to C3 + C4 + module input capacitance.

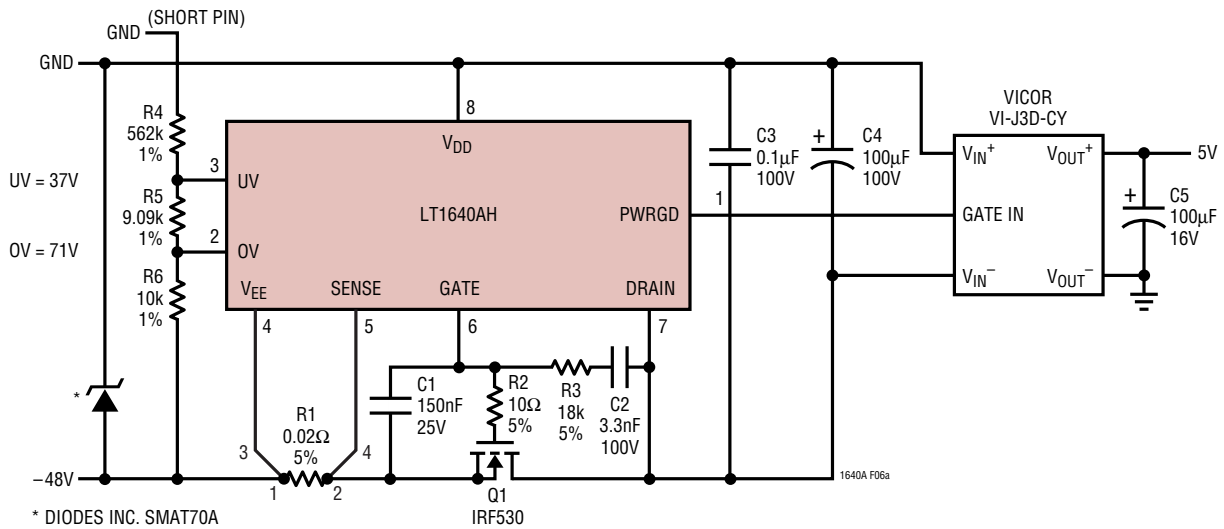

Figure 6a. Inrush Control Circuitry

APPLICATIONS INFORMATION

Capacitor C1 and resistor R3 prevent Q1 from momentarily turning on when the power pins first make contact. Without C1 and R3, capacitor C2 would pull the gate of Q1 up to a voltage roughly equal to $V_{EE} \cdot C2/C_{GS}(Q1)$ before the LT1640A could power up and actively pull the gate low. By placing capacitor C1 in parallel with the gate capacitance of Q1 and isolating them from C2 using resistor R3, the problem is solved. The value of C1 should be:

$$\left(\frac{V_{INMAX} - V_{TH}}{V_{TH}} \right) \cdot (C2 + C_{GD})$$

where V_{TH} is the MOSFET's minimum gate threshold and V_{INMAX} is the maximum operating input voltage.

R3's value is not critical and is given by $(V_{INMAX} + \Delta V_{GATE})/5mA$.

The waveforms are shown in Figure 6b. When the power pins make contact, they bounce several times. While the contacts are bouncing, the LT1640A senses an undervoltage condition and the GATE is immediately pulled low when the power pins are disconnected.

Once the power pins stop bouncing, the GATE pin starts to ramp up. When Q1 turns on, the GATE voltage is held constant by the feedback network of R3 and C2. When the DRAIN voltage has finished ramping, the GATE pin then ramps to its final value.

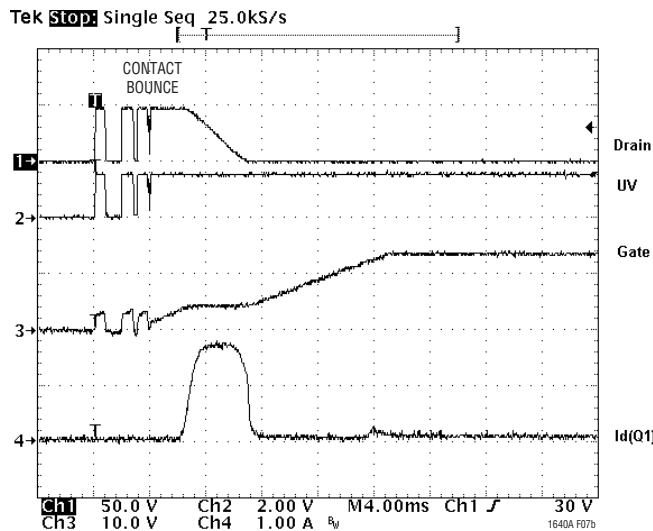

Figure 6b. Inrush Control Waveforms

APPLICATIONS INFORMATION

Electronic Circuit Breaker

The LT1640A features an electronic circuit breaker function that protects against short circuits or excessive supply currents. By placing a sense resistor between the V_{EE} and SENSE pin, the circuit breaker will be tripped whenever the voltage across the sense resistor is greater than 50mV for more than $3\mu\text{s}$ as shown in Figure 7.

Note that the circuit breaker threshold should be set sufficiently high to account for the sum of the load current and the inrush current. If the load current can be controlled by the $\overline{\text{PWRGD}}$ /PWRGD pin (as in Figure 6a), the threshold can be set lower, since it will never need to accommodate inrush current and load current simultaneously.

When the circuit breaker trips, the GATE pin is immediately pulled to V_{EE} and the external N-channel turns off. The GATE pin will remain low until the circuit breaker is reset by pulling UV low, then high or cycling power to the part.

If more than $3\mu\text{s}$ deglitching time is needed to reject current noise, an external resistor and capacitor can be added to the sense circuit as shown in Figure 8. R7 and C3 act as a lowpass filter that will slow down the SENSE pin voltage from rising too fast. Since the SENSE pin will source current, typically $20\mu\text{A}$, there will be a voltage drop

on R7. This voltage will be counted into the circuit breaker trip voltage just as the voltage across the sense resistor. A small resistor is recommended for R7. A 100Ω for R7 will cause a 2mV error. The following equation can be used to estimate the delay time at the SENSE pin:

$$t = -R \cdot C \cdot \ln \left(1 - \frac{V(t) - V(t_0)}{V_i - V(t_0)} \right)$$

Where $V(t)$ is the circuit breaker trip voltage, typically 50mV. $V(t_0)$ is the voltage drop across the sense resistor before the short or overcurrent condition occurs. V_i is the voltage across the sense resistor when the short current or overcurrent is applied on it.

Example: A system has a 1A current load and a 0.02Ω sense resistor is used. An extended delay circuit needs to be designed for a $50\mu\text{s}$ delay time after the load jumps to 5A. In this case:

$$V(t) = 50\text{mV}$$

$$V(t_0) = 20\text{mV}$$

$$V_i = 5\text{A} \cdot 0.02\Omega = 100\text{mV}$$

If we choose $R = 100\Omega$, we will get $C = 1\mu\text{F}$.

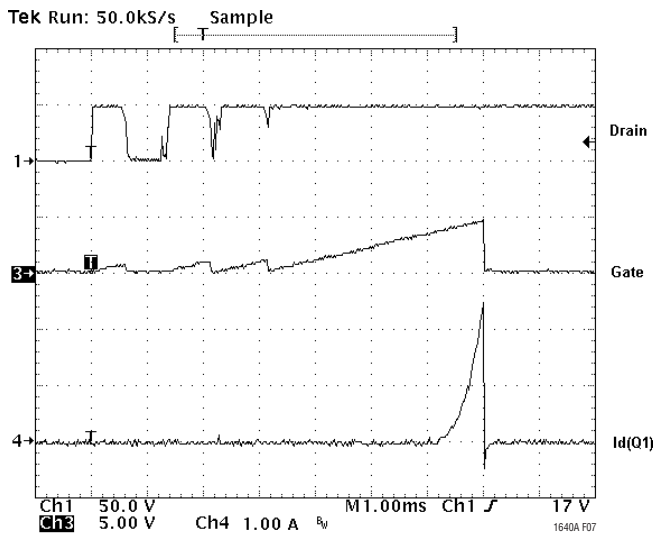

Figure 7. Short-Circuit Protection Waveforms

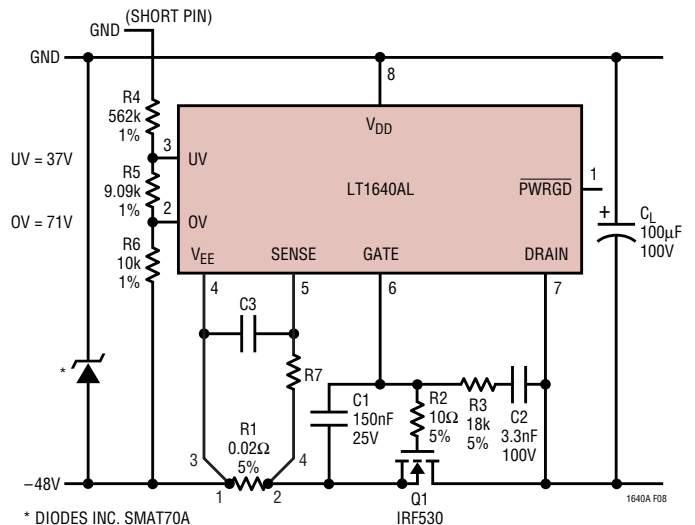

Figure 8. Extending the Short-Circuit Protection Delay

APPLICATIONS INFORMATION

Under some conditions, a short circuit at the output can cause the input supply to dip below the UV threshold, resetting the circuit breaker immediately.

The LT1640A then cycles on and off repeatedly until the short is removed. This can be minimized by adding a deglitching delay to the UV pin with a capacitor from UV to V_{EE} . This capacitor forms an RC time constant with the resistors at UV, allowing the input supply to recover before the UV pin resets the circuit breaker.

A circuit that automatically resets the circuit breaker after a current fault is shown in Figure 9.

Transistors Q2 and Q3 along with R7, R8, C4 and D1 form a programmable one-shot circuit. Before a short occurs, the GATE pin is pulled high and Q3 is turned on, pulling node 2 to V_{EE} . Resistor R8 turns off Q2. When a short occurs, the GATE pin is pulled low and Q3 turns off. Node 2 starts to charge C4 and Q2 turns on, pulling the UV pin low and resetting the circuit breaker. As soon as C4 is fully charged, R8 turns off Q2, UV goes high and the GATE starts to ramp up. Q3 turns back on and quickly pulls node 2 back to V_{EE} . Diode D1 clamps node 3 one diode drop below V_{EE} . The duty cycle is set to 10% to prevent Q1 from overheating.

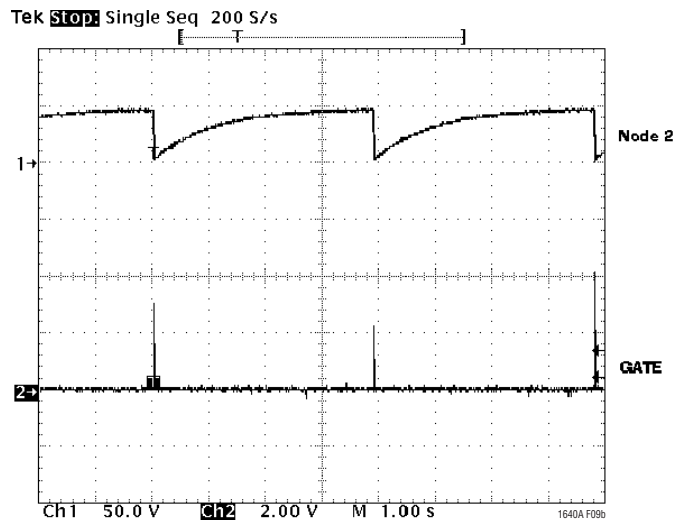
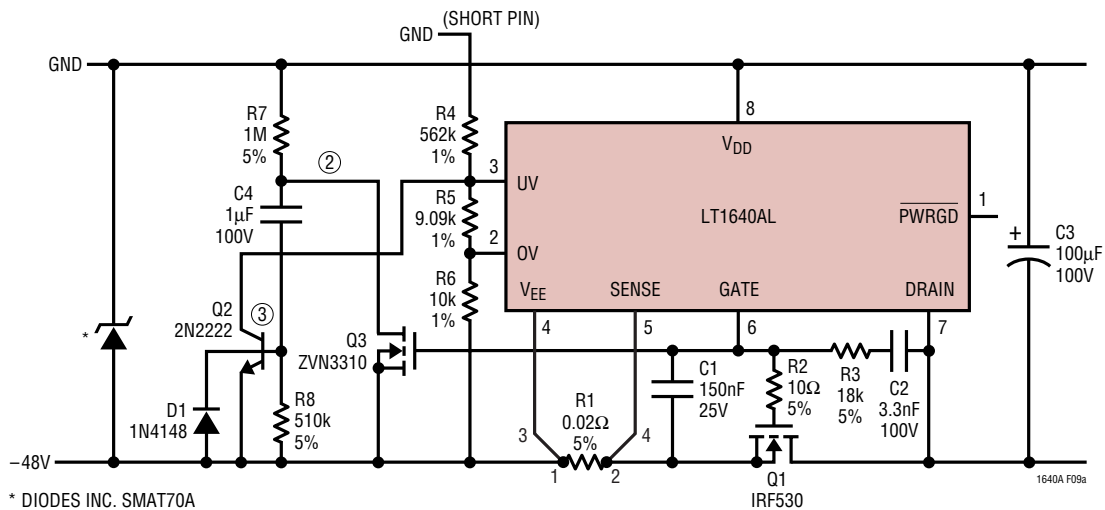

Figure 9. Automatic Restart After Current Fault

APPLICATIONS INFORMATION

Undervoltage and Overvoltage Detection

The UV (Pin 3) and OV (Pin 2) pins can be used to detect undervoltage and overvoltage conditions at the power supply input. The UV and OV pins are internally connected to analog comparators with 20mV of hysteresis. When the UV pin falls below its threshold or the OV pin rises above its threshold, the GATE pin is immediately pulled low. The GATE pin will be held low until UV is high and OV is low.

The undervoltage and overvoltage trip voltages can be programmed using a three resistor divider as shown in

Figure 10a. With R4 = 562k, R5 = 9.09k and R6 = 10k, the undervoltage threshold is set to 37V and the overvoltage threshold is set to 71V. The resistor divider will also amplify the 20mV hysteresis at the UV pin and OV pin to 0.6V and 1.2V at the input, respectively.

More hysteresis can be added to the UV threshold by connecting resistor R3 between the UV pin and the GATE pin as shown in Figure 10b.

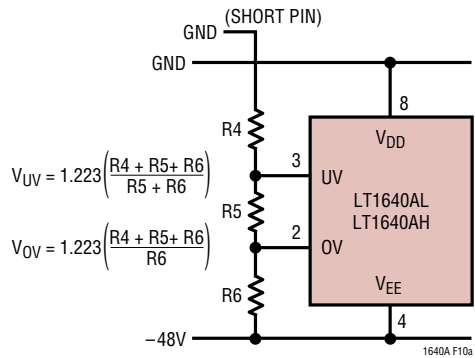

Figure 10a. Undervoltage and Overvoltage Sensing

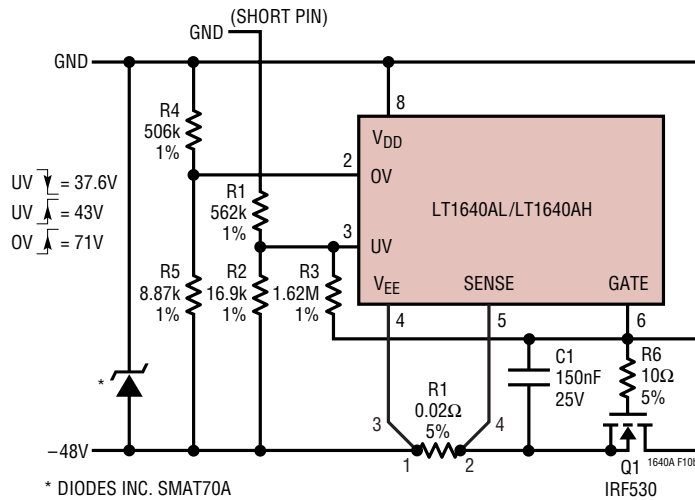

Figure 10b. Programmable Hysteresis for Undervoltage Detection

APPLICATIONS INFORMATION

The new threshold voltage when the input moves from low to high is:

$$V_{UV,LH} = V_{UVH} \left(\frac{R2 \cdot R3 + R1 \cdot R3 + R1 \cdot R2}{R2 \cdot R3} \right)$$

where V_{UVH} is typically 1.243V.

The new threshold voltage when the input moves from high to low is:

$$V_{UV,HL} = V_{UVL} \left(\frac{R2 \cdot R3 + R1 \cdot R3 + R1 \cdot R2}{R2 \cdot R3} \right) - \left(V_{GATE} \cdot \frac{R1}{R3} \right)$$

where V_{UVL} is typically 1.223V.

The new hysteresis value will be:

$$V_{HYS} = V_{UVHY} \left(\frac{R2 \cdot R3 + R1 \cdot R3 + R1 \cdot R2}{R2 \cdot R3} \right) + \left(V_{GATE} \cdot \frac{R1}{R3} \right)$$

With $R1 = 562k$, $R2 = 16.9k$ and $R3 = 1.62M$, $V_{GATE} = 13.5V$ and $V_{UVHY} = 20mV$, the undervoltage threshold will be 43V (from low to high) and 37.6V (from high to low). The hysteresis is 5.4V. A separate resistor divider should be used to set the overvoltage threshold given by:

$$V_{OV} = V_{OVH} \left(\frac{R4 + R5}{R5} \right)$$

With $R4 = 506k$, $R5 = 8.87k$ and $V_{OVH} = 1.223V$, the overvoltage threshold will be 71V.

\overline{PWRGD} /PWRGD Output

The \overline{PWRGD} /PWRGD output can be used to directly enable a power module when the input voltage to the module is within tolerance. The LT1640AL has a \overline{PWRGD} output for modules with an active low enable input, and the LT1640AH has a PWRGD output for modules with an active high enable input.

When the DRAIN voltage of the LT1640AH is high with respect to V_{EE} (Figure 11), the internal transistor Q3 is turned off and R7 and Q2 clamp the PWRGD pin one diode drop ($\approx 0.7V$) above the DRAIN pin. Transistor Q2 sinks the module's pull-up current and the module turns off.

When the DRAIN voltage drops below V_{PG} , Q3 will turn on, shorting the bottom of R7 to DRAIN and turning Q2 off. The pull-up current in the module then flows through R7, pulling the PWRGD pin high and enabling the module.

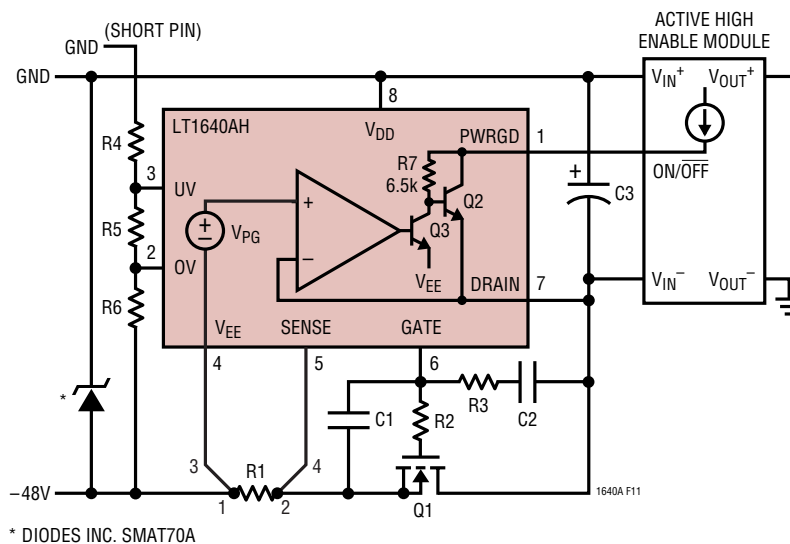

Figure 11. Active High Enable Module

APPLICATIONS INFORMATION

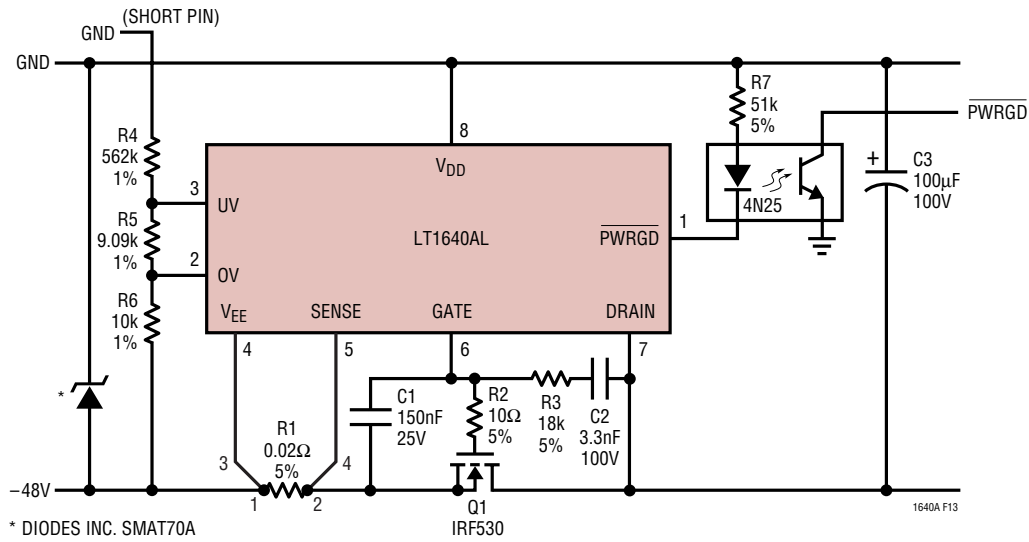
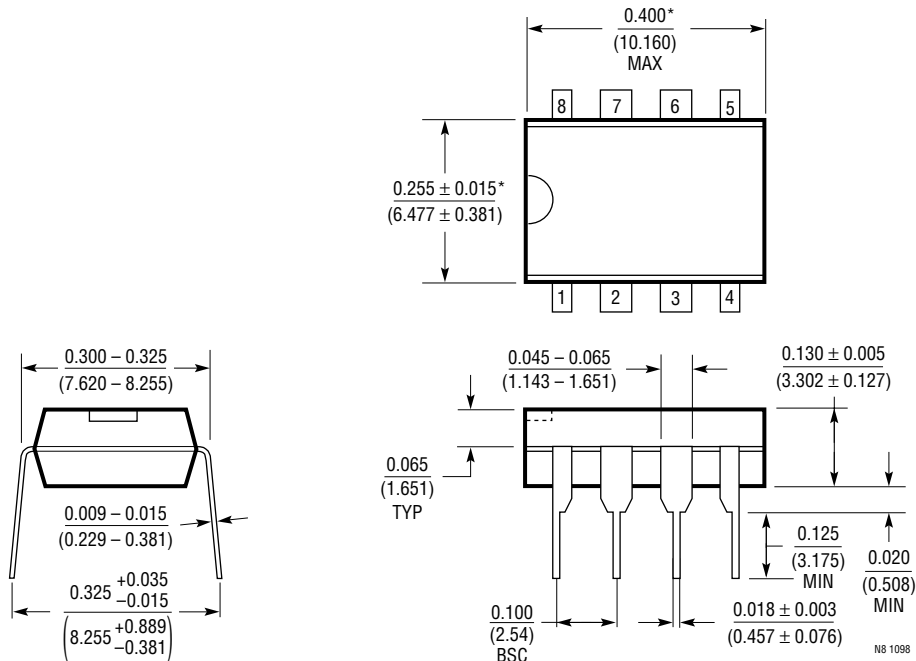

Figure 13. Using PWRGD to Drive an Optoisolator

PACKAGE DESCRIPTION

Dimensions in inches (millimeters) unless otherwise noted.

N8 Package
8-Lead PDIP (Narrow 0.300)
 (LTC DWG # 05-08-1510)



*THESE DIMENSIONS DO NOT INCLUDE MOLD FLASH OR PROTRUSIONS.
 MOLD FLASH OR PROTRUSIONS SHALL NOT EXCEED 0.010 INCH (0.254mm)

PACKAGE DESCRIPTION Dimensions in inches (millimeters) unless otherwise noted.

S8 Package
8-Lead Plastic Small Outline (Narrow 0.150)
 (LTC DWG # 05-08-1610)

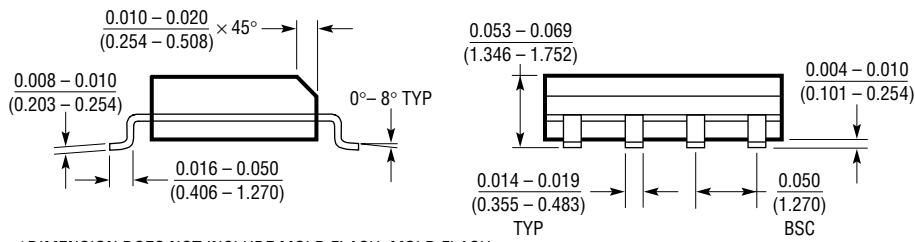
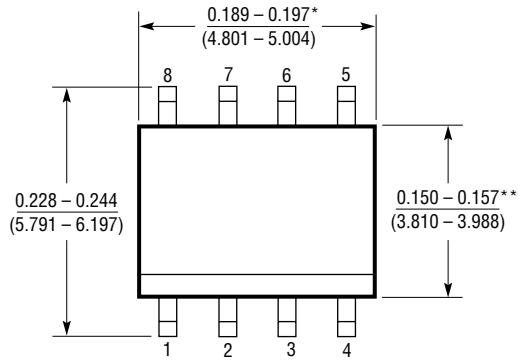

*DIMENSION DOES NOT INCLUDE MOLD FLASH. MOLD FLASH SHALL NOT EXCEED 0.006" (0.152mm) PER SIDE

**DIMENSION DOES NOT INCLUDE INTERLEAD FLASH. INTERLEAD FLASH SHALL NOT EXCEED 0.010" (0.254mm) PER SIDE

S08 1298

TYPICAL APPLICATION

Using an EMI Filter Module

Many applications place an EMI filter module in the power path to prevent switching noise of the module from being injected back onto the power supply. A typical application

using the Lucent FLTR100V10 filter module is shown in Figure 14. When using a filter, an optoisolator is required to prevent common mode transients from destroying the PWRGD and $\overline{\text{ON/OFF}}$ pins.

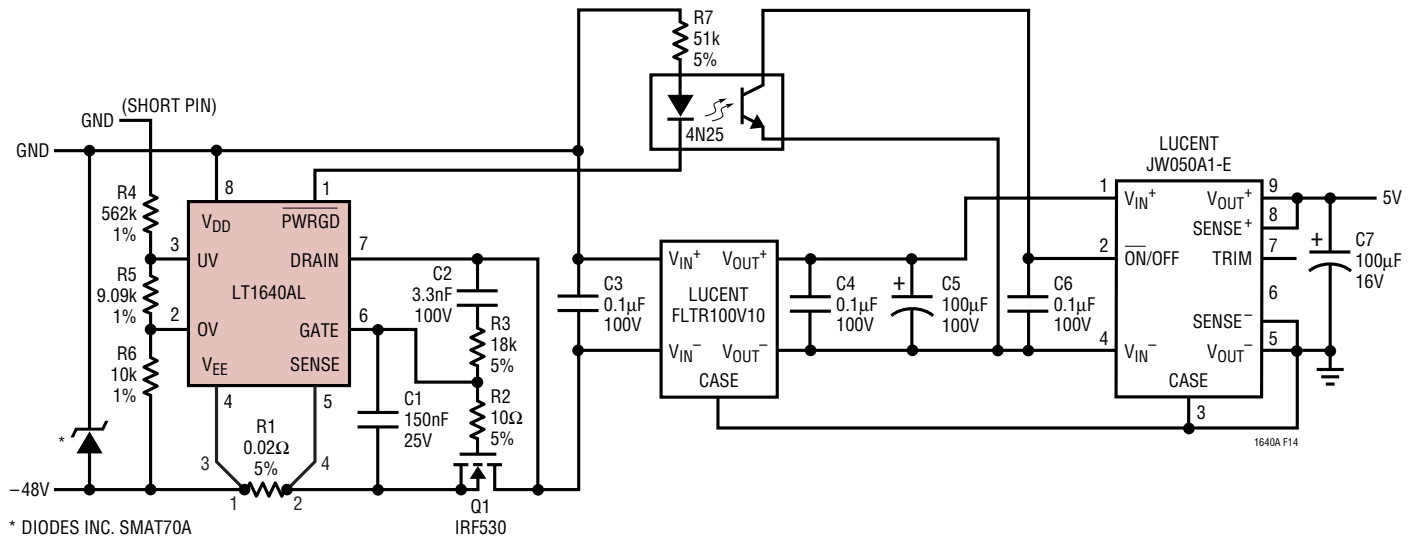

Figure 14. Typical Application Using a Filter Module

RELATED PARTS

PART NUMBER	DESCRIPTION	COMMENTS
LTC [®] 1421	Dual Channel, Hot Swap Controller	Operates from 3V to 12V
LTC1422	Hot Swap Controller in SO-8	System Reset Output with Programmable Delay, 3V to 12V
LT1641	Positive 48V Hot Swap Controller in SO-8	Foldback Analog Current Limit
LTC1642	Fault Protected Hot Swap Controller	Operates Up to 16.5V, Protected to 33V
LTC1643	PCI Hot Swap Controller	3.3V, 5V, 12V, -12V Supplies for PCI Bus
LTC1645	Dual Hot Swap Controller	Operates from 1.2V to 12V, Power Sequencing
LTC1646	CompactPCI [™] Hot Swap Controller	3.3V, 5V Supplies, 1V Precharge, Local PCI Reset Logic
LTC1647	Dual Hot Swap Controller	Dual ON Pins for Supplies from 3V to 15V

CompactPCI is a trademark of the PCI Industrial Computer Manufacturers Group

Looking for pricing, stock, or lifecycle information?

Click below to explore more details on WIN SOURCE:

 [View LT1640AHCS8#PBF on WIN SOURCE](#)

 [Linear Technology](#) Information

Optimize Your Supply Chain with WIN SOURCE Solutions

-  Global Sourcing Solution
-  Obsolete Management
-  Cost Control Management
-  Shortage Management
-  Alternative Solution
-  Excess Inventory Management