



## FEATURES

- Drives External Power MOSFET
- Supply Voltage Range: 4.5V to 20V
- Flyback Voltage Limited Only by External Components
- Senses Output Voltage Directly from Primary Side Winding—No Optoisolator Required
- Switching Frequency from 50kHz to 250kHz with External Capacitor
- Moderate Accuracy Regulation Without User Trims
- Regulation Maintained Well into Discontinuous Mode
- External I<sub>SENSE</sub> Resistor
- Optional Load Compensation
- Optional Undervoltage Lockout
- Shutdown Feature Reduces I<sub>Q</sub> to 50μA Typ
- Available in 16-Pin GN and SO Packages

## APPLICATIONS

- Isolated Flyback Switching Regulators
- Medical Instruments
- Instrumentation Power Supplies

## DESCRIPTION

The LT<sup>®</sup>1737 is a monolithic switching regulator controller specifically designed for the isolated flyback topology. It drives the gate of an external MOSFET and is generally powered from a DC supply voltage. Output voltage feedback information may be supplied by a variety of methods including a third transformer winding, the primary winding or even direct DC feedback (see Applications Information). Its gate drive capability, coupled with a suitable external MOSFET and other power path components, can deliver load power up to tens of Watts.

The LT1737 has a number of features not found on other isolated flyback controller ICs. By utilizing current mode switching techniques, it provides excellent AC and DC line regulation. Its unique control circuitry can maintain regulation well into discontinuous mode in most applications. Optional load compensation circuitry allows for improved load regulation. An optional undervoltage lockout pin halts operation when the application input voltage is too low. An optional external capacitor implements a soft-start function.

LT, LTC and LT are registered trademarks of Linear Technology Corporation. All other trademarks are the property of their respective owners.

## TYPICAL APPLICATION

12V-18V to Isolated 15V Converter

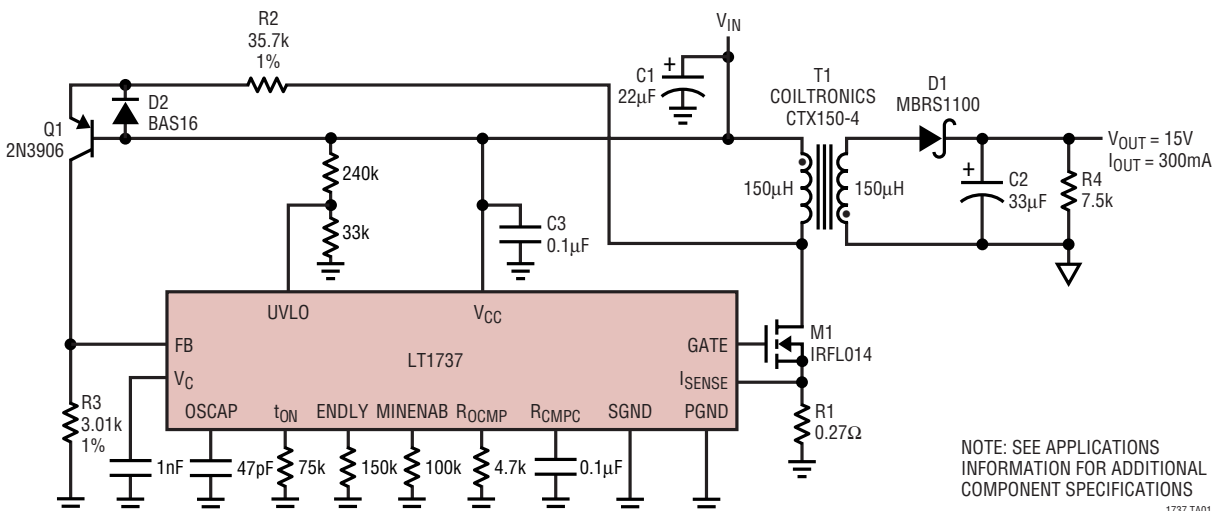

NOTE: SEE APPLICATIONS INFORMATION FOR ADDITIONAL COMPONENT SPECIFICATIONS

1737 TA01

## ABSOLUTE MAXIMUM RATINGS

(Note 1)

$V_{CC}$ Supply Voltage .....	22V
UVLO Pin Voltage .....	$V_{CC}$
$I_{SENSE}$ Pin Voltage .....	2V
FB Pin Current .....	$\pm 2\text{mA}$
Operating Junction Temperature Range	
LT1737C .....	0°C to 100°C
LT1737I .....	-40°C to 125°C
Storage Temperature Range .....	-65°C to 150°C
Lead Temperature (Soldering, 10 sec) .....	300°C

## PACKAGE/ORDER INFORMATION

<p>TOP VIEW</p> <p>GN PACKAGE: 16-LEAD PLASTIC SSOP S PACKAGE: 16-LEAD PLASTIC SO</p> <p><math>T_{JMAX} = 125^{\circ}\text{C}</math>, <math>\theta_{JA} = 110^{\circ}\text{C/W}</math> (GN) <math>T_{JMAX} = 125^{\circ}\text{C}</math>, <math>\theta_{JA} = 110^{\circ}\text{C/W}</math> (SO)</p>	ORDER PART NUMBER
	LT1737CGN LT1737CS LT1737IGN LT1737IS
	GN PART MARKING
	1737 1737I

Consult LTC Marketing for parts specified with wider operating temperature ranges.

## ELECTRICAL CHARACTERISTICS

The ● denotes specifications which apply over the full operating temperature range, otherwise specifications are at  $T_A = 25^{\circ}\text{C}$ .  $V_{CC} = 14\text{V}$ , GATE open,  $V_C = 1.4\text{V}$  unless otherwise noted.

SYMBOL	PARAMETER	CONDITIONS		MIN	TYP	MAX	UNITS
<b>Power Supply</b>							
$V_{CC(MIN)}$	Minimum Input Voltage		●		4.1	4.5	V
$I_{CC}$	Supply Current	$V_C = \text{Open}$	●		10	15	mA
	Shutdown Current	$V_{UVLO} = 0\text{V}$ , $V_C = \text{Open}$	●		50	150	$\mu\text{A}$
<b>Feedback Amplifier</b>							
$V_{FB}$	Feedback Voltage		●	1.230	1.245	1.260	V
				1.220		1.270	V
$I_{FB}$	Feedback Pin Input Current			500			nA
$g_m$	Feedback Amplifier Transconductance	$\Delta I_C = \pm 10\mu\text{A}$	●	400	1000	1800	$\mu\text{mho}$
$I_{SRC}$ , $I_{SNK}$	Feedback Amplifier Source or Sink Current		●	30	50	80	$\mu\text{A}$
$V_{CL}$	Feedback Amplifier Clamp Voltage				2.5		V
	Reference Voltage/Current Line Regulation	$4.75\text{V} \leq V_{IN} \leq 18\text{V}$	●		0.01	0.05	%/V
	Voltage Gain	$V_C = 1\text{V to } 2\text{V}$			2000		V/V
	Soft-Start Charging Current	$V_{SFST} = 0\text{V}$		25	40	50	$\mu\text{A}$
	Soft-Start Discharge Current	$V_{SFST} = 1.5\text{V}$ , $V_{UVLO} = 0\text{V}$		0.8	1.5		mA
<b>Gate Output</b>							
$V_{GATE}$	Output High Level	$I_{GATE} = 100\text{mA}$	●	11.5	12.1		V
		$I_{GATE} = 500\text{mA}$	●	11.0	11.8		V
	Output Low Level	$I_{GATE} = 100\text{mA}$	●		0.3	0.45	V
		$I_{GATE} = 500\text{mA}$	●		0.6	1.0	V
$I_{GATE}$	Output Sink Current in Shutdown, $V_{UVLO} = 0\text{V}$	$V_{GATE} = 2\text{V}$	●	1.2	2.5		mA
$t_r$	Rise Time	$C_L = 1000\text{pF}$			30		ns
$t_f$	Fall Time	$C_L = 1000\text{pF}$			30		ns

**ELECTRICAL CHARACTERISTICS** The ● denotes specifications which apply over the full operating temperature range, otherwise specifications are at  $T_A = 25^\circ\text{C}$ .  $V_{CC} = 14\text{V}$ , GATE open,  $V_C = 1.4\text{V}$  unless otherwise noted.

SYMBOL	PARAMETER	CONDITIONS	MIN	TYP	MAX	UNITS
<b>Current Amplifier</b>						
$V_C$	Control Pin Threshold	Duty Cycle = Min	● 0.90 0.80	1.12	1.25 1.35	V V
$V_{ISENSE}$	Switch Current Limit	Duty Cycle $\leq 30\%$ Duty Cycle $\leq 30\%$ Duty Cycle = 80%	● 220 200	250 220	270 280	mV mV mV
	$\Delta V_{ISENSE}/\Delta V_C$			0.30		mV
<b>Timing</b>						
f	Switching Frequency	$C_{OSCAP} = 100\text{pF}$	● 90 80	100	115 125	kHz kHz
$C_{OSCAP}$	Oscillator Capacitor Value	(Note 2)	33		200	pF
$t_{ON}$	Minimum Switch On Time	$R_{TON} = 50\text{k}$		200		ns
$t_{ED}$	Flyback Enable Delay Time	$R_{ENDLY} = 50\text{k}$		200		ns
$t_{EN}$	Minimum Flyback Enable Time	$R_{MENAB} = 50\text{k}$		200		ns
$R_t$	Timing Resistor Value	(Note 2)	24		240	k $\Omega$
	Maximum Switch Duty Cycle		● 85	90		%
<b>Load Compensation</b>						
	Sense Offset Voltage			2	5	mV
	Current Gain Factor		0.80	0.95	1.05	mV
<b>UVLO Function</b>						
$V_{UVLO}$	UVLO Pin Lockout Threshold		● 1.21	1.25	1.29	V
	UVLO Pin Shutdown Threshold		● 0.4	0.75	0.95	V V
$I_{UVLO}$	UVLO Pin Bias Current	$V_{UVLO} = 1.2\text{V}$ $V_{UVLO} = 1.3\text{V}$	-0.25 -4.50	+0.1 -3.5	+0.25 -2.50	$\mu\text{A}$ $\mu\text{A}$
<b>3V Output Function</b>						
$V_{REF}$	Reference Output Voltage	$I_{LOAD} = 1\text{mA}$	● 2.8	3.0	3.2	V
	Output Impedance			10		$\Omega$
	Current Limit		● 8	15		mA

**Note 1:** Absolute Maximum Ratings are those values beyond which the life of a device may be impaired.

**Note 2:** Component value range guaranteed by design.

# TYPICAL PERFORMANCE CHARACTERISTICS

**Minimum Input Voltage vs Temperature**

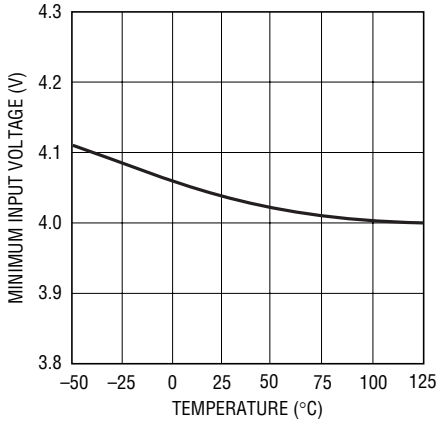

1737 G01

**Shutdown  $I_{CC}$  vs Temperature**

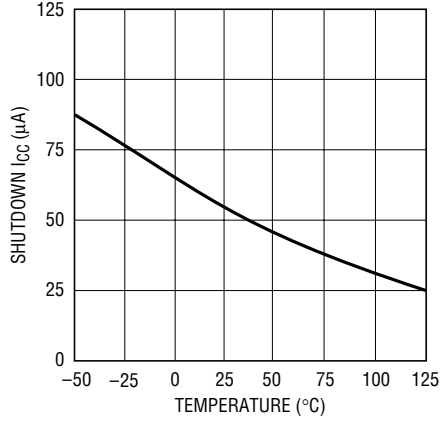

1737 G02

**Shutdown Voltage ( $V_{UVLO}$ ) vs Temperature**

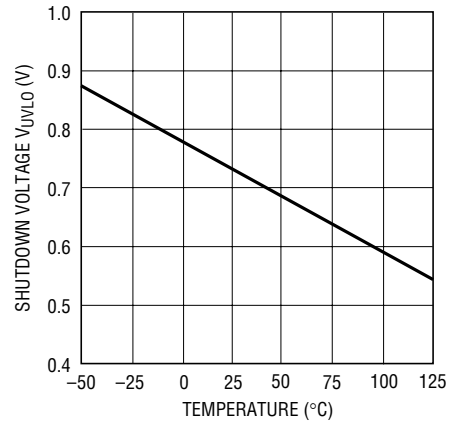

1737 G03

**Supply Current vs Temperature**

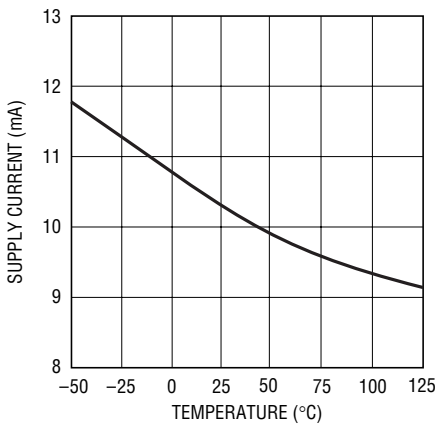

1737 G04

**UVLO Pin Input Current vs Temperature**

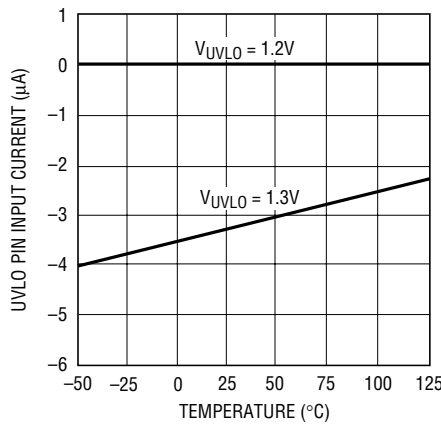

1737 G05

**Oscillator Frequency vs Temperature**

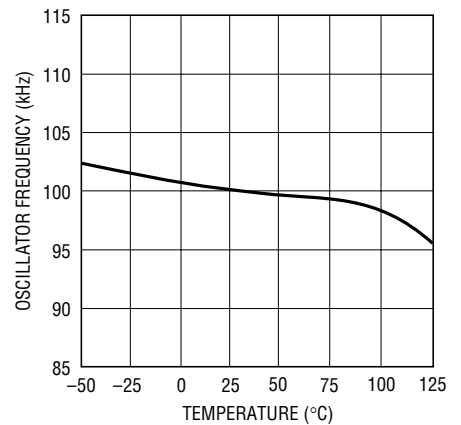

1737 G06

**$V_{GATE}$  vs  $I_{SINK}$**

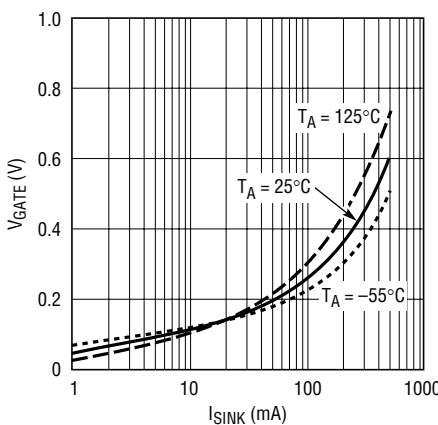

1737 G07

**$V_{CC}-V_{GATE}$  vs  $I_{SOURCE}$**

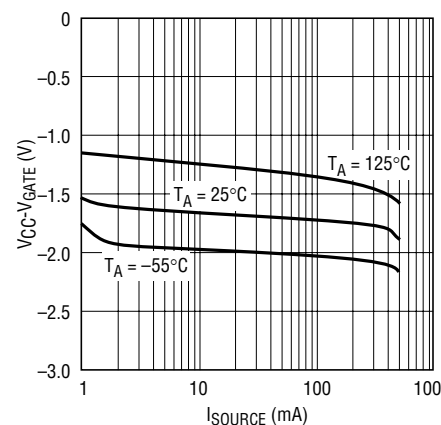

1737 G08

**$V_C$  Clamp Voltage, Switching Threshold vs Temperature**

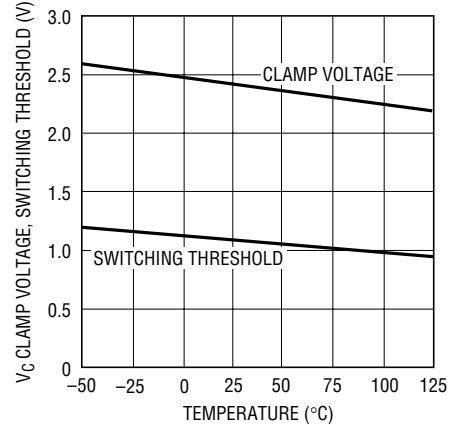

1737 G09

# TYPICAL PERFORMANCE CHARACTERISTICS

**Minimum Switch On Time vs Temperature**

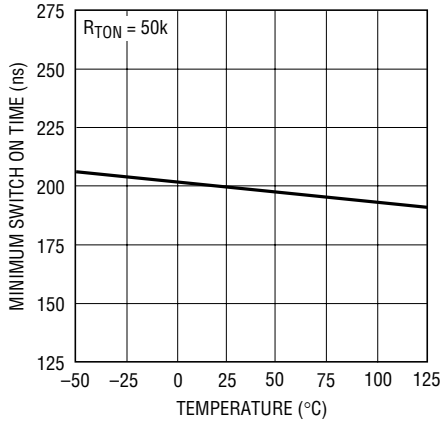

1737 G10

**Minimum Enable Time vs Temperature**

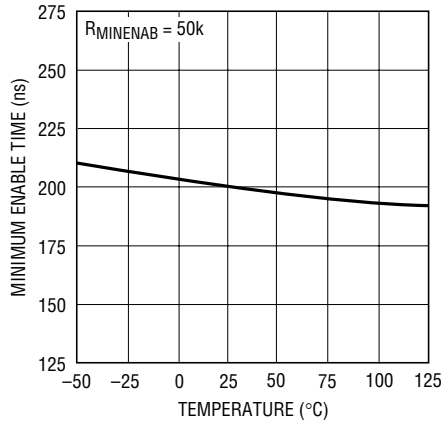

1737 G11

**Enable Delay Time vs Temperature**

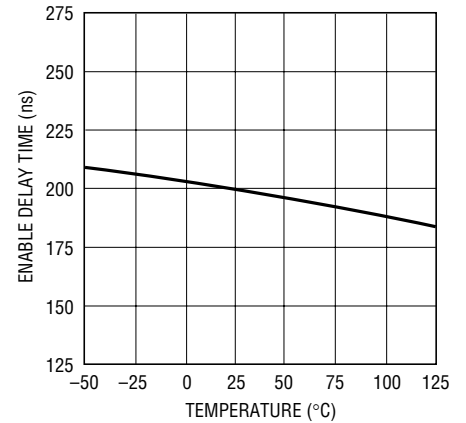

1737 G12

**Feedback Amplifier Output Current vs FB Pin Voltage**

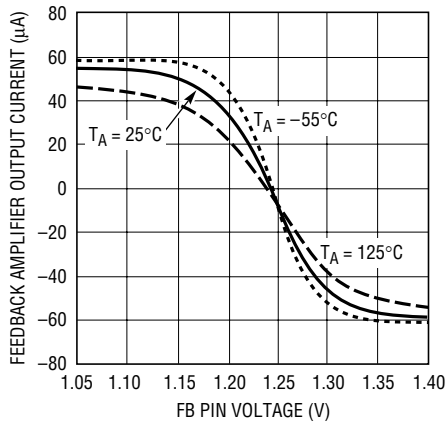

1737 G13

**Feedback Amplifier Transconductance vs Temperature**

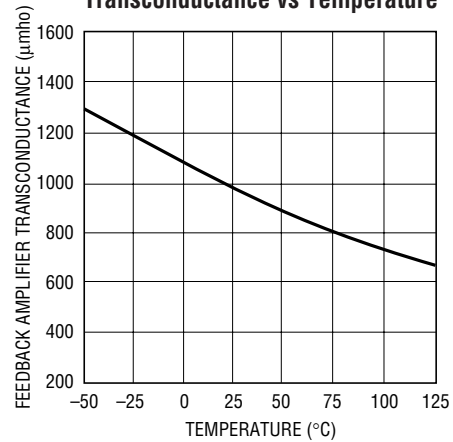

1737 G14

**Soft-Start Charging Current vs Temperature**

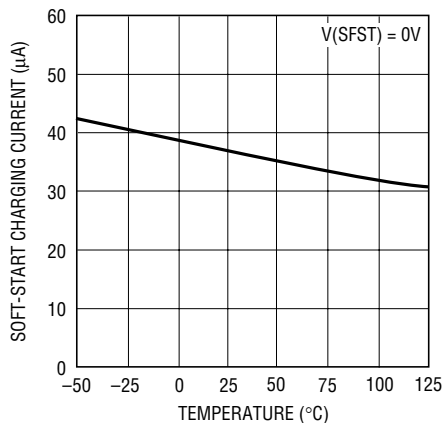

1737 G15

**Soft-Start Sink Current vs Temperature**

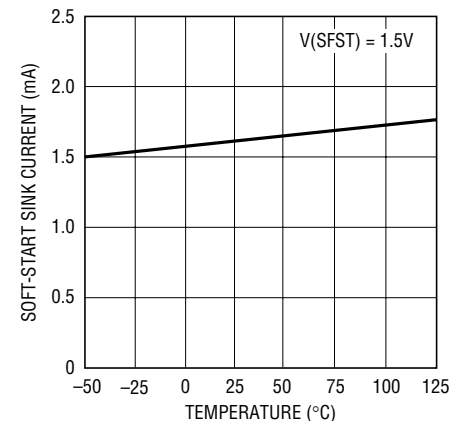

1737 G16

## PIN FUNCTIONS

**PGND (Pin 1):** The power ground pin carries the GATE node discharge current. This is typically a current spike of several hundred mA with a duration of tens of nanoseconds. It should be connected directly to a good quality ground plane.

**I<sub>SENSE</sub> (Pin 2):** Pin to measure switch current with external sense resistor. The sense resistor should be of a noninductive construction as high speed performance is essential. Proper grounding technique is also required to avoid distortion of the high speed current waveform. A preset internal limit of nominally 250mV at this pin effects a switch current limit.

**SFST (Pin 3):** Pin for optional external capacitor to effect soft-start function. See Applications Information for details.

**R<sub>OCMP</sub> (Pin 4):** Input pin for optional external load compensation resistor. Use of this pin allows nominal compensation for nonzero output impedance in the power transformer secondary circuit, including secondary winding impedance, output Schottky diode impedance and output capacitor ESR. In less demanding applications, this resistor is not needed. See Applications Information for more details.

**R<sub>CMPC</sub> (Pin 5):** Pin for external filter capacitor for optional load compensation function. A common 0.1 $\mu$ F ceramic capacitor will suffice for most applications. See Applications Information for further details.

**OSCAP (Pin 6):** Pin for external timing capacitor to set oscillator switching frequency. See Applications Information for details.

**V<sub>C</sub> (pin 7):** This is the control voltage pin which is the output of the feedback amplifier and the input of the current comparator. Frequency compensation of the overall loop is effected in most cases by placing a capacitor between this node and ground.

**FB (Pin 8):** Input pin for external “feedback” resistor divider. The ratio of this divider, times the internal band-gap ( $V_{BG}$ ) reference, times the effective transformer turns ratio is the primary determinant of the output voltage. The Thevenin equivalent resistance of the feedback divider should be roughly 3k. See Applications Information for more details.

**3V<sub>OUT</sub> (Pin 9):** Output pin for nominal 3V reference. This facilitates various user applications. This node is internally current limited for protection and is intended to drive either moderate capacitive loads of several hundred pF or less, or, very large capacitive loads of 0.1 $\mu$ F or more. See Applications Information for more details.

**UVLO (Pin 10):** This is a dual function pin that implements both undervoltage lockout and shutdown functions. Pulling this pin to near ground effects shutdown and reduces quiescent current to tens of microamperes.

Additionally, an external resistor divider between  $V_{IN}$  and ground may be connected to this pin to implement an undervoltage lockout function. The bias current on this pin is a function of the state of the UVLO comparator; as the threshold is exceeded, the bias current increases. This creates a hysteresis band equal to the change in bias current times the Thevenin impedance of the user’s resistive divider. The user may thereby adjust the impedance of the UVLO divider to achieve a desired degree of hysteresis. A 100pF capacitor to ground is recommended on this pin. See Application Information for details.

**SGND (Pin 11):** The signal ground pin is a clean ground. The internal reference, oscillator and feedback amplifier are referred to it. Keep the ground path connection to the FB pin, OSCAP capacitor and the  $V_C$  compensation capacitor free of large ground currents.

**MINENAB (Pin 12):** Pin for external programming resistor to set minimum enable time. See Applications Information for details.

**ENDLY (Pin 13):** Pin for external programming resistor to set enable delay time. See Applications Information for details.

**t<sub>ON</sub> (Pin 14):** Pin for external programming resistor to set switch minimum on time. See Applications Information for details.

**V<sub>CC</sub> (Pin 15):** Supply voltage for the LT1737. Bypass this pin to ground with 1 $\mu$ F or more.

**GATE (Pin 16):** This is the gate drive to the external power MOSFET switch and has large dynamic currents flowing through it. Keep the trace to the MOSFET as short as possible to minimize electromagnetic radiation and voltage spikes. A series resistance of 5 $\Omega$  or more may help to dampen ringing in less than ideal layouts.

# BLOCK DIAGRAM

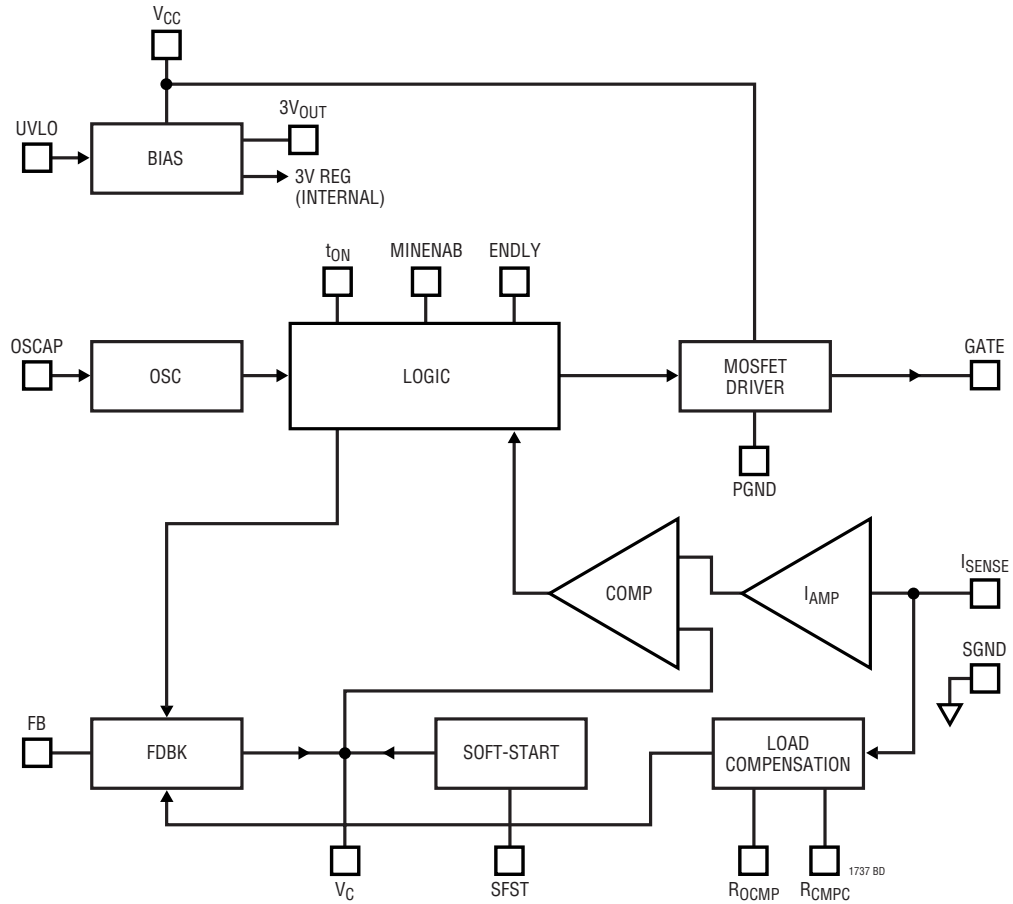

# TIMING DIAGRAM

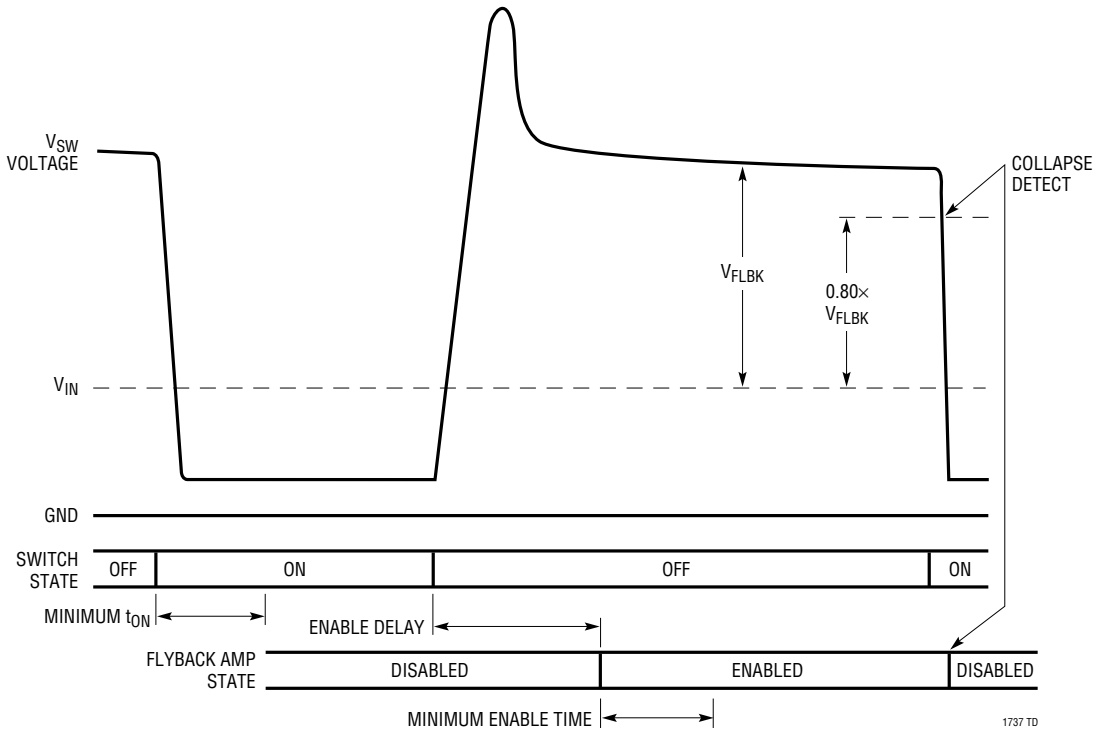

# FLYBACK ERROR AMPLIFIER

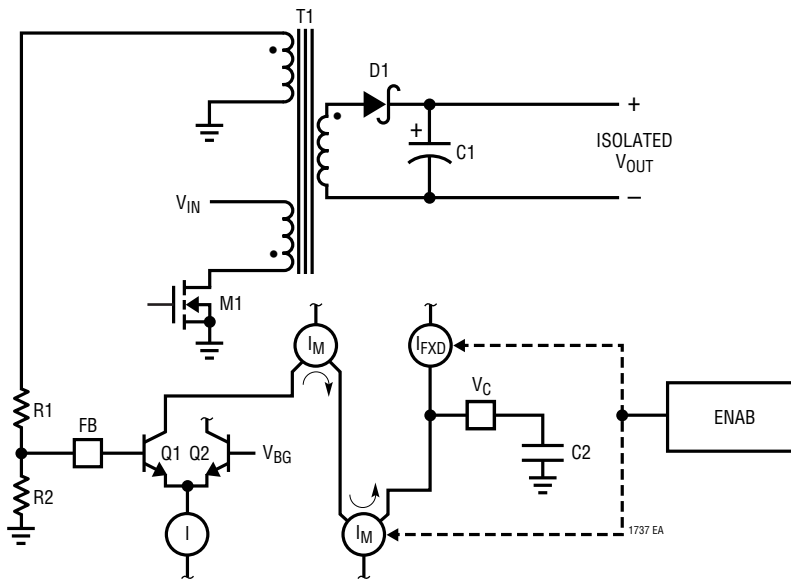

## OPERATION

The LT1737 is a current mode switcher controller IC designed specifically for the isolated flyback topology. The Block Diagram shows an overall view of the system. Many of the blocks are similar to those found in traditional designs, including: Internal Bias Regulator, Oscillator, Logic, Current Amplifier and Comparator, Driver and Output Switch. The novel sections include a special Flyback Error Amplifier and a Load Compensation mechanism. Also, due to the special dynamic requirements of flyback control, the Logic system contains additional functionality not found in conventional designs.

The LT1737 operates much the same as traditional current mode switchers, the major difference being a different type of error amplifier that derives its feedback information from the flyback pulse. Due to space constraints, this discussion will not reiterate the basics of current mode switcher/controllers and isolated flyback converters. A good source of information on these topics is Application Note AN19.

### ERROR AMPLIFIER—PSEUDO DC THEORY

Please refer to the simplified diagram of the Flyback Error Amplifier. Operation is as follows: when MOSFET output switch M1 turns off, its drain voltage rises above the  $V_{IN}$  rail. The amplitude of this flyback pulse as seen on the third winding is given as:

$$V_{FLBK} = \frac{(V_{OUT} + V_F + I_{SEC} \cdot ESR)}{N_{ST}}$$

$V_F$  = D1 forward voltage

$I_{SEC}$  = transformer secondary current

ESR = total impedance of secondary circuit

$N_{ST}$  = transformer effective secondary-to-third winding turns ratio

The flyback voltage is then scaled by external resistor divider R1/R2 and presented at the FB pin. This is then compared to the internal bandgap reference by the differential transistor pair Q1/Q2. The collector current from Q1 is mirrored around and subtracted from fixed current source  $I_{FXD}$  at the  $V_C$  pin. An external capacitor integrates this net current to provide the control voltage to set the current mode trip point.

The relatively high gain in the overall loop will then cause the voltage at the FB pin to be nearly equal to the bandgap reference  $V_{BG}$ . The relationship between  $V_{FLBK}$  and  $V_{BG}$  may then be expressed as:

$$V_{FLBK} = \frac{(R1 + R2)}{R2} V_{BG}$$

Combination with the previous  $V_{FLBK}$  expression yields an expression for  $V_{OUT}$  in terms of the internal reference, programming resistors, transformer turns ratio and diode forward voltage drop:

$$V_{OUT} = V_{BG} \frac{(R1 + R2)}{R2} \left( \frac{1}{N_{ST}} \right) - V_F - I_{SEC} \cdot ESR$$

Additionally, it includes the effect of nonzero secondary output impedance, which is discussed in further detail, see Load Compensation Theory. The practical aspects of applying this equation for  $V_{OUT}$  are found in the Applications Information section.

So far, this has been a pseudo-DC treatment of flyback error amplifier operation. But the flyback signal is a pulse, not a DC level. Provision must be made to enable the flyback amplifier only when the flyback pulse is present. This is accomplished by the dotted line connections to the block labeled "ENAB". Timing signals are then required to enable and disable the flyback amplifier.

### ERROR AMPLIFIER—DYNAMIC THEORY

There are several timing signals that are required for proper LT1737 operation. Please refer to the Timing Diagram.

### Minimum Output Switch On Time

The LT1737 effects output voltage regulation via flyback pulse action. If the output switch is not turned on at all, there will be no flyback pulse and output voltage information is no longer available. This would cause irregular loop response and start-up/latchup problems. The solution chosen is to require the output switch to be on for an absolute minimum time per each oscillator cycle. This in turn establishes a minimum load requirement to maintain regulation. See Applications Information for further details.

## OPERATION

### Enable Delay

When the output switch shuts off, the flyback pulse appears. However, it takes a finite time until the transformer primary side voltage waveform approximately represents the output voltage. This is partly due to finite rise time on the MOSFET drain node, but more importantly, due to transformer leakage inductance. The latter causes a voltage spike on the primary side not directly related to output voltage. (Some time is also required for internal settling of the feedback amplifier circuitry.)

In order to maintain immunity to these phenomena, a fixed delay is introduced between the switch turnoff command and the enabling of the feedback amplifier. This is termed enable delay. In certain cases where the leakage spike is not sufficiently settled by the end of the enable delay period, regulation error may result. See Application Information for further details.

### Collapse Detect

Once the feedback amplifier is enabled, some mechanism is then required to disable it. This is accomplished by a collapse detect comparator, which compares the flyback voltage (FB referred) to a fixed reference, nominally 80% of  $V_{BG}$ . When the flyback waveform drops below this level, the feedback amplifier is disabled. This action accommodates both continuous and discontinuous mode operation.

### Minimum Enable Time

The feedback amplifier, once enabled, stays enabled for a fixed minimum time period termed “minimum enable time.” This prevents lockup, especially when the output voltage is abnormally low, e.g., during start-up. The minimum enable time period ensures that the  $V_C$  node is able to “pump up” and increase the current mode trip point to the level where the collapse detect system exhibits proper operation. The “minimum enable time” often determines the low load level at which output voltage regulation is lost. See Applications Information for details.

### Effects of Variable Enable Period

It should now be clear that the flyback amplifier is enabled during only a portion of the cycle time. This can vary from the fixed “minimum enable time” described to a maximum of roughly the “off” switch time minus the enable delay time. Certain parameters of flyback amp behavior will then be directly affected by the variable enable period. These include effective transconductance and  $V_C$  node slew rate.

### LOAD COMPENSATION THEORY

The LT1737 uses the flyback pulse to obtain information about the isolated output voltage. A potential error source is caused by transformer secondary current flow through the real life nonzero impedances of the output rectifier,

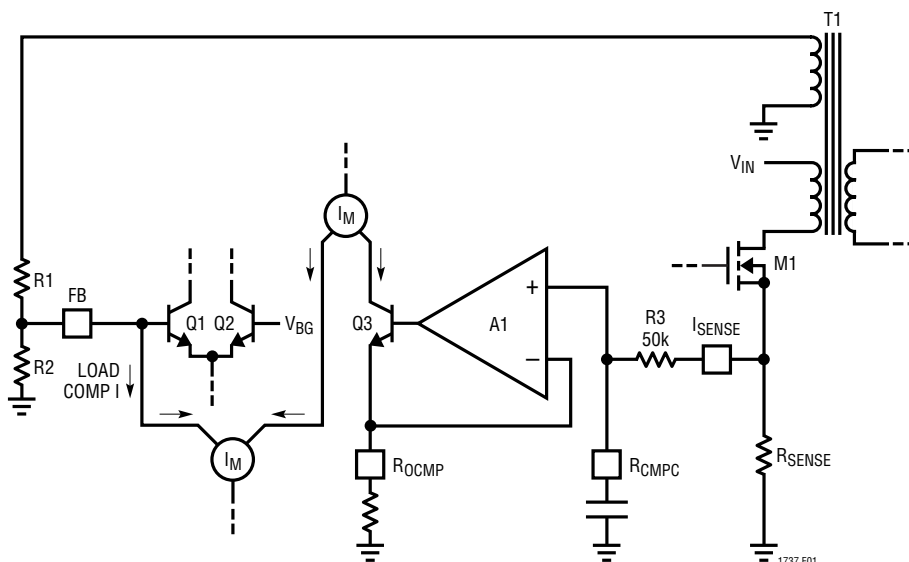

Figure 1. Load Compensation Diagram

## OPERATION

transformer secondary and output capacitor. This has been represented previously by the expression “ $I_{SEC} \cdot ESR$ .” However, it is generally more useful to convert this expression to an effective output impedance. Because the secondary current only flows during the off portion of the duty cycle, the effective output impedance equals the lumped secondary impedance times the inverse of the OFF duty cycle. That is:

$$R_{OUT} = ESR \left( \frac{1}{DC_{OFF}} \right) \text{ where}$$

$R_{OUT}$  = effective supply output impedance

$ESR$  = lumped secondary impedance

$DC_{OFF}$  = OFF duty cycle

Expressing this in terms of the ON duty cycle, remembering  $DC_{OFF} = 1 - DC$ ,

$$R_{OUT} = ESR \left( \frac{1}{1-DC} \right)$$

$DC$  = ON duty cycle

In less critical applications, or if output load current remains relatively constant, this output impedance error may be judged acceptable and the external FB resistor divider adjusted to compensate for nominal expected error. In more demanding applications, output impedance error may be minimized by the use of the load compensation function.

To implement the load compensation function, a voltage is developed that is proportional to average output switch current. This voltage is then impressed across the external  $R_{OCMP}$  resistor, and the resulting current acts to decrease the voltage at the FB pin. As output loading increases, average switch current increases to maintain rough output voltage regulation. This causes an increase in  $R_{OCMP}$  resistor current which effects a corresponding increase in flyback voltage amplitude.

Assuming a relatively fixed power supply efficiency,  $Eff$ ,

$$\text{Power Out} = Eff \cdot \text{Power In}$$

$$V_{OUT} \cdot I_{OUT} = Eff \cdot V_{IN} \cdot I_{IN}$$

Average primary side current may be expressed in terms of output current as follows:

$$I_{IN} = \left( \frac{V_{OUT}}{V_{IN} \cdot Eff} \right) \cdot I_{OUT}$$

combining the efficiency and voltage terms in a single variable:

$$I_{IN} = K1 \cdot I_{OUT}, \text{ where}$$

$$K1 = \left( \frac{V_{OUT}}{V_{IN} \cdot Eff} \right)$$

Switch current is converted to voltage by the external sense resistor and averaged/lowpass filtered by  $R3$  and the external capacitor on  $R_{CMPC}$ . This voltage is then impressed across the external  $R_{OCMP}$  resistor by op amp  $A1$  and transistor  $Q3$ . This produces a current at the collector of  $Q3$  which is then mirrored around and then subtracted from the FB node. This action effectively increases the voltage required at the top of the  $R1/R2$  feedback divider to achieve equilibrium. So the effective change in  $V_{OUT}$  target is:

$$\Delta V_{OUT} = (K1 \cdot \Delta I_{OUT}) \left( \frac{R_{SENSE}}{R_{OCMP}} \right) \cdot (R1 || R2) \text{ or}$$

$$\frac{\Delta V_{OUT}}{\Delta I_{OUT}} = K1 \left( \frac{R_{SENSE}}{R_{OCMP}} \right) \cdot (R1 || R2)$$

Nominal output impedance cancellation is obtained by equating this expression with  $R_{OUT}$ :

$$R_{OUT} = K1 \left( \frac{R_{SENSE}}{R_{OCMP}} \right) \cdot (R1 || R2) \text{ and}$$

$$R_{OCMP} = K1 \left( \frac{R_{SENSE}}{R_{OUT}} \right) \cdot (R1 || R2) \text{ where}$$

$K1$  = dimensionless variable related to  $V_{IN}$ ,  $V_{OUT}$  and efficiency as above

$R_{SENSE}$  = external sense resistor

$R_{OUT}$  = uncompensated output impedance

$(R1 || R2)$  = impedance of  $R1$  and  $R2$  in parallel

The practical aspects of applying this equation to determine an appropriate value for the  $R_{OCMP}$  resistor are found in the Applications Information section.

## APPLICATIONS INFORMATION

### TRANSFORMER DESIGN CONSIDERATIONS

Transformer specification and design is perhaps the most critical part of applying the LT1737 successfully. In addition to the usual list of caveats dealing with high frequency isolated power supply transformer design, the following information should prove useful.

#### Turns Ratios

Note that due to the use of the external feedback resistor divider ratio to set output voltage, the user has relative freedom in selecting transformer turns ratio to suit a given application. In other words, “screwball” turns ratios like “1.736:1.0” can scrupulously be avoided! In contrast, simpler ratios of small integers, e.g., 1:1, 2:1, 3:2, etc. can be employed which yield more freedom in setting total turns and mutual inductance. Turns ratio can then be chosen on the basis of desired duty cycle. However, remember that the input supply voltage plus the secondary-to-primary referred version of the flyback pulse (including leakage spike) must not exceed the allowed external MOSFET breakdown rating.

#### Leakage Inductance

Transformer leakage inductance (on either the primary or secondary) causes a spike after output switch turnoff. This is increasingly prominent at higher load currents, where more stored energy must be dissipated. In many cases a “snubber” circuit will be required to avoid overvoltage breakdown at the output switch node. Application Note AN19 is a good reference on snubber design.

In situations where the flyback pulse extends beyond the enable delay time, the output voltage regulation will be affected to some degree. It is important to realize that the feedback system has a deliberately limited input range, roughly  $\pm 50\text{mV}$  referred to the FB node, and this works to the user’s advantage in rejecting large, i.e., higher voltage, leakage spikes. In other words, once a leakage spike is several volts in amplitude, a further increase in amplitude has little effect on the feedback system. So the user is generally advised to arrange the snubber circuit to clamp at as high a voltage as comfortably possible, observing MOSFET breakdown, such that leakage spike duration is as short as possible.

As a rough guide, total leakage inductances of several percent (of mutual inductance) or less may require a snubber, but exhibit little to no regulation error due to leakage spike behavior. Inductances from several percent up to perhaps ten percent cause increasing regulation error.

Severe leakage inductances in the double digit percentage range should be avoided if at all possible as there is a potential for abrupt loss of control at high load current. This curious condition potentially occurs when the leakage spike becomes such a large portion of the flyback waveform that the processing circuitry is fooled into thinking that the leakage spike itself is the real flyback signal! It then reverts to a potentially stable state whereby the top of the leakage spike is the control point, and the trailing edge of the leakage spike triggers the collapse detect circuitry. This will typically reduce the output voltage abruptly to a fraction, perhaps between one-third to two-thirds of its correct value. If load current is reduced sufficiently, the system will snap back to normal operation. When using transformers with considerable leakage inductance, it is important to exercise this worst-case check for potential bistability:

1. Operate the prototype supply at maximum expected load current.
2. Temporarily short circuit the output.
3. Observe that normal operation is restored.

If the output voltage is found to hang up at an abnormally low value, the system has a problem. This will usually be evident by simultaneously monitoring the  $V_{SW}$  waveform on an oscilloscope to observe leakage spike behavior firsthand. A final note—the susceptibility of the system to bistable behavior is somewhat a function of the load I/V characteristics. A load with resistive, i.e.,  $I = V/R$  behavior is the most susceptible to bistability. Loads which exhibit “CMOSsy”, i.e.,  $I = V^2/R$  behavior are less susceptible.

#### Secondary Leakage Inductance

In addition to the previously described effects of leakage inductance in general, leakage inductance on the secondary in particular exhibits an additional phenomenon. It forms an inductive divider on the transformer secondary,

## APPLICATIONS INFORMATION

which reduces the size of the primary-referred flyback pulse used for feedback. This will increase the output voltage target by a similar percentage. Note that unlike leakage *spike* behavior, this phenomena is load independent. To the extent that the secondary leakage inductance is a constant percentage of mutual inductance (over manufacturing variations), this can be accommodated by adjusting the feedback resistor divider ratio.

### Winding Resistance Effects

Resistance in either the primary or secondary will act to reduce overall efficiency ( $P_{OUT}/P_{IN}$ ). Resistance in the secondary increases effective output impedance which degrades load regulation, (at least before load compensation is employed).

### Bifilar Winding

A bifilar or similar winding technique is a good way to minimize troublesome leakage inductances. However, remember that this will increase primary-to-secondary capacitance and limit the primary-to-secondary breakdown voltage, so bifilar winding is not always practical.

Finally, the LTC Applications group is available to assist in the choice and/or design of the transformer. Happy Winding!

### SELECTING FEEDBACK RESISTOR DIVIDER VALUES

The expression for  $V_{OUT}$  developed in the Operation section can be rearranged to yield the following expression for the R1/R2 ratio:

$$\frac{(R1+R2)}{R2} = \frac{(V_{OUT} + V_F + I_{SEC} \cdot ESR)}{V_{BG}} N_{ST} \text{ where:}$$

$V_{OUT}$  = desired output voltage

$V_F$  = switching diode forward voltage

$I_{SEC} \cdot ESR$  = secondary resistive losses

$V_{BG}$  = data sheet reference voltage value

$N_{ST}$  = effective secondary-to-third winding turns ratio

The above equation defines only the ratio of R1 to R2, not their individual values. However, a “second equation for

two unknowns” is obtained from noting that the Thevenin impedance of the resistor divider should be roughly 3k for bias current cancellation and other reasons.

### SELECTING $R_{OCMP}$ RESISTOR VALUE

The Operation section previously derived the following expressions for  $R_{OUT}$ , i.e., effective output impedance and  $R_{OCMP}$ , the external resistor value required for its nominal compensation:

$$R_{OUT} = ESR \left( \frac{1}{1-DC} \right)$$

$$R_{OCMP} = K1 \left( \frac{R_{SENSE}}{R_{OUT}} \right) (R1 || R2)$$

While the value for  $R_{OCMP}$  may therefore be theoretically determined, it is usually better in practice to employ empirical methods. This is because several of the required input variables are difficult to estimate precisely. For instance, the ESR term above includes that of the transformer secondary, but its effective ESR value depends on high frequency behavior, not simply DC winding resistance. Similarly, K1 appears to be a simple ratio of  $V_{IN}$  to  $V_{OUT}$  times (differential) efficiency, but theoretically estimating efficiency is not a simple calculation. The suggested empirical method is as follows:

Build a prototype of the desired supply using the eventual secondary components. Temporarily ground the  $R_{CMPC}$  pin to disable the load compensation function. Operate the supply over the expected range of output current loading while measuring the output voltage deviation. Approximate this variation as a single value of  $R_{OUT}$  (straight line approximation). Calculate a value for the K1 constant based on  $V_{IN}$ ,  $V_{OUT}$  and the measured (differential) efficiency. These are then combined with  $R_{SENSE}$  as indicated to yield a value for  $R_{OCMP}$ .

Verify this result by connecting a resistor of roughly this value from the  $R_{OCMP}$  pin to ground. (Disconnect the ground short to  $R_{CMPC}$  and connect the requisite 0.1 $\mu$ F filter capacitor to ground.) Measure the output impedance with the new compensation in place. Modify the original  $R_{OCMP}$  value if necessary to increase or decrease the effective compensation.

## APPLICATIONS INFORMATION

### SELECTING OSCILLATOR CAPACITOR VALUE

The switching frequency of the LT1737 is set by an external capacitor connected between the OSCAP pin and ground. Recommended values are between 200pF and 33pF, yielding switching frequencies between 50kHz and 250kHz. Figure 2 shows the nominal relationship between external capacitance and switching frequency. To minimize stray capacitance and potential noise pickup, this capacitor should be placed as close as possible to the IC and the OSCAP node length/area minimized.

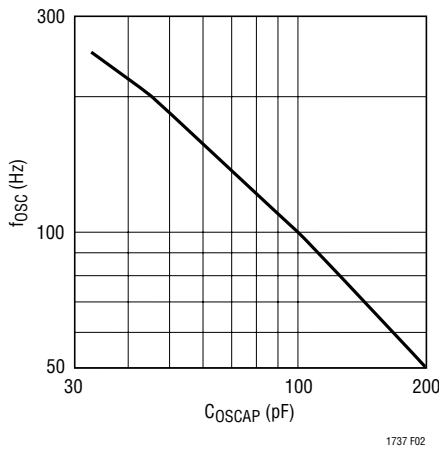

Figure 2. f<sub>osc</sub> vs OSCAP Value

### SELECTING TIMING RESISTOR VALUES

There are three internal “one-shot” times that are programmed by external application resistors: minimum on time, enable delay time and minimum enable time. These are all part of the isolated flyback control technique, and their functions have been previously outlined in the Operation section. Figure 3 shows nominal observed time versus external resistor value for these functions.

The following information should help in selecting and/or optimizing these timing values.

#### Minimum On Time

This time defines a period whereby the normal switch current limit is ignored. This feature provides immunity to the leading edge current spike often seen at the source node of the external power MOSFET, due to rapid charging of its gate/source capacitance. This current spike is not

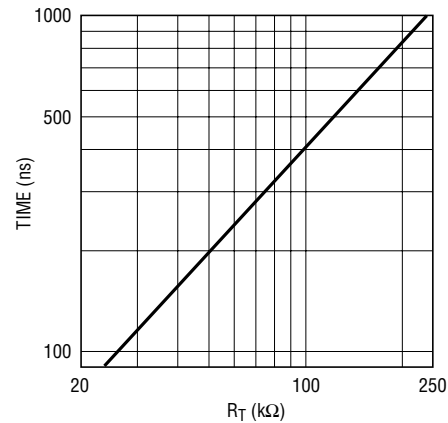

Figure 3. “One Shot” Times vs Programming Resistor

indicative of actual current level in the transformer primary, and may cause irregular current mode switching action, especially at light load.

However, the user must remember that the LT1737 does not “skip cycles” at light loads. Therefore, minimum on time will set a limit on minimum delivered power and consequently a minimum load requirement to maintain regulation (see Minimum Load Considerations). Similarly, minimum on time has a direct effect on short-circuit behavior (see Maximum Load/Short-Circuit Considerations).

The user is normally tempted to set the minimum on time to be short to minimize these load related consequences. (After all, a smaller minimum on time approaches the ideal case of zero, or no minimum.) However, a longer time may be required in certain applications based on MOSFET switching current spike considerations.

#### Enable Delay Time

This function provides a programmed delay between turnoff of the gate drive node and the subsequent enabling of the feedback amplifier. At high loads, a primary side voltage spike after MOSFET turnoff may be observed due to transformer leakage inductance. This spike is not indicative of actual output voltage (see Figure 4B). Delaying the enabling of the feedback amplifier allows this system to effectively ignore most or all of the voltage spike and maintain proper output voltage regulation. The enable delay time should therefore be set to the maximum expected duration of the leakage spike. This may have

## APPLICATIONS INFORMATION

implications regarding output voltage regulation at minimum load (see Minimum Load Considerations).

A second benefit of the enable delay time function occurs at light load. Under such conditions the amount of energy stored in the transformer is small. The flyback waveform becomes “lazy” and some time elapses before it indicates the actual secondary output voltage (see Figure 4C). So the enable delay time should also be set long enough to ignore the “irrelevant” portion of the flyback waveform at light load.

Additionally, there are cases wherein the gate output is called upon to drive a large geometry MOSFET such that the turnoff transition is slowed significantly. Under such circumstances, the enable delay time may be increased to accommodate for the lengthy transition.

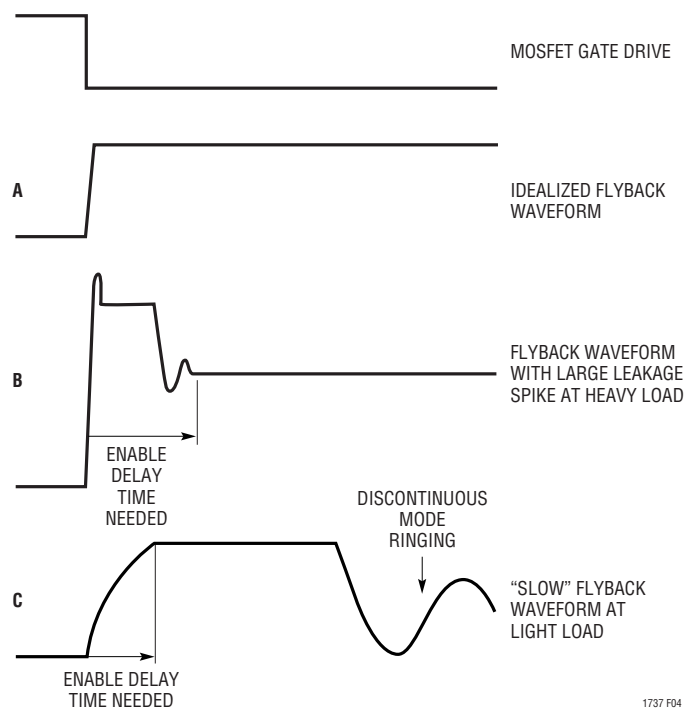

Figure 4

### Minimum Enable Time

This function sets a minimum duration for the expected flyback pulse. Its primary purpose is to provide a minimum source current at the  $V_C$  node to avoid start-up problems.

Average “start-up”  $V_C$  current =

$$\frac{\text{Minimum Enable Time}}{\text{Switching Frequency}} \cdot I_{\text{SRC}}$$

Minimum enable time can also have implications at light load (see Minimum Load Considerations). The temptation is to set the minimum enable time to be fairly short, as this is the least restrictive in terms of minimum load behavior. However, to provide a “reliable” minimum start-up current of say, nominally  $1\mu\text{A}$ , the user should set the minimum enable time at no less than 2% of the switching period ( $= 1/\text{switching frequency}$ ).

### CURRENT SENSE RESISTOR CONSIDERATIONS

The external current sense resistor allows the user to optimize the current limit behavior for the particular application under consideration. As the current sense resistor is varied from several ohms down to tens of milliohms, peak switch current goes from a fraction of an ampere to tens of amperes. Care must be taken to ensure proper circuit operation, especially with small current sense resistor values.

For example, a peak switch current of 10A requires a sense resistor of  $0.025\Omega$ . Note that the instantaneous peak power in the sense resistor is 2.5W, and it must be rated accordingly. The LT1737 has only a single sense line to this resistor. Therefore, any parasitic resistance in the ground side connection of the sense resistor will increase its apparent value. In the case of a  $0.025\Omega$  sense resistor, *one milliohm* of parasitic resistance will cause a 4% reduction in peak switch current. So resistance of printed circuit copper traces and vias cannot necessarily be ignored.

An additional consideration is parasitic inductance. Inductance in series with the current sense resistor will accentuate the high frequency components of the current waveform. In particular, the gate switching spike and multimegahertz ringing at the MOSFET can be considerably amplified. If severe enough, this can cause erratic operation. For example, assume 3nH of parasitic inductance (equivalent to about 0.1 inch of wire in free space) is in series with an ideal  $0.025\Omega$  sense resistor. A “zero” will be formed at  $f = R/(2\pi L)$ , or 1.3MHz. Above

## APPLICATIONS INFORMATION

this frequency the sense resistor will behave like an inductor.

Several techniques can be used to tame this potential parasitic inductance problem. First, any resistor used for current sensing purposes must be of an inherently non-inductive construction. Mounting this resistor directly above an unbroken ground plane and minimizing its ground side connection will serve to absolutely minimize parasitic inductance. In the case of low valued sense resistors, these may be implemented as a parallel combination of several resistors for the thermal considerations cited above. The parallel combination will help to lower the parasitic inductance. Finally, it may be necessary to place a “pole” between the current sense resistor and the LT1737 I<sub>SENSE</sub> pin to undo the action of the inductive zero (see Figure 5). A value of 51Ω is suggested for the resistor, while the capacitor is selected empirically for the particular application and layout. Using good high frequency measurement techniques, the I<sub>SENSE</sub> pin waveform may be observed directly with an oscilloscope while the capacitor value is varied.

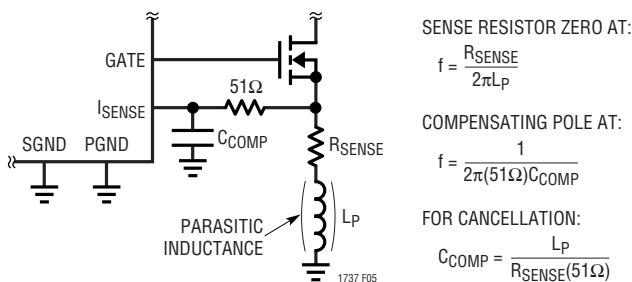

Figure 5

### SOFT-START FUNCTION

The LT1737 contains an optional soft-start function that is enabled by connecting an explicit external capacitor between the SFST pin and ground. Internal circuitry prevents the control voltage at the V<sub>C</sub> pin from exceeding that on the SFST pin.

The soft-start function is engaged whenever V<sub>CC</sub> power is removed, or as a result of either undervoltage lockout or thermal (overtemperature) shutdown. The SFST node is then discharged rapidly to roughly a V<sub>BE</sub> above ground. (Remember that the V<sub>C</sub> pin control node switching

threshold is deliberately set at a V<sub>BE</sub> plus several hundred millivolts.) When this condition is removed, a nominal 40μA current acts to charge up the SFST node towards roughly 3V. So, for example, a 0.1μF soft-start capacitor will place a 0.4V/ms limit on the ramp rate at the V<sub>C</sub> node.

### UVLO PIN FUNCTION

The UVLO pin effects both undervoltage lockout and shutdown functions. This is accomplished by using different voltage thresholds for the two functions—the shutdown function is at roughly a V<sub>BE</sub> above ground (0.75V at 25°C, large temperature variation), while the UVLO function is at nearly a bandgap voltage (1.25V, fairly stable with temperature). An external resistor divider between the input supply and ground can then be used to achieve a user-programmable undervoltage lockout (see Figure 6a).

An additional feature of this pin is that there is a change in the input bias current at this pin as a function of the state of the internal UVLO comparator. As the pin is brought above the UVLO threshold, the bias current sourced by the part increases. This positive feedback effects a hysteresis band for reliable switching action. Note that the size of the hysteresis is proportional to the Thevenin impedance of the external UVLO resistor divider network, which makes it user programmable. As a rough rule of thumb, each 4k or so of impedance generates about 1% of hysteresis. (This is based on roughly 1.25V for the threshold and 3μA for the bias current shift.)

Even in good quality ground plane layouts, it is common for the switching node (MOSFET drain) to couple to the UVLO pin with a stray capacitance of several *thousandths* of a pF. To ensure proper UVLO action, a 100pF capacitor is recommended from this pin to ground as shown in Figure 6b. This will typically reduce the coupled noise to a few millivolts. The UVLO filter capacitor should not be made much larger than a few hundred pF, however, as the hysteresis action will become too slow. In cases where further filtering is required, e.g., to attenuate high speed supply ripple, the topology in Figure 6c is recommended. Resistor R1 has been split into two equal parts. This provides a node for effecting capacitor filtering of high speed supply ripple, while leaving the UVLO pin node impedance relatively unchanged at high frequency.

## APPLICATIONS INFORMATION

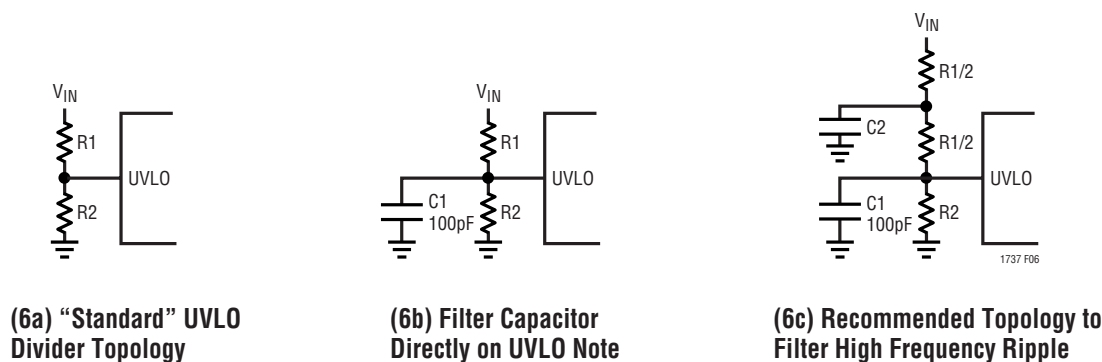

Figure 6

### FREQUENCY COMPENSATION

Loop frequency compensation is performed by connecting a capacitor from the output of the error amplifier ( $V_C$  pin) to ground. An additional series resistor, often required in traditional current mode switcher controllers, is usually not required and can even prove detrimental. The phase margin improvement traditionally offered by this extra resistor will usually be already accomplished by the nonzero secondary circuit impedance, which adds a “zero” to the loop response.

In further contrast to traditional current mode switchers,  $V_C$  pin ripple is generally not an issue with the LT1737. The dynamic nature of the clamped feedback amplifier forms an effective track/hold type response, whereby the  $V_C$  voltage changes during the flyback pulse, but is then “held” during the subsequent “switch on” portion of the next cycle. This action naturally holds the  $V_C$  voltage stable during the current comparator sense action (current mode switching).

### OUTPUT VOLTAGE ERROR SOURCES

Conventional nonisolated switching power supply ICs typically have only two substantial sources of output voltage error: the internal or external resistor divider network that connects to  $V_{OUT}$  and the internal IC reference. The LT1737, which senses the output voltage in both a dynamic and an isolated manner, exhibits additional potential error sources to contend with. Some of these errors are proportional to output voltage, others are fixed in an absolute millivolt sense. Here is a list of possible error sources and their effective contribution.

### Internal Voltage Reference

The internal bandgap voltage reference is, of course, imperfect. Its error, both at 25°C and over temperature is already included in the specifications.

### User Programming Resistors

Output voltage is controlled by the user-supplied feedback resistor divider ratio. To the extent that the resistor ratio differs from the ideal value, the output voltage will be proportionally affected. Highest accuracy systems will demand 1% components.

### Schottky Diode Drop

The LT1737 senses the output voltage from the transformer primary side during the flyback portion of the cycle. This sensed voltage therefore includes the forward drop,  $V_F$ , of the rectifier (usually a Schottky diode). The nominal  $V_F$  of this diode should therefore be included in feedback resistor divider calculations. Lot to lot and ambient temperature variations will show up as output voltage shift/drift.

### Secondary Leakage Inductance

Leakage inductance on the transformer secondary reduces the effective secondary-to-third winding turns ratio ( $N_S/N_T$ ) from its ideal value. This will increase the output voltage target by a similar percentage. To the extent that secondary leakage inductance is constant from part to part, this can be accommodated by adjusting the feedback resistor ratio.

## APPLICATIONS INFORMATION

### Output Impedance Error

An additional error source is caused by transformer secondary current flow through the real life nonzero impedances of the output rectifier, transformer secondary and output capacitor. Because the secondary current only flows during the off portion of the duty cycle, the effective output impedance equals the “DC” lumped secondary impedance times the inverse of the off duty cycle. If the output load current remains relatively constant, or, in less critical applications, the error may be judged acceptable and the feedback resistor divider ratio adjusted for nominal expected error. In more demanding applications, output impedance error may be minimized by the use of the load compensation function (see Load Compensation).

### MINIMUM LOAD CONSIDERATIONS

The LT1737 generally provides better low load performance than previous generation switcher/controllers utilizing indirect output voltage sensing techniques. Specifically, it contains circuitry to detect flyback pulse “collapse,” thereby supporting operation well into discontinuous mode. Nevertheless, there still remain constraints to ultimate low load operation. These relate to the minimum switch on time and the minimum enable time. Discontinuous mode operation will be assumed in the following theoretical derivations.

As outlined in the Operation section, the LT1737 utilizes a minimum output switch on time,  $t_{ON}$ . This value can be combined with expected  $V_{IN}$  and switching frequency to yield an expression for minimum delivered power.

$$\begin{aligned} \text{Minimum Power} &= \frac{1}{2} \left( \frac{f}{L_{PRI}} \right) (V_{IN} \cdot t_{ON})^2 \\ &= V_{OUT} \cdot I_{OUT} \end{aligned}$$

This expression then yields a minimum output current constraint:

$$I_{OUT(MIN)} = \frac{1}{2} \left( \frac{f}{L_{PRI} \cdot V_{OUT}} \right) (V_{IN} \cdot t_{ON})^2 \text{ where}$$

$f$  = switching frequency

$L_{PRI}$  = transformer primary side inductance

$V_{IN}$  = input voltage

$V_{OUT}$  = output voltage

$t_{ON}$  = output switch minimum on time

An additional constraint has to do with the minimum enable time. The LT1737 derives its output voltage information from the flyback pulse. If the internal minimum enable time pulse extends beyond the flyback pulse, loss of regulation will occur. The onset of this condition can be determined by setting the width of the flyback pulse equal to the sum of the flyback enable delay,  $t_{ED}$ , plus the minimum enable time,  $t_{EN}$ . Minimum power delivered to the load is then:

$$\begin{aligned} \text{Minimum Power} &= \frac{1}{2} \left( \frac{f}{L_{SEC}} \right) [V_{OUT} \cdot (t_{EN} + t_{ED})]^2 \\ &= V_{OUT} \cdot I_{OUT} \end{aligned}$$

Which yields a minimum output constraint:

$$I_{OUT(MIN)} = \frac{1}{2} \left( \frac{f \cdot V_{OUT}}{L_{SEC}} \right) (t_{ED} + t_{EN})^2 \text{ where}$$

$f$  = switching frequency

$L_{SEC}$  = transformer secondary side inductance

$V_{OUT}$  = output voltage

$t_{ED}$  = enable delay time

$t_{EN}$  = minimum enable time

Note that generally, depending on the particulars of input and output voltages and transformer inductance, one of the above constraints will prove more restrictive. In other words, the minimum load current in a particular application will be either “output switch minimum on time” constrained, or “minimum flyback pulse time” constrained. (A final note— $L_{PRI}$  and  $L_{SEC}$  refer to transformer inductance as seen from the primary or secondary side respectively. This general treatment allows these expressions to be used when the transformer turns ratio is nonunity.)

## APPLICATIONS INFORMATION

### MAXIMUM LOAD/SHORT-CIRCUIT CONSIDERATIONS

The LT1737 is a current mode controller. It uses the  $V_C$  node voltage as an input to a current comparator that turns off the output switch on a cycle-by-cycle basis as this peak current is reached. The internal clamp on the  $V_C$  node, nominally 2.5V, then acts as an output switch peak current limit.

This 2.5V at the  $V_C$  pin corresponds to a value of 250mV at the  $I_{SENSE}$  pin, when the (ON) switch duty cycle is less than 40%. For a duty cycle above 40%, the internal slope compensation mechanism lowers the effective  $I_{SENSE}$  voltage limit. For example, at a duty cycle of 80%, the nominal  $I_{SENSE}$  voltage limit is 220mV. This action becomes the switch current limit specification. Maximum available output power is then determined by the switch current limit, which is somewhat duty cycle dependent due to internal slope compensation action.

Overcurrent conditions are handled by the same mechanism. The output switch turns on, the peak current is quickly reached and the switch is turned off. Because the output switch is only on for a small fraction of the available period, power dissipation is controlled.

Loss of current limit is possible under certain conditions. Remember that the LT1737 normally exhibits a minimum switch on time, irrespective of current trip point. If the duty cycle exhibited by this minimum on time is greater than the ratio of secondary winding voltage (referred-to-primary) divided by input voltage, then peak current will not be controlled at the nominal value, and will cycle-by-cycle ratchet up to some higher level. Expressed mathematically, the requirement to maintain short-circuit control is:

$$t_{ON} \cdot f < \frac{(V_F + I_{SC} \cdot R_{SEC})}{V_{IN} \cdot N_{SP}} \text{ where}$$

$t_{ON}$  = output switch minimum on time

$f$  = switching frequency

$I_{SC}$  = short-circuit output current

$V_F$  = output diode forward voltage at  $I_{SC}$

$R_{SEC}$  = resistance of transformer secondary

$V_{IN}$  = input voltage

$N_{SP}$  = secondary-to-primary turns ratio ( $N_{SEC}/N_{PRI}$ )

Trouble is typically only encountered in applications with a relatively high product of input voltage times secondary-to-primary turns ratio and/or a relatively long minimum switch on time. (Additionally, several real world effects such as transformer leakage inductance, AC winding losses, and output switch voltage drop combine to make this simple theoretical calculation a conservative estimate.)

### THERMAL CONSIDERATIONS

Care should be taken to ensure that the worst-case input voltage condition does not cause excessive die temperatures. The 16-lead SO package is rated at 100°C/W, and the 16-lead GN at 110°C/W.

Average supply current is simply the sum of quiescent current given in the specifications section plus gate drive current. Gate drive current can be computed as:

$$I_G = f \cdot Q_G \text{ where}$$

$Q_G$  = total gate charge

$f$  = switching frequency

(Note: Total gate charge is more complicated than  $C_{GS} \cdot V_G$  as it is frequently dominated by Miller effect of the  $C_{GD}$ . Furthermore, both capacitances are nonlinear in practice. Fortunately, most MOSFET data sheets provide figures and graphs which yield the total gate charge directly per operating conditions.) Nearly all gate drive power is dissipated in the IC, except for a small amount in the external gate series resistor, so total IC dissipation may be computed as:

$$P_{D(TOTAL)} = V_{CC} (I_Q + f \cdot Q_G), \text{ where}$$

$I_Q$  = quiescent current (from specifications)

$Q_G$  = total gate charge

$f$  = switching frequency

$V_{CC}$  = LT1737 supply voltage

### SWITCH NODE CONSIDERATIONS

For maximum efficiency, gate drive rise and fall times are made as short as practical. To prevent radiation and high frequency resonance problems, proper layout of the components connected to the IC is essential, especially

## APPLICATIONS INFORMATION

the power paths (primary *and* secondary). B field (magnetic) radiation is minimized by keeping MOSFET leads, output diode and output bypass capacitor leads as short as possible. E field radiation is kept low by minimizing the length and area of all similar traces. A ground plane should always be used under the switcher circuitry to prevent interplane coupling.

The high speed switching current paths are shown schematically in Figure 7. Minimum lead length in these paths are essential to ensure clean switching and minimal EMI. The path containing the input capacitor, transformer primary and MOSFET, and the path containing the transformer secondary, output diode and output capacitor contain “nanosecond” rise and fall times. Keep these paths as short as possible.

### GATE DRIVE RESISTOR CONSIDERATIONS

The gate drive circuitry internal to the LT1737 has been designed to have as low an output impedance as practically possible—only a few ohms. A strong L/C resonance is potentially presented by the inductance of the path leading to the gate of the power MOSFET and its overall gate capacitance. For this reason the path from the GATE package pin to the physical MOSFET gate should be kept as short as possible, and good layout/ground plane practice used to minimize the parasitic inductance.

An explicit series gate drive resistor may be useful in some applications to damp out this potential L/C resonance (typically tens of MHz). A minimum value of perhaps several ohms is suggested, and higher values (typically a few tens of ohms) will offer increased damping. However, as this resistor value becomes too large, gate voltage rise time will increase to unacceptable levels, and efficiency will suffer due to the sluggish switching action.

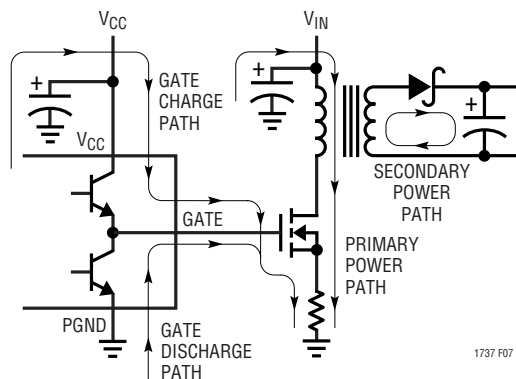

Figure 7. High Speed Current Switching Paths

1737 F07

## TYPICAL APPLICATIONS

### BASIC APPLICATION WITH 3-WINDING TRANSFORMER

Figure 8 shows a compact, low power application of the LT1737. Transformer T1 is an off-the-shelf VERSA-PAC™, #VP1-0190, produced by Coiltronics. As manufactured, it consists of six ideally identical independent windings. In this application, two windings are stacked in series on the primary side and three are placed in parallel on the secondary side. This arrangement provides a 2:1 primary-to-secondary turns ratio while maximizing overall efficiency. The remaining primary side winding provides a ground-referred version of the flyback voltage waveform for the purpose of feedback.

The design accepts an input voltage in the range of 8V to 25V and outputs an isolated 5V. To prevent overvoltage on

the LT1737 and the gate of MOSFET M1, an LT1121 low dropout linear regulator is employed (U2). Resistor divider R11/R12 sets the output of U2 at nominally 8.25V. (A few hundred millivolts of dropout will therefore be seen at the very bottom of the input supply range.) The positive going drive potential at the LT1737 GATE pin is typically 2V or so below its V<sub>CC</sub> supply pin, so a logic level MOSFET has been specified for M1.

Capacitor C6 sets the switching frequency at approximately 200kHz. Optimal load compensation for the transformer and secondary circuit components is set by resistor R8. Resistor R10 provides a guaranteed minimum load of about 20mA to maintain rough output voltage regulation. The soft-start and UVLO features are unused as shown.

VERSA-PAC is a trademark of Coiltronics, Inc.

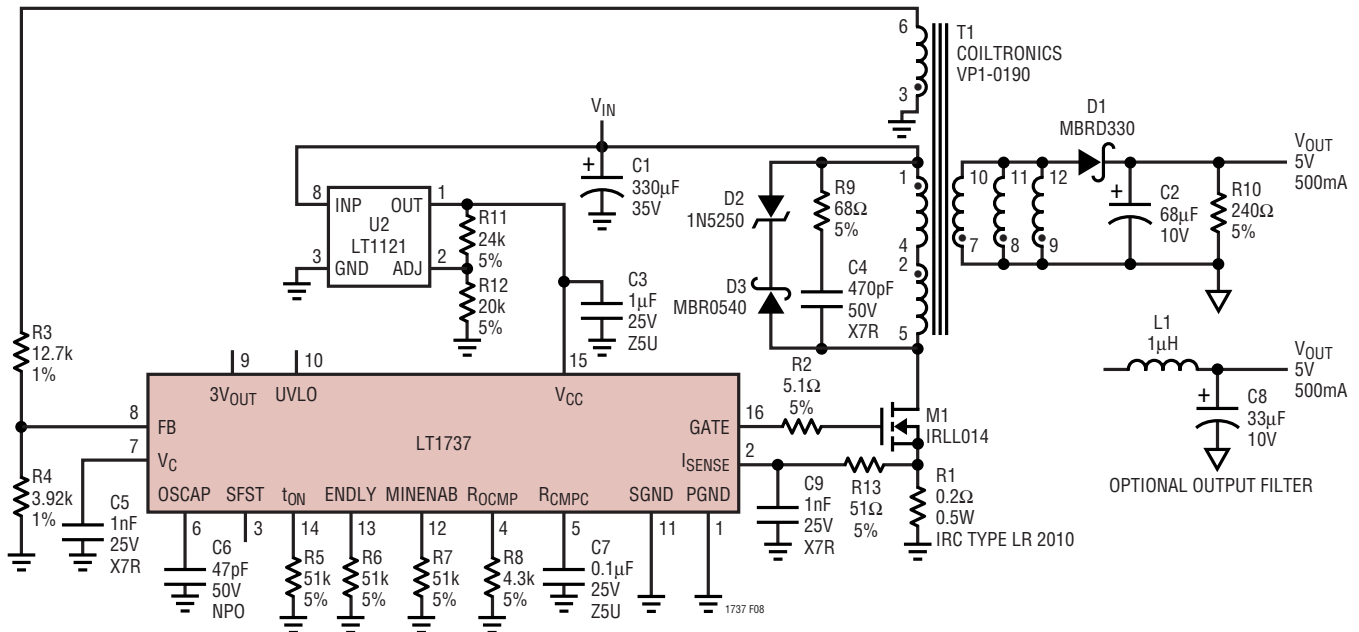

- C1: SANYO ALUMINUM ELECTROLYTIC (35CV331GX)
- C2: SANYO POSCAP (10TPC68M)
- C3: SANYO POSCAP (10TPA33M)
- C4: MOTOROLA 30V, 3A SCHOTTKY RECTIFIER
- C5: 20V, 500mW ZENER DIODE
- C6: MOTOROLA 40V, 0.5A SCHOTTKY RECTIFIER

- L1: COILCRAFT DO1608C-102 1µH, 0.05Ω INDUCTOR
- M1: INT'L RECTIFIER IRLLO14 60V, 0.2Ω LOGIC LEVEL N-CH MOSFET
- U2: LINEAR TECHNOLOGY MICROPOWER LDO REGULATOR

Figure 8. 8V-25V to Isolated 5V Converter

## TYPICAL APPLICATIONS

Overall power supply efficiency and output regulation versus input voltage and load current may be seen in Figures 9 and 10. Available output current is a function of input voltage, varying from 650mA with 8V input to 1100mA with 25V input.

In cases when the output switching noise is objectionable, the optional output L/C filter shown may be added. The oscilloscope photos in Figure 11 show the dramatic reduction in output voltage ripple with the optional filter.

Note: It is theoretically possible to extend the input voltage range of this topology higher by raising the breakdown voltage ratings on Q1, U2 and M1, while adjusting the transformer windings as necessary. However this approach is generally undesirable as the relatively fixed

supply current required by the LT1737 generates more and more wasted heat in linear regulator U2 as input voltage is increased. The LT1725, a close “cousin” of the LT1737 is recommended in such instances.

The LT1725 is very similar to the LT1737, but it contains an integral wide hysteresis undervoltage lockout (UVLO) circuit that monitors the  $V_{CC}$  voltage. When used in conjunction with a 3-winding transformer to provide both device power and output voltage feedback information, this allows for a “trickle charge” start-up from an input voltage of up to hundreds of volts. The LT1725 is thus well suited to operate from “telecom” input voltages of 48V to 72V, or even offline inputs up to several hundred volts! See the LT1725 data sheet for further information.

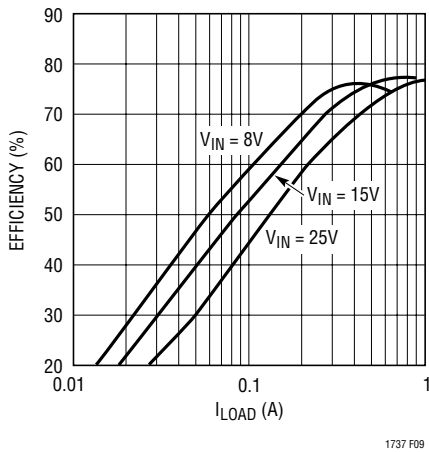

Figure 9. Efficiency vs  $I_{LOAD}$

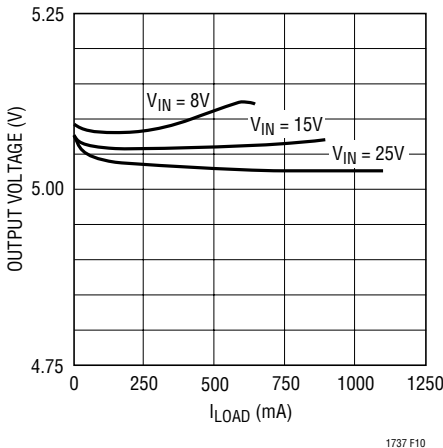

Figure 10. Output Regulation

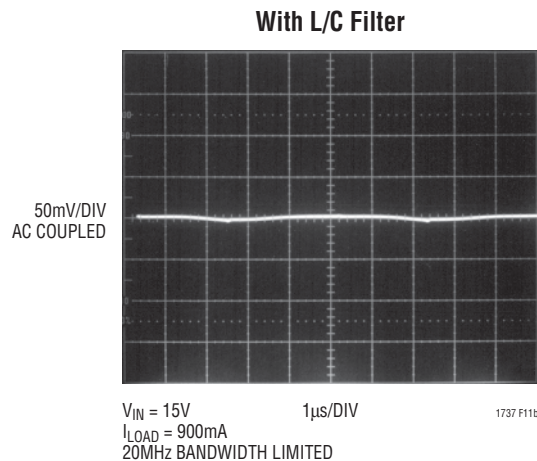
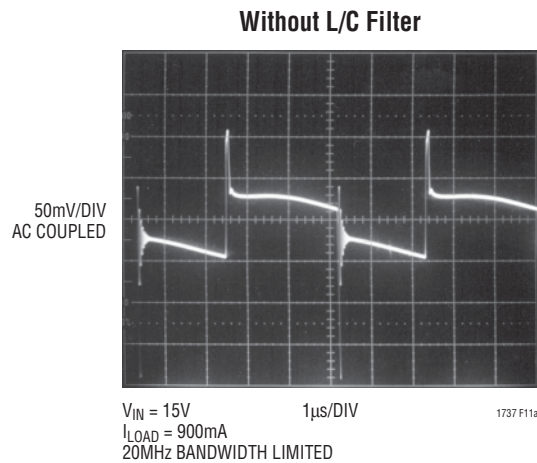

Figure 11

# TYPICAL APPLICATIONS

## APPLICATION WITH 2-WINDING TRANSFORMER

The previous application example utilized a 3-winding transformer, the third winding providing only feedback information. Additional circuitry may be employed to provide feedback information, thus allowing the transformer to be reduced to a 2-winding topology. (The cost and size savings associated with the transformer often

make this a preferable alternative. Furthermore, a variety of manufacturers offer off-the-shelf dual wound magnetics which often can be applied as 1:1 transformers.)

Figure 12 shows an LT1737 configured for operation with a dual wound toroid, the Coiltronics #CTX150-4 OCTA-PAC™. A ground referred version of the flyback voltage waveform is now provided by components Q1, R2,

OCTA-PAC is a trademark of Coiltronics, Inc.

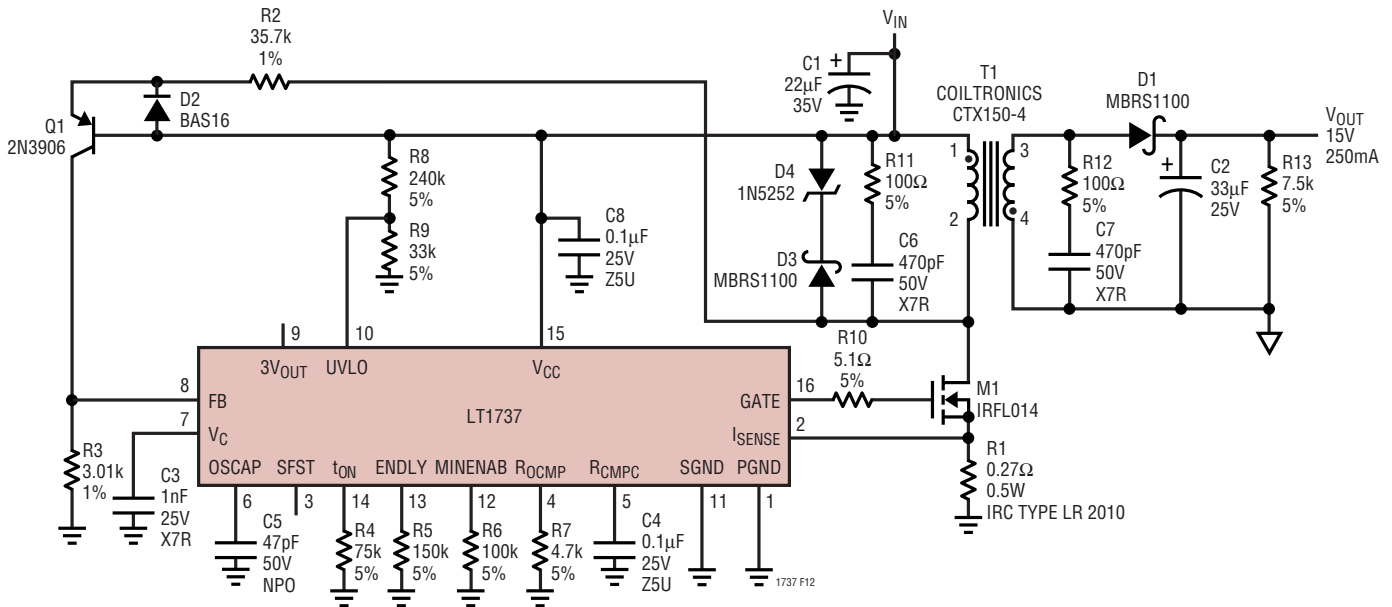

- C1: AVX TPS TANTALUM (TPSE226M035R0300)
- C2: AVX TPS TANTALUM (TPSE336M025R0200)
- D1, D3: MOTOROLA 100V, 1A SCHOTTKY DIODE
- D2: SIGNAL DIODE
- D4: 24V, 500mW ZENER DIODE
- M1: INT'L RECTIFIER 60V, 0.2Ω N-CH MOSFET

Figure 12. 12V-18V to Isolated 15V Converter

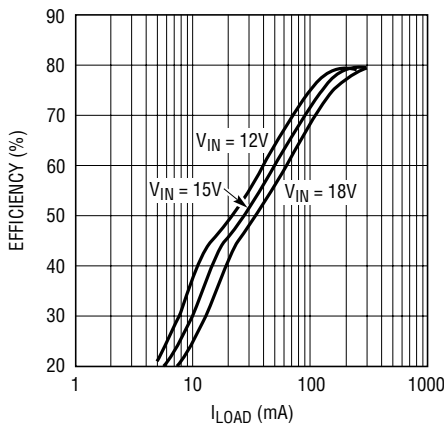

Figure 13. Efficiency vs I\_LOAD

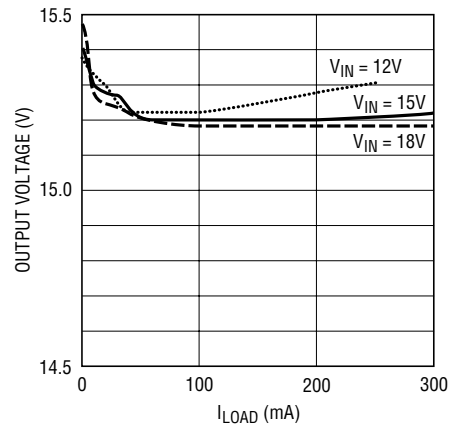

Figure 14. Load Regulation

## TYPICAL APPLICATIONS

R3 and D2. (Diode D2 prevents reverse emitter/base breakdown in Q1 when MOSFET M1 is in the “ON” state.) The raw flyback voltage at the drain of MOSFET M1 minus the  $V_{BE}$  of Q1 is converted to a current by R2 and then back to a voltage at R3. Or, stated mathematically:

$$V_{FB} = (V_{FLBK} - V_{BE}) \left( \frac{R3}{R2} \right)$$

Resistor R13 provides an initial pre-load to the supply output to improve light load regulation. Resistor divider R8/R9 sets the undervoltage lockout threshold at nominally 10.4V for turn-on, with turn-off about 600mV lower. Overall power supply efficiency and output regulation versus input voltage and load current may be seen in Figures 13 and 14.

### 5V<sub>IN</sub> APPLICATION

The LT1737 is a bipolar technology IC specified to operate down to a minimum input supply voltage of 4.5V. Although its GATE pin drives “low” nearly to ground, its “high” capability is limited by a headroom requirement of roughly  $2V_{BE}$ . Thus when operating at a worst case 4.5V supply, the GATE output will only drive up to a nominal 3V or so. Fortunately, MOSFETs are now available with specified performance at this level of gate voltage.

The circuit shown in Figure 15 provides an isolated 5V output from an input between 4.5V and 5.5V. Two Si9804 low gate voltage MOSFETs are paralleled to handle the primary-side current—up to 12A peak. This circuit provides more output power than the previous examples. It

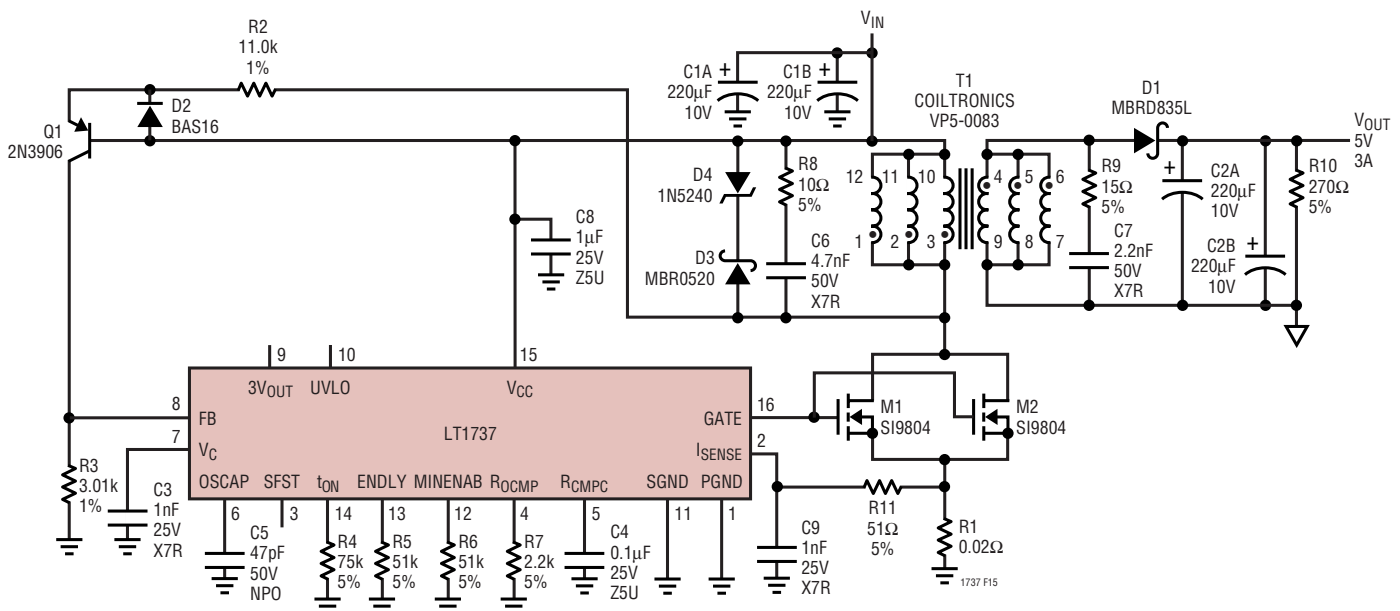

- C1A-B, C2A-B: SANYO POSCAP (10TPB220M)
- D1: MOTOROLA 35V, 8A SCHOTTKY DIODE
- D2: SIGNAL DIODE
- D3: MOTOROLA 20V, 0.5A SCHOTTKY DIODE
- D4: 10V, 500mW ZENER DIODE
- M1, M2: SILICONIX/VISHAY 25V, 0.023Ω N-CH MOSFET
- R1:  $5 \times 0.10\Omega$ , 1W (IRC LR2512)
- T1: COILTRONICS TRANSFORMER

Figure 15. 4.5V-5.5V to Isolated 5V Converter

## TYPICAL APPLICATIONS

therefore requires a physically larger transformer. The largest size VERSA-PAC is used, a VP5-0083. Three windings are paralleled for both the primary and secondary.

Overall power supply efficiency and output regulation versus load current at the nominal  $V_{IN} = 5V$  may be seen in Figures 16 and 17.

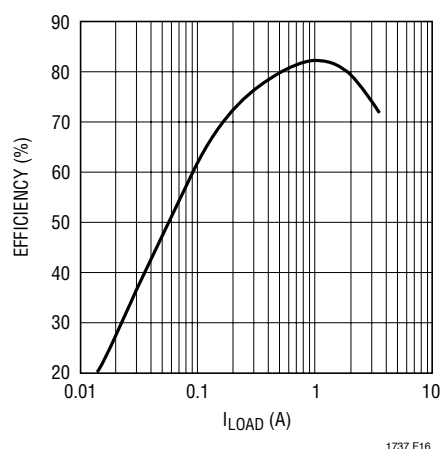

Figure 16. Efficiency vs  $I_{LOAD}$

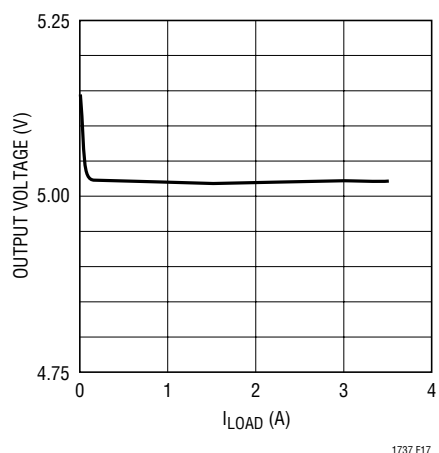

Figure 17. Load Regulation

## NONISOLATED APPLICATION

While the LT1737 was designed to serve isolated flyback applications, it is useful to note that it is also capable of supporting nonisolated applications. These are performed by providing a continuous pseudo-DC feedback signal to the FB pin. (The part behaves as if the flyback waveform is infinitely long.) Figure 18 demonstrates just such a system.

A SEPIC topology is shown whereby a 8V to 16V input is converted to a nonisolated 12V output. A conventional resistive feedback divider, R3/R4 drives the FB pin. (Capacitor C7 serves to filter out high frequency ripple in the output voltage.) A combination of an R/C network (R11/C5) in parallel with a single capacitor (C9) on the  $V_C$  node provides the required loop compensation. The load compensation function is unwanted, so the  $R_{OCMP}$  pin is left open and the  $R_{CMPC}$  pin is grounded. An LT1121 low dropout regulator is programmed to a nominal 8.25V output by the R12/R13 resistor divider, and this allows the LT1737 to drive M1, a logic level MOSFET. Minimum on time programming resistor R5 is set to 33k to minimize the required output preload. Minimum enable time has no direct effect on steady state operation, but programming resistor R7 has been set to 100k for rapid start-up. Enable delay resistor is similarly set to 24k.

Overall power supply efficiency versus input voltage and load current may be seen in Figure 19. Because this application example utilizes a nonisolated topology, load regulation is not an issue. It is typically 0.2% (25mV) from no load to full load.

Other nonisolated switching topologies may be similarly implemented. For example, Boost and Nonisolated Flyback readily suggest themselves. (A Nonisolated Flyback topology also can be used to generate a *negative* output voltage. In this case, the feedback is a dynamic waveform derived from the primary side of the transformer, similar to an isolated LT1737 application.)

**PACKAGE DESCRIPTION**

Dimensions in inches (millimeters) unless otherwise noted.

**GN Package  
16-Lead Plastic SSOP (Narrow 0.150)**  
(LTC DWG # 05-08-1641)

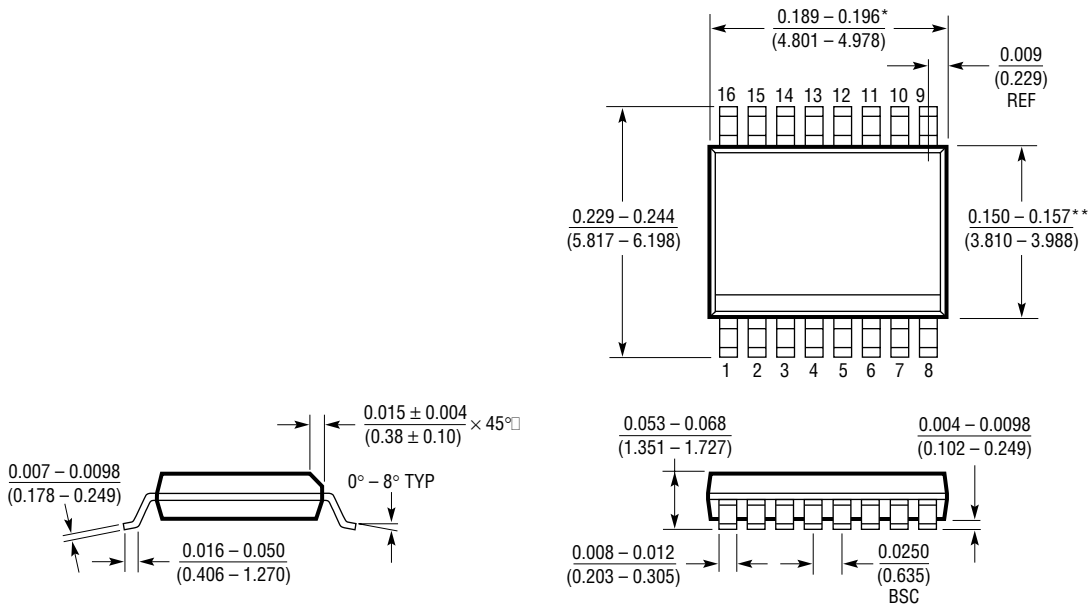

\* DIMENSION DOES NOT INCLUDE MOLD FLASH. MOLD FLASH SHALL NOT EXCEED 0.006" (0.152mm) PER SIDE  
 \*\* DIMENSION DOES NOT INCLUDE INTERLEAD FLASH. INTERLEAD FLASH SHALL NOT EXCEED 0.010" (0.254mm) PER SIDE

GN16 (SSOP) 1098

**PACKAGE DESCRIPTION** Dimensions in inches (millimeters) unless otherwise noted.

**S Package**  
**16-Lead Plastic Small Outline (Narrow 0.150)**  
 (LTC DWG # 05-08-1610)

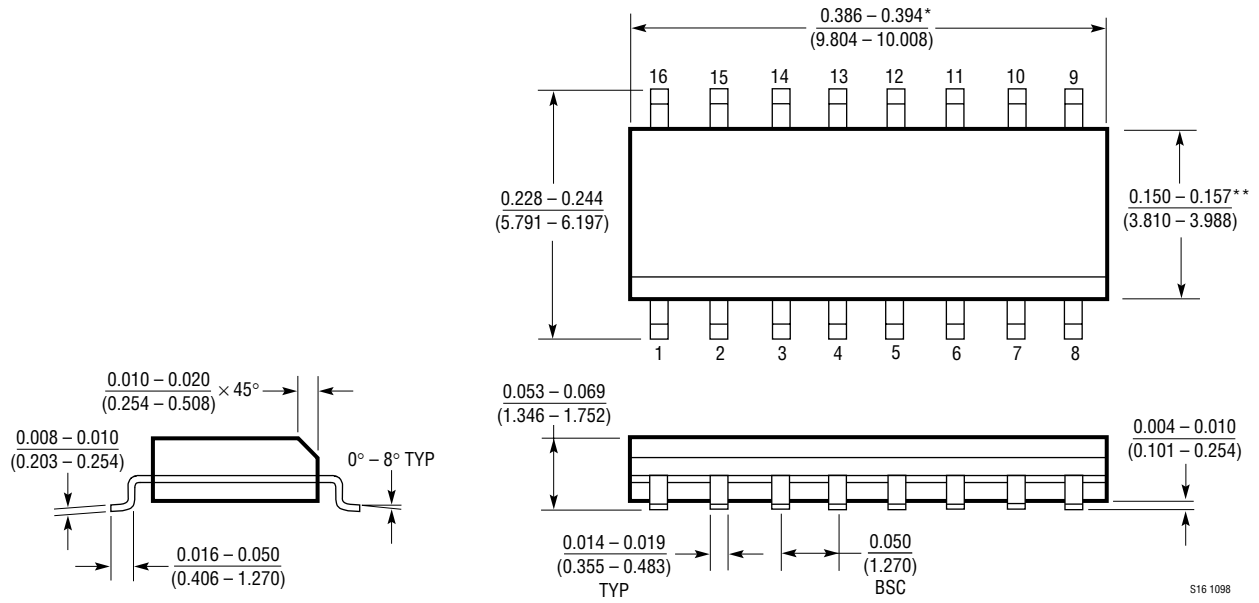

\* DIMENSION DOES NOT INCLUDE MOLD FLASH. MOLD FLASH SHALL NOT EXCEED 0.006" (0.152mm) PER SIDE  
 \*\* DIMENSION DOES NOT INCLUDE INTERLEAD FLASH. INTERLEAD FLASH SHALL NOT EXCEED 0.010" (0.254mm) PER SIDE

S16 1098

TYPICAL APPLICATIONS

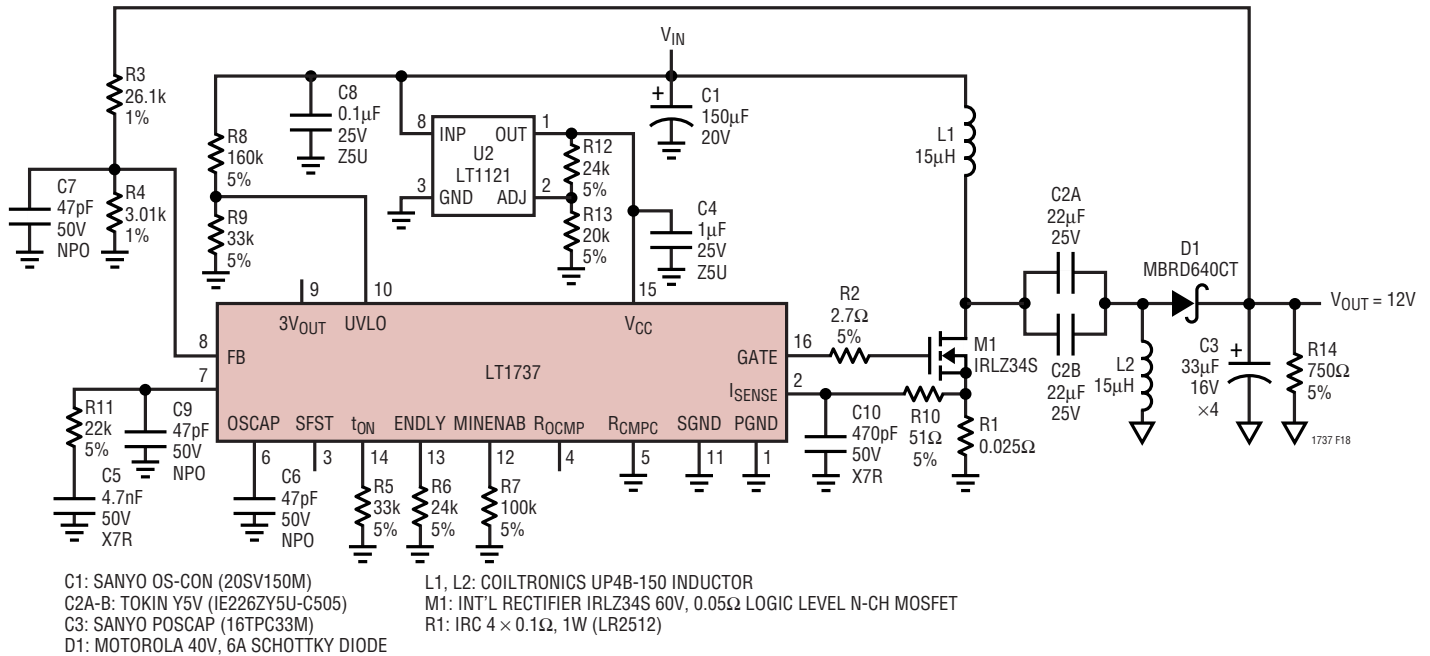

Figure 18. 8V-16V to 12V Nonisolated Converter

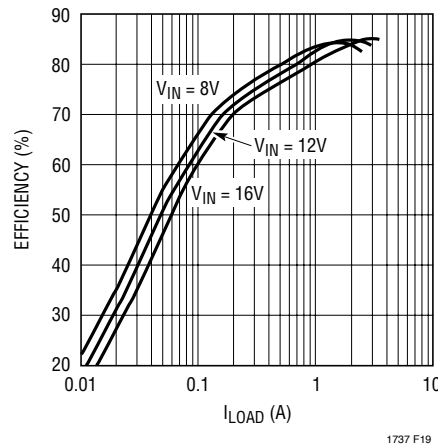

Figure 19. Efficiency vs I\_LOAD

RELATED PARTS

PART NUMBER	DESCRIPTION	COMMENTS
LT1424-5	Isolated Flyback Switching Regulator	V <sub>IN</sub> = 3V to 20V, I <sub>Q</sub> = 7mA
LT1424-9	Isolated Flyback Switching Regulator	V <sub>IN</sub> = 3V to 20V, I <sub>Q</sub> = 7mA
LT1425	Isolated Flyback Switching Regulator	General Purpose with External Application Resistor
LT1533	Ultralow Noise 1A Switching Regulator	V <sub>IN</sub> = 2.7V to 23V, Reduced EMI and Switching Harmonics
LT1725	General Purpose Isolated Flyback Controller	Suitable for Telecom or Offline Input Voltage
LT1738	Ultra Low Noise DC/DC Controller	Reduced EMI and Switching Harmonics

## Looking for pricing, stock, or lifecycle information?

Click below to explore more details on WIN SOURCE:

 [View LT1737CS#TR on WIN SOURCE](#)

 [Linear Technology](#) Information

## Optimize Your Supply Chain with WIN SOURCE Solutions

-  Global Sourcing Solution
-  Obsolete Management
-  Cost Control Management
-  Shortage Management
-  Alternative Solution
-  Excess Inventory Management