



**THE DATASHEET OF
LT1936EMS8E#PBF**



FEATURES

- Wide Input Range: 3.6V to 36V
- Short-Circuit Protected Over Full Input Range
- 1.9A Guaranteed Minimum Switch Current
- 5V at 1.4A from 10V to 36V Input
- 3.3V at 1.4A from 7V to 36V Input
- 5V at 1.2A from 6.3V to 36V Input
- 3.3V at 1.2A from 4.5V to 36V Input
- Output Adjustable Down to 1.20V
- 500kHz Fixed Frequency Operation
- Soft-Start
- Uses Small Ceramic Capacitors
- Internal or External Compensation
- Low Shutdown Current: <math><2\mu\text{A}</math>
- Thermally Enhanced 8-Lead MSOP Package

APPLICATIONS

- Automotive Battery Regulation
- Industrial Control Supplies
- Unregulated Wall Adapters

DESCRIPTION

The LT[®]1936 is a current mode PWM step-down DC/DC converter with an internal 1.9A power switch, packaged in a tiny, thermally enhanced 8-lead MSOP. The wide input range of 3.6V to 36V makes the LT1936 suitable for regulating power from a wide variety of sources, including automotive batteries, 24V industrial supplies and unregulated wall adapters. Its high operating frequency allows the use of small, low cost inductors and ceramic capacitors, resulting in low, predictable output ripple.

Cycle-by-cycle current limit, frequency foldback and thermal shutdown provide protection against shorted outputs, and soft-start eliminates input current surge during start-up. Transient response can be optimized by using external compensation components, or board space can be minimized by using internal compensation. The low current (<math><2\mu\text{A}</math>) shutdown mode enables easy power management in battery-powered systems.

LT, LT, LTC and LTM are registered trademarks of Linear Technology Corporation. All other trademarks are the property of their respective owners.

TYPICAL APPLICATION

3.3V Step-Down Converter

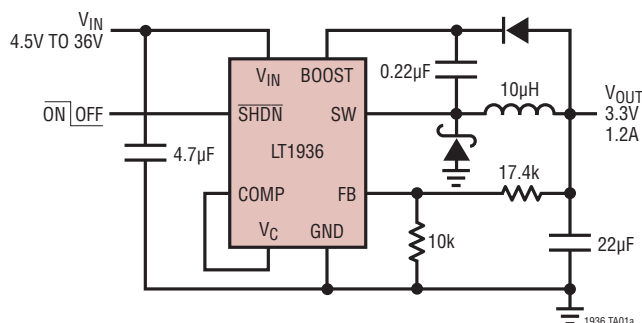

Efficiency

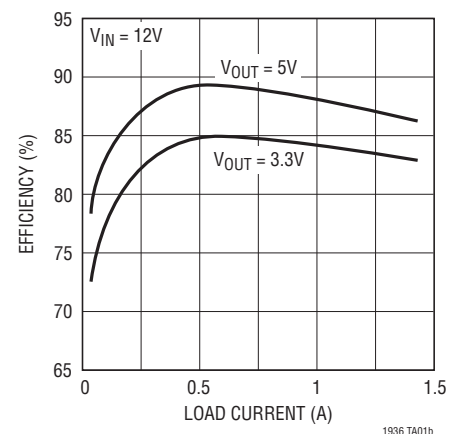

ABSOLUTE MAXIMUM RATINGS

(Note 1)

V_{IN} Voltage	-0.4V to 36V
BOOST Voltage	43V
BOOST Above SW Voltage	20V
SHDN Voltage	-0.4V to 36V
FB, V_C , COMP Voltage	6V
Operating Temperature Range (Note 2)	
LT1936E	-40°C to 85°C
LT1936I	-40°C to 125°C
LT1936H	-40°C to 150°C
Maximum Junction Temperature	
LT1936E, LT1936I	125°C
LT1936H	150°C
Storage Temperature Range	-65°C to 150°C
Lead Temperature (Soldering, 10 sec)	300°C

PIN CONFIGURATION

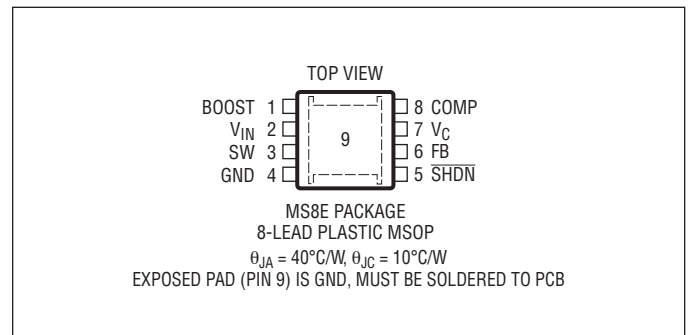

ORDER INFORMATION

LEAD FREE FINISH	TAPE AND REEL	PART MARKING	PACKAGE DESCRIPTION	TEMPERATURE RANGE
LT1936EMS8E#PBF	LT1936EMS8E#TRPBF	LTBMT	8-Lead Plastic MSOP	-40°C to 85°C
LT1936IMS8E#PBF	LT1936IMS8E#TRPBF	LTBRV	8-Lead Plastic MSOP	-40°C to 125°C
LT1936HMS8E#PBF	LT1936HMS8E#TRPBF	LTBWB	8-Lead Plastic MSOP	-40°C to 150°C
LEAD BASED FINISH	TAPE AND REEL	PART MARKING	PACKAGE DESCRIPTION	TEMPERATURE RANGE
LT1936EMS8E	LT1936EMS8E#TR	LTBMT	8-Lead Plastic MSOP	-40°C to 85°C
LT1936IMS8E	LT1936IMS8E#TR	LTBRV	8-Lead Plastic MSOP	-40°C to 125°C
LT1936HMS8E	LT1936HMS8E#TR	LTBWB	8-Lead Plastic MSOP	-40°C to 150°C

Consult LTC Marketing for parts specified with wider operating temperature ranges.

For more information on lead free part marking, go to: <http://www.linear.com/leadfree/>

For more information on tape and reel specifications, go to: <http://www.linear.com/tapeandreel/>

ELECTRICAL CHARACTERISTICS

The ● denotes the specifications which apply over the full operating temperature range, otherwise specifications are at $T_A = 25^\circ\text{C}$. $V_{IN} = 12\text{V}$, $V_{BOOST} = 17\text{V}$, unless otherwise noted. (Note 2)

PARAMETER	CONDITIONS	MIN	TYP	MAX	UNITS
Undervoltage Lockout			3.45	3.6	V
Quiescent Current	$V_{FB} = 1.5\text{V}$		1.8	2.5	mA
Quiescent Current in Shutdown	$V_{SHDN} = 0\text{V}$		0.1	2	μA
FB Voltage		● 1.175	1.200	1.215	V
FB Pin Bias Current (Note 4)	$V_{FB} = 1.20\text{V}$, E and I Grades	●	50	200	nA
	H Grade	●	50	300	nA
FB Voltage Line Regulation	$V_{IN} = 5\text{V to } 36\text{V}$		0.01		%/V
Error Amp gm	$V_C = 0.5\text{V}$, $I_{VC} = \pm 5\mu\text{A}$		250		μS
Error Amp Voltage Gain	$V_C = 0.8\text{V}, 1.2\text{V}$		150		

ELECTRICAL CHARACTERISTICS The ● denotes the specifications which apply over the full operating temperature range, otherwise specifications are at $T_A = 25^\circ\text{C}$. $V_{IN} = 12\text{V}$, $V_{BOOST} = 17\text{V}$, unless otherwise noted. (Note 2)

V_C Clamp			1.8		V	
V_C Switch Threshold			0.7		V	
Internal Compensation R			50		$\text{k}\Omega$	
Internal Compensation C	$V_{COMP} = 1\text{V}$		150		μF	
COMP Pin Leakage	$V_{COMP} = 1.8\text{V}$, E and I Grades H Grade	● ●		1 2	μA μA	
Switching Frequency	$V_{FB} = 1.1\text{V}$ $V_{FB} = 0\text{V}$		400 500 600	500 40	kHz kHz	
Maximum Duty Cycle		●	87	92	%	
Switch Current Limit	(Note 3)		1.9	2.2	2.6	A
Switch V_{CESAT}	$I_{SW} = 1.2\text{A}$			410	520	mV
Switch Leakage Current				2	μA	
Minimum BOOST Voltage Above SW	$I_{SW} = 1.2\text{A}$			2	2.2	V
BOOST Pin Current	$I_{SW} = 1.2\text{A}$			28	50	mA
BOOST Pin Leakage	$V_{SW} = 0\text{V}$			0.1	1	μA
$\overline{\text{SHDN}}$ Input Voltage High			2.3		V	
$\overline{\text{SHDN}}$ Input Voltage Low				0.3	V	
$\overline{\text{SHDN}}$ Pin Current	$V_{\overline{\text{SHDN}}} = 2.3\text{V}$ (Note 5) $V_{\overline{\text{SHDN}}} = 12\text{V}$ (Note 5) $V_{\overline{\text{SHDN}}} = 0\text{V}$			34 140 0.01	50 240 0.1	μA μA μA

Note 1: Stresses beyond those listed under Absolute Maximum Ratings may cause permanent damage to the device. Exposure to any Absolute Maximum Rating condition for extended periods may affect device reliability and lifetime.

Note 2: The LT1936E is guaranteed to meet performance specifications from 0°C to 70°C . Specifications over the -40°C to 85°C operating temperature range are assured by design, characterization and correlation

with statistical process controls. The LT1936I specifications are guaranteed over the -40°C to 125°C temperature range. The LT1936H specifications are guaranteed over the -40°C to 150°C temperature range.

Note 3: Current limit guaranteed by design and/or correlation to static test. Slope compensation reduces current limit at higher duty cycle.

Note 4: Current flows out of pin.

Note 5: Current flows into pin.

TYPICAL PERFORMANCE CHARACTERISTICS

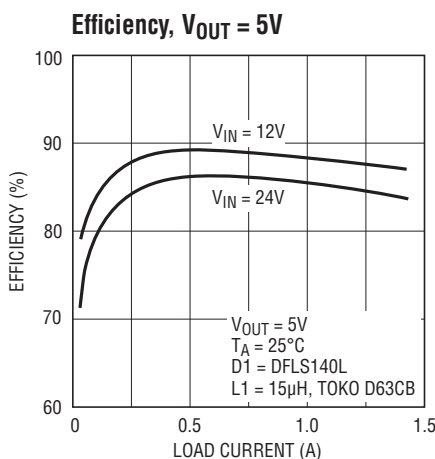

1936 G01

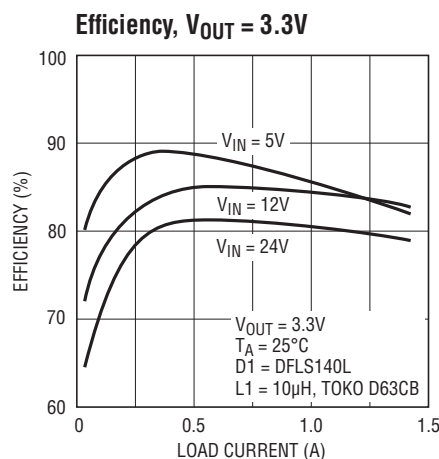

1936 G02

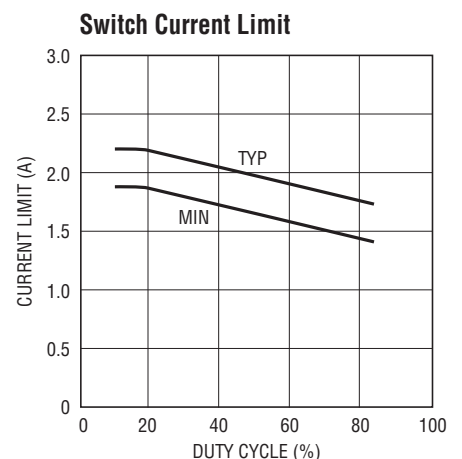

1936 G03

TYPICAL PERFORMANCE CHARACTERISTICS

Maximum Load Current

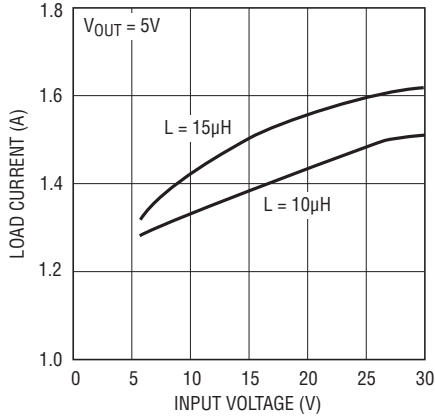

1936 G04

Maximum Load Current

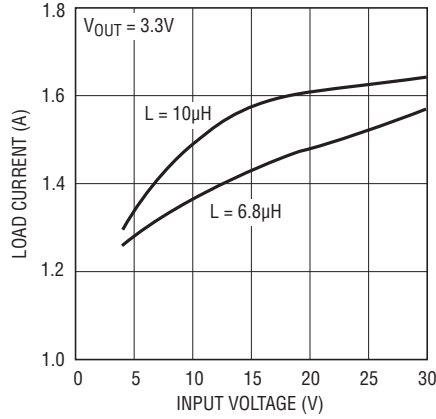

1936 G05

Switch Voltage Drop

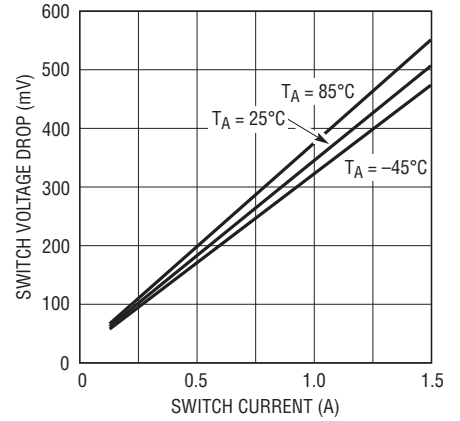

1936 G06

Feedback Voltage

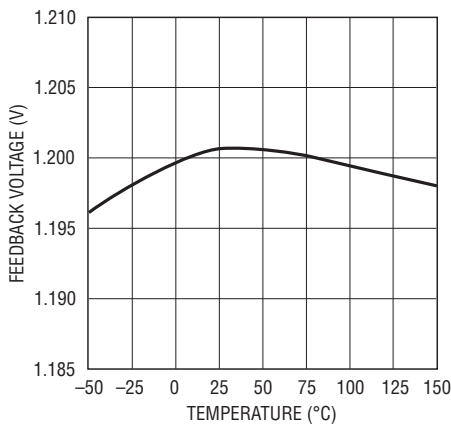

1936 G07

Undervoltage Lockout

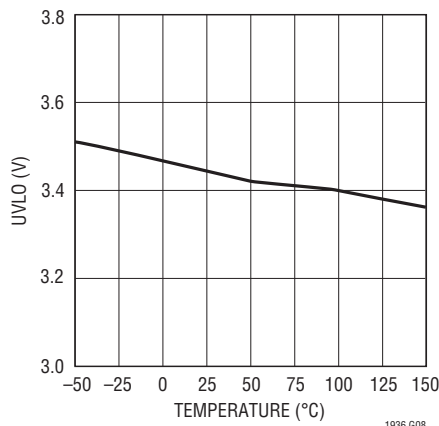

1936 G08

Switching Frequency

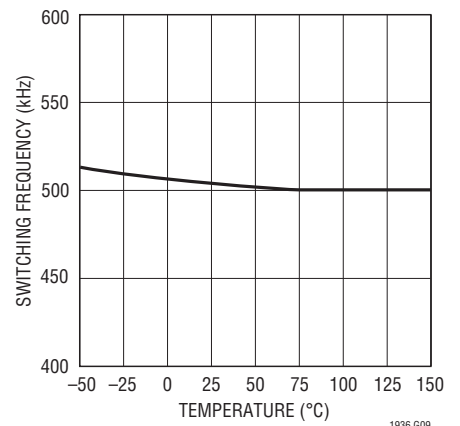

1936 G09

Frequency Foldback

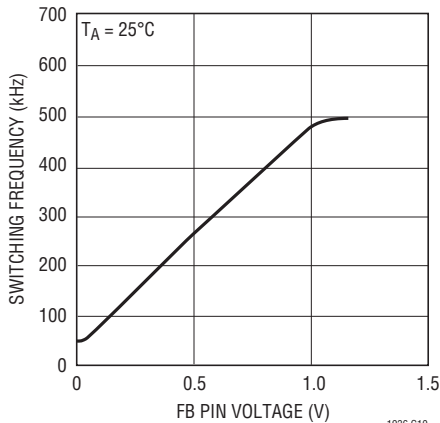

1936 G10

Soft-Start

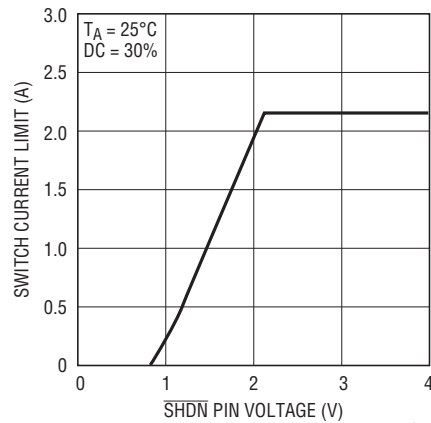

1936 G11

SHDN Pin Current

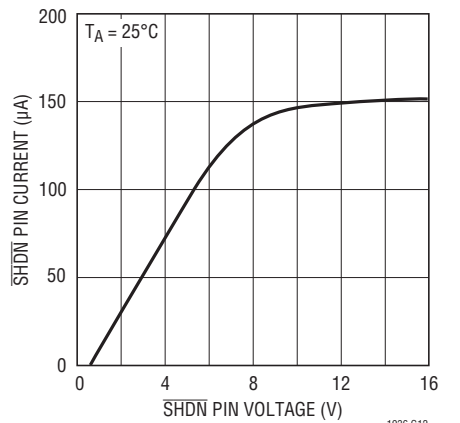

1936 G12

TYPICAL PERFORMANCE CHARACTERISTICS

Minimum Input Voltage

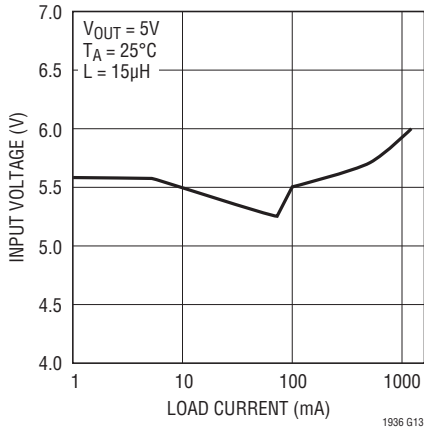

Minimum Input Voltage

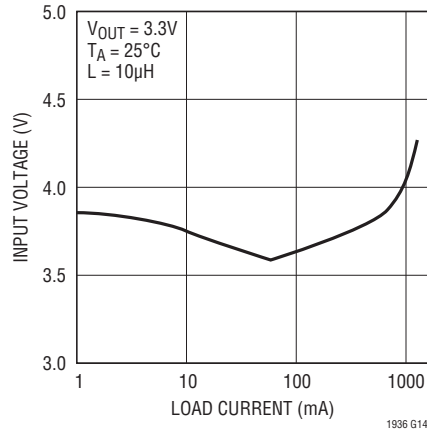

Switch Current Limit

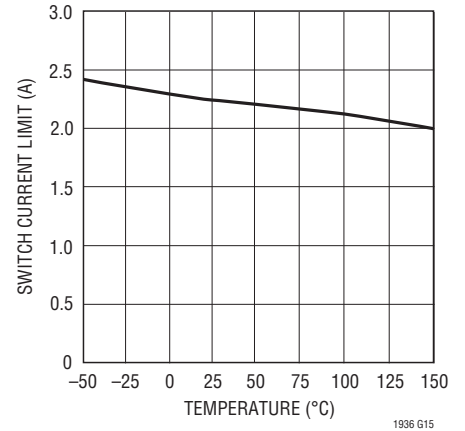

Switching Waveforms

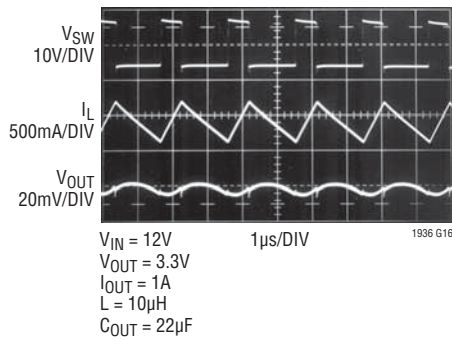

Switching Waveforms, Discontinuous Mode

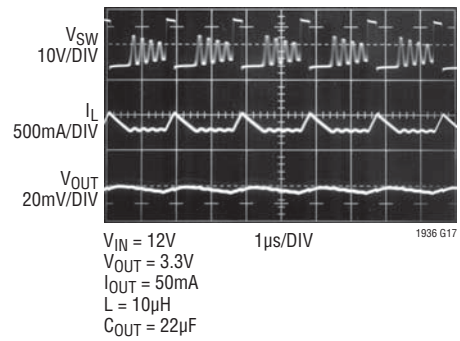

V_C Voltages

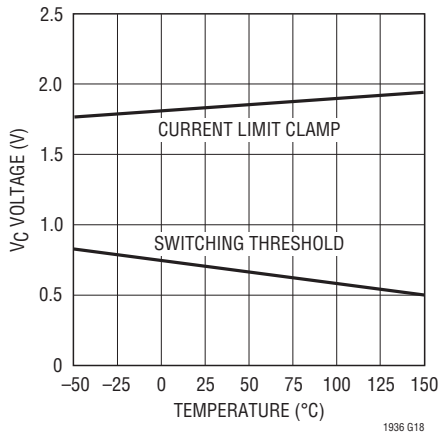

Error Amp Output Current

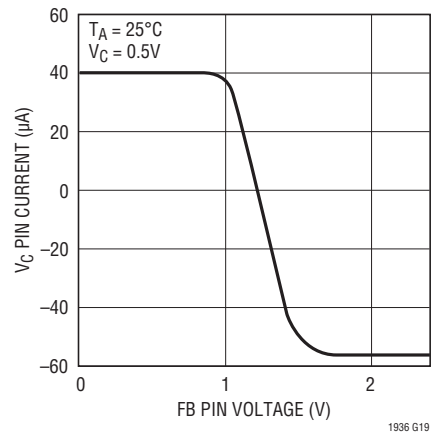

PIN FUNCTIONS

BOOST (Pin 1): The BOOST pin is used to provide a drive voltage, higher than the input voltage, to the internal bipolar NPN power switch.

V_{IN} (Pin 2): The V_{IN} pin supplies current to the LT1936's internal regulator and to the internal power switch. This pin must be locally bypassed.

SW (Pin 3): The SW pin is the output of the internal power switch. Connect this pin to the inductor, catch diode and boost capacitor.

GND (Pin 4): Tie the GND pin to a local ground plane below the LT1936 and the circuit components. Return the feedback divider to this pin.

SHDN (Pin 5): The SHDN pin is used to put the LT1936 in shutdown mode. Tie to ground to shut down the LT1936. Tie to 2.3V or more for normal operation. If the shutdown feature is not used, tie this pin to the V_{IN} pin. SHDN also provides a soft-start function; see the Applications Information. Do not drive SHDN more than 5V above V_{IN}.

FB (Pin 6): The LT1936 regulates its feedback pin to 1.200V. Connect the feedback resistor divider tap to this pin. Set the output voltage according to $V_{OUT} = 1.200V (1 + R1/R2)$. A good value for R2 is 10k.

V_C (Pin 7): The V_C pin is used to compensate the LT1936 control loop by tying an external RC network from this pin to ground. The COMP pin provides access to an internal RC network that can be used instead of the external components.

COMP (Pin 8): To use the internal compensation network, tie the COMP pin to the V_C pin. Otherwise, tie COMP to ground or leave it floating.

Exposed Pad (Pin 9): The Exposed Pad must be soldered to the PCB and electrically connected to ground. Use a large ground plane and thermal vias to optimize thermal performance.

BLOCK DIAGRAM

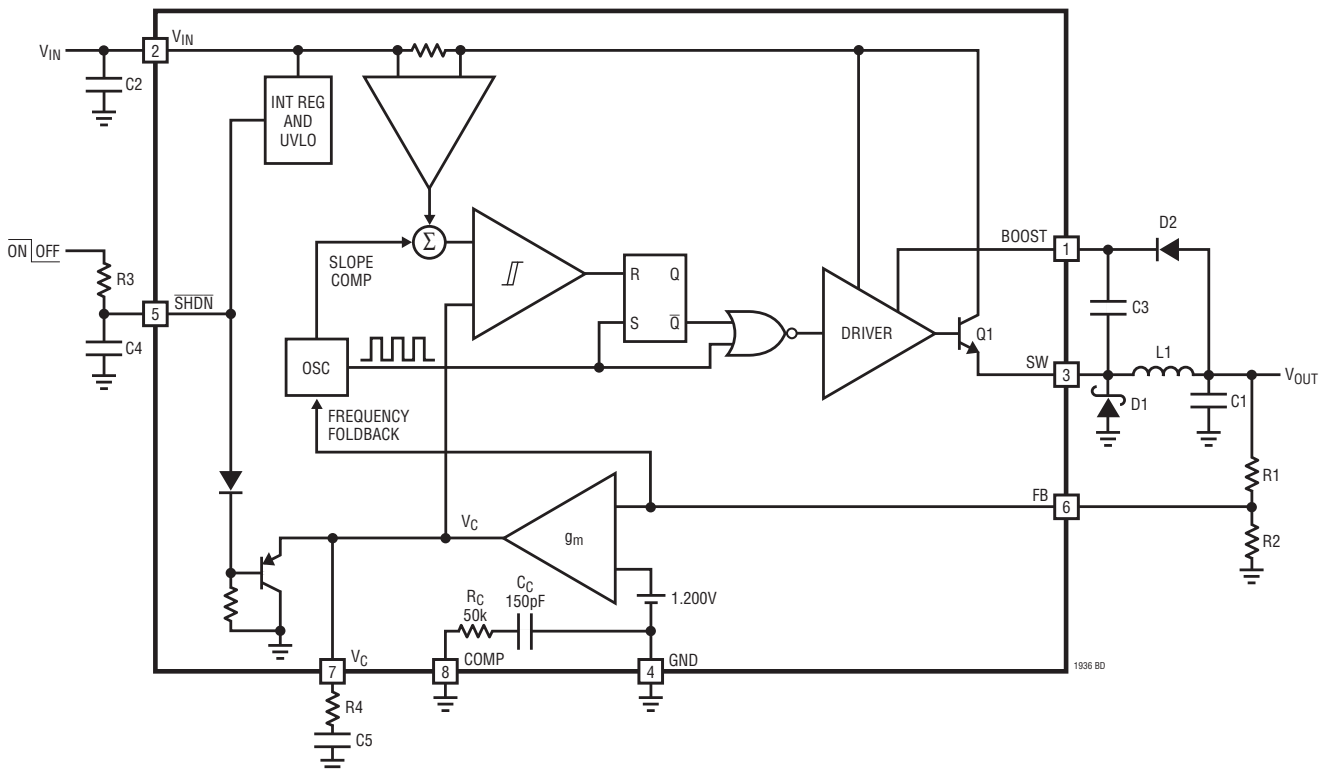

OPERATION (Refer to Block Diagram)

The LT1936 is a constant frequency, current mode step-down regulator. A 500kHz oscillator enables an RS flip-flop, turning on the internal 1.9A power switch Q1. An amplifier and comparator monitor the current flowing between the V_{IN} and SW pins, turning the switch off when this current reaches a level determined by the voltage at V_C . An error amplifier measures the output voltage through an external resistor divider tied to the FB pin and servos the V_C pin. If the error amplifier's output increases, more current is delivered to the output; if it decreases, less current is delivered. An active clamp (not shown) on the V_C pin provides current limit. The V_C pin is also clamped to the voltage on the SHDN pin; soft-start is implemented by generating a voltage ramp at the SHDN pin using an external resistor and capacitor.

An internal regulator provides power to the control circuitry. This regulator includes an undervoltage lockout to prevent switching when V_{IN} is less than $\sim 3.45V$. The SHDN pin is used to place the LT1936 in shutdown, disconnecting the output and reducing the input current to less than $2\mu A$.

The switch driver operates from either the input or from the BOOST pin. An external capacitor and diode are used to generate a voltage at the BOOST pin that is higher than the input supply. This allows the driver to fully saturate the internal bipolar NPN power switch for efficient operation.

The oscillator reduces the LT1936's operating frequency when the voltage at the FB pin is low. This frequency foldback helps to control the output current during startup and overload.

APPLICATIONS INFORMATION

FB Resistor Network

The output voltage is programmed with a resistor divider between the output and the FB pin. Choose the 1% resistors according to:

$$R1 = R2 \left(\frac{V_{OUT}}{1.200} - 1 \right)$$

R2 should be 20k or less to avoid bias current errors. Reference designators refer to the Block Diagram.

Input Voltage Range

The input voltage range for LT1936 applications depends on the output voltage and the Absolute Maximum Ratings of the V_{IN} and BOOST pins.

The minimum input voltage is determined by either the LT1936's minimum operating voltage of ~3.45V or by its maximum duty cycle. The duty cycle is the fraction of time that the internal switch is on and is determined by the input and output voltages:

$$DC = \frac{V_{OUT} + V_D}{V_{IN} - V_{SW} + V_D}$$

where V_D is the forward voltage drop of the catch diode (~0.5V) and V_{SW} is the voltage drop of the internal switch (~0.5V at maximum load). This leads to a minimum input voltage of:

$$V_{IN(MIN)} = \frac{V_{OUT} + V_D}{DC_{MAX}} - V_D + V_{SW}$$

with $DC_{MAX} = 0.87$.

The maximum input voltage is determined by the absolute maximum ratings of the V_{IN} and BOOST pins and by the minimum duty cycle $DC_{MIN} = 0.08$:

$$V_{IN(MAX)} = \frac{V_{OUT} + V_D}{DC_{MIN}} - V_D + V_{SW}$$

Note that this is a restriction on the operating input voltage; the circuit will tolerate transient inputs up to the absolute maximum ratings of the V_{IN} and BOOST pins.

Inductor Selection and Maximum Output Current

A good first choice for the inductor value is

$$L = 2.2 (V_{OUT} + V_D)$$

where V_D is the voltage drop of the catch diode (~0.4V) and L is in μ H. With this value the maximum output current will be above 1.2A at all duty cycles and greater than 1.4A for duty cycles less than 50% ($V_{IN} > 2 V_{OUT}$). The inductor's RMS current rating must be greater than the maximum load current and its saturation current should be about 30% higher. For robust operation in fault conditions (start-up or short circuit) and high input voltage (>30V), the saturation current should be above 2.6A. To keep the efficiency high, the series resistance (DCR) should be less than 0.1Ω , and the core material should be intended for high frequency applications. Table 1 lists several vendors and suitable types.

Table 1. Inductor Vendors

VENDOR	URL	PART SERIES	TYPE
Murata	www.murata.com	LQH55D	Open
TDK	www.component.tdk.com	SLF7045 SLF10145	Shielded Shielded
Toko	www.toko.com	D62CB D63CB D75C D75F	Shielded Shielded Shielded Open
Sumida	www.sumida.com	CR54 CDRH74 CDRH6D38 CR75	Open Shielded Shielded Open

Of course, such a simple design guide will not always result in the optimum inductor for your application. A larger value provides a slightly higher maximum load current and will reduce the output voltage ripple. If your load is lower than 1.2A, then you can decrease the value of the inductor and operate with higher ripple current. This allows you to use a physically smaller inductor, or one with a lower DCR resulting in higher efficiency. Be aware that if the inductance differs from the simple rule above, then the maximum load current will depend on input voltage. There are several graphs in the Typical Performance Characteristics section of this data sheet that show the maximum load current as a function of input voltage and inductor value for several popular output voltages. Low

APPLICATIONS INFORMATION

inductance may result in discontinuous mode operation, which is okay but further reduces maximum load current. For details of maximum output current and discontinuous mode operation, see Linear Technology Application Note 44. Finally, for duty cycles greater than 50% ($V_{OUT}/V_{IN} > 0.5$), there is a minimum inductance required to avoid subharmonic oscillations. Choosing L greater than $1.6(V_{OUT} + V_D) \mu\text{H}$ prevents subharmonic oscillations at all duty cycles.

Catch Diode

A 1A Schottky diode is recommended for the catch diode, D1. The diode must have a reverse voltage rating equal to or greater than the maximum input voltage. The ON Semiconductor MBRM140 is a good choice. It is rated for 1A DC at a case temperature of 110°C and 1.5A at a case temperature of 95°C. Diode Incorporated's DFSL140L is rated for 1.1A average current; the DFSL240L is rated for 2A average current. The average diode current in an LT1936 application is approximately $I_{OUT}(1 - DC)$.

Input Capacitor

Bypass the input of the LT1936 circuit with a 4.7 μF or higher value ceramic capacitor of X7R or X5R type. Y5V types have poor performance over temperature and applied voltage, and should not be used. A 4.7 μF ceramic is adequate to bypass the LT1936 and will easily handle the ripple current. However, if the input power source has high impedance, or there is significant inductance due to long wires or cables, additional bulk capacitance may be necessary. This can be provided with a low performance electrolytic capacitor.

Step-down regulators draw current from the input supply in pulses with very fast rise and fall times. The input capacitor is required to reduce the resulting voltage ripple at the LT1936 and to force this very high frequency switching current into a tight local loop, minimizing EMI. A 4.7 μF capacitor is capable of this task, but only if it is placed close to the LT1936 and the catch diode; see the PCB Layout section. A second precaution regarding the ceramic input capacitor concerns the maximum input voltage rating of the LT1936. A ceramic input capacitor

combined with trace or cable inductance forms a high quality (under damped) tank circuit. If the LT1936 circuit is plugged into a live supply, the input voltage can ring to twice its nominal value, possibly exceeding the LT1936's voltage rating. This situation is easily avoided; see the Hot Plugging Safety section.

For space sensitive applications, a 2.2 μF ceramic capacitor can be used for local bypassing of the LT1936 input. However, the lower input capacitance will result in increased input current ripple and input voltage ripple, and may couple noise into other circuitry. Also, the increased voltage ripple will raise the minimum operating voltage of the LT1936 to ~3.7V.

Output Capacitor

The output capacitor has two essential functions. Along with the inductor, it filters the square wave generated by the LT1936 to produce the DC output. In this role it determines the output ripple, and low impedance at the switching frequency is important. The second function is to store energy in order to satisfy transient loads and stabilize the LT1936's control loop.

Ceramic capacitors have very low equivalent series resistance (ESR) and provide the best ripple performance. A good value is:

$$C_{OUT} = \frac{150}{V_{OUT}}$$

where C_{OUT} is in μF . Use X5R or X7R types. This choice will provide low output ripple and good transient response. Transient performance can be improved with a high value capacitor if the compensation network is also adjusted to maintain the loop bandwidth.

A lower value of output capacitor can be used, but transient performance will suffer. With an external compensation network, the loop gain can be lowered to compensate for the lower capacitor value. When using the internal compensation network, the lowest value for stable operation is:

$$C_{OUT} > \frac{66}{V_{OUT}}$$

APPLICATIONS INFORMATION

Table 2. Capacitor Vendors

VENDOR	PHONE	URL	PART SERIES	COMMENTS
Panasonic	(714) 373-7366	www.panasonic.com	Ceramic, Polymer, Tantalum	EEF Series
Kemet	(864) 963-6300	www.kemet.com	Ceramic, Tantalum	T494, T495
Sanyo	(408) 749-9714	www.sanyovideo.com	Ceramic, Polymer, Tantalum	POSCAP
Murata	(404) 436-1300	www.murata.com	Ceramic	
AVX		www.avxcorp.com	Ceramic, Tantalum	TPS Series
Taiyo Yuden	(864) 963-6300	www.taiyo-yuden.com	Ceramic	

This is the minimum output capacitance required, not the nominal capacitor value. For example, a 3.3V output requires 20 μ F of output capacitance. If a small 22 μ F, 6.3V ceramic capacitor is used, the circuit may be unstable because the effective capacitance is lower than the nominal capacitance when biased at 3.3V. Look carefully at the capacitor's data sheet to find out what the actual capacitance is under operating conditions (applied voltage and temperature). A physically larger capacitor, or one with a higher voltage rating, may be required.

High performance electrolytic capacitors can be used for the output capacitor. Low ESR is important, so choose one that is intended for use in switching regulators. The ESR should be specified by the supplier, and should be 0.05 Ω or less. Such a capacitor will be larger than a ceramic capacitor and will have a larger capacitance, because the capacitor must be large to achieve low ESR. Table 2 lists several capacitor vendors.

Frequency Compensation

The LT1936 uses current mode control to regulate the output. This simplifies loop compensation. In particular, the LT1936 does not require the ESR of the output capacitor for stability, so you are free to use ceramic capacitors to achieve low output ripple and small circuit size.

Frequency compensation is provided by the components tied to the V_C pin, as shown in Figure 1. Generally a capacitor (C_C) and a resistor (R_C) in series to ground are used. In addition, there may be lower value capacitor in parallel.

This capacitor (C_F) is not part of the loop compensation but is used to filter noise at the switching frequency, and is required only if a phase-lead capacitor is used or if the output capacitor has high ESR. An alternative to using external compensation components is to use the internal RC network by tying the COMP pin to the V_C pin. This reduces component count but does not provide the optimum transient response when the output capacitor value is high, and the circuit may not be stable when the output capacitor value is low. If the internal compensation network is not used, tie COMP to ground or leave it floating.

Loop compensation determines the stability and transient performance. Designing the compensation network is a bit

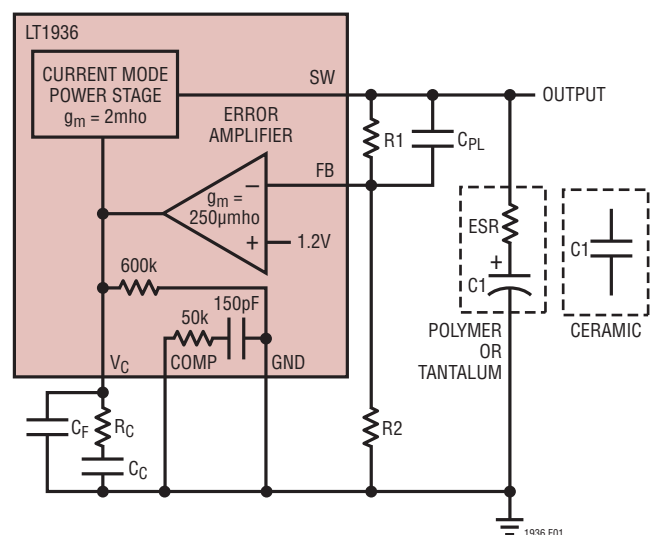

Figure 1. Model for Loop Response

1936fd

APPLICATIONS INFORMATION

complicated and the best values depend on the application and in particular the type of output capacitor. A practical approach is to start with one of the circuits in this data sheet that is similar to your application and tune the compensation network to optimize the performance. Stability should then be checked across all operating conditions, including load current, input voltage and temperature. The LT1375 data sheet contains a more thorough discussion of loop compensation and describes how to test the stability using a transient load.

Figure 1 shows an equivalent circuit for the LT1936 control loop. The error amplifier is a transconductance amplifier with finite output impedance. The power section, consisting of the modulator, power switch and inductor, is modeled as a transconductance amplifier generating an output

current proportional to the voltage at the V_C pin. Note that the output capacitor integrates this current, and that the capacitor on the V_C pin (C_C) integrates the error amplifier output current, resulting in two poles in the loop. In most cases a zero is required and comes from either the output capacitor ESR or from a resistor R_C in series with C_C . This simple model works well as long as the value of the inductor is not too high and the loop crossover frequency is much lower than the switching frequency. A phase lead capacitor (C_{PL}) across the feedback divider may improve the transient response.

Figure 2 compares the transient response across several output capacitor choices and compensation schemes. In each case the load current is stepped from 200mA to 800mA and back to 200mA.

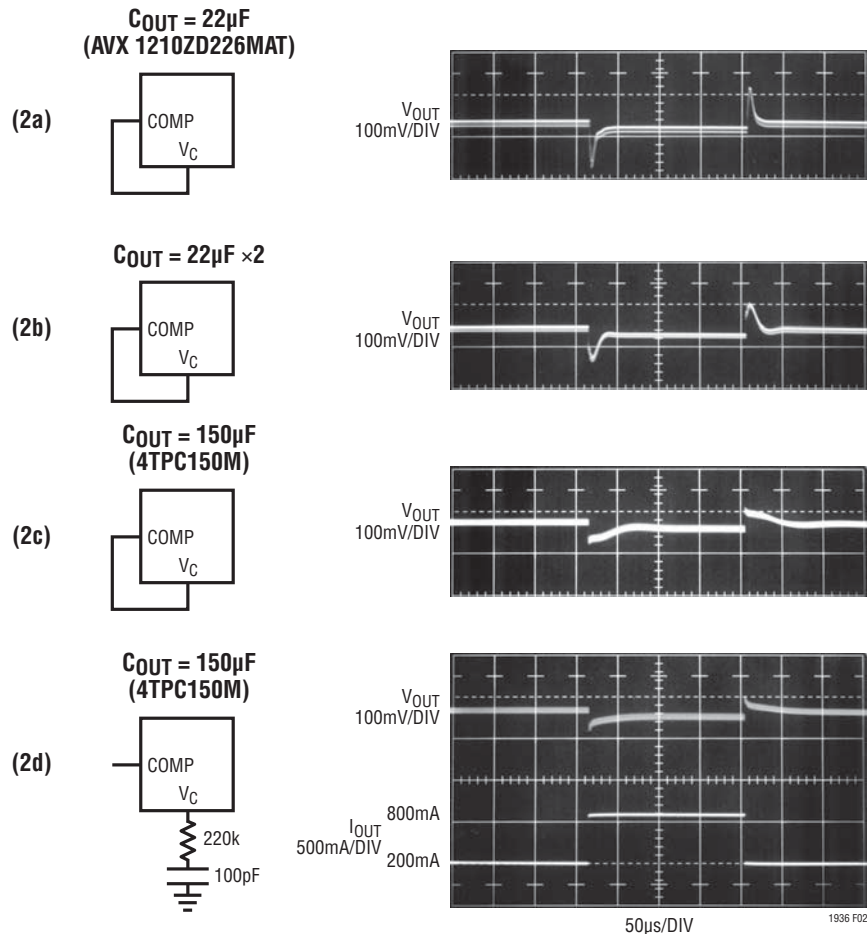

Figure 2. Transient Load Response of the LT1936 with Different Output Capacitors as the Load Current is Stepped from 200mA to 800mA. $V_{OUT} = 3.3V$

APPLICATIONS INFORMATION

BOOST Pin Considerations

Capacitor C3 and diode D2 are used to generate a boost voltage that is higher than the input voltage. In most cases a 0.22 μ F capacitor and fast switching diode (such as the 1N4148 or 1N914) will work well. Figure 3 shows two ways to arrange the boost circuit. The BOOST pin must be at least 2.3V above the SW pin for best efficiency. For outputs of 3V and above, the standard circuit (Figure 3a) is best. For outputs between 2.8V and 3V, use a 0.47 μ F capacitor and a Schottky diode. For lower output voltages the boost diode can be tied to the input (Figure 3b), or to another supply greater than 2.8V. The circuit in Figure 3a is more efficient because the BOOST pin current comes from a lower voltage. You must also be sure that the maximum voltage rating of the BOOST pin is not exceeded.

A 2.5V output presents a special case. This is a popular output voltage, and the advantage of connecting the boost circuit to the output is that the circuit will accept a 36V maximum input voltage rather than 20V (due to the BOOST pin rating). However, 2.5V is marginally adequate to support the boosted drive stage at low ambient temperatures. Therefore, special care and some restrictions on operation are necessary when powering the BOOST pin from a 2.5V output. Minimize the voltage loss in the boost

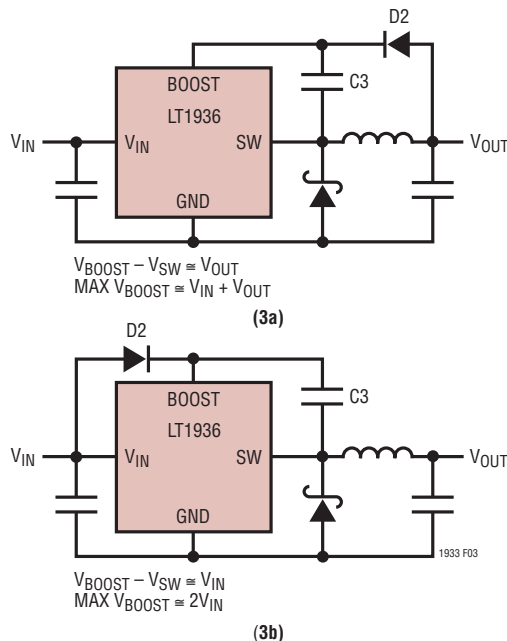

Figure 3. Two Circuits for Generating the Boost Voltage

circuit by using a 1 μ F boost capacitor and a good, low drop Schottky diode (such as the ON Semi MBR0540). Because the required boost voltage increases at low temperatures, the circuit will supply only 1A of output current when the ambient temperature is -45°C , increasing to 1.2A at 0°C . Also, the minimum input voltage to start the boost circuit is higher at low temperature. See the Typical Applications section for a 2.5V schematic and performance curves.

The minimum operating voltage of an LT1936 application is limited by the undervoltage lockout ($\sim 3.45\text{V}$) and by the maximum duty cycle as outlined above. For proper start-up, the minimum input voltage is also limited by the boost circuit. If the input voltage is ramped slowly, or the LT1936 is turned on with its $\overline{\text{SHDN}}$ pin when the output is already in regulation, then the boost capacitor may not be fully charged. Because the boost capacitor is charged with the energy stored in the inductor, the circuit will rely on some minimum load current to get the boost circuit running properly. This minimum load will depend on input and output voltages, and on the arrangement of the boost circuit. The minimum load generally goes to zero once the circuit has started. Figure 4 shows a plot of minimum load to start and to run as a function of input voltage. In many cases the discharged output capacitor will present a load to the switcher, which will allow it to start. The plots show the worst-case situation where V_{IN} is ramping very slowly. For lower start-up voltage, the boost diode can be tied to V_{IN} ; however, this restricts the input range to one-half of the absolute maximum rating of the BOOST pin.

At light loads, the inductor current becomes discontinuous and the effective duty cycle can be very high. This reduces the minimum input voltage to approximately 300mV above V_{OUT} . At higher load currents, the inductor current is continuous and the duty cycle is limited by the maximum duty cycle of the LT1936, requiring a higher input voltage to maintain regulation.

Soft-Start

The $\overline{\text{SHDN}}$ pin can be used to soft-start the LT1936, reducing the maximum input current during start-up. The $\overline{\text{SHDN}}$ pin is driven through an external RC filter to create a voltage ramp at this pin. Figure 5 shows the start-up waveforms with and without the soft-start circuit. By choosing a large

APPLICATIONS INFORMATION

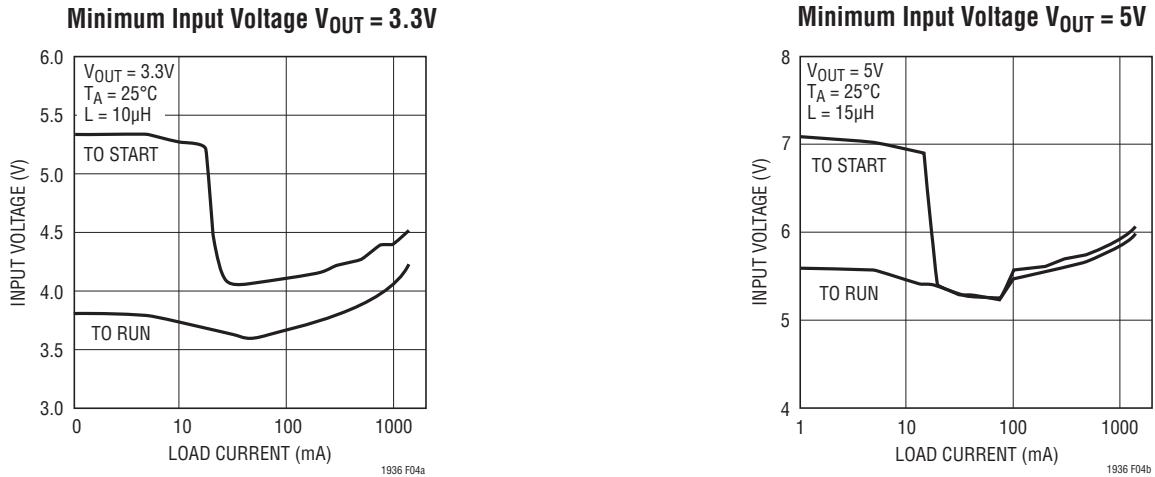

Figure 4. The Minimum Input Voltage Depends on Output Voltage, Load Current and Boost Circuit

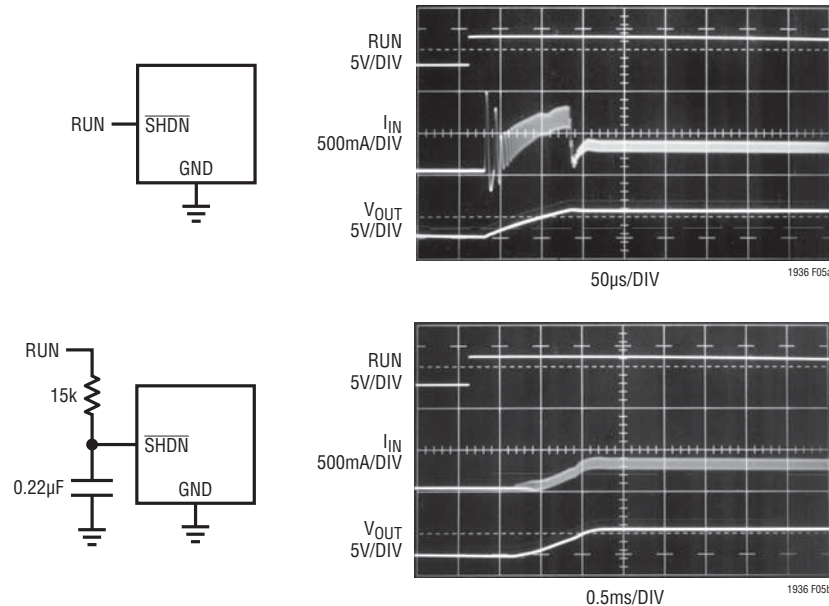

Figure 5. To Soft-Start the LT1936, Add a Resistor and Capacitor to the \overline{SHDN} Pin. $V_{IN} = 12V$, $V_{OUT} = 3.3V$, $C_{OUT} = 2 \times 22\mu F$, $R_{LOAD} = 3.3\Omega$

RC time constant, the peak start-up current can be reduced to the current that is required to regulate the output, with no overshoot. Choose the value of the resistor so that it can supply 60µA when the \overline{SHDN} pin reaches 2.3V.

Shorted and Reversed Input Protection

If the inductor is chosen so that it won't saturate excessively, an LT1936 buck regulator will tolerate a shorted output. There is another situation to consider in systems

where the output will be held high when the input to the LT1936 is absent. This may occur in battery charging applications or in battery backup systems where a battery or some other supply is diode OR-ed with the LT1936's output. If the V_{IN} pin is allowed to float and the \overline{SHDN} pin is held high (either by a logic signal or because it is tied to V_{IN}), then the LT1936's internal circuitry will pull its quiescent current through its SW pin. This is fine if your system can tolerate a few mA in this state. If you ground

APPLICATIONS INFORMATION

the $\overline{\text{SHDN}}$ pin, the SW pin current will drop to essentially zero. However, if the V_{IN} pin is grounded while the output is held high, then parasitic diodes inside the LT1936 can pull large currents from the output through the SW pin and the V_{IN} pin. Figure 6 shows a circuit that will run only when the input voltage is present and that protects against a shorted or reversed input.

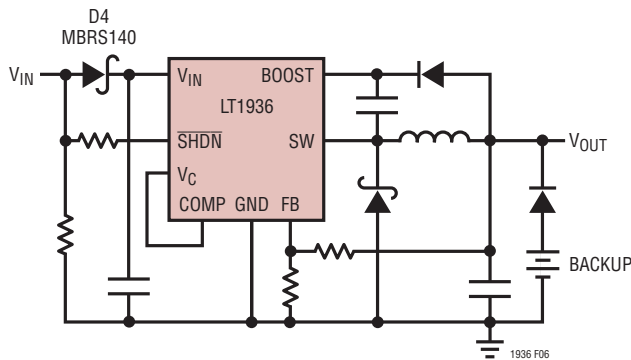

Figure 6. Diode D4 Prevents a Shorted Input from Discharging a Backup Battery Tied to the Output; It Also Protects the Circuit from a Reversed Input. The LT1936 Runs Only When the Input is Present

PCB Layout

For proper operation and minimum EMI, care must be taken during printed circuit board layout. Figure 7 shows the recommended component placement with trace, ground plane and via locations. Note that large, switched currents flow in the LT1936's V_{IN} and SW pins, the catch diode (D1) and the input capacitor (C2). The loop formed by these components should be as small as possible. These components, along with the inductor and output capacitor, should be placed on the same side of the circuit board, and their connections should be made on that layer. Place a local, unbroken ground plane below these components. The SW and BOOST nodes should be as small as possible. Finally, keep the FB and V_{C} nodes small so that the ground traces will shield them from the SW and BOOST nodes. The Exposed Pad on the bottom of the package must be soldered to ground so that the pad acts as a heat sink. To keep thermal resistance low, extend the ground plane as much as possible, and add thermal vias under and near the LT1936 to additional ground planes within the circuit board and on the bottom side.

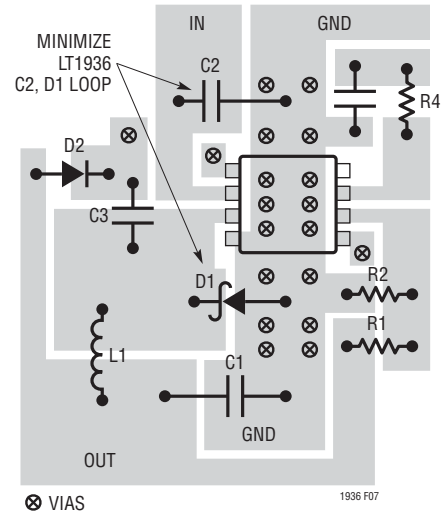

Figure 7. A Good PCB Layout Ensures Low EMI Operation

High Temperature Considerations

The die temperature of the LT1936 must be lower than the maximum rating of 125°C (150°C for the H grade). This is generally not a concern unless the ambient temperature is above 85°C. For higher temperatures, care should be taken in the layout of the circuit to ensure good heat sinking of the LT1936. The maximum load current should be derated as the ambient temperature approaches 125°C (150°C for the H grade).

The die temperature is calculated by multiplying the LT1936 power dissipation by the thermal resistance from junction to ambient. Power dissipation within the LT1936 can be estimated by calculating the total power loss from an efficiency measurement and subtracting the catch diode loss. The resulting temperature rise at full load is nearly independent of input voltage. Thermal resistance depends on the layout of the circuit board, but values from 40°C/W to 60°C/W are typical.

Die temperature rise was measured on a 4-layer, 5cm × 6.5cm circuit board in still air at a load current of 1.4A. For 12V input to 3.3V output the die temperature elevation above ambient was 26°C; for 24V in to 3.3V out the rise was 31°C; for 12V in to 5V the rise was 31°C and for 24V in to 5V the rise was 34°C.

APPLICATIONS INFORMATION

Hot Plugging Safely

The small size, robustness and low impedance of ceramic capacitors make them an attractive option for the input bypass capacitor of LT1936 circuits. However, these capacitors can cause problems if the LT1936 is plugged into a live supply (see Linear Technology Application Note 88 for a complete discussion). The low loss ceramic capacitor combined with stray inductance in series with the power source forms an under damped tank circuit, and the voltage at the V_{IN} pin of the LT1936 can ring to twice the nominal

input voltage, possibly exceeding the LT1936's rating and damaging the part. If the input supply is poorly controlled or the user will be plugging the LT1936 into an energized supply, the input network should be designed to prevent this overshoot.

Figure 8 shows the waveforms that result when an LT1936 circuit is connected to a 24V supply through six feet of 24-gauge twisted pair. The first plot is the response with a 4.7 μ F ceramic capacitor at the input. The input voltage rings as high as 50V and the input current peaks at 26A.

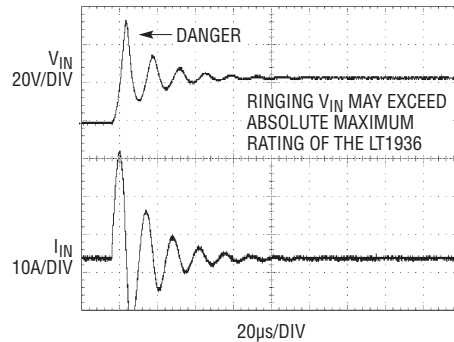
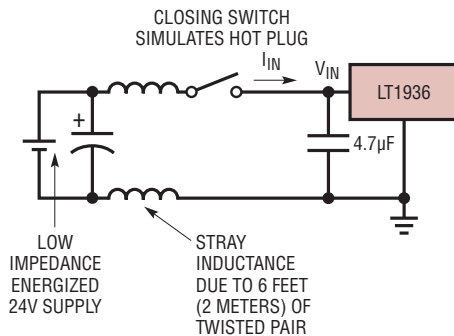

(8a)

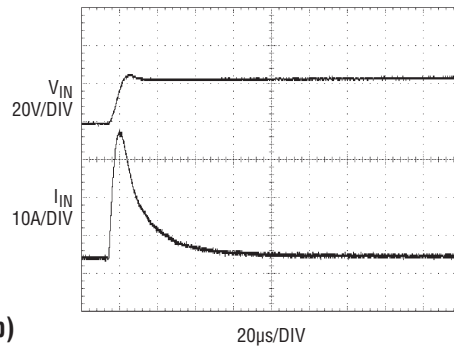
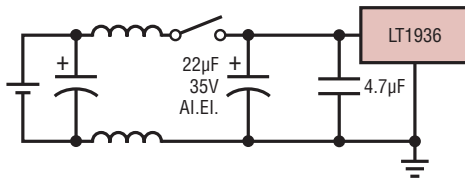

(8b)

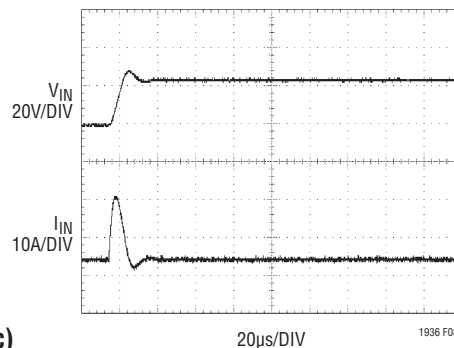
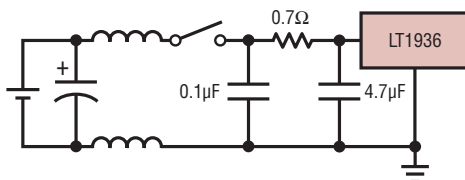

(8c)

Figure 8. A Well Chosen Input Network Prevents Input Voltage Overshoot and Ensures Reliable Operation When the LT1936 is Connected to a Live Supply

APPLICATIONS INFORMATION

One method of damping the tank circuit is to add another capacitor with a series resistor to the circuit. In Figure 8b an aluminum electrolytic capacitor has been added. This capacitor's high equivalent series resistance damps the circuit and eliminates the voltage overshoot. The extra capacitor improves low frequency ripple filtering and can slightly improve the efficiency of the circuit, though it is likely to be the largest component in the circuit. An alternative solution is shown in Figure 8c. A 0.7Ω resistor is added in series with the input to eliminate the voltage overshoot (it also reduces the peak input current). A $0.1\mu\text{F}$ capacitor improves high frequency filtering. This solution is smaller and less expensive than the electrolytic capacitor. For high input voltages its impact on efficiency is minor, reducing efficiency by one percent for a 5V output at full load operating from 24V.

Other Linear Technology Publications

Application Notes 19, 35 and 44 contain more detailed descriptions and design information for buck regulators and other switching regulators. The LT1376 data sheet has a more extensive discussion of output ripple, loop compensation and stability testing. Design Note 100 shows how to generate a bipolar output supply using a buck regulator.

Outputs Greater Than 6V

For outputs greater than 6V, add a resistor of 1k to 2.5k across the inductor to damp the discontinuous ringing of the SW node, preventing unintended SW current. The 12V Step-Down Converter circuit in the Typical Applications section shows the location of this resistor. Also note that for outputs above 6V, the input voltage range will be limited by the maximum rating of the BOOST pin. The 12V circuit shows how to overcome this limitation using an additional Zener diode.

TYPICAL APPLICATIONS

3.3V Step-Down Converter

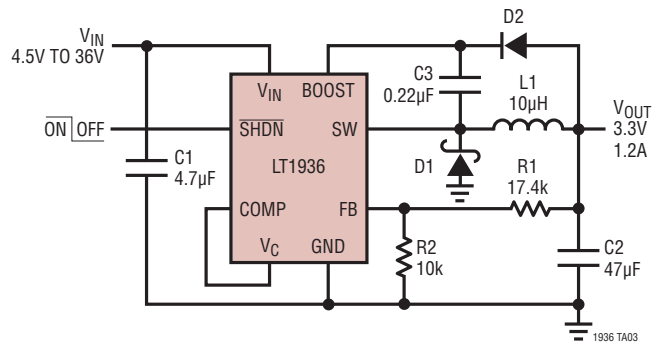

TYPICAL APPLICATIONS

5V Step-Down Converter

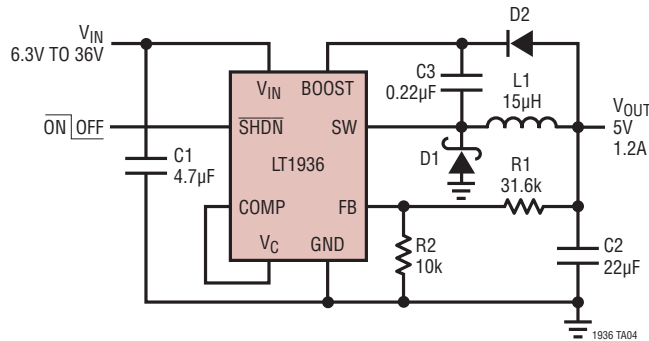

1.8V Step-Down Converter

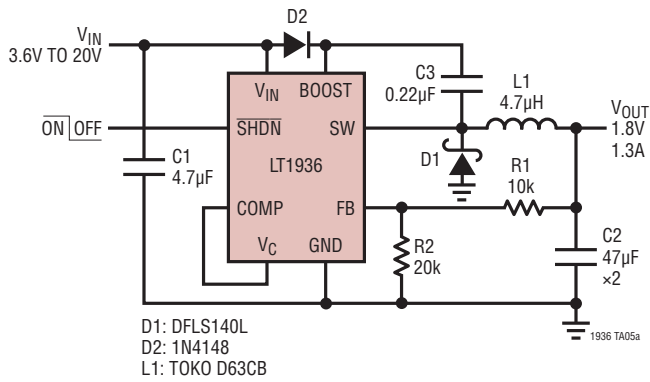

Efficiency, 1.8V Output

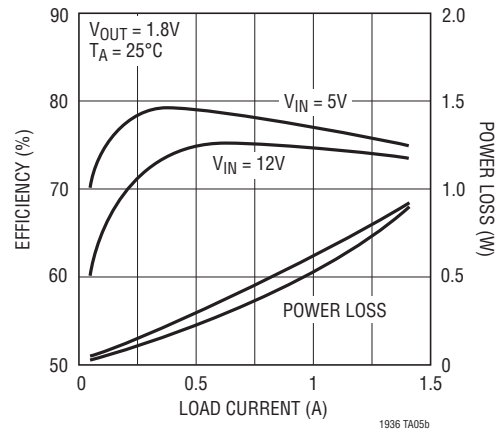

1.2V Step-Down Converter

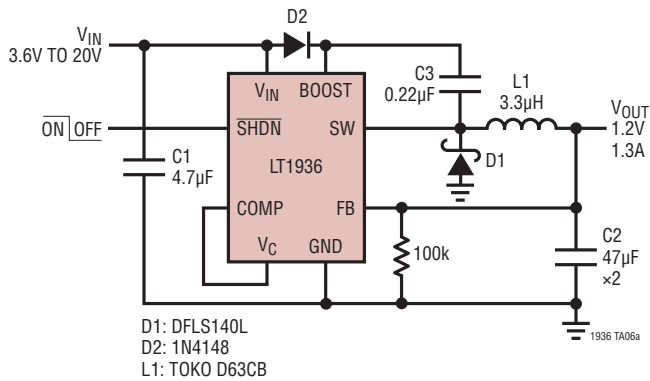

Efficiency, 1.2V Output

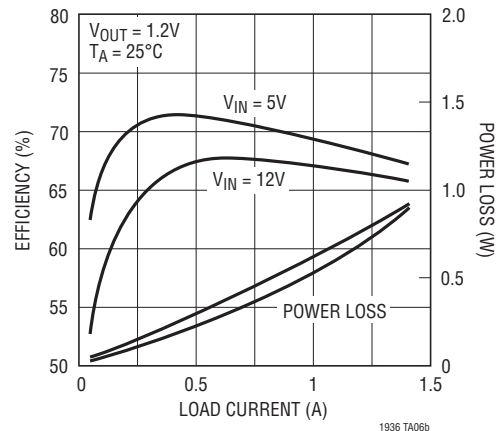

TYPICAL APPLICATIONS

2.5V Step-Down Converter

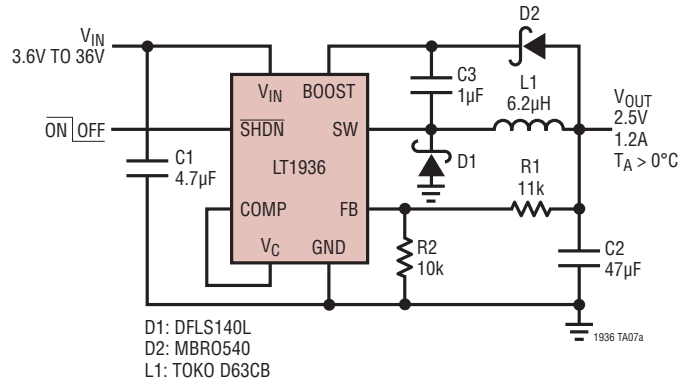

Efficiency, 2.5V Output

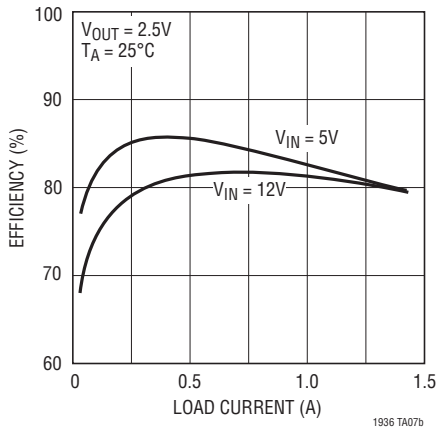

Minimum Input Voltage

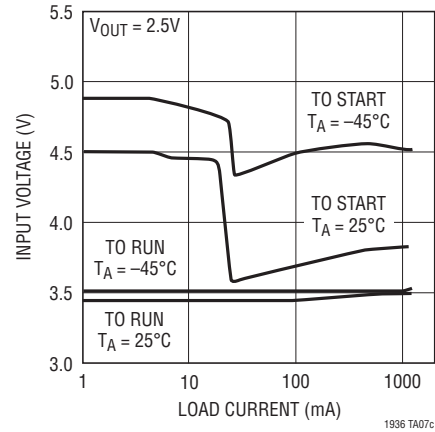

12V Step-Down Converter

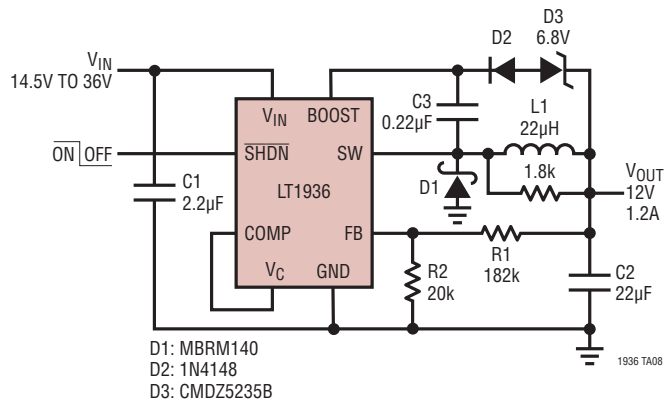

PACKAGE DESCRIPTION

MS8E Package 8-Lead Plastic MSOP, Exposed Die Pad (Reference LTC DWG # 05-08-1662 Rev E)

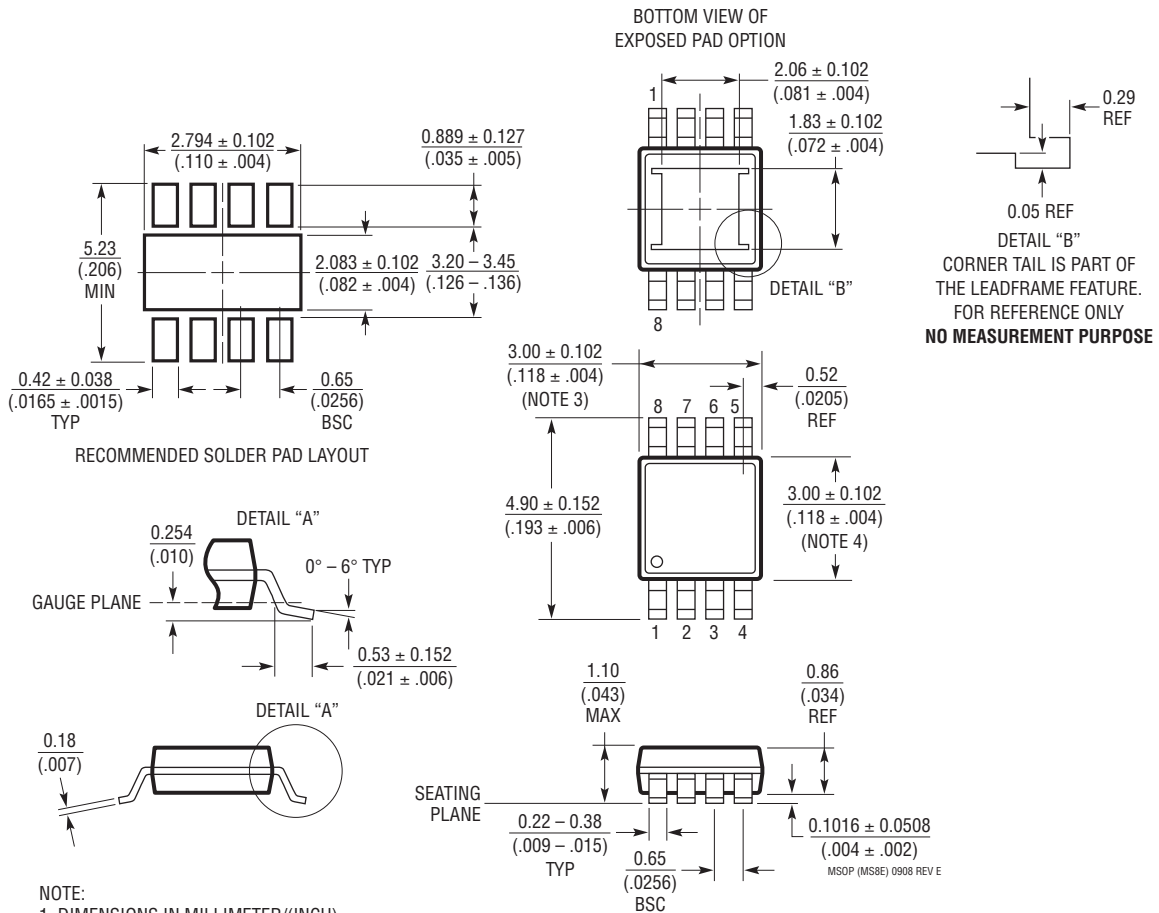

- NOTE:
1. DIMENSIONS IN MILLIMETER/(INCH)
 2. DRAWING NOT TO SCALE
 3. DIMENSION DOES NOT INCLUDE MOLD FLASH, PROTRUSIONS OR GATE BURRS. MOLD FLASH, PROTRUSIONS OR GATE BURRS SHALL NOT EXCEED 0.152mm (.006") PER SIDE
 4. DIMENSION DOES NOT INCLUDE INTERLEAD FLASH OR PROTRUSIONS. INTERLEAD FLASH OR PROTRUSIONS SHALL NOT EXCEED 0.152mm (.006") PER SIDE
 5. LEAD COPLANARITY (BOTTOM OF LEADS AFTER FORMING) SHALL BE 0.102mm (.004") MAX

TYPICAL APPLICATION

2.5V Step-Down Converter

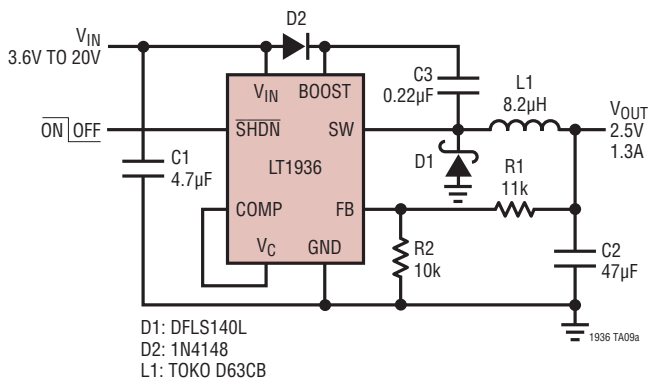

Minimum Input Voltage

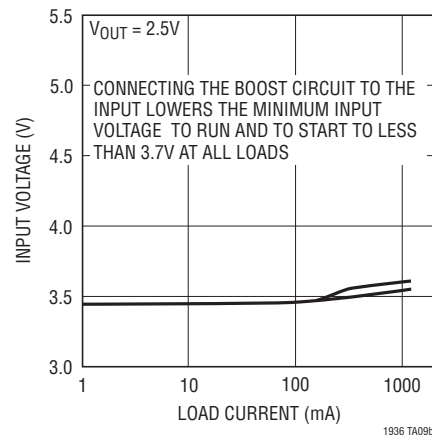

RELATED PARTS

PART NUMBER	DESCRIPTION	COMMENTS
LT1676	60V, 440mA (I_{OUT}), 100kHz, High Efficiency Step-Down DC/DC Converter	V_{IN} : 7.4V to 60V, $V_{OUT(MIN)}$ = 1.24V, I_Q = 3.2mA, I_{SD} = 2.5µA, SO-8 Package
LT1765	25V, 2.75A (I_{OUT}), 1.25MHz, High Efficiency Step-Down DC/DC Converter	V_{IN} : 3V to 25V, $V_{OUT(MIN)}$ = 1.20V, I_Q = 1mA, I_{SD} = 15µA, SO-8 and 16-Lead TSSOPE Packages
LT1766	60V, 1.2A (I_{OUT}), 200kHz, High Efficiency Step-Down DC/DC Converter	V_{IN} : 5.5V to 60V, $V_{OUT(MIN)}$ = 1.20V, I_Q = 2.5mA, I_{SD} = 25µA, 16-Lead TSSOP/TSSOPE Packages
LT1767	25V, 1.2A (I_{OUT}), 1.25MHz, High Efficiency Step-Down DC/DC Converter	V_{IN} : 3V to 25V, $V_{OUT(MIN)}$ = 1.20V, I_Q = 1mA, I_{SD} = 6µA, MS8/MS8E Packages
LT1776	40V, 550mA (I_{OUT}), 200kHz, High Efficiency Step-Down DC/DC Converter	V_{IN} : 7.4V to 40V, $V_{OUT(MIN)}$ = 1.24V, I_Q = 3.2mA, I_{SD} = 30µA, N8/SO-8 Packages
LT1933	600mA, 500kHz, Step-Down Switching Regulator in SOT-23	V_{IN} : 3.6V to 36V, $V_{OUT(MIN)}$ = 1.25V, I_Q = 1.6mA, I_{SD} < 1µA, ThinSOT™ Package
LT1940	25V, Dual 1.4A (I_{OUT}), 1.1MHz, High Efficiency Step-Down DC/DC Converter	V_{IN} : 3V to 25V, $V_{OUT(MIN)}$ = 1.2V, I_Q = 3.8mA, I_{SD} < 1µA, 16-Lead TSSOPE Package
LT1956	60V, 1.2A (I_{OUT}), 500kHz, High Efficiency Step-Down DC/DC Converter	V_{IN} : 5.5V to 60V, $V_{OUT(MIN)}$ = 1.20V, I_Q = 2.5mA, I_{SD} = 25µA, 16-Lead TSSOP/TSSOPE Packages
LT1976	60V, 1.2A (I_{OUT}), 200kHz, High Efficiency Step-Down DC/DC Converter with Burst Mode® Operation	V_{IN} : 3.3V to 60V, $V_{OUT(MIN)}$ = 1.20V, I_Q = 100µA, I_{SD} < 1µA, 16-Lead TSSOPE Package
LT3010	80V, 50mA, Low Noise Linear Regulator	V_{IN} : 1.5V to 80V, $V_{OUT(MIN)}$ = 1.28V, I_Q = 30µA, I_{SD} < 1µA, MS8E Package
LTC®3407	Dual 600mA (I_{OUT}), 1.5MHz, Synchronous Step-Down DC/DC Converter	V_{IN} : 2.5V to 5.5V, $V_{OUT(MIN)}$ = 0.6V, I_Q = 40µA, I_{SD} < 1µA, 10-Lead MSE Package
LTC3412	2.5A (I_{OUT}), 4MHz, Synchronous Step-Down DC/DC Converter	V_{IN} : 2.5V to 5.5V, $V_{OUT(MIN)}$ = 0.8V, I_Q = 60µA, I_{SD} < 1µA, 16-Lead TSSOPE Package
LTC3414	4A (I_{OUT}), 4MHz, Synchronous Step-Down DC/DC Converter	V_{IN} : 2.3V to 5.5V, $V_{OUT(MIN)}$ = 0.8V, I_Q = 64µA, I_{SD} < 1µA, 20-Lead TSSOPE Package
LT3430/LT3431	60V, 2.75A (I_{OUT}), 200kHz/500kHz, High Efficiency Step-Down DC/DC Converters	V_{IN} : 5.5V to 60V, $V_{OUT(MIN)}$ = 1.20V, I_Q = 2.5mA, I_{SD} = 30µA, 16-Lead TSSOPE Package

Burst Mode is a registered trademark of Linear Technology Corporation. ThinSOT is a trademark of Linear Technology Corporation.

Looking for pricing, stock, or lifecycle information?

Click below to explore more details on WIN SOURCE:

 [View LT1936EMS8E#PBF on WIN SOURCE](#)

 [Linear Technology](#) Information

Optimize Your Supply Chain with WIN SOURCE Solutions

-  Global Sourcing Solution
-  Obsolete Management
-  Cost Control Management
-  Shortage Management
-  Alternative Solution
-  Excess Inventory Management