



**THE DATASHEET OF
LT3022EMSE#TRPBF**



General Description

The ST16C554, ST16C554D and ST68C554 are each quad Universal Asynchronous Receivers and Transmitters (UARTs) with 16 bytes of transmit and receive FIFOs, selectable receive FIFO trigger levels, and data rates of up to 1.5Mbps. Each UART has a set of registers that provide the user with operating status and control, receiver error indications, and modem serial interface controls. An internal loopback capability allows onboard diagnostics. The ST16C554 is available in a 64-pin LQFP package, the ST16C554D is available in both a 64-pin LQFP and a 68-pin PLCC package, and the ST68C554 is available in a 68-pin PLCC package. The 64-pin package only offers the 16 mode interface, but the 68-pin package offers an additional 68 mode interface which allows easy integration with Motorola processors. The ST16C554CQ64 (64-pin) offers three-state interrupt output while the ST16C554DCQ64 provides continuous interrupt output. The ST16C554 and ST16C554D combine the package interface modes of the 16C554 and 68C554 on a single integrated chip.

Ordering Information - [page 32](#)

Features

- Pin-to-pin compatible with the industry standard ST16C454, ST68C454, ST68C554, TI's TL16C554A and Philips' SC16C554B
- Intel or Motorola data bus interface select
- Four independent UART channels
 - Register set compatible to 16C550
 - Data rates of up to 1.5Mbps at 5V
 - Data rates of up to 500kbps at 3.3V
 - 16 byte transmit FIFO
 - 16 byte receive FIFO with error tags
 - 4 selectable RX FIFO trigger levels
 - Full modem interface
- 2.97V to 5.5V supply operation
- Crystal oscillator or external clock input

Applications

- Portable appliances
- Telecommunication network routers
- Ethernet network routers
- Cellular data devices
- Factory automation and process controls

Block Diagram

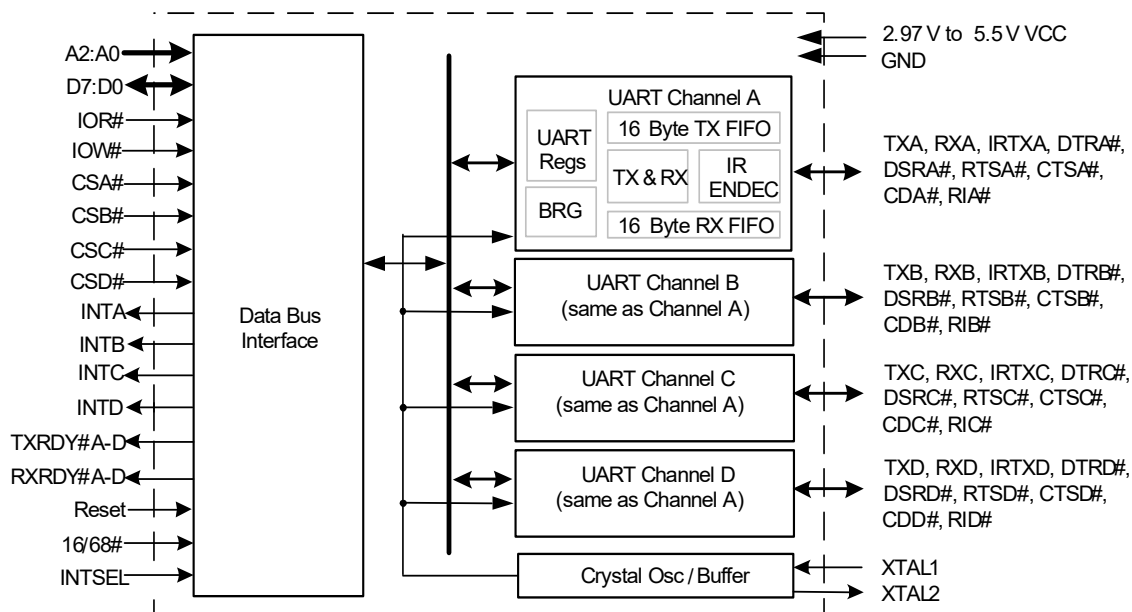

Figure 1: ST16C554 Block Diagram

Revision History

Document No.	Release Date	Change Description
3.3.0	August 2004	Added Revision History and Device Status.
3.3.1	August 2005	Updated the 1.4mm-thick Quad Flat Pack package description from "TQFP" to "LQFP" to be consistent with JEDEC and Industry norms.
4.0.0	April 2006	New datasheet format. Changed active low signal designator from "-" in front of signal name to "#" after signal name. Updated AC Electrical Characteristics.
4.0.1	June 2006	Corrected Part Numbers in Ordering Information.
4.0.2	9/4/19	Update to MaxLinear format. Update Ordering Information and moved to end. Correct pin configuration with selectable 16/68# pin from ST16C554 to ST16C554D.

Table of Contents

General Description	i
Features	i
Applications	i
Block Diagram	i
1.0 Pin Information	1
1.1 Pin Descriptions	2
2.0 Product Description	5
2.1 Enhanced FIFO	5
2.2 Intel or Motorola Data Bus Interface	5
2.3 Data Rate	5
2.4 Enhanced Features	5
3.0 Functional Descriptions	6
3.1 CPU Interface	6
3.2 Device Reset	7
3.3 Channel Selection	7
3.4 Internal Registers of Channels A - D	7
3.5 INT Outputs for Channels A - D	7
3.6 DMA Mode	8
3.7 Crystal Oscillator or External Clock Input	8
3.8 Programmable Baud Rate Generator	9
3.9 Transmitter	10
3.9.1 Transmit Holding Register (THR) - Write Only	10
3.9.2 Transmitter Operation in Non-FIFO Mode	10
3.9.3 Transmitter Operation in FIFO Mode	10
3.10 Receiver	10
3.10.1 Receive Holding Register (RHR) - Read Only	11
3.11 Internal Loopback	12
4.0 UART Internal Registers	13
5.0 Internal Register Descriptions	15
5.1 Receive Holding Register (RHR) - Read-Only	15
5.2 Transmit Holding Register (THR) - Write-Only	15
5.3 Interrupt Enable Register (IER) - Read and Write	15
5.3.1 IER Versus Receive FIFO Interrupt Mode Operation	15
5.3.2 IER Versus Receive and Transmit FIFO Polled Mode Operation	15

5.4 Interrupt Status Register (ISR)	16
5.4.1 Interrupt Generation	16
5.4.2 Interrupt Clearing.....	16
5.5 FIFO Control Register (FCR) - Write-Only	17
5.6 Line Control Register (LCR) - Read and Write	17
5.7 Modem Control Register (MCR) or General Purpose Output Control - Read and Write	18
5.8 Line Status Register (LSR) - Read and Write.....	19
5.9 Modem Status Register (MSR) - Read and Write	20
5.10 Scratch Pad Register (SPR) - Read and Write.....	20
5.11 Baud Rate Generator Registers (DLL and DLM) - Read and Write	21
6.0 Specifications	22
6.1 Absolute Maximum Ratings.....	22
6.2 Electrical Characteristics	22
6.2.1 DC Electrical Characteristics	22
6.2.2 AC Electrical Characteristics	23
7.0 Mechanical Dimensions	30
7.1 LQFP64	30
7.2 PLCC68.....	31
8.0 Ordering Information.....	32

List of Figures

Figure 1: ST16C554 Block Diagram	i
Figure 2: PLCC68 Pinout, Intel Mode	1
Figure 3: PLCC68 Pinout, Motorola Mode	1
Figure 4: LQFP64 Pinout, Intel Mode Only	1
Figure 5: PLCC68 Pinout, Motorola Mode Only	1
Figure 6: ST16C554D Typical Intel and Motorola Data Bus Interconnections	6
Figure 7: Typical Crystal Connections	8
Figure 8: Baud Rate Generator	9
Figure 9: Transmitter Operation in Non-FIFO Mode	10
Figure 10: Transmitter Operation in FIFO Mode	10
Figure 11: Receiver Operation in Non-FIFO Mode	11
Figure 12: Receiver Operation in FIFO Mode	11
Figure 13: Internal Loopback in Channels A and B	12
Figure 14: Clock Timing	24
Figure 15: Modem Input and Output Timing for Channels A - D	24
Figure 16: 16 Mode (Intel) Data Bus Read Timing for Channels A - D	25
Figure 17: 16 Mode (Intel) Data Bus Write Timing for Channels A - D	25
Figure 18: 68 Mode (Motorola) Data Bus Read Timing for Channels A - D	26
Figure 19: 68 Mode (Motorola) Data Bus Write Timing for Channels A - D	26
Figure 20: Receive Ready and Interrupt Timing (Non-FIFO Mode) for Channels A - D	27
Figure 21: Transmit Ready and Interrupt Timing (Non-FIFO Mode) for Channels A - D	27
Figure 22: Receive Ready and Interrupt Timing (FIFO Mode, DMA Disabled) for Channels A - D	28
Figure 23: Receive Ready and Interrupt Timing (FIFO Mode, DMA Enabled) for Channels A - D	28
Figure 24: Transmit Ready and Interrupt Timing (FIFO Mode, DMA Disabled) for Channels A - D	29
Figure 25: Transmit Ready and Interrupt Timing (FIFO Mode, DMA Enabled) for Channels A - D	29
Figure 26: Mechanical Dimension, LQFP64 (10 x 10 x 1.4mm Low-Profile Quad Flat Pack)	30
Figure 27: Mechanical Dimensions, PLCC68 (Plastic Leaded Chip Carrier)	31

List of Tables

Table 1: ST16C554D Pin Descriptions	2
Table 2: Channel A - D Select in 16 Mode	7
Table 3: Channel A - D Select in 68 Mode	7
Table 4: INT Pin Operation for Channel A - D Transmitters	7
Table 5: INT Pin Operation for Channel A - D Receivers	8
Table 6: TXRDY# and RXRDY# Outputs in FIFO and DMA Mode for Channels A - D	8
Table 7: Typical Data Rates with a 14.7456MHz Crystal or External Clock	9
Table 8: Internal Registers of UART Channels A and B	13
Table 9: Internal Register Descriptions	14
Table 10: Interrupt Source and Priority Level	16
Table 11: Receive FIFO Trigger Level Selection	17
Table 12: TX and RX Word Length	17
Table 13: TX and RX Stop-Bit Length	17
Table 14: Parity Selection	18
Table 15: INT Output Modes	19
Table 16: UART Reset Conditions for Channels A - D	21
Table 17: Absolute Maximum Ratings	22
Table 18: Typical Package Thermal Resistance Data	22
Table 19: Electrical Characteristics	22
Table 20: AC Electrical Characteristics	23
Table 21: Ordering Information	32

1.0 Pin Information

1.1 Pin Configurations

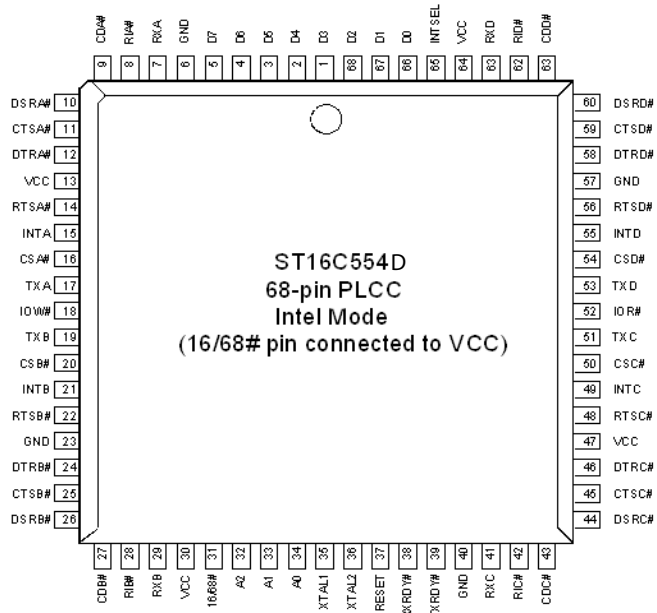

Figure 2: PLCC68 Pinout, Intel Mode

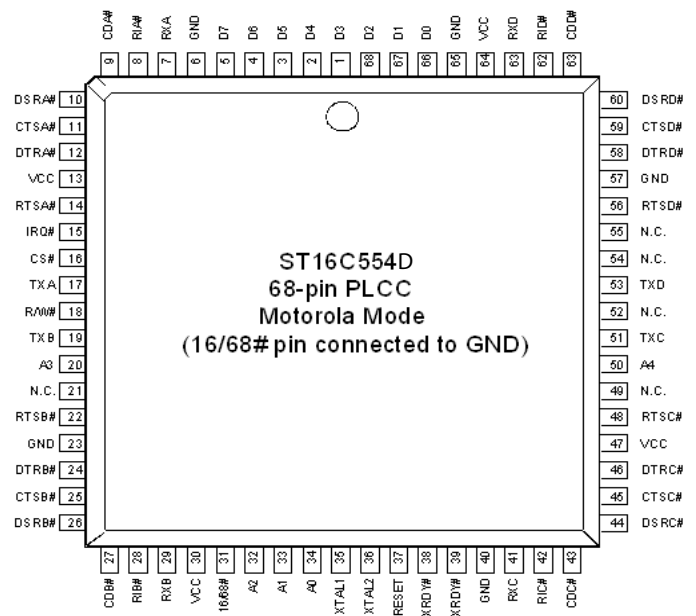

Figure 3: PLCC68 Pinout, Motorola Mode

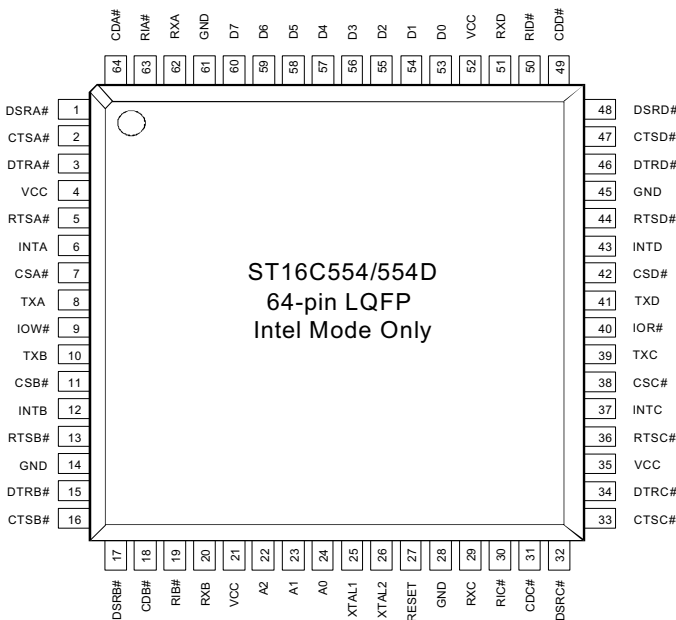

Figure 4: LQFP64 Pinout, Intel Mode Only

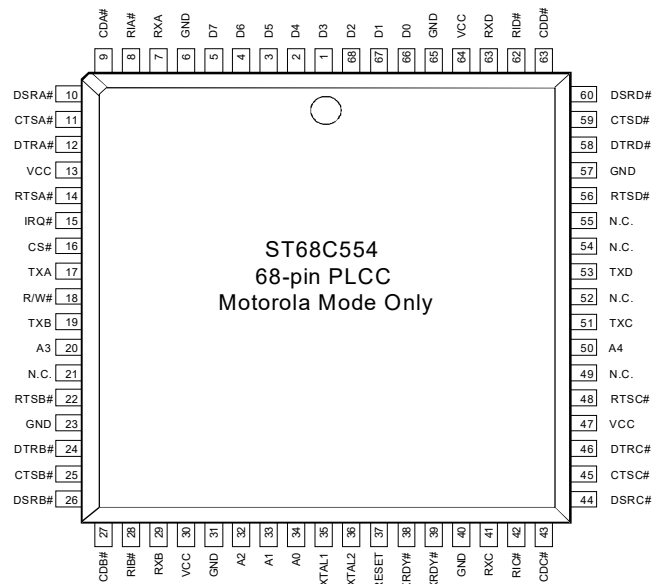

Figure 5: PLCC68 Pinout, Motorola Mode Only

1.2 Pin Descriptions

Table 1: Pin Descriptions

Name	LQFP64	PLCC68	Type	Description
Data Bus Interface				
A2	22	32	I	Address data lines [2:0]. These 3 address lines select one of the internal registers in UART channel A - D during a data bus transaction.
A1	23	33		
A0	24	34		
D7	60	5	I/O	Data bus lines [7:0] (bidirectional).
D6	59	4		
D5	58	3		
D4	57	2		
D3	56	1		
D2	55	68		
D1	54	67		
D0	53	66		
IOR# (VCC)	40	52	I	When the 16/68# pin is HIGH, the Intel bus interface is selected and this input becomes a read strobe (active low). The falling edge instigates an internal read cycle and retrieves the data byte from an internal register pointed to by the address lines [A2:A0], puts the data byte on the data bus to allow the host processor to read it on the rising edge. When the 16/68# pin is LOW, the Motorola bus interface is selected and this input is not used and should be connected to VCC.
IOW# (R/W#)	9	18	I	When the 16/68# pin is HIGH, it selects the Intel bus interface and this input becomes a write strobe (active low). The falling edge instigates the internal write cycle and the rising edge transfers the data byte on the data bus to an internal register pointed to by the address lines. When the 16/68# pin is LOW, the Motorola bus interface is selected and this input becomes read (HIGH) and write (LOW) signal.
CSA# (CS#)	7	16	I	When the 16/68# pin is HIGH, this input is chip select A (active low) to enable channel A in the device. When the 16/68# pin is LOW, this input becomes the chip select (active low) for the Motorola bus interface.
CSB# (A3)	11	20	I	When the 16/68# pin is HIGH, this input is chip select B (active low) to enable channel B in the device. When the 16/68# pin is LOW, this input becomes address line A3 which is used for channel selection in the Motorola bus interface.
CSC# (A4)	38	50	I	When the 16/68# pin is HIGH, this input is chip select C (active low) to enable channel C in the device. When the 16/68# pin is LOW, this input becomes address line A4 which is used for channel selection in the Motorola bus interface.
CSD# (VCC)	42	54	I	When the 16/68# pin is HIGH, this input is chip select D (active low) to enable channel D in the device. When the 16/68# pin is LOW, this input is not used and should be connected to VCC.

Table 1: (Continued) Pin Descriptions

Name	LQFP64	PLCC68	Type	Description
INTA (IRQ#)	6	15	O (OD)	When the 16/68# pin is HIGH for Intel bus interface, this output becomes the channel A interrupt output. The output state is defined by the user and through the software setting of MCR[3]. INTA is set to the active mode when MCR[3] is set to a logic 1. INTA is set to the three state mode when MCR[3] is set to a logic 0 (default). See MCR[3]: INT Output Enable . When the 16/68# pin is LOW for Motorola bus interface, this output becomes the device interrupt output (active low, open drain). An external pull-up resistor is required for proper operation.
INTB (N.C.)	12	21	O	When the 16/68# pin is HIGH for Intel bus interface, these outputs become the interrupt outputs for channels B, C, and D. The output state is defined by the user through the software setting of MCR[3]. The interrupt outputs are set to the active mode when MCR[3] is set to a logic 1 and are set to the three state mode when MCR[3] is set to a logic 0 (default). See MCR[3]: INT Output Enable . When 16/68# pin is LOW for Motorola bus interface, these outputs are unused and will stay at logic zero level. Leave these outputs unconnected.
INTC (N.C.)	37	49		
INTD (N.C.)	43	55		
INTSEL	-	65	I	Interrupt Select (active high, input with internal pull-down). When the 16/68# pin is HIGH for Intel bus interface, this pin can be used in conjunction with MCR bit-3 to enable or disable the INT A - D pins or override MCR bit-3 and enable the interrupt outputs. Interrupt outputs are enabled continuously when this pin is HIGH. MCR bit-3 enables and disables the interrupt output pins. In this mode, MCR bit-3 is set to a logic 1 to enable the continuous output. See MCR[3]: INT Output Enable description for full detail. <u>This pin must be LOW in the Motorola bus interface mode.</u> For the 64 pin packages, this pin is bonded to VCC internally in the ST16C554DCQ64-F so the INT outputs operate in the continuous interrupt mode. This pin is bonded to GND internally in the ST16C554CQ64 and therefore requires setting MCR bit-3 for enabling the interrupt output pins.
TXRDY#	-	39	O	Transmitter Ready (active low). This output is a logically ANDed status of TXRDY# A - D. See Table 6 . If this output is unused, leave it unconnected.
RXRDY#	-	38	O	Receiver Ready (active low). This output is a logically ANDed status of RXRDY# A - D. See Table 6 . If this output is unused, leave it unconnected.
Modem or Serial I/O Interface				
TXA	8	17	O	UART channels A - D transmit data and infrared transmit data. In this mode, the TX signal will be HIGH during reset, or idle (no data).
TXB	10	19		
TXC	39	51		
TXD	41	53		
RXA	62	7	I	UART channel A - D receive data. Normal receive data input must idle HIGH.
RXB	20	29		
RXC	29	41		
RXD	51	63		
RTSA#	5	14	O	UART channels A - D Request-to-Send (active low) or general purpose output. If these outputs are not used, leave them unconnected.
RTSB#	13	22		
RTSC#	36	48		
RTSD#	44	56		
CTSA#	2	11	I	UART channels A - D Clear-to-Send (active low) or general purpose input. These inputs should be connected to VCC when not used.
CTSB#	16	25		
CTSC#	33	45		
CTSD#	47	59		

Table 1: (Continued) Pin Descriptions

Name	LQFP64	PLCC68	Type	Description
DTRA#	3	12	O	UART channels A - D Data-Terminal-Ready (active low) or general purpose output. If these outputs are not used, leave them unconnected.
DTRB#	15	24		
DTRC#	34	46		
DTRD#	46	58		
DSRA#	1	10	I	UART channels A - D Data-Set-Ready (active low) or general purpose input. This input should be connected to VCC when not used. This input has no effect on the UART.
DSRB#	17	26		
DSRC#	32	44		
DSRD#	48	60		
CDA#	64	9	I	UART channels A-D Carrier-Detect (active low) or general purpose input. This input should be connected to VCC when not used. This input has no effect on the UART.
CDB#	18	27		
CDC#	31	43		
CDD#	49	61		
RIA#	63	8	I	UART channels A-D Ring-Indicator (active low) or general purpose input. This input should be connected to VCC when not used. This input has no effect on the UART.
RIB#	19	28		
RIC#	30	42		
RID#	50	62		
Ancillary Signals				
XTAL1	25	35	I	Crystal or external clock input.
XTAL2	26	36	O	Crystal or buffered clock output.
16/68#	-	31	I	Intel or Motorola bus select (input with internal pull-up). When the 16/68# pin is HIGH for 16 or Intel Mode, the device will operate in the Intel bus type of interface. When the 16/68# pin is LOW for 68 or Motorola Mode, the device will operate in the Motorola bus type of interface. Motorola bus interface is not available on the 64 pin package.
RESET (RESET#)	27	37	I	When the 16/68# pin is HIGH for Intel bus interface, this input becomes the Reset pin (active high). In this case, a 40ns minimum HIGH pulse on this pin will reset the internal registers and all outputs. The UART transmitter output will be held HIGH, the receiver input will be ignored, and outputs are reset during the reset period (Table 16). When the 16/68# pin is at LOW for Motorola bus interface, this input becomes the Reset# pin (active low). This pin functions similarly, but instead of a HIGH pulse, a 40ns minimum LOW pulse will reset the internal registers and outputs. Motorola bus interface is not available on the 64 pin package.
VCC	4, 21, 35, 52	13, 30, 47, 64	Pwr	2.97V to 5.5V power supply.
GND	14, 28, 45, 61	6, 23, 40, 57	Pwr	Power supply common, ground.
N.C.	-	-		No connection. These pins are not used in either the Intel or Motorola bus modes.

Pin type: I = Input, O = Output, I/O = Input / Output, OD = Output, Open Drain.

2.0 Product Description

The ST16C554 integrates the functions of 4 enhanced 16C550 Universal Asynchronous Receiver and Transmitters (UARTs). Each UART is independently controlled and has its own set of device configuration registers. The configuration registers set is 16550 UART compatible for control, status, and data transfer. Additionally, each UART channel has 16 bytes of transmit and receive FIFOs, a programmable baud rate generator and data rate up to 1.5Mbps at 5V. The ST16C554 can operate from 2.97 to 5.5 volts. The ST16C554 is fabricated with an advanced CMOS process.

2.1 Enhanced FIFO

The ST16C554 QUART provides a solution that supports 16 bytes of transmit and receive FIFO memory, instead of one byte in the ST16C454. The ST16C554 is designed to work with high performance data communication systems that require fast data processing time. Increased performance is realized in the ST16C554 by the larger transmit and receive FIFOs and receiver FIFO trigger level control. This allows the external processor to handle more networking tasks within a given time. This increases the service interval giving the external CPU additional time for other applications and reducing the overall UART interrupt servicing time.

2.2 Intel or Motorola Data Bus Interface

The ST16C554 provides a single host interface for all 4 UARTs and supports Intel or Motorola microprocessor (CPU) data bus interfaces. The Intel bus compatible interface allows direct interconnect to Intel compatible type of CPUs using IOR#, IOW# and CSA#, CSB#, CSC# and CSD# inputs for data bus operation. The Motorola bus compatible interface instead uses the R/W#, CS#, A3 and A4 signals for data bus transactions. Few data bus interface signals change their functions depending on the user's selection, see pin description for details. The Intel or Motorola bus interface selection is made through the 16/68# (pin 31 of the PLCC package).

2.3 Data Rate

The ST16C554 is capable of operation up to 1.5 Mbps at 5V. The device can operate at 5V with a crystal or external clock of up to 24MHz. With a typical crystal of 14.7456MHz and through a software option, the user can set the sampling rate for data rates of up to 921.6kbps.

2.4 Enhanced Features

The rich feature set of the ST16C554 is available through the internal registers. Selectable receive FIFO trigger levels, programmable baud rates, infrared encoder and decoder interface, and modem interface controls are all standard features. In the 16 mode, INTSEL and MCR bit-3 can be configured to provide a software controlled or continuous interrupt capability. For backward compatibility to the ST16C554, the 64-pin LQFP does not have the INTSEL pin. Instead, the ST16C554DIQ and ST16C554DCQ operate in the continuous interrupt enable mode by internally bonding INTSEL to VCC. The ST16C554CQ operates in conjunction with MCR bit-3 by internally bonding INTSEL to GND.

3.0 Functional Descriptions

3.1 CPU Interface

The CPU interface is 8 data bits wide with 3 address lines and control signals to execute data bus read and write transactions. The ST16C554 data interface supports the Intel compatible types of CPUs and it is compatible to the industry standard 16C550 UART. No clock (oscillator nor external clock) is required for a data bus transaction. Each

bus cycle is asynchronous using CS# A - D, IOR# and IOW# or CS#, R/W#, A4 and A3 inputs. All four UART channels share the same data bus for host operations. A typical data bus interconnection for Intel and Motorola Modes is shown in Figure 6.

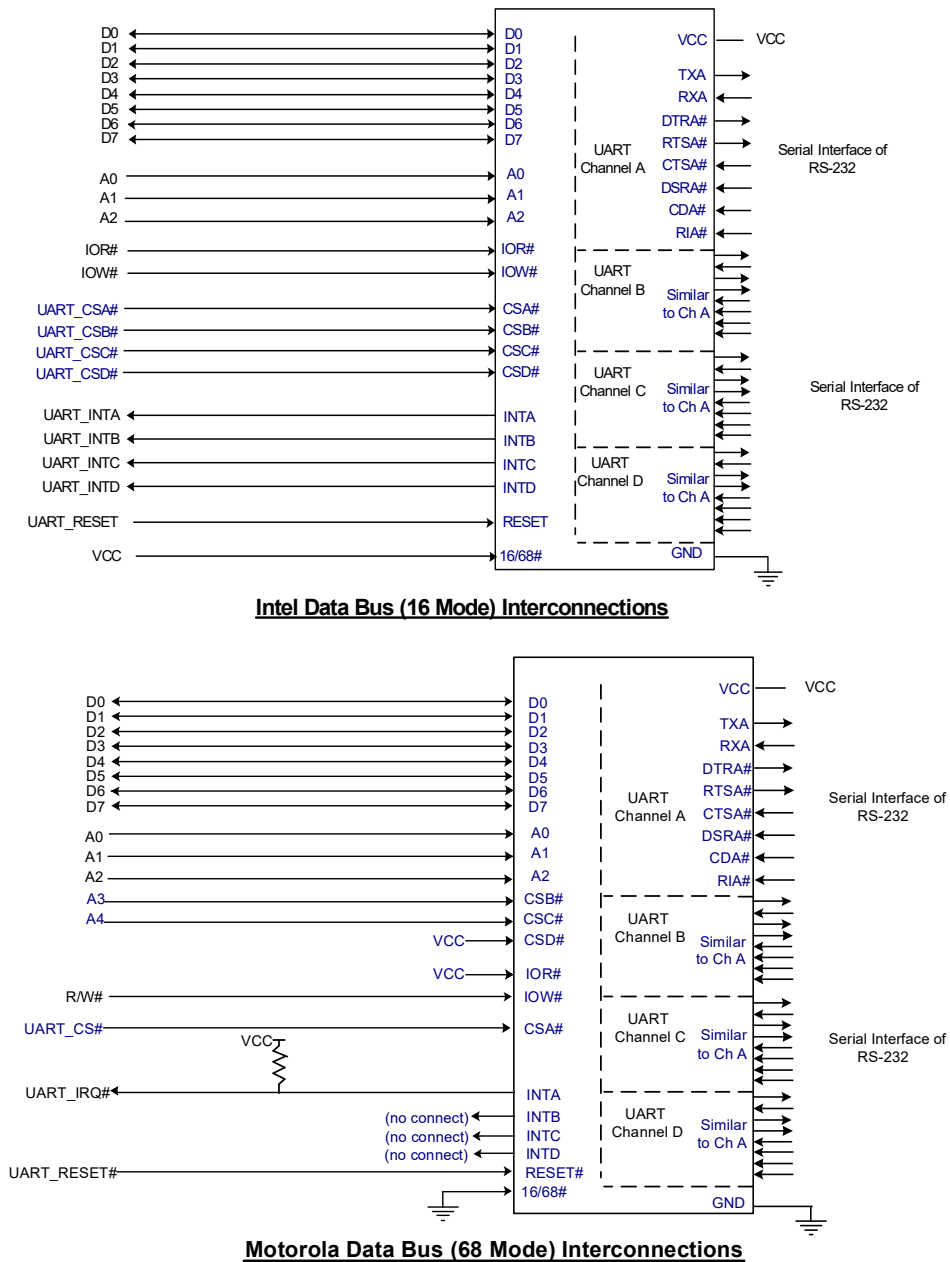

Figure 6: ST16C554D Typical Intel and Motorola Data Bus Interconnections

3.2 Device Reset

The RESET input resets the internal registers and the serial interface outputs in all channels to their default state (see [Table 16](#)). An active high pulse of longer than a 40ns duration will be required to activate the reset function in the device. Following a power-on reset or an external reset, the ST16C554 is software compatible with previous generation of UARTs, the 16C454 and 16C554.

3.3 Channel Selection

The UART provides the user with the capability to bi-directionally transfer information between an external CPU and an external serial communication device. During Intel Bus Mode (16/68# pin is connected to VCC), a logic 0 on chip select pins CSA#, CSB#, CSC#, or CSD# allows the user to select UART channel A, B, C, or D to configure, send transmit data and unload receive data to and from the UART. Selecting all four UARTs can be useful during power up initialization to write to the same internal registers, but do not attempt to read from all four UARTs simultaneously. Individual channel select functions are shown in [Table 2](#).

Table 2: Channel A - D Select in 16 Mode

CSA#	CSB#	CSC#	CSD#	Function
1	1	1	1	UART de-selected
0	1	1	1	Channel A selected
1	0	1	1	Channel B selected
1	1	0	1	Channel C selected
1	1	1	0	Channel D selected
0	0	0	0	Channels A - D selected

During Motorola Bus Mode (16/68# pin is connected to GND), the package interface pins are configured for connection with Motorola, and other popular microprocessor bus types. In this mode, the ST16C554 decodes two additional addresses, A3 and A4, to select one of the four UART ports. The A3 and A4 address decode function is used only in the Motorola Bus Mode. See [Table 3](#).

Table 3: Channel A - D Select in 68 Mode

CS#	A4	A3	Function
1	X	X	UART de-selected
0	0	0	Channel A selected
0	0	1	Channel B selected
0	1	0	Channel C selected
0	1	1	Channel D selected

3.4 Internal Registers of Channels A - D

Each UART channel in the ST16C554 has a set of enhanced registers for controlling, monitoring and data loading and unloading. The configuration register set is compatible to those already available in the standard single 16C550. These registers function as data holding registers (THR / RHR), interrupt status and control registers (ISR / IER), a FIFO control register (FCR), receive line status and control registers (LSR / LCR), modem status and control registers (MSR / MCR), programmable data rate (clock) divisor registers (DLL / DLM), and a user accessible scratchpad register (SPR). All the register functions are discussed in full detail later in [UART Internal Registers](#).

3.5 INT Outputs for Channels A - D

The interrupt outputs change according to the operating mode and enhanced features setup. [Table 4](#) and [Table 5](#) summarize the operating behavior for the transmitter and receiver. Also see [Figure 20](#) through [Figure 25](#).

Table 4: INT Pin Operation for Channel A - D Transmitters

INT Pin	FCR Bit-0 = 0 (FIFO Disabled)	FCR Bit-0 = 1 (FIFO Enabled)	
		FCR Bit-3 = 0 (DMA Mode Disabled)	FCR Bit-3 = 1 (DMA Mode Enabled)
LOW	A byte in THR	FIFO above trigger level	FIFO above trigger level
HIGH	THR empty	FIFO below trigger level or FIFO empty	FIFO below trigger level or FIFO empty

Table 5: INT Pin Operation for Channel A - D Receivers

INT Pin	FCR Bit-0 = 0 (FIFO Disabled)	FCR Bit-0 = 1 (FIFO Enabled)	
		FCR Bit-3 = 0 (DMA Mode Disabled)	FCR Bit-3 = 1 (DMA Mode Enabled)
LOW	No data	FIFO below trigger level	FIFO below trigger level
HIGH	1 byte	FIFO above trigger level	FIFO above trigger level

3.6 DMA Mode

The device does not support direct memory access. The DMA Mode (a legacy term) in this document does not mean “direct memory access”, but refers to data block transfer operation. The DMA mode affects the state of the RXRDY# A - D and TXRDY# A - D output pins. The transmit and receive FIFO trigger levels provide additional flexibility to the user for block mode operation. The LSR bits 5-6 provide an indication when the transmitter is empty or has empty locations for more data. The user can optionally operate the transmit and receive FIFO in the DMA mode

(FCR bit-3 = 1). When the transmit and receive FIFOs are enabled and the DMA mode is disabled (FCR bit-3 = 0), the ST16C554 is placed in Single-Character Mode for data transmit or receive operation. When DMA Mode is enabled (FCR bit-3 = 1), the user takes advantage of block mode operation by loading or unloading the FIFO in a block sequence determined by the programmed trigger level. The following table shows their behavior. Also see [Figure 20](#) through [Figure 25](#).

Table 6: TXRDY# and RXRDY# Outputs in FIFO and DMA Mode for Channels A - D

Pins		FCR Bit-0 = 0 (FIFO Disabled)	FCR Bit-0 = 1 (FIFO Enabled)	
			FCR Bit-3 = 0 (DMA Mode Disabled)	FCR Bit-3 = 1 (DMA Mode Enabled)
RXRDY#	LOW	1 byte	At least 1 byte in FIFO	HIGH to LOW transition when FIFO reaches the trigger level, or timeout occurs. LOW to HIGH transition when FIFO empties.
	HIGH	No data	FIFO empty	
TXRDY#	LOW	THR empty	FIFO empty	FIFO has at least 1 empty location
	HIGH	Byte in THR	At least 1 byte in FIFO	FIFO is full

3.7 Crystal Oscillator or External Clock Input

The ST16C554 includes an on-chip oscillator (XTAL1 and XTAL2) to produce a clock for both UART sections in the device. The CPU data bus does not require this clock for bus operation. The crystal oscillator provides a system clock to the Baud Rate Generators (BRG) section found in each of the UARTs. XTAL1 is the input to the oscillator or external clock buffer input with XTAL2 pin being the output. For programming details, see [Programmable Baud Rate Generator](#).

The on-chip oscillator is designed to use an industry standard microprocessor crystal (parallel resonant, fundamental frequency with 10 - 22pF capacitance load, ESR of 20 - 120Ω and 100ppm frequency tolerance) connected externally between the XTAL1 and XTAL2 pins. Typical oscillator connections are shown in [Figure 7](#).

Alternatively, an external clock can be connected to the XTAL1 pin to clock the internal baud rate generator for standard or custom rates. For further reading on oscillator circuit please see [Application Note DAN108](#) on MaxLinear’s web site.

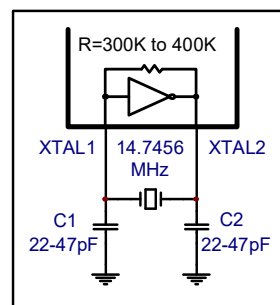
**Figure 7: Typical Crystal Connections**

3.8 Programmable Baud Rate Generator

Each UART has its own Baud Rate Generator (BRG) for the transmitter and receiver. The BRG further divides this clock by a programmable divisor between 1 and $(2^{16} - 1)$ to obtain a 16X sampling rate clock of the serial data rate. The sampling rate clock is used by the transmitter for data bit shifting and the receiver for data sampling. The BRG

divisor is unknown (DLL = 0xXX and DLM = 0xXX) and should be initialized after power up. Programming the Baud Rate Generator Registers DLL and DLM provide the capability for selecting the operating data rate. [Table 7](#) shows the standard data rates available with a 14.7456MHz crystal or external clock.

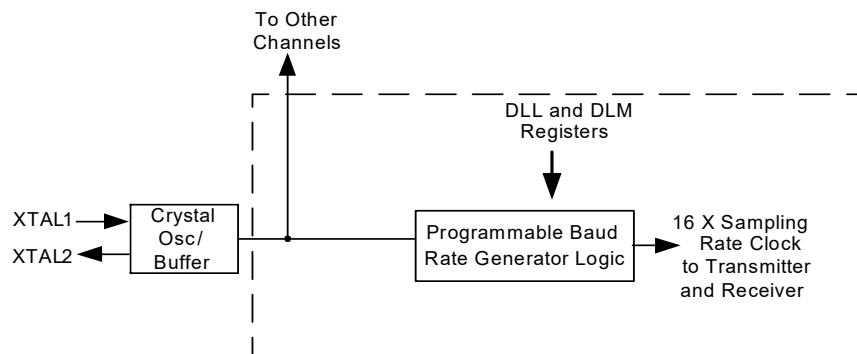

Figure 8: Baud Rate Generator

Table 7: Typical Data Rates with a 14.7456MHz Crystal or External Clock

Output Data Rate MCR Bit-7=1	Output Data Rate MCR Bit-7=0 (Default)	Divisor for 16x Clock (Decimal)	Divisor for 16x Clock (HEX)	DLM Program Value (HEX)	DLL Program Value (HEX)	Data Rate Error (%)
100	400	2304	900	09	00	0
600	2400	384	180	01	80	0
1200	4800	192	C0	00	C0	0
2400	9600	96	60	00	60	0
4800	19.2k	48	30	00	30	0
9600	38.4k	24	18	00	18	0
19.2k	76.8k	12	0C	00	0C	0
38.4k	153.6k	6	06	00	06	0
57.6k	230.4k	4	04	00	04	0
115.2k	460.8k	2	02	00	02	0
230.4k	921.6k	1	01	00	01	0

3.9 Transmitter

The transmitter section comprises of an 8-bit Transmit Shift Register (TSR) and 16 bytes of FIFO which includes a byte-wide Transmit Holding Register (THR). TSR shifts out every data bit with the 16X internal sampling clock. A bit time is 16X clock periods. The transmitter sends the start-bit followed by the number of data bits, inserts the proper parity-bit if enabled, and adds the stop-bit(s). The status of the FIFO and TSR are reported in the Line Status Register (LSR bit-5 and bit-6).

3.9.1 Transmit Holding Register (THR) - Write Only

The transmit holding register is an 8-bit register providing a data interface to the host processor. The host writes a transmit data byte to the THR to be converted into a serial data stream including start-bit, data bits, parity-bit and stop-bit(s). The least-significant-bit (bit-0) becomes the first data bit to go out. The THR is the input register to the transmit FIFO of 16 bytes when FIFO operation is enabled by FCR bit-0. Every time a write operation is made to the THR, the FIFO data pointer is automatically bumped to the next sequential data location.

3.9.2 Transmitter Operation in Non-FIFO Mode

The host loads transmit data to THR one character at a time. The THR empty flag (LSR bit-5) is set when the data byte is transferred to TSR. The THR flag can generate a transmit empty interrupt (ISR bit-1) when it is enabled by IER bit-1. The TSR flag (LSR bit-6) is set when TSR becomes completely empty.

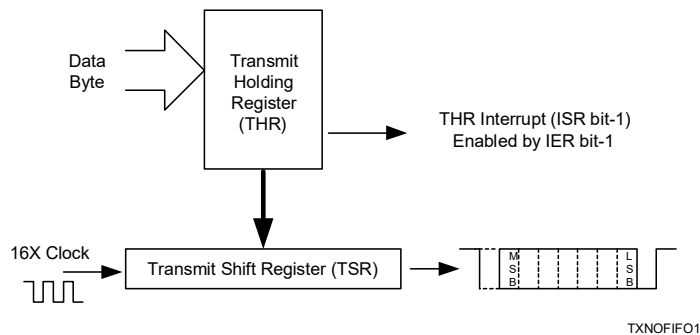

Figure 9: Transmitter Operation in Non-FIFO Mode

3.9.3 Transmitter Operation in FIFO Mode

The host may fill the transmit FIFO with up to 16 bytes of transmit data. The THR empty flag (LSR bit-5) is set whenever the FIFO is empty. The THR empty flag can generate a transmit empty interrupt (ISR bit-1) when the FIFO becomes empty. The transmit empty interrupt is enabled by IER bit-1. The TSR flag (LSR bit-6) is set when TSR and the FIFO becomes empty.

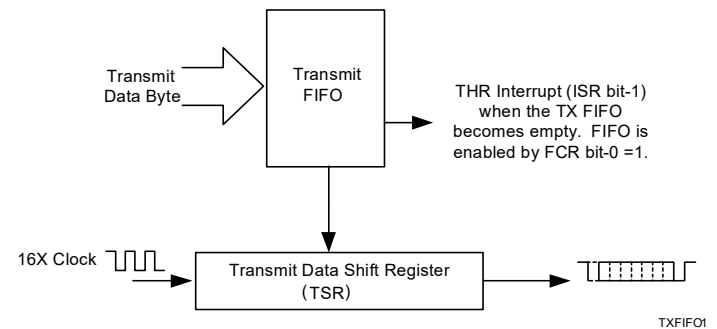

Figure 10: Transmitter Operation in FIFO Mode

3.10 Receiver

The receiver section contains an 8-bit Receive Shift Register (RSR) and 16 bytes of FIFO which includes a byte-wide Receive Holding Register (RHR). The RSR uses the 16X clock for timing. It verifies and validates every bit on the incoming character in the middle of each data bit. On the falling edge of a start or false start bit, an internal receiver counter starts counting at the 16X clock rate. After 8 clocks, the start bit period should be at the center of the start bit. At this time the start bit is sampled, and if it is still LOW it is validated. Evaluating the start bit in this manner prevents the receiver from assembling a false character. The rest of the data bits and stop bits are sampled and validated in this same manner to prevent false framing. If there were any error(s), they are reported in the LSR register bits 2 - 4. Upon unloading the receive data byte from RHR, the receive FIFO pointer is bumped and the error tags are immediately updated to reflect the status of the data byte in the RHR register. RHR can generate a receive data ready interrupt upon receiving a character or delay, until it reaches the FIFO trigger level. Furthermore, data delivery to the host is guaranteed by a receive data ready time-out interrupt when data is not received for 4 word lengths as defined by LCR[1:0] plus 12 bits time. This is equivalent to 3.7 - 4.6 character times. The RHR interrupt is enabled by IER bit-0. See [Figure 11](#) and [Figure 12](#).

3.10.1 Receive Holding Register (RHR) - Read Only

The Receive Holding Register is an 8-bit register that holds a receive data byte from the Receive Shift Register. It provides the receive data interface to the host processor. The RHR register is part of the receive FIFO of 16 bytes by 11-bit wide; the 3 extra bits are for the 3 error tags to be reported in LSR register. When the FIFO is enabled by

FCR bit-0, the RHR contains the first data character received by the FIFO. After the RHR is read, the next character byte is loaded into the RHR and the errors associated with the current data byte are immediately updated in the LSR bits 2 - 4.

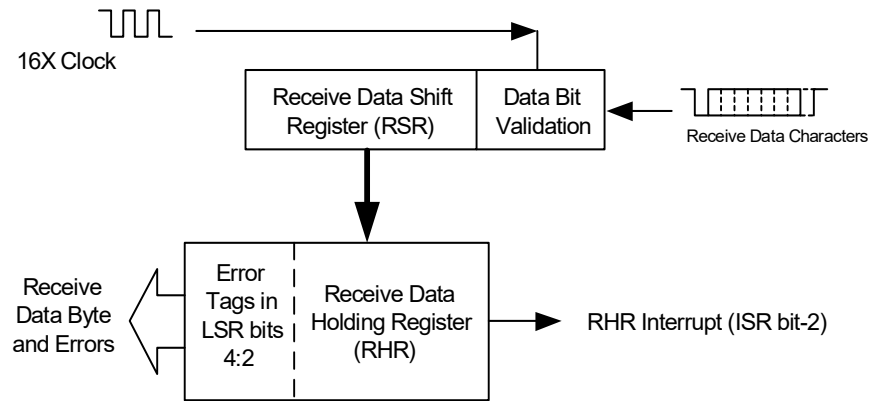

RXFIFO1

Figure 11: Receiver Operation in Non-FIFO Mode

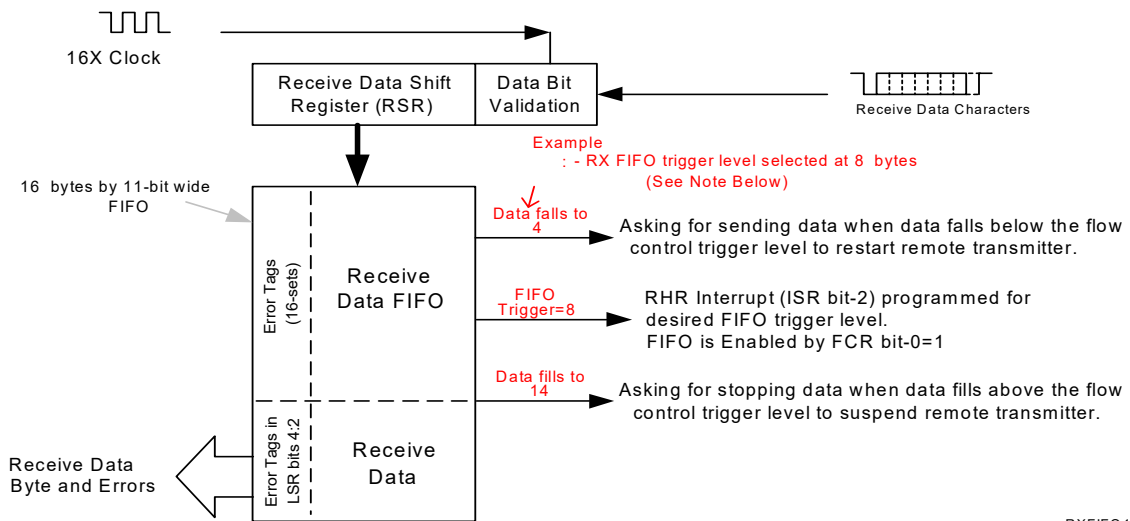

RXFIFO1

Figure 12: Receiver Operation in FIFO Mode

3.11 Internal Loopback

The ST16C554 UART provides an internal loopback capability for system diagnostic purposes. The internal loopback mode is enabled by setting MCR register bit-4 to a logic 1. All regular UART functions operate normally.

Figure 13 shows how the modem port signals are re-configured. Transmit data from the Transmit Shift Register output is internally routed to the Receive Shift Register input, allowing the system to receive the same data that it

was sending. The TX pin is held HIGH or at mark condition while RTS# and DTR# are de-asserted, and CTS#, DSR# CD# and RI# inputs are ignored.

Important: The RX input must be held HIGH during the loopback test, else upon exiting the loopback test the UART may detect and report a false “break” signal.

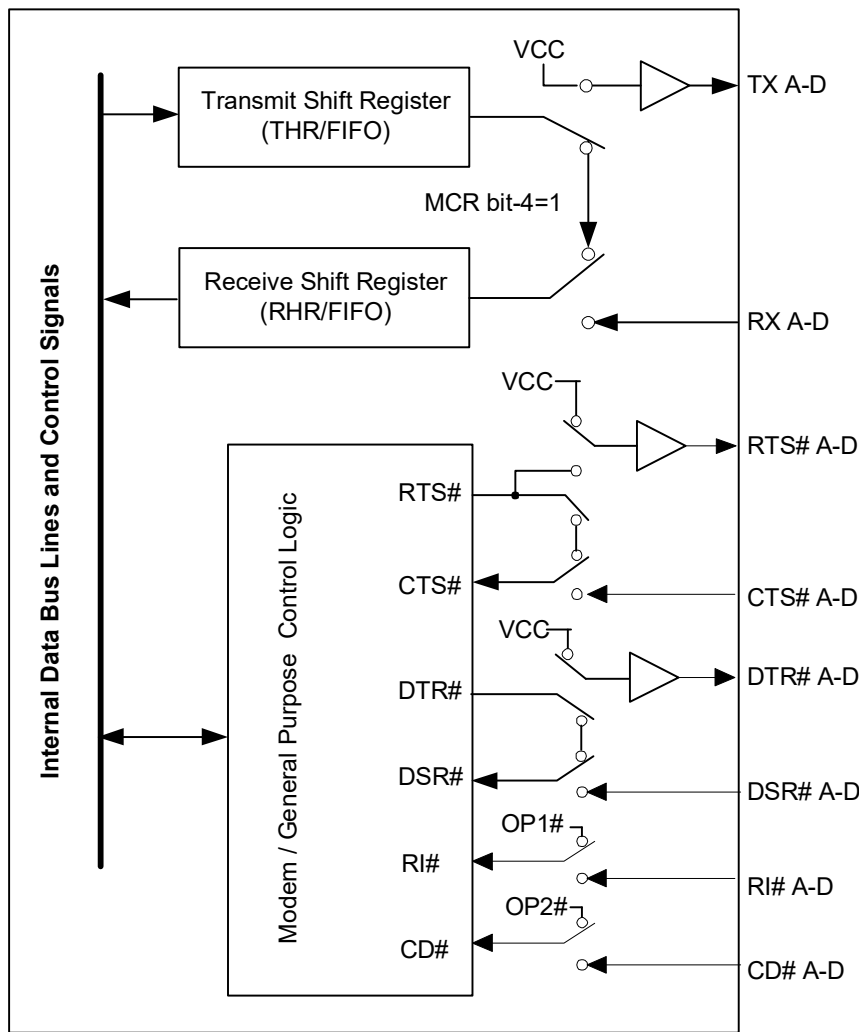

Figure 13: Internal Loopback in Channels A and B

4.0 UART Internal Registers

Each UART channel in the ST16C554 has its own set of configuration registers selected by address lines A0, A1, and A2 with a specific channel selected (see [Table 2](#) and [Table 3](#)). The complete register set is shown in [Table 8](#) and [Table 9](#).

Table 8: Internal Registers of UART Channels A and B

A2, A1, A0 Addresses	Register	Read and Write	Comments
16C550 Compatible Registers			
0 0 0	RHR - Receive Holding Register	Read-only	LCR[7] = 0
	THR - Transmit Holding Register	Write-only	
0 0 0	DLL - Divisor LSB	Read and write	LCR[7] = 1
0 0 1	DLM - Divisor MSB	Read and write	
0 0 1	IER - Interrupt Enable Register	Read and write	LCR[7] = 0
0 1 0	ISR - Interrupt Status Register	Read-only	
	FCR - FIFO Control Register	Write-only	
0 1 1	LCR - Line Control Register	Read and write	LCR[7] = 0
1 0 0	MCR - Modem Control Register	Read and write	
1 0 1	LSR - Line Status Register	Read-only	
1 1 0	MSR - Modem Status Register	Read-only	
1 1 1	SPR - Scratch Pad Register	Read and write	

Table 9: Internal Register Descriptions

Address A2 - A0	Register Name	Read / Write	Bit-7	Bit-6	Bit-5	Bit-4	Bit-3	Bit-2	Bit-1	Bit-0	Comment
16C550 Compatible Registers											
0 0 0	RHR	RD	Bit-7	Bit-6	Bit-5	Bit-4	Bit-3	Bit-2	Bit-1	Bit-0	LCR[7] = 0
0 0 0	THR	WR	Bit-7	Bit-6	Bit-5	Bit-4	Bit-3	Bit-2	Bit-1	Bit-0	
0 0 1	IER	RD / WR	0	0	0	0	Modem Stat. Int. Enable	RX Line Stat. Int. Enable	TX Empty Int. Enable	RX Data Int. Enable	
0 1 0	ISR	RD	FIFOs Enabled	FIFOs Enabled	0	0	INT Source Bit-3	INT Source Bit-2	INT Source Bit-1	INT Source Bit-0	
0 1 0	FCR	WR	RX FIFO Trigger	RX FIFO Trigger	0	0	DMA Mode Enable	TX FIFO Reset	RX FIFO Reset	FIFOs Enable	LCR[7] = 0
0 1 1	LCR	RD / WR	Divisor Enable	Set TX Break	Set Parity	Even Parity	Parity Enable	Stop Bits	Word Length Bit-1	Word Length Bit-0	
1 0 0	MCR	RD / WR	0	0	0	Internal Loopback Enable	INT Output Enable (OP2#)	Rsvd (OP1#)	RTS# Output Control	DTR# Output Control	
1 0 1	LSR	RD / WR	RX FIFO Global Error	THR, TSR Empty	THR Empty	RX Break	RX Framing Error	RX Parity Error	RX Overrun Error	RX Data Ready	LCR[7] = 0
1 1 0	MSR	RD / WR	CD# Input	RI# Input	DSR# Input	CTS# Input	Delta CD#	Delta RI#	Delta DSR#	Delta CTS#	
1 1 1	SPR	RD / WR	Bit-7	Bit-6	Bit-5	Bit-4	Bit-3	Bit-2	Bit-1	Bit-0	
Baud Rate Generator Divisor											
0 0 0	DLL	RD / WR	Bit-7	Bit-6	Bit-5	Bit-4	Bit-3	Bit-2	Bit-1	Bit-0	LCR[7]=1
0 0 1	DLM	RD / WR	Bit-7	Bit-6	Bit-5	Bit-4	Bit-3	Bit-2	Bit-1	Bit-0	LCR≠0xBF

5.0 Internal Register Descriptions

5.1 Receive Holding Register (RHR) - Read-Only

See [Receiver](#) on page 10.

5.2 Transmit Holding Register (THR) - Write-Only

See [Transmitter](#) on page 10.

5.3 Interrupt Enable Register (IER) - Read and Write

The Interrupt Enable Register (IER) masks the interrupts from receive data ready, transmit empty, line status, and modem status registers. These interrupts are reported in the Interrupt Status Register (ISR).

5.3.1 IER Versus Receive FIFO Interrupt Mode Operation

When the receive FIFO (FCR bit-0 = 1) and receive interrupts (IER bit-0 = 1) are enabled, the RHR interrupts (see ISR bits 2 and 3) status will reflect the following:

- A.** The receive data available interrupts are issued to the host when the FIFO has reached the programmed trigger level. It will be cleared when the FIFO drops below the programmed trigger level.
- B.** FIFO level will be reflected in the ISR register when the FIFO trigger level is reached. Both the ISR register status bit and the interrupt will be cleared when the FIFO drops below the trigger level.
- C.** The receive data ready bit (LSR bit-0) is set as soon as a character is transferred from the shift register to the receive FIFO. It is reset when the FIFO is empty.

5.3.2 IER Versus Receive and Transmit FIFO Polled Mode Operation

When FCR bit-0 equals a logic 1 for FIFO enable, resetting IER bits 0 - 3 enables the FIFO polled mode of operation. Since the receiver and transmitter have separate bits in the

LSR, either or both can be used in the polled mode by selecting the respective transmit or receive control bit(s).

- A.** LSR bit-0 indicates there is data in RHR or RX FIFO.
- B.** LSR bit-1 indicates an overrun error has occurred and that data in the FIFO may not be valid.
- C.** LSR bits 2 - 4 provide the type of receive data errors encountered for the data byte in RHR, if any.
- D.** LSR bit-5 indicates THR is empty.
- E.** LSR bit-6 indicates both the transmit FIFO and TSR are empty.
- F.** LSR bit-7 indicates a data error in at least one character in the RX FIFO.

IER[0]: RHR Interrupt Enable

The receive data ready interrupt will be issued when RHR has a data character in the non-FIFO mode or when the receive FIFO has reached the programmed trigger level in the FIFO mode.

- Logic 0 = Disable the receive data ready interrupt (default).
- Logic 1 = Enable the receiver data ready interrupt.

IER[1]: THR Interrupt Enable

This bit enables the Transmit Ready Interrupt which is issued whenever the THR becomes empty. If the THR is empty when this bit is enabled, an interrupt will be generated.

- Logic 0 = Disable Transmit Ready interrupt (default).
- Logic 1 = Enable Transmit Ready interrupt.

IER[2]: Receive Line Status Interrupt Enable

If any of the LSR register bits 1, 2, 3, or 4 is a logic 1, it will generate an interrupt to inform the host controller about the error status of the current data byte in FIFO. LSR bit-1 generates an interrupt immediately when an overrun occurs. LSR bits 2 - 4 generate an interrupt when the character in the RHR has an error.

- Logic 0 = Disable the receiver line status interrupt (default).
- Logic 1 = Enable the receiver line status interrupt.

IER[3]: Modem Status Interrupt Enable

- Logic 0 = Disable the modem status register interrupt (default).
- Logic 1 = Enable the modem status register interrupt.

IER[7:4]: Reserved (Default 0)

5.4 Interrupt Status Register (ISR)

The UART provides multiple levels of prioritized interrupts to minimize external software interaction. The Interrupt Status Register (ISR) provides the user with six interrupt status bits. Performing a read cycle on the ISR will give the user the current highest pending interrupt level to be serviced, others are queued up to be serviced next. No other interrupts are acknowledged until the pending interrupt is serviced. The Interrupt Source Table, [Table 10](#), shows the data values (bit 0 - 3) for the interrupt priority levels and the interrupt sources associated with each of these interrupt levels.

5.4.1 Interrupt Generation

- LSR is by any of the LSR bits 1, 2, 3, and 4.
- RXRDY is by RX trigger level.
- RXRDY time-out is by a 4-character plus 12 bits delay timer.
- TXRDY is by THR empty (non-FIFO mode) or TX FIFO empty (FIFO mode).
- MSR is by any of the MSR bits 0, 1, 2, and 3.

Table 10: Interrupt Source and Priority Level

Priority Level	ISR Register Status Bits				Source of Interrupt
	Bit-3	Bit-2	Bit-1	Bit-0	
1	0	1	1	0	LSR (Receiver Line Status Register)
2	1	1	0	0	RXRDY (Receive Data Time-out)
3	0	1	0	0	RXRDY (Received Data Ready)
4	0	0	1	0	TXRDY (Transmit Empty)
5	0	0	0	0	MSR (Modem Status Register)
-	0	0	0	1	None (default)

5.4.2 Interrupt Clearing

- LSR interrupt is cleared by a read to the LSR register.
- RXRDY interrupt is cleared by reading data until the FIFO falls below the trigger level.
- RXRDY time-out interrupt is cleared by reading RHR.
- TXRDY interrupt is cleared by a read to the ISR register or by writing to THR.
- MSR interrupt is cleared by a read to the MSR register.

ISR[0]: Interrupt Status

- Logic 0 = An interrupt is pending and the ISR contents may be used as a pointer to the appropriate interrupt service routine.
- Logic 1 = No interrupt pending (default condition).

ISR[3:1]: Interrupt Status

These bits indicate the source for a pending interrupt at interrupt priority levels (see Interrupt Source [Table 10](#)).

ISR[5:4]: Reserved (Default 0)**ISR[7:6]: FIFO Enable Status**

These bits are set to a logic 0 when the FIFOs are disabled. They are set to a logic 1 when the FIFOs are enabled.

5.5 FIFO Control Register (FCR) - Write-Only

This register is used to enable the FIFOs, clear the FIFOs, set the receive FIFO trigger levels, and select the DMA mode. The DMA and FIFO modes are defined as follows:

FCR[0]: TX and RX FIFO Enable

- Logic 0 = Disable the transmit and receive FIFO (default).
- Logic 1 = Enable the transmit and receive FIFOs. This bit must be set to logic 1 when other FCR bits are written or they will not be programmed.

FCR[1]: RX FIFO Reset

This bit is only active when FCR bit-0 is a '1'.

- Logic 0 = No receive FIFO reset (default).
- Logic 1 = Reset the receive FIFO pointers and FIFO level counter logic (the receive shift register is not cleared or altered). This bit will return to a logic 0 after resetting the FIFO.

FCR[2]: TX FIFO Reset

This bit is only active when FCR bit-0 is a '1'.

- Logic 0 = No transmit FIFO reset (default).
- Logic 1 = Reset the transmit FIFO pointers and FIFO level counter logic (the transmit shift register is not cleared or altered). This bit will return to a logic 0 after resetting the FIFO.

FCR[3]: DMA Mode Select

Controls the behavior of the TXRDY# and RXRDY# pins. See DMA operation section for details.

- Logic 0 = Normal Operation (default).
- Logic 1 = DMA Mode.

FCR[5:4]: Reserved (Default 0)

FCR[7:6]: Receive FIFO Trigger Select

(logic 0 = default, RX trigger level = 1)

These 2 bits are used to set the trigger level for the receive FIFO. The UART will issue a receive interrupt when the number of the characters in the FIFO crosses the trigger level. [Table 11](#) shows the complete selections.

Table 11: Receive FIFO Trigger Level Selection

FCR Bit-7	FCR Bit-6	Receive Trigger Level
0	0	1
0	1	4
1	0	8
1	1	14

5.6 Line Control Register (LCR) - Read and Write

The Line Control Register is used to specify the asynchronous data communication format. The word or character length, the number of stop bits, and the parity are selected by writing the appropriate bits in this register.

LCR[1:0]: TX and RX Word Length Select

These two bits specify the word length to be transmitted or received.

Table 12: TX and RX Word Length

LCR Bit-1	LCR Bit-0	Word Length
0	0	5 (default)
0	1	6
1	0	7
1	1	8

LCR[2]: TX and RX Stop-bit Length Select

The length of stop bit is specified by this bit in conjunction with the programmed word length.

Table 13: TX and RX Stop-Bit Length

LCR Bit-2	Word Length	Stop Bit Length (Bit Time)
0	5,6,7,8	1 (default)
1	5	1-1/2
1	6,7,8	2

LCR[3]: TX and RX Parity Select

Parity or no parity can be selected via this bit. The parity bit is a simple way used in communications for a data integrity check. See [Table 14](#) for parity selection summary below.

- Logic 0 = No parity.
- Logic 1 = A parity bit is generated during the transmission while the receiver checks for parity error of the data character received.

LCR[4]: TX and RX Parity Select

If the parity bit is enabled with LCR bit-3 set to a logic 1, LCR bit-4 selects the even or odd parity format.

- Logic 0 = ODD Parity is generated by forcing an odd number of logic 1's in the transmitted character. The receiver must be programmed to check the same format (default).
- Logic 1 = EVEN Parity is generated by forcing an even number of logic 1's in the transmitted character. The receiver must be programmed to check the same format.

LCR[5]: TX and RX Parity Select

If the parity bit is enabled, LCR bit-5 selects the forced parity format.

- LCR bit-5 = logic 0, parity is not forced (default).
- LCR bit-5 = logic 1 and LCR bit-4 = logic 0, parity bit is forced to HIGH for the transmit and receive data.
- LCR bit-5 = logic 1 and LCR bit-4 = logic 1, parity bit is forced to LOW for the transmit and receive data.

Table 14: Parity Selection

LCR Bit-5	LCR Bit-4	LCR Bit-3	Parity Selection
X	X	0	No parity
0	0	1	Odd parity
0	1	1	Even parity
1	0	1	Force parity to mark, HIGH
1	1	1	Forced parity to space, LOW

LCR[6]: Transmit Break Enable

When enabled, the Break Control Bit causes a break condition to be transmitted (the TX output is forced to a "space", logic 0 state). This condition remains, until disabled by setting LCR bit-6 to a logic 0.

- Logic 0 = No TX break condition (default).
- Logic 1 = Forces the transmitter output (TX) to a "space", logic 0, for alerting the remote receiver of a line break condition.

LCR[7]: Baud Rate Divisors Enable

Baud rate generator divisor (DLL / DLM) enable.

- Logic 0 = Data registers are selected (default).
- Logic 1 = Divisor latch registers are selected.

5.7 Modem Control Register (MCR) or General Purpose Outputs Control - Read and Write

The MCR register is used for controlling the serial modem interface signals or general purpose inputs and outputs.

MCR[0]: DTR# Output

The DTR# pin is a modem control output. If the modem interface is not used, this output may be used as a general purpose output.

- Logic 0 = Force DTR# output HIGH (default).
- Logic 1 = Force DTR# output LOW.

MCR[1]: RTS# Output

The RTS# pin is a modem control output. If the modem interface is not used, this output may be used as a general purpose output.

- Logic 0 = Force RTS# output HIGH (default).
- Logic 1 = Force RTS# output LOW.

MCR[2]: Reserved

OP1# is not available as an output pin on the ST16C554. However, it is available for use during Internal Loopback Mode. In the Loopback Mode, this bit is used to write the state of the modem RI# interface signal.

MCR[3]: INT Output Enable

Enable or disable INT outputs to become active or in three-state. This function is associated with the INTSEL input, see below table for details. This bit is also used to control the OP2# signal during internal loopback mode. INTSEL pin must be LOW during 68 mode.

- Logic 0 = INT (A - D) outputs disabled (three state) in the 16 mode (default). During internal loopback mode, OP2# is HIGH.
- Logic 1 = INT (A - D) outputs enabled (active) in the 16 mode. During internal loopback mode, OP2# is LOW.

Table 15: INT Output Modes

INTSEL Pin	MCR Bit-3	INT A - D Outputs in 16 Mode
0	0	Three-State
0	1	Active
1	X	Active

MCR[4]: Internal Loopback Enable

- Logic 0 = Disable loopback mode (default).
- Logic 1 = Enable local loopback mode, see loopback section and [Table 13](#).

MCR[7:5]: Reserved (Default 0)

5.8 Line Status Register (LSR) - Read and Write

This register is writeable, but it is not recommended. The LSR provides the status of data transfers between the UART and the host. If IER bit-2 is enabled, LSR bit-1 will generate an interrupt immediately and LSR bits 2-4 will generate an interrupt when a character with an error is in the RHR.

LSR[0]: Receive Data Ready Indicator

- Logic 0 = No data in receive holding register or FIFO (default).
- Logic 1 = Data has been received and can be read from the receive holding register or RX FIFO.

LSR[1]: Receiver Overrun Flag

- Logic 0 = No overrun error (default).
- Logic 1 = Overrun error. A data overrun error condition occurred in the Receive Shift Register. This happens when additional data arrives while the FIFO is full. In this case, the previous data in the Receive Shift Register is overwritten. Note that under this condition the data byte in the Receive Shift Register is not transferred into the FIFO, therefore the data in the FIFO is not corrupted by the error.

LSR[2]: Receive Data Parity Error Tag

- Logic 0 = No parity error (default).
- Logic 1 = Parity error. The receive character in RHR does not have correct parity information and is suspect. This error is associated with the character available for reading in RHR.

LSR[3]: Receive Data Framing Error Tag

- Logic 0 = No framing error (default).
- Logic 1 = Framing error. The receive character did not have a valid stop bit(s). This error is associated with the character available for reading in RHR.

LSR[4]: Receive Break Tag

- Logic 0 = No break condition (default).
- Logic 1 = The receiver received a break signal (RX was LOW for at least a one character frame time). In the FIFO mode, only one break character is loaded into the FIFO. The break indication remains until the RX input returns to the idle condition, "mark" or HIGH.

LSR[5]: Transmit Holding Register Empty Flag

This bit is the Transmit Holding Register empty indicator. The THR bit is set to a logic 1 when the last data byte is transferred from the Transmit Holding Register to the Transmit Shift Register. The bit is reset to logic 0 concurrently with the data loading to the Transmit Holding Register by the host. In the FIFO mode, this bit is set when the transmit FIFO is empty. It is cleared when the transmit FIFO contains at least 1 byte.

LSR[6]: THR and TSR Empty Flag

This bit is set to a logic 1 whenever the transmitter goes idle. It is set to logic 0 whenever either the THR or TSR contains a data character. In the FIFO mode, this bit is set to a logic 1 whenever the transmit FIFO and Transmit Shift Register are both empty.

LSR[7]: Receive FIFO Data Error Flag

- Logic 0 = No FIFO error (default).
- Logic 1 = A global indicator for the sum of all error bits in the RX FIFO. At least one parity error, framing error, or break indication is in the FIFO data. This bit clears when there is no more error(s) in any of the bytes in the RX FIFO.

5.9 Modem Status Register (MSR) - Read and Write

This register is writeable, but it is not recommended. The MSR provides the current state of the modem interface input signals. The lower four bits of this register are used to indicate the changed information. These bits are set to a logic 1 whenever a signal from the modem changes state. These bits may be used for general purpose inputs when they are not used with modem signals.

MSR[0]: Delta CTS# Input Flag

- Logic 0 = No change on CTS# input (default).
- Logic 1 = The CTS# input has changed state since the last time it was monitored. A modem status interrupt will be generated if the MSR interrupt is enabled (IER bit-3).

MSR[1]: Delta DSR# Input Flag

- Logic 0 = No change on DSR# input (default).
- Logic 1 = The DSR# input has changed state since the last time it was monitored. A modem status interrupt will be generated if the MSR interrupt is enabled (IER bit-3).

MSR[2]: Delta RI# Input Flag

- Logic 0 = No change on RI# input (default).
- Logic 1 = The RI# input has changed from LOW to HIGH, ending of the ringing signal. A modem status interrupt will be generated if the MSR interrupt is enabled (IER bit-3).

MSR[3]: Delta CD# Input Flag

- Logic 0 = No change on CD# input (default).
- Logic 1 = Indicates that the CD# input has changed state since the last time it was monitored. A modem status interrupt will be generated if the MSR interrupt is enabled (IER bit-3).

MSR[4]: CTS Input Status

A HIGH on the CTS# pin will stop the UART transmitter as soon as the current character has finished transmission. A LOW will resume data transmission. Normally the MSR bit-4 is the compliment of the CTS# input. However in the loopback mode, this bit is equivalent to the RTS# bit in the MCR register. The CTS# input may be used as a general purpose input when the modem interface is not used.

MSR[5]: DSR Input Status

Normally this bit is the complement of the DSR# input. In the loopback mode, this bit is equivalent to the DTR# bit in the MCR register. The DSR# input may be used as a general purpose input when the modem interface is not used.

MSR[6]: RI Input Status

Normally this bit is the complement of the RI# input. In the loopback mode, this bit is equivalent to bit-2 in the MCR register. The RI# input may be used as a general purpose input when the modem interface is not used.

MSR[7]: CD Input Status

Normally this bit is the complement of the CD# input. In the loopback mode, this bit is equivalent to bit-3 in the MCR register. The CD# input may be used as a general purpose input when the modem interface is not used.

5.10 Scratch Pad Register (SPR) - Read and Write

This is a 8-bit general purpose register for the user to store temporary data.

5.11 Baud Rate Generator Registers (DLL and DLM) - Read and Write

These registers make-up the value of the baud rate divisor. The concatenation of the contents of DLM and DLL gives the 16-bit divisor value. [See Programmable Baud Rate Generator on page 9.](#)

Table 16: UART Reset Conditions for Channels A - D

Item	Reset State
Registers	
DLM, DLL	DLM and DLL are unknown upon power up. They do not reset when the Reset Pin is asserted.
RHR	Bits 7 - 0 = 0xXX
THR	Bits 7 - 0 = 0xXX
IER	Bits 7 - 0 = 0x00
FCR	Bits 7 - 0 = 0x00
ISR	Bits 7 - 0 = 0x01
LCR	Bits 7 - 0 = 0x00
MCR	Bits 7 - 0 = 0x00
LSR	Bits 7 - 0 = 0x60
MSR	Bits 3 - 0 = Logic 0 Bits 7 - 4 = Logic levels of the inputs inverted
SPR	Bits 7 - 0 = 0xFF
I/O Signals	
TX	HIGH
IRTX	LOW
RTS#	HIGH
DTR#	HIGH
RXRDY#	HIGH
TXRDY#	LOW
INT (16 Mode)	LOW
IRQ# (68 Mode)	HIGH (INTSEL = LOW)

6.0 Specifications

6.1 Absolute Maximum Ratings

Table 17: Absolute Maximum Ratings

Parameter	Minimum	Maximum	Units
Power supply range		7.0	V
Voltage at any pin	GND – 0.3	$V_{CC} + 0.3V$	V
Operating temperature	See Ordering Information .		
Storage temperature	–65	150	°C
Package Dissipation	500		mW

Table 18: Typical Package Thermal Resistance Data⁽¹⁾

Package	θ_{JA}	θ_{JC}	Units
LQFP64	50	11	°C/W
PLCC68	46	17	°C/W

1. Margin of error: ±15%

6.2 Electrical Characteristics

6.2.1 DC Electrical Characteristics

Unless otherwise noted: $T_A = 0^\circ\text{C} - 70^\circ\text{C}$ (–40°C to +85°C for industrial grade package), $V_{CC} = 2.97\text{V}$ to 5.5V .

Table 19: Electrical Characteristics

Symbol	Parameter	Conditions	Limits (3.3V)		Limits (5.0V)		Units
			Minimum	Maximum	Minimum	Maximum	
V_{ILCK}	Clock input low level		–0.3	0.6	–0.3	0.6	V
V_{IHCK}	Clock input high level		2.4	V_{CC}	3.0	V_{CC}	V
V_{IL}	Input low voltage		–0.3	0.8	–0.3	0.8	V
V_{IH}	Input high voltage		2.0	V_{CC}	2.2	V_{CC}	V
V_{OL}	Output low voltage	$I_{OL} = 5\text{mA}$				0.4	V
		$I_{OL} = 4\text{mA}$		0.4			V
V_{OH}	Output high voltage	$I_{OH} = -5\text{mA}$			2.4		V
		$I_{OH} = -1\text{mA}$	2.0				V
I_{IL}	Input low leakage current			±10		±10	µA
I_{IH}	Input high leakage current			±10		±10	µA
C_{IN}	Input pin capacitance			5		5	pF
I_{CC}	Power supply current			3		6	mA

6.2.2 AC Electrical Characteristics

$T_A = 0^\circ\text{C} - 70^\circ\text{C}$ (-40°C to $+85^\circ\text{C}$ for industrial grade package), $V_{CC} = 2.97\text{V}$ to 5.5V , 70pF load where applicable.

Table 20: AC Electrical Characteristics

Symbol	Parameter	Limits 3.3V $\pm 10\%$		Limits 5.0V $\pm 10\%$		Units
		Minimum	Maximum	Minimum	Maximum	
CLK	External clock low / high time	63		21		ns
OSC	UART crystal or external clock frequency		8		24	MHz
T_{AS}	Address setup time (16 Mode)	5		0		ns
T_{AH}	Address hold time (16 Mode)	5		5		ns
T_{CS}	Chip select width (16 Mode)	80		50		ns
T_{RD}	IOR# strobe width (16 Mode)	80		50		ns
T_{DY}	Read cycle delay (16 Mode)	40		30		ns
T_{RDV}	Data access time (16 Mode)		40		25	ns
T_{DD}	Data disable time (16 Mode)		25		15	ns
T_{WR}	IOW# strobe width (16 Mode)	35		25		ns
T_{DY}	Write cycle delay (16 Mode)	40		30		ns
T_{DS}	Data setup time (16 Mode)	20		15		ns
T_{DH}	Data hold time (16 Mode)	5		5		ns
T_{ADS}	Address setup (68 Mode)	10		10		ns
T_{ADH}	Address hold (68 Mode)	15		15		ns
T_{RWS}	R/W# setup to CS# (68 Mode)	10		10		ns
T_{RDA}	Data access time (68 mode)		40		25	ns
T_{RDH}	Data disable time (68 mode)		25		15	ns
T_{WDS}	Write data setup (68 mode)	20		15		ns
T_{WDH}	Write data hold (68 Mode)	10		10		ns
T_{RWH}	CS# de-asserted to R/W# de-asserted (68 Mode)	10		10		ns
T_{CSL}	CS# strobe width (68 Mode)	80		50		ns
T_{CSD}	CS# cycle delay (68 Mode)	40		30		ns
T_{WDO}	Delay from IOW# to output		50		40	ns
T_{MOD}	Delay to set interrupt from MODEM input		40		35	ns
T_{RSI}	Delay to reset interrupt from IOR#		40		35	ns
T_{SSI}	Delay from stop to set interrupt		1		1	Bclk
T_{RRI}	Delay from IOR# to reset interrupt		45		40	ns
T_{SI}	Delay from start to interrupt		45		40	ns
T_{INT}	Delay from initial INT reset to transmit start	8	24	8	24	Bclk
T_{WRI}	Delay from IOW# to reset interrupt		45		40	ns
T_{SSR}	Delay from stop to set RXRDY#		1		1	Bclk
T_{RR}	Delay from IOR# to reset RXRDY#		45		40	ns
T_{WT}	Delay from IOW# to set TXRDY#		45		40	ns

Table 20: AC Electrical Characteristics

Symbol	Parameter	Limits 3.3V ±10%		Limits 5.0V ±10%		Units
		Minimum	Maximum	Minimum	Maximum	
T _{SRT}	Delay from center of start to reset TXRDY#		8		8	Bclk
T _{RST}	Reset pulse width	40		40		ns
N	Baud rate divisor	1	2 ¹⁶ -1	1	2 ¹⁶ -1	-
Bclk	Baud clock	16X of data rate				Hz

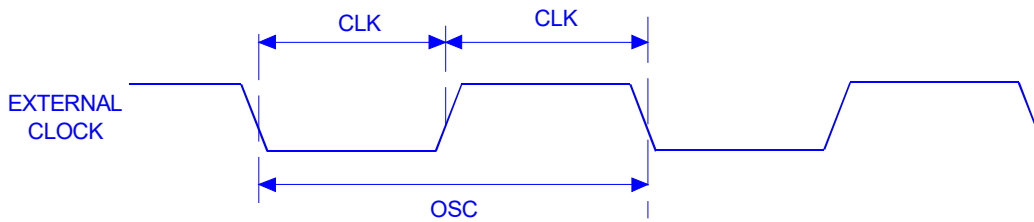

Figure 14: Clock Timing

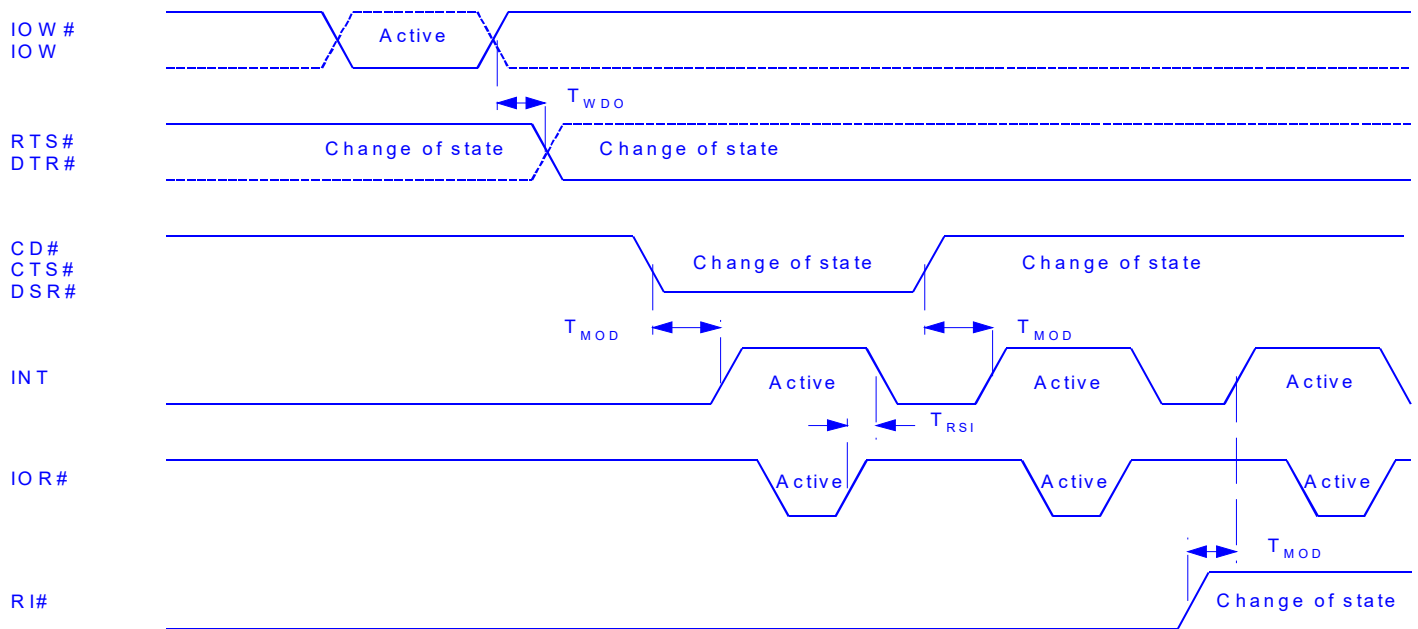
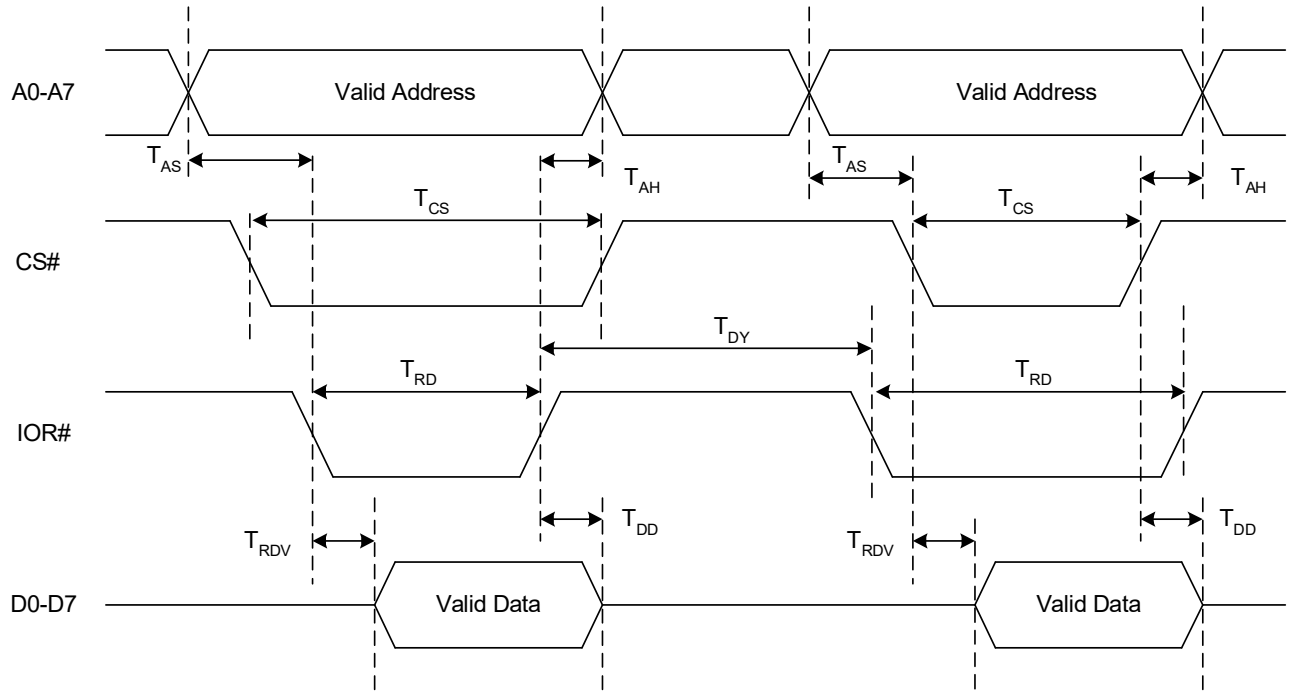
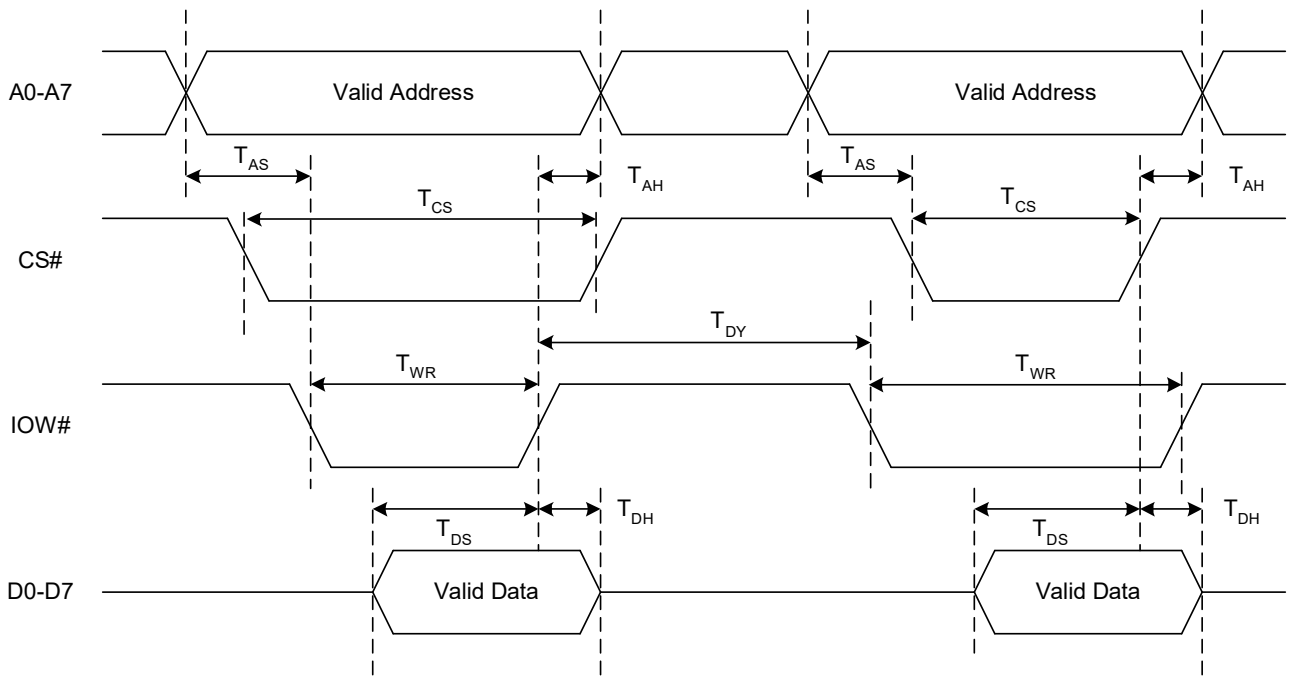

Figure 15: Modem Input and Output Timing for Channels A - D



RDTm

Figure 16: 16 Mode (Intel) Data Bus Read Timing for Channels A - D



16Write

Figure 17: 16 Mode (Intel) Data Bus Write Timing for Channels A - D

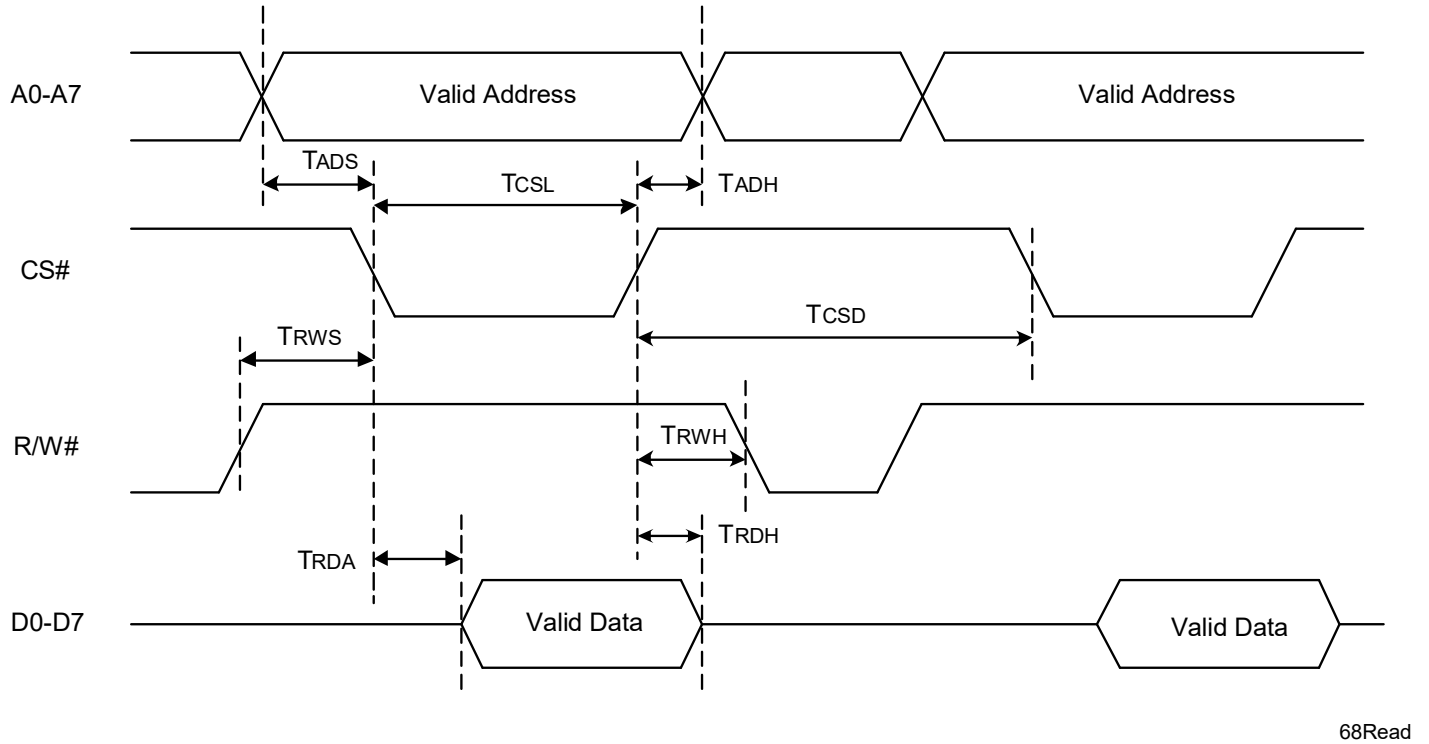

Figure 18: 68 Mode (Motorola) Data Bus Read Timing for Channels A - D

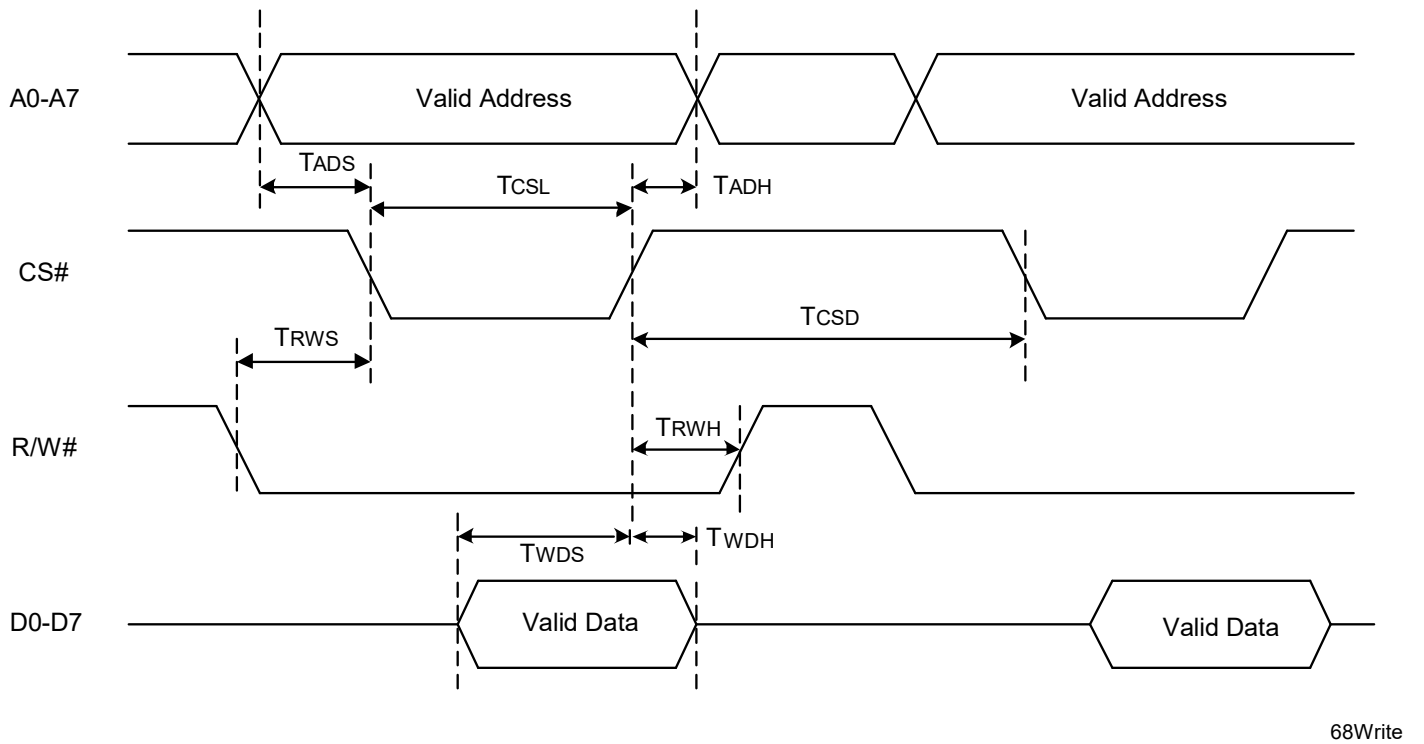
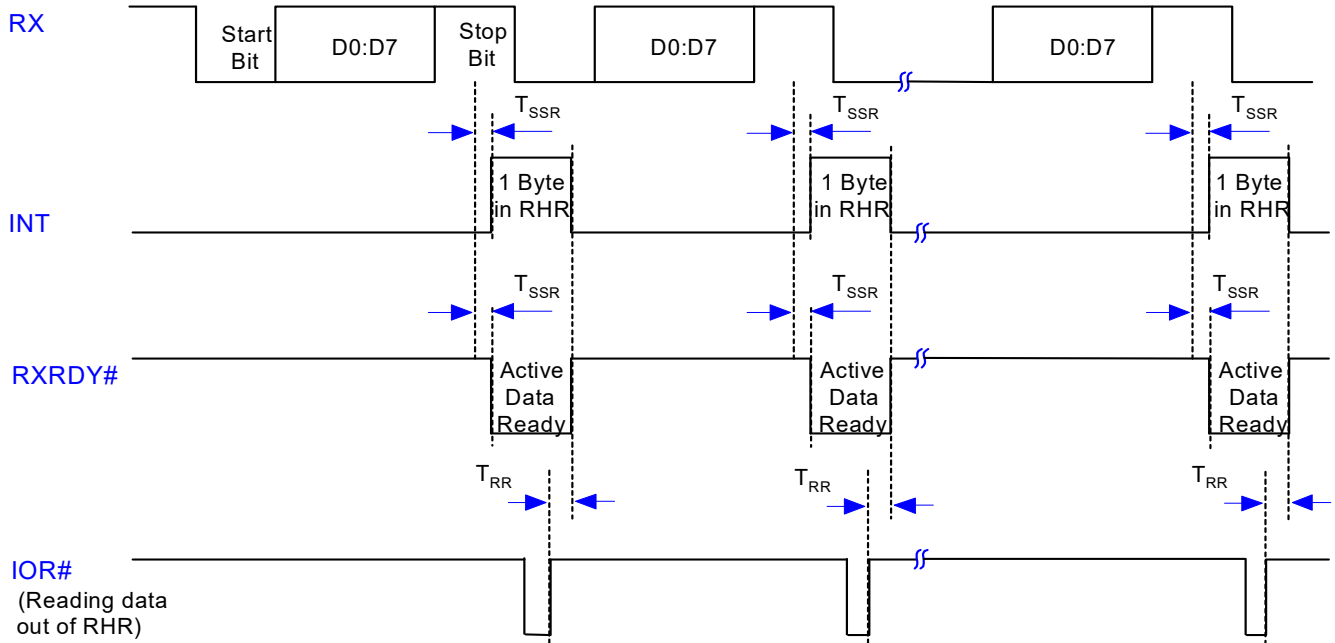
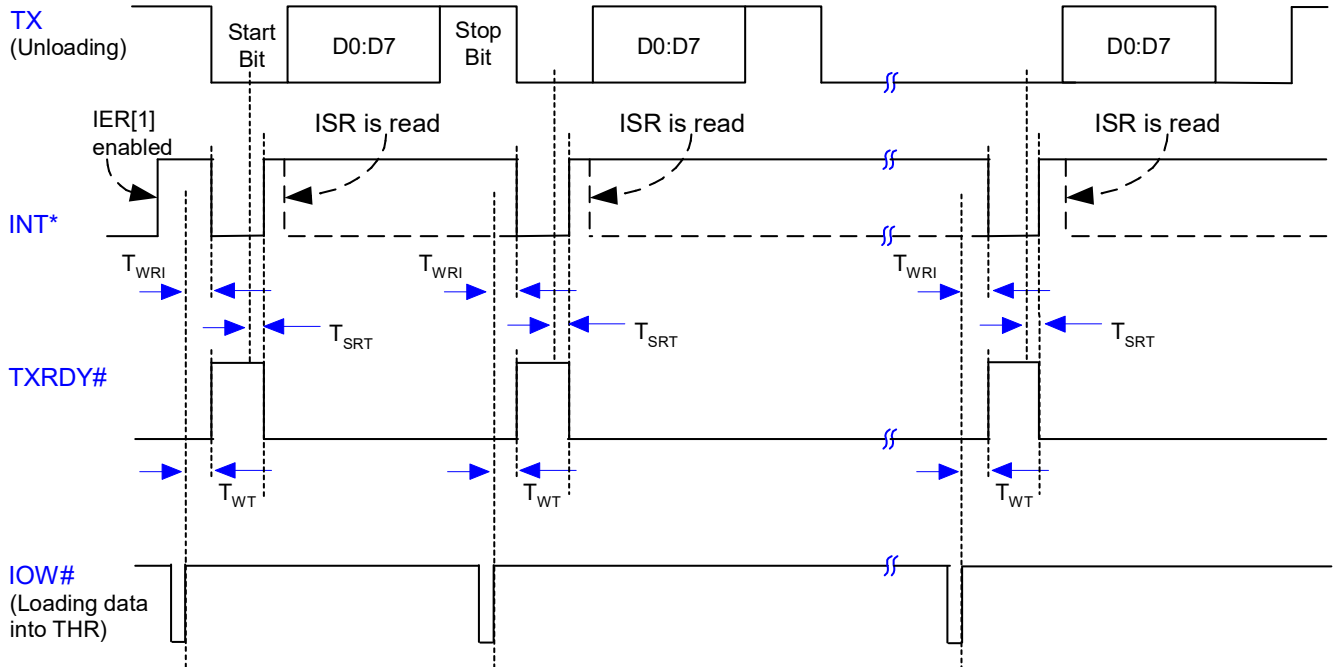

Figure 19: 68 Mode (Motorola) Data Bus Write Timing for Channels A - D



RXNFM

Figure 20: Receive Ready and Interrupt Timing (Non-FIFO Mode) for Channels A - D



*INT is cleared when the ISR is read or when data is loaded into the THR.

TXNonFIFO

Figure 21: Transmit Ready and Interrupt Timing (Non-FIFO Mode) for Channels A - D

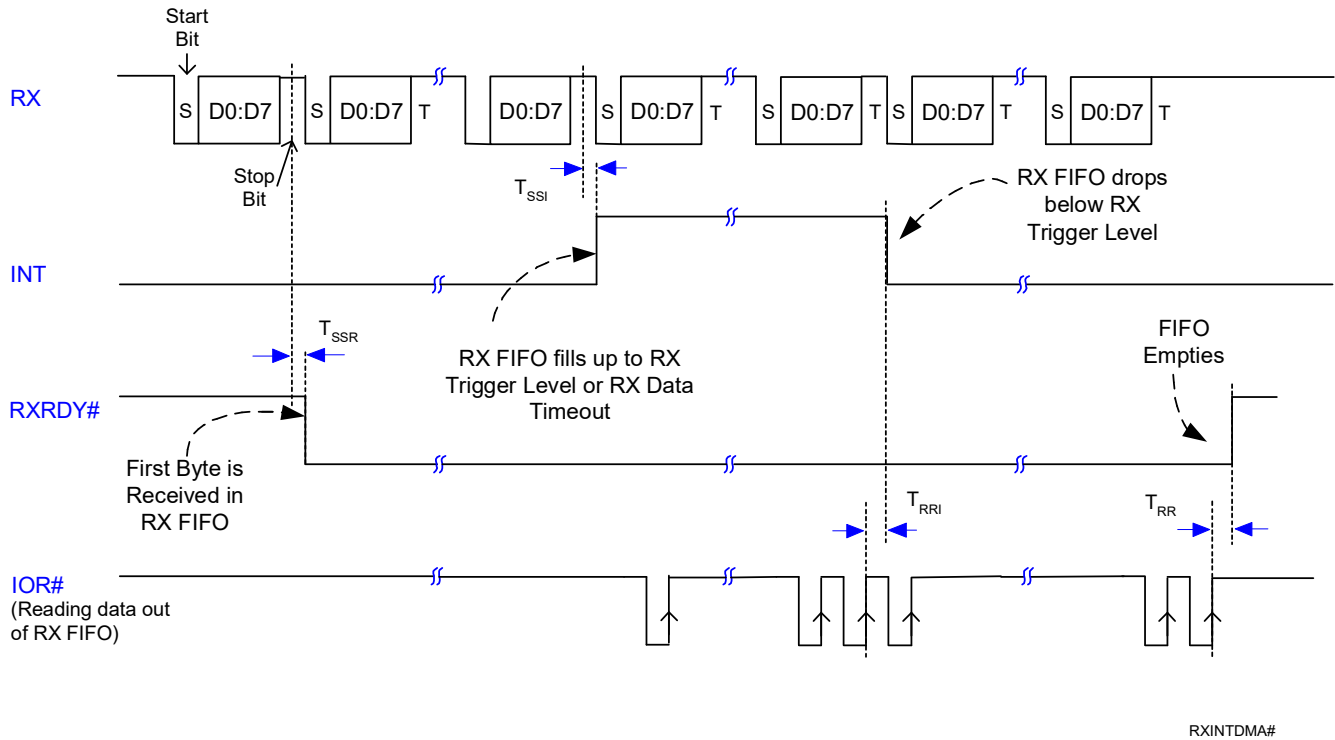

Figure 22: Receive Ready and Interrupt Timing (FIFO Mode, DMA Disabled) for Channels A - D

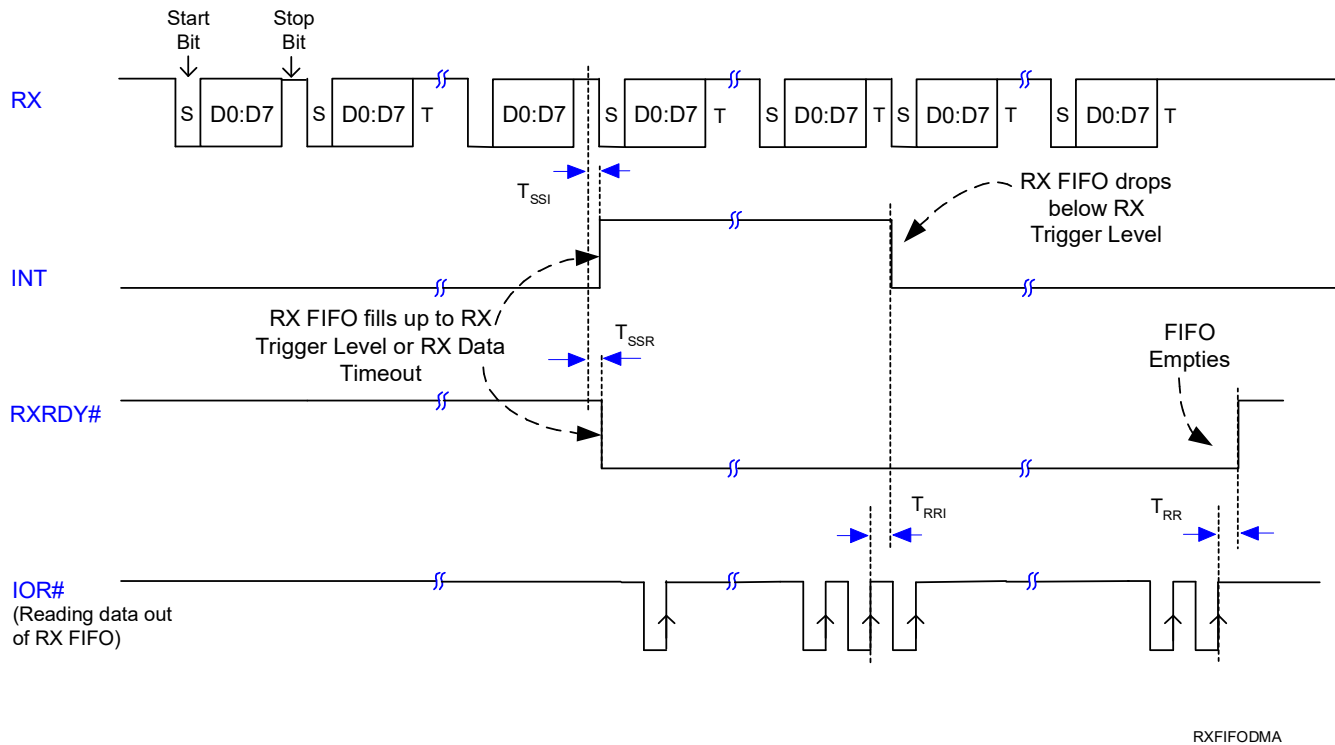
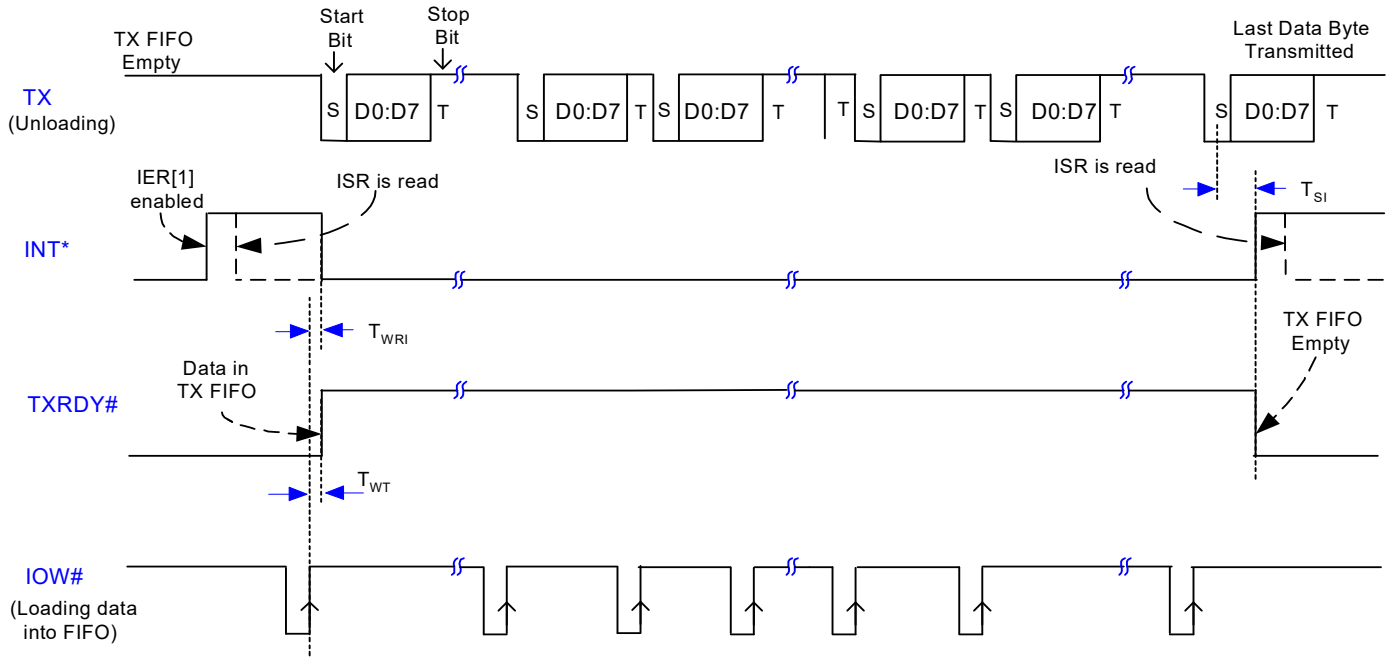
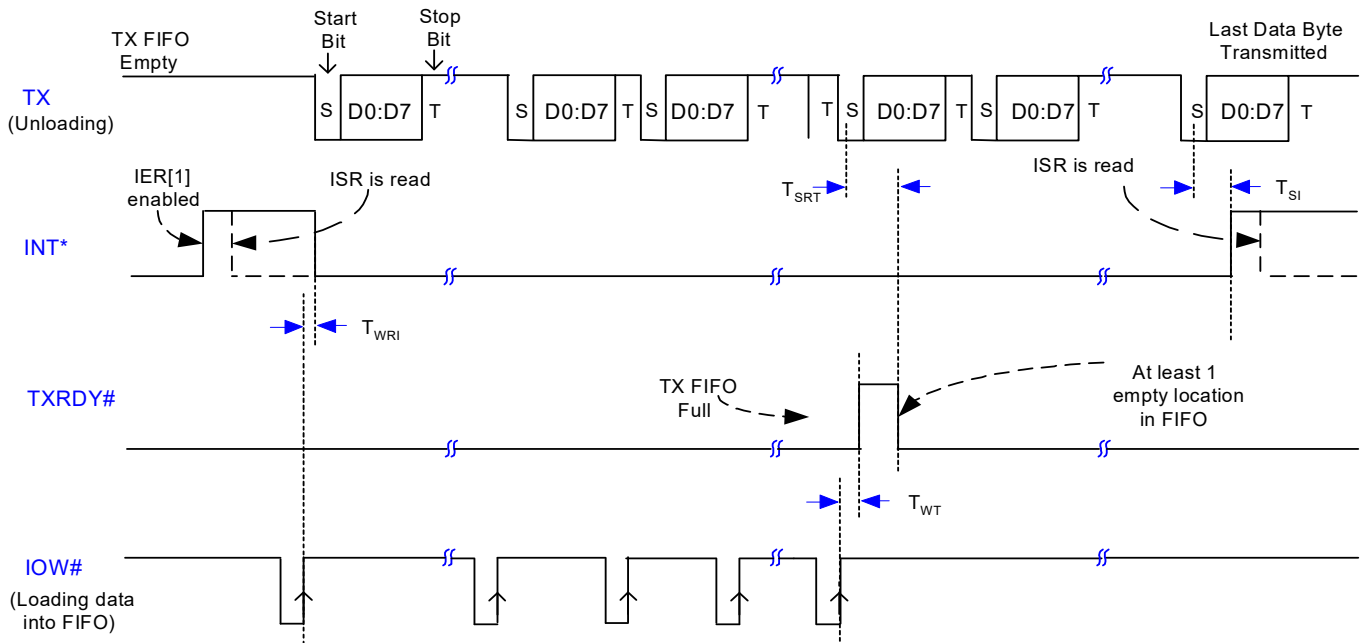

Figure 23: Receive Ready and Interrupt Timing (FIFO Mode, DMA Enabled) for Channels A - D



*INT is cleared when the ISR is read or when at least 1 byte is written to the TX FIFO.

Figure 24: Transmit Ready and Interrupt Timing (FIFO Mode, DMA Disabled) for Channels A - D



*INT is cleared when the ISR is read or when at least 1 byte is written to the TX FIFO.

Figure 25: Transmit Ready and Interrupt Timing (FIFO Mode, DMA Enabled) for Channels A - D

7.0 Mechanical Dimensions

7.1 LQFP64

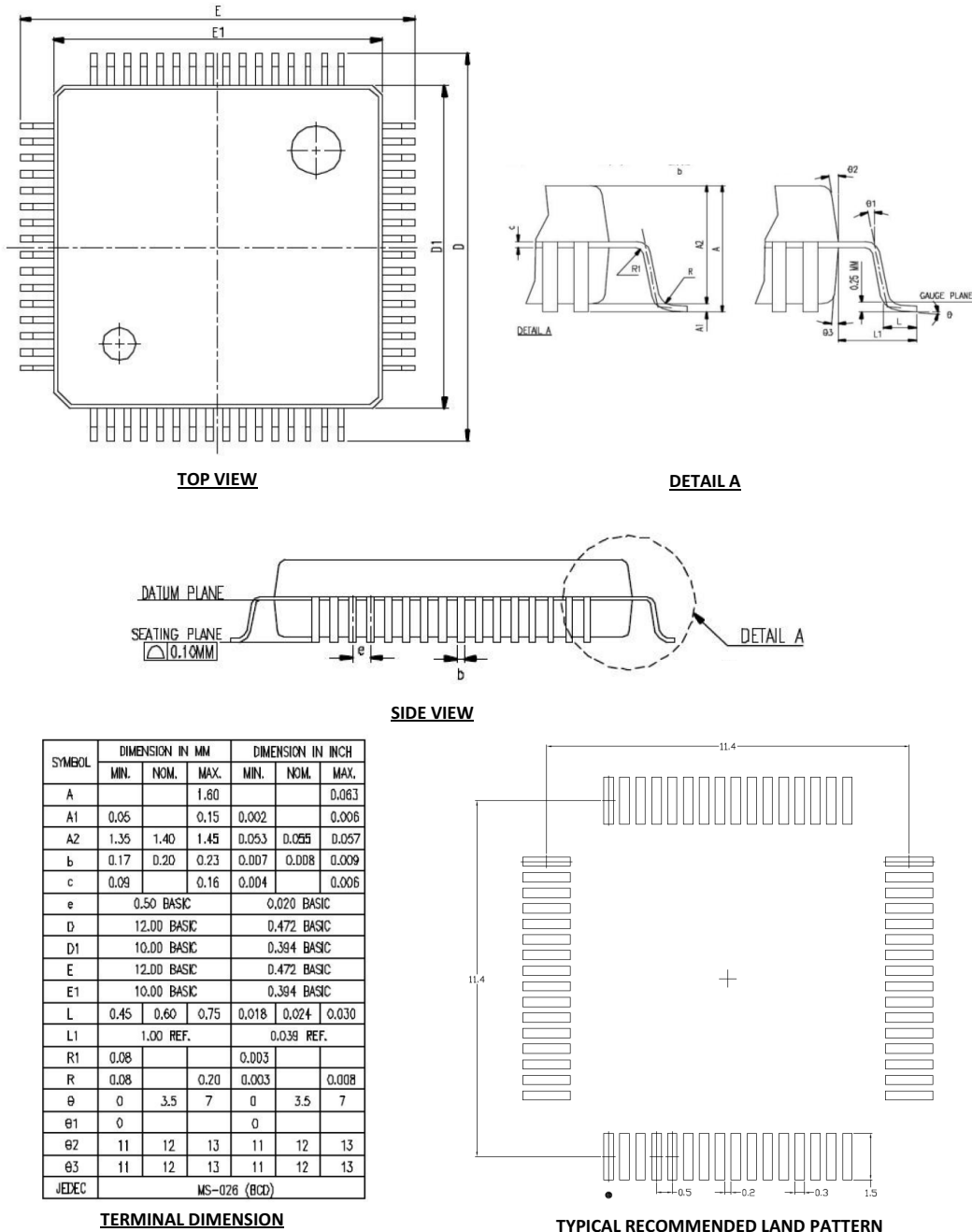

1. Control dimensions are in Millimeters
2. Dimensions and tolerance per Jecdec MS-026

Drawing No. : POD - 00000092

Revision: A

Figure 26: Mechanical Dimension, LQFP64 (10 x 10 x 1.4mm Low-Profile Quad Flat Pack)

7.2 PLCC68

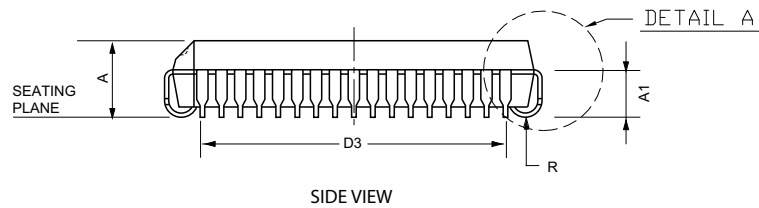
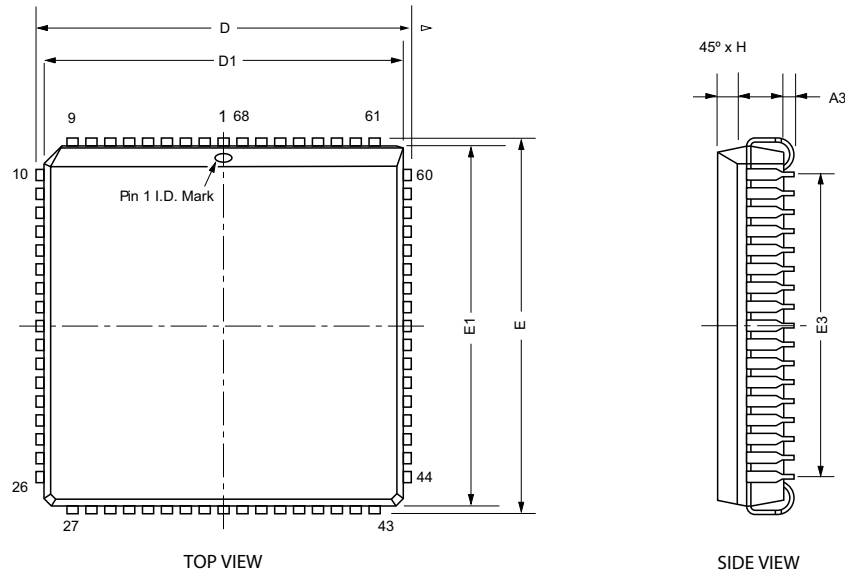

DIM SYMBOL	MIN	NOM	MAX
A	4.19	4.37	4.57
A1	2.29	2.67	3.05
A3	0.51	—	—
D	25.02	25.15	25.27
D1	24.13	24.23	24.33
D3	20.32 REF		
E	25.02	25.15	25.27
E1	24.13	24.23	24.33
E3	20.32 REF		
H	1.07	—	1.42
e	1.27 BSC		
R	0.64	—	1.14
W	0.66	0.74	0.81
W1	0.33	0.43	0.53
N	68		

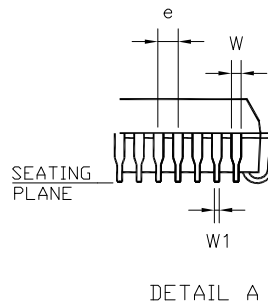

TERMINAL DETAILS

- ALL DIMENSIONS ARE IN MILLIMETERS, ANGLES ARE IN DEGREES.
- DIMENSIONS AND TOLERANCE PER JEDEC MS-0018.

Drawing No.: POD-000000 145

Revision: A

Figure 27: Mechanical Dimensions, PLCC68 (Plastic Leaded Chip Carrier)

8.0 Ordering Information

Table 21: Ordering Information⁽¹⁾

Ordering Part Number	Operating Temperature Range	Package	Packaging Method	Lead-Free ⁽²⁾
ST16C554				
ST16C554CQ64-F	0°C to 70°C	LQFP64	Tray	Yes
ST16C554D				
ST16C554DCQ64-F	0°C to 70°C	LQFP64	Tray	Yes
ST16C554DIQ64-F	-40°C to +85°C	LQFP64	Tray	Yes
ST16C554DIQ64TR-F	-40°C to +85°C	LQFP64	Reel	Yes
ST16C554DCJ68-F	0°C to 70°C	PLCC68	Tube	Yes
ST16C554DCJ68TR-F	0°C to 70°C	PLCC68	Reel	Yes
ST16C554DIJ68-F	-40°C to +85°C	PLCC68	Tube	Yes
ST16C554DIJ68TR-F	-40°C to +85°C	PLCC68	Reel	Yes
ST68C554				
ST68C554IJ68-F	-40°C to +85°C	PLCC68	Tube	Yes

1. Refer to www.maxlinear.com/ST16C554, www.maxlinear.com/ST16C554D, and www.maxlinear.com/ST68C554 for most up-to-date Ordering Information.

2. Visit www.maxlinear.com for additional information on Environmental Rating.



MaxLinear, Inc.
5966 La Place Court, Suite 100
Carlsbad, CA 92008
760.692.0711 p.
760.444.8598 f.
www.maxlinear.com

The content of this document is furnished for informational use only, is subject to change without notice, and should not be construed as a commitment by MaxLinear, Inc. MaxLinear, Inc. assumes no responsibility or liability for any errors or inaccuracies that may appear in the informational content contained in this guide. Complying with all applicable copyright laws is the responsibility of the user. Without limiting the rights under copyright, no part of this document may be reproduced into, stored in, or introduced into a retrieval system, or transmitted in any form or by any means (electronic, mechanical, photocopying, recording, or otherwise), or for any purpose, without the express written permission of MaxLinear, Inc.

MaxLinear, Inc. does not recommend the use of any of its products in life support applications where the failure or malfunction of the product can reasonably be expected to cause failure of the life support system or to significantly affect its safety or effectiveness. Products are not authorized for use in such applications unless MaxLinear, Inc. receives, in writing, assurances to its satisfaction that: (a) the risk of injury or damage has been minimized; (b) the user assumes all such risks; (c) potential liability of MaxLinear, Inc. is adequately protected under the circumstances.

MaxLinear, Inc. may have patents, patent applications, trademarks, copyrights, or other intellectual property rights covering subject matter in this document. Except as expressly provided in any written license agreement from MaxLinear, Inc., the furnishing of this document does not give you any license to these patents, trademarks, copyrights, or other intellectual property.

MaxLinear, the MaxLinear logo, and any MaxLinear trademarks, MxL, Full-Spectrum Capture, FSC, G.now, AirPHY and the MaxLinear logo are all on the products sold, are all trademarks of MaxLinear, Inc. or one of MaxLinear's subsidiaries in the U.S.A. and other countries. All rights reserved. Other company trademarks and product names appearing herein are the property of their respective owners.

Looking for pricing, stock, or lifecycle information?

Click below to explore more details on WIN SOURCE:

 [View LT3022EMSE#TRPBF on WIN SOURCE](#)

 [Linear Technology](#) Information

Optimize Your Supply Chain with WIN SOURCE Solutions

-  Global Sourcing Solution
-  Obsolete Management
-  Cost Control Management
-  Shortage Management
-  Alternative Solution
-  Excess Inventory Management