



**THE DATASHEET OF
LT3461AES6#TRMPBF**



1.3MHz/3MHz Step-Up DC/DC Converters with Integrated Schottky in ThinSOT

FEATURES

- Integrated Schottky Rectifier
- Fixed Frequency 1.3MHz/3MHz Operation
- High Output Voltage: Up to 38V
- Low V_{CESAT} Switch: 260mV at 250mA
- 12V at 70mA from 5V Input
- 5V at 115mA from 3.3V Input
- Wide Input Range: 2.5V to 16V
- Uses Small Surface Mount Components
- Low Shutdown Current: <1 μ A
- Soft-Start
- Low Profile (1mm) SOT-23 (ThinSOT™) Package

APPLICATIONS

- Digital Cameras
- CCD Bias Supply
- XDSL Power Supply
- TFT-LCD Bias Supply
- Local 5V or 12V Supply
- Medical Diagnostic Equipment
- Battery Backup

DESCRIPTION

The LT[®]3461/LT3461A are general purpose fixed frequency current mode step-up DC/DC converters. Both devices feature an integrated Schottky and a low V_{CESAT} switch allowing a small converter footprint and lower parts cost. The LT3461 switches at 1.3MHz while the LT3461A switches at 3MHz. These high switching frequencies enable the use of tiny, low cost and low height capacitors and inductors. The constant switching frequency results in predictable output noise that is easy to filter, and the inductor based topology ensures an input free from switching noise typically present with charge pump solutions. The high voltage switch in the LT3461/LT3461A is rated at 40V making the device ideal for boost converters up to 38V.

The LT3461/LT3461A are available in a low profile (1mm) SOT-23 package.

LT, LT, LTC, LTM, Linear Technology and the Linear logo are registered trademarks and ThinSOT is a trademark of Linear Technology Corporation.

TYPICAL APPLICATION

5V to 12V, 70mA Step-Up DC/DC Converter

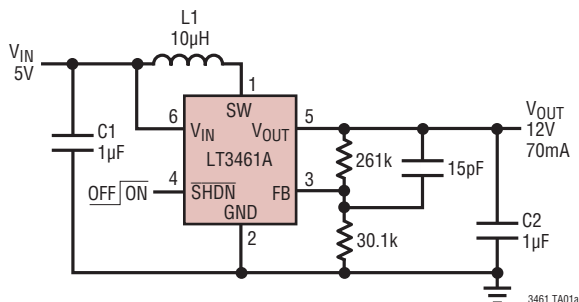

Efficiency

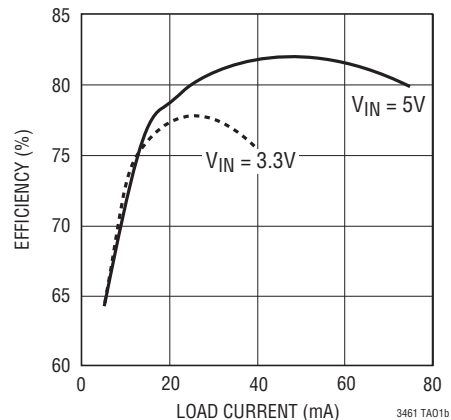

LT3461/LT3461A

ABSOLUTE MAXIMUM RATINGS

(Note 1)

Input Voltage (V_{IN}).....	16V
V_{OUT} , SW Voltage.....	40V
FB Voltage.....	5V
SHDN Voltage	16V
Operating Ambient Temperature Range (Note 2)	-40°C to 85°C
Maximum Junction Temperature	125°C
Storage Temperature Range	-65°C to 150°C
Lead Temperature (Soldering, 10 sec).....	300°C

PIN CONFIGURATION

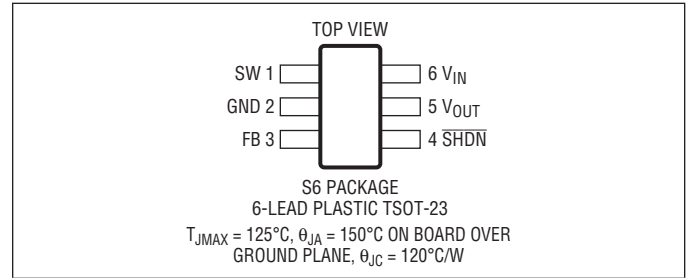

ORDER INFORMATION

LEAD FREE FINISH	TAPE AND REEL	PART MARKING	PACKAGE DESCRIPTION	TEMPERATURE RANGE
LT3461AES6#PBF	LT3461AES6#TRPBF	LTAHG	8-Lead Plastic TSOT-23	-40°C to 85°C
LT3461ES6#PBF	LT3461ES6#TRPBF	LTAEB	8-Lead Plastic TSOT-23	-40°C to 85°C

Consult LTC Marketing for parts specified with wider operating temperature ranges.

For more information on lead free part marking, go to: <http://www.linear.com/leadfree/>

For more information on tape and reel specifications, go to: <http://www.linear.com/tapeandree/>. Some packages are available in 500 unit reels through designated sales channels with #TRMPBF suffix.

ELECTRICAL CHARACTERISTICS The ● denotes the specifications which apply over the full operating temperature range, otherwise specifications are at $T_A = 25^\circ\text{C}$, $V_{IN} = 3\text{V}$, $V_{SHDN} = 3\text{V}$, unless otherwise noted.

PARAMETER	CONDITIONS	MIN	TYP	MAX	UNITS
Minimum Operating Voltage		2.5			V
Maximum Operating Voltage				16	V
Feedback Voltage		1.235 ● 1.225	1.255	1.275 1.280	V V
Feedback Line Regulation		0.005		%/V	
FB Pin Bias Current			● 40	100	nA
Supply Current	FB = 1.3V, Not Switching SHDN = 0V		2.8 0.1	3.6 0.5	mA μA
Switching Frequency (LT3461A)		● 2.1	3.0	3.9	MHz
Switching Frequency (LT3461)		● 1.0	1.3	1.7	MHz
Maximum Duty Cycle (LT3461A)		● 82			%
Maximum Duty Cycle (LT3461)		● 92			%
Switch Current Limit		300	420	600	mA
Switch V_{CESAT}	$I_{SW} = 250\text{mA}$		260	350	mV
Switch Leakage Current	$V_{SW} = 5\text{V}$		0.01	1	μA
Schottky Forward Voltage	$I_{SCHOTTKY} = 250\text{mA}$		800	1100	mV
Schottky Reverse Leakage	$V_{OUT} - SW = 40\text{V}$		0.03	4	μA
SHDN Voltage High		1.5			V
SHDN Voltage Low				0.4	V
SHDN Pin Bias Current			35	50	μA

Note 1: Stresses beyond those listed under Absolute Maximum Ratings may cause permanent damage to the device. Exposure to any Absolute Maximum Rating condition for extended periods may affect device reliability and lifetime.

Note 2: The LT3461E/LT3461AE is guaranteed to meet specifications from 0°C to 70°C . Specifications over the -40°C to 85°C operating temperature range are assured by design, characterization and correlation with statistical process controls.

TYPICAL PERFORMANCE CHARACTERISTICS

Oscillator Frequency (LT3461)

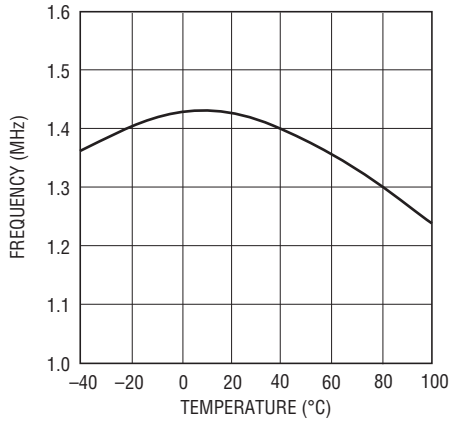

3461a G01

Current Limit

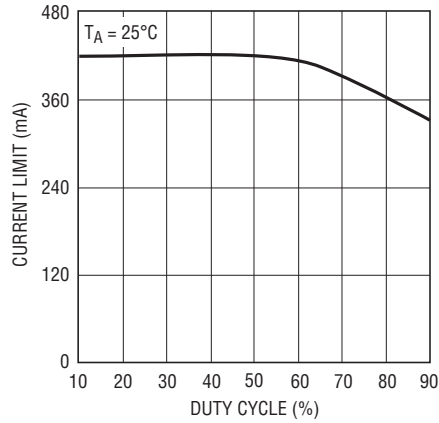

3461a G02

FB Pin Voltage

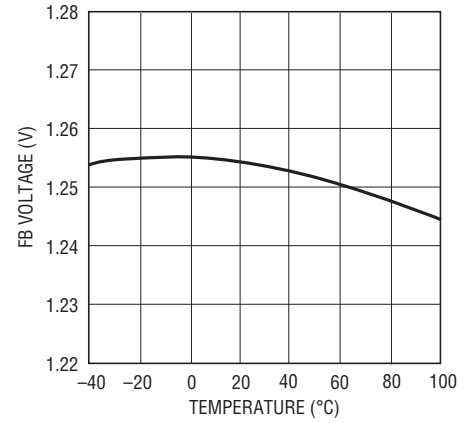

3461a G03

Oscillator Frequency (LT3461A)

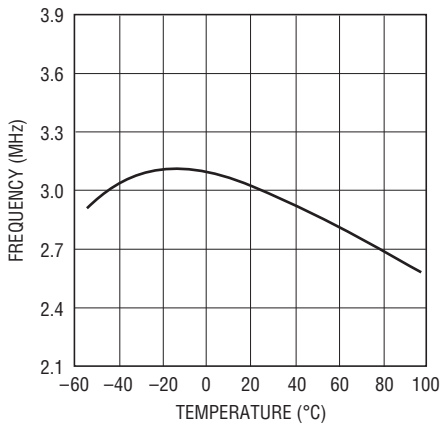

3461a G04

Current Limit in Soft-Start Mode

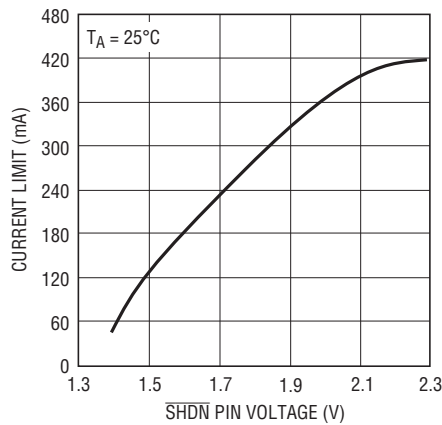

3461a G05

SHDN Pin Current

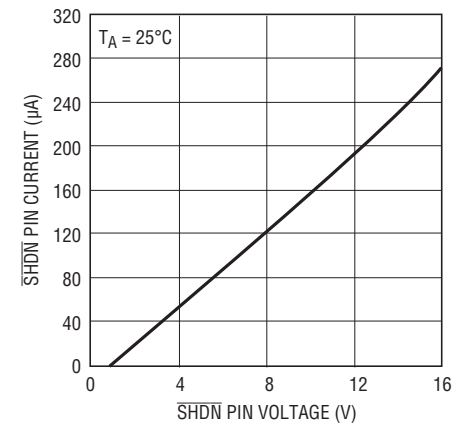

3461a G06

**Switching Waveform
Circuit of Figure 4**

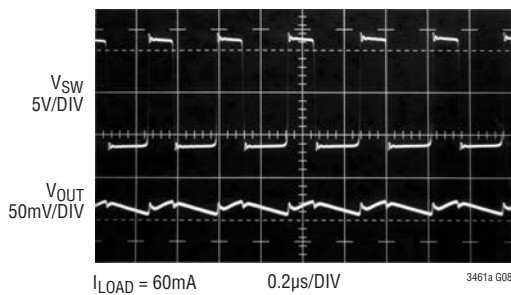

3461a G08

**Load Transient Response
Circuit of Figure 4**

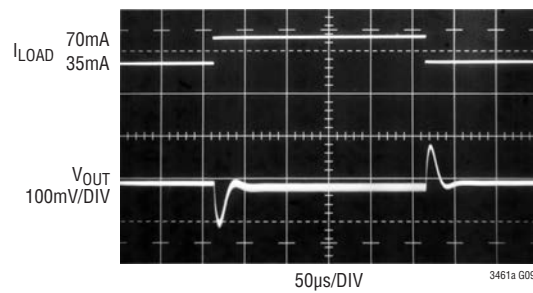

3461a G09

PIN FUNCTIONS

SW (Pin 1): Switch Pin. Connect inductor here. Minimize trace at this pin to reduce EMI.

GND (Pin 2): Ground Pin. Tie directly to local ground plane.

FB (Pin 3): Feedback Pin. Reference voltage is 1.255V. Connect resistor divider tap here. Minimize trace area at FB. Set V_{OUT} according to $V_{OUT} = 1.255V (1 + R1/R2)$.

SHDN (Pin 4): Shutdown Pin. Tie to 1.5V or higher to enable device; 0.4V or less to disable device. Also functions as soft-start. Use RC filter (47k, 47nF typ) as shown in Figure 1.

V_{OUT} (Pin 5): Output Pin. Connect to resistor divider. Put capacitor close to pin and close to GND plane.

V_{IN} (Pin 6): Input Supply Pin. Must be locally bypassed.

BLOCK DIAGRAM

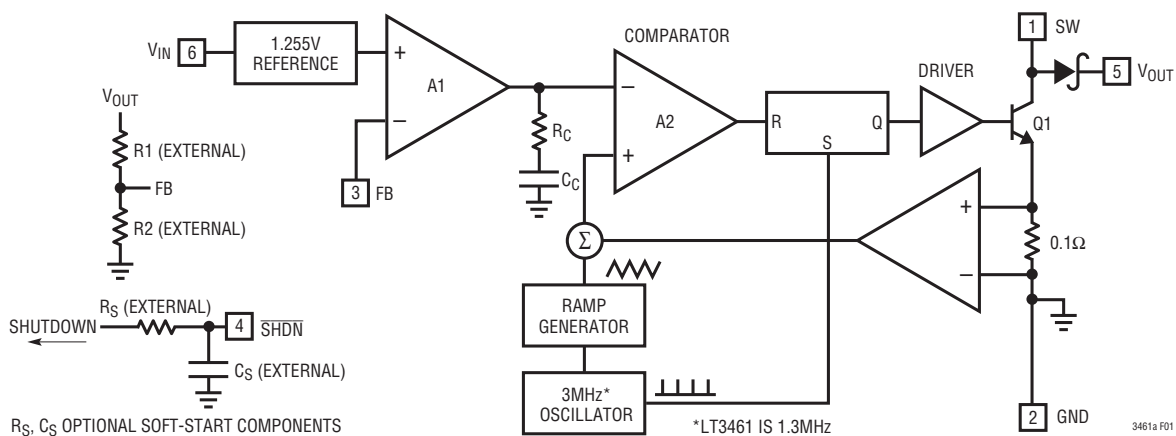

Figure 1. Block Diagram

OPERATION

The LT3461/LT3461A uses a constant frequency, current mode control scheme to provide excellent line and load regulation. Operation can be best understood by referring to the block diagram in Figure 1. At the start of each oscillator cycle, the SR latch is set, which turns on the power switch Q1. A voltage proportional to the switch current is added to a stabilizing ramp and the resulting sum is fed into the positive terminal of the PWM comparator A2. When this voltage exceeds the level at the negative input of A2, the SR latch is reset turning off the power switch. The level at the negative input of A2 is set by the error amplifier A1, and is simply an amplified version of the difference between the feedback voltage and the reference voltage of 1.255V. In this manner, the error amplifier sets the correct peak current level to keep the output in regulation. If the error amplifier's output increases, more current is delivered to the output; if it decreases, less current is delivered.

Layout Hints

The high speed operation of the LT3461/LT3461A demands careful attention to board layout. You will not get advertised performance with careless layout. Figure 2 shows the recommended component placement.

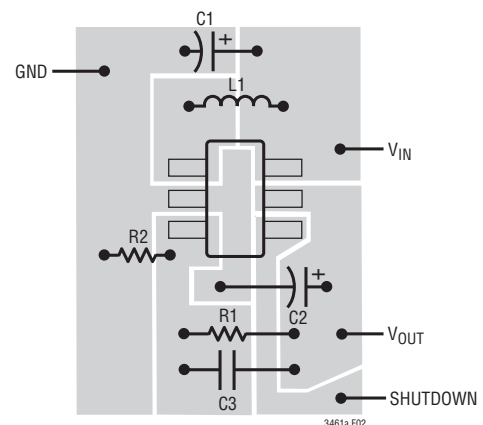

Figure 2. Suggested Layout

APPLICATIONS INFORMATION

Inrush Current

The LT3461 has a built-in Schottky diode. When supply voltage is applied to the V_{IN} pin, the voltage difference between V_{IN} and V_{OUT} generates inrush current flowing from input through the inductor and the Schottky diode to charge the output capacitor. The maximum nonrepetitive surge current the Schottky diode in the LT3461 can sustain is 1.5A. The selection of inductor and capacitor value should ensure the peak of the inrush current to be below 1.5A. In addition, turn-on of the LT3461 should be delayed until the inrush current is less than the maximum current limit. The peak inrush current can be calculated as follows:

$$I_P = \frac{V_{IN} - 0.6}{\sqrt{\frac{L}{C} - 1\Omega^2}} \exp\left(-\frac{\pi \cdot \Omega}{2\sqrt{\frac{L}{C} - 1\Omega^2}}\right)$$

where L is the inductance, r is the resistance of the inductor and C is the output capacitance.

Table 3 gives inrush peak currents for some component selections.

Table 3. Inrush Peak Current

V_{IN} (V)	L (μ H)	C (μ F)	I_P (A)
5	4.7	1	1.1
5	10	1	0.9

Thermal Considerations

Significant power dissipation can occur on the LT3461 and LT3461A, particularly at high input voltage. Device load, voltage drops in the power path components, and switching losses are the major contributors. It is important to measure device power dissipation in an application to ensure that the LT3461 does not exceed the absolute maximum operating junction temperature of 125°C over the operating ambient temperature range. Generally, for supply voltages below 5V the integrated current limit function provides adequate protection for nonfault conditions. For supply voltages above 5V, Figures 3a and 3b show the recommended operating region of the LT3461 and LT3461A, respectively. These graphs are based on 250mW on-chip dissipation. Improvement of these numbers can be expected if the LT3461 is supplied from a separate low voltage rail.

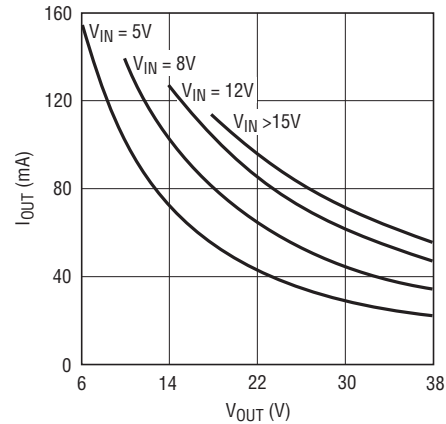

3461 F03a

Figure 3a. LT3461 Operating Region

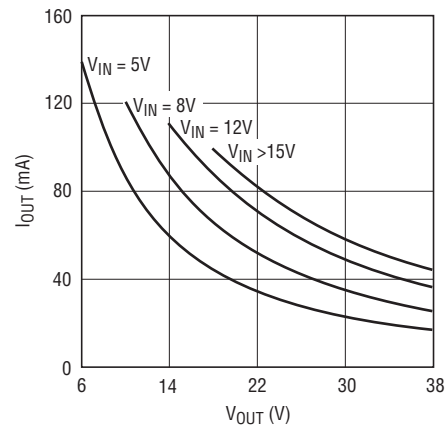

3461 F03b

Figure 3b. LT3461A Operating Region

Switching Frequency

The key difference between the LT3461 and LT3461A is the faster switching frequency of the LT3461A. At 3MHz, the LT3461A switches at twice the rate of the LT3461. The higher switching frequency of the LT3461A allows physically smaller inductors and capacitors to be used in a given application, but with a slight decrease in efficiency and maximum output current when compared to the LT3461. Generally if efficiency and maximum output current are crucial, or a high output voltage is being generated, the LT3461 should be used. If application size and cost are more important, the LT3461A will be the better choice.

APPLICATIONS INFORMATION

Inductor Selection

The inductors used with the LT3461/LT3461A should have a saturation current rating of 0.3A or greater. If the device is used in an application where the input supply will be hot-plugged, then the saturation current rating should be equal to or greater than the peak inrush current. For the LT3461, an inductor value between 10μH and 47μH, depending upon output voltage, will usually be the best choice for most designs. For the LT3461A, inductor values between 4.7μH and 15μH inductor will suffice for most applications. For best loop stability results, the inductor value selected should provide a ripple current of 70mA or more. For a given V_{IN} and V_{OUT} the inductor value to use with LT3461A is estimated by the formula:

$$L \text{ (in microhenries)} = \frac{D \cdot V_{IN} \cdot \sqrt{V_{OUT}} \cdot 1\text{sec}}{1A \cdot \sqrt{1V}}$$

$$\text{where } D = \frac{V_{OUT} + 1V - V_{IN}}{V_{OUT} + 1V}$$

Use twice this value for the LT3461.

Capacitor Selection

Low ESR capacitors should be used at the output to minimize the output voltage ripple. Multilayer ceramic capacitors using X5R/X7R dielectrics are preferred as

they have a low ESR and maintain capacitance over wide voltage and temperature range. A 2.2μF output capacitor is sufficient for most applications using the LT3461, while a 1μF capacitor is sufficient for most applications using the LT3461A. High output voltages typically require less capacitance for loop stability. Always use a capacitor with sufficient voltage rating.

Either ceramic or solid tantalum capacitors may be used for the input decoupling capacitor, which should be placed as close as possible to the LT3461/LT3461A. A 1μF capacitor is sufficient for most applications.

Phase Lead Capacitor

A small value capacitor can be added across resistor R1 between the output and the FB pin to reduce output perturbation due to a load step and to improve transient response. This phase lead capacitor introduces a pole-zero pair to the feedback that boosts phase margin near the cross-over frequency. The following formula is useful to estimate the capacitor value needed:

$$C_{PL} = \frac{500k\Omega}{R2} \cdot 1pF$$

For an application running 50μA in the feedback divider, capacitor values from 10pF to 22pF work well.

TYPICAL APPLICATIONS

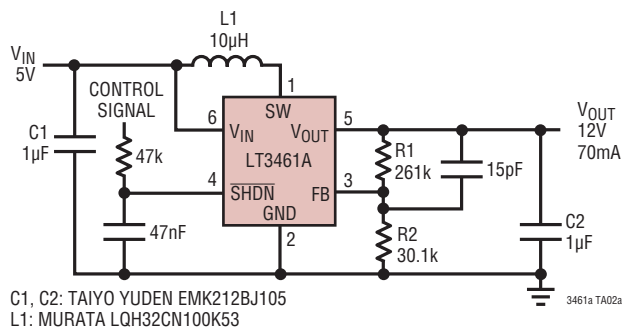
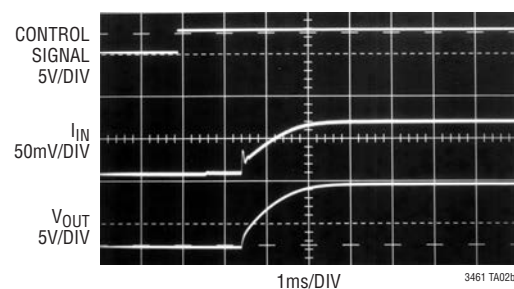

Figure 4. 5V to 12V with Soft-Start Circuit (LT3461A)

Input Current and Output Voltage



LT3461/LT3461A

TYPICAL APPLICATIONS

3.3V to 5V Step-Up Converter (LT3461A)

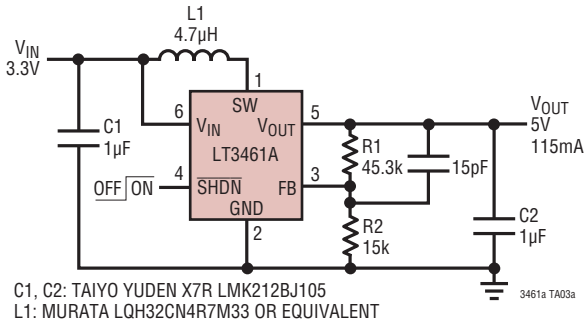

3.3V to 5V Step-Up Converter Efficiency

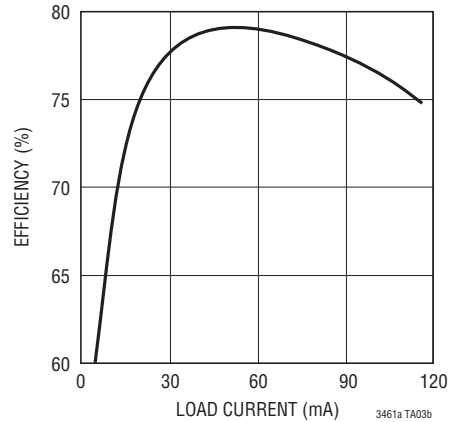

PACKAGE DESCRIPTION

Please refer to <http://www.linear.com/product/LT3461#packaging> for the most recent package drawings.

S6 Package
6-Lead Plastic TSOT-23
(Reference LTC DWG # 05-08-1636)

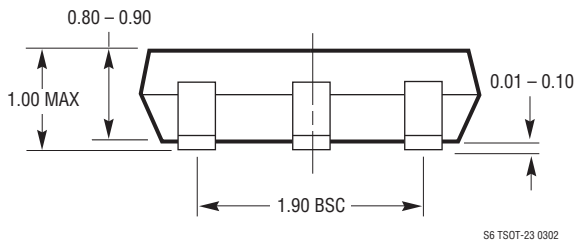
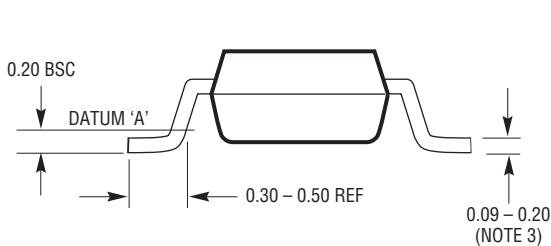
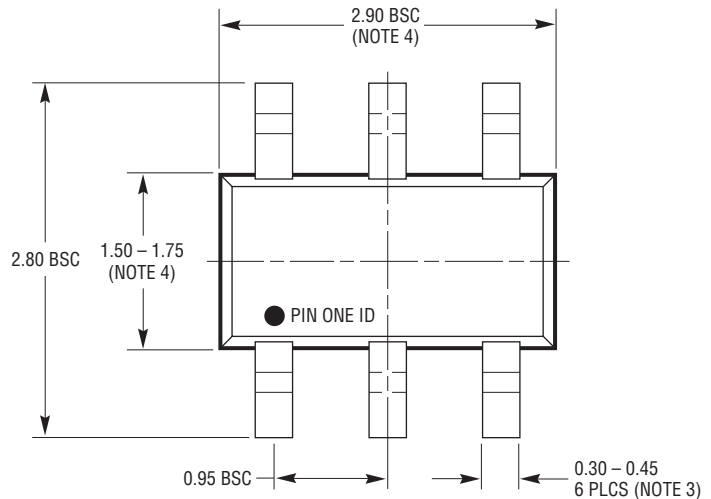
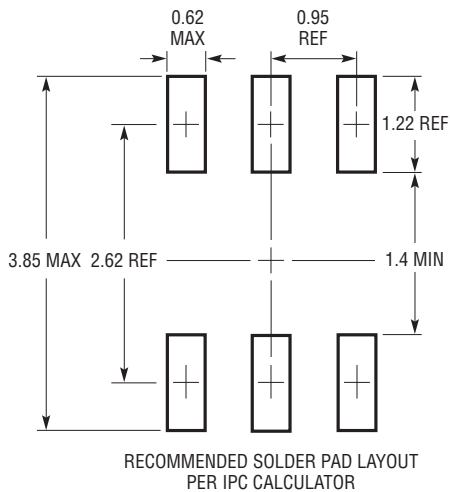

- NOTE:
1. DIMENSIONS ARE IN MILLIMETERS
 2. DRAWING NOT TO SCALE
 3. DIMENSIONS ARE INCLUSIVE OF PLATING
 4. DIMENSIONS ARE EXCLUSIVE OF MOLD FLASH AND METAL BURR
 5. MOLD FLASH SHALL NOT EXCEED 0.254mm
 6. JEDEC PACKAGE REFERENCE IS MO-193

S6 TSOT-23 0302

3461afa

REVISION HISTORY (Revision history begins at Rev B)

REV	DATE	DESCRIPTION	PAGE NUMBER
A	01/16	Modified inrush current I_P equation.	6

LT3461/LT3461A

TYPICAL APPLICATION

Low Profile (1mm) 3.3V to 15V Step-Up Converter

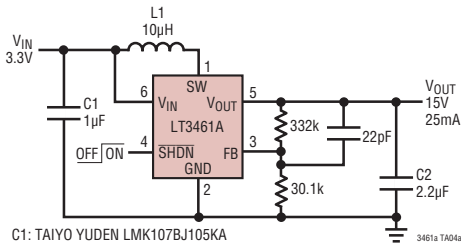

C1: TAIYO YUDEN LMK107BJ105KA
C2: TAIYO YUDEN EMK316BJ225KD (X5R)
L1: MURATA LQH2MCN100K02

3.3V to 15V Efficiency

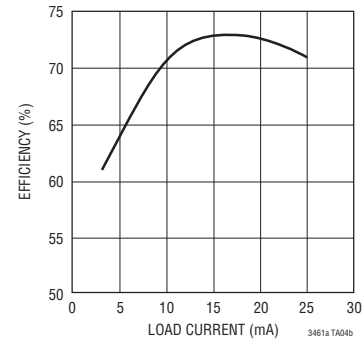

5V to 36V Step-Up Converter (LT3461)

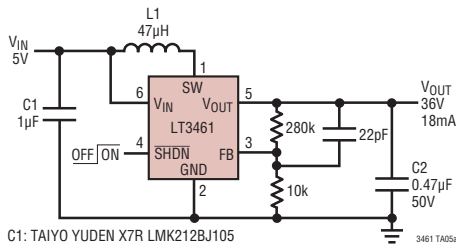

C1: TAIYO YUDEN X7R LMK212BJ105
C2: MURATA GRM42-6X7R474K50
L1: MURATA LQH32CN470

5V to 36V Efficiency

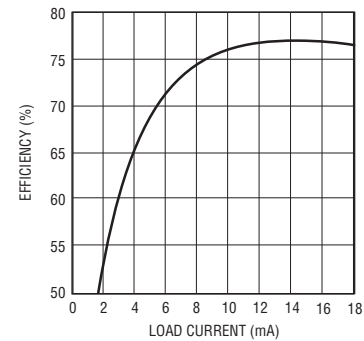

3.3V to ±5V Dual Output Converter

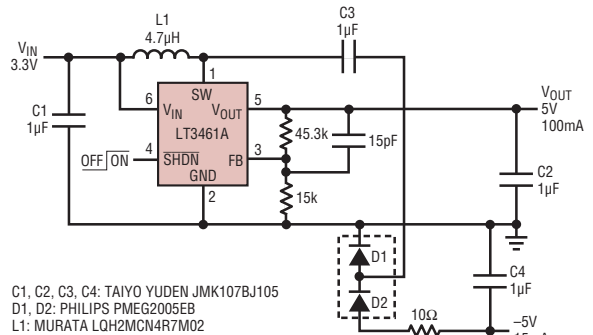

C1, C2, C3, C4: TAIYO YUDEN JMK107BJ105
D1, D2: PHILIPS PMEG2005EB
L1: MURATA LQH2MCN4R7M02

RELATED PARTS

PART NUMBER	DESCRIPTION	COMMENTS
LT1615/LT1615-1	300mA/80mA (I_{SW}) Constant Off-Time, High Efficiency Step-Up DC/DC Converter	V_{IN} : 1.2V to 15V, $V_{OUT(MAX)}$ = 34V, I_Q = 20µA, I_{SD} < 1µA, ThinSOT Package
LT1944/LT1944-1	Dual Output 350mA/100mA (I_{SW}), Constant Off-Time, High Efficiency Step-Up DC/DC Converter	V_{IN} : 1.2V to 15V, $V_{OUT(MAX)}$ = 34V, I_Q = 20µA, I_{SD} < 1µA, MS Package
LTC3400/LTC3400B	600mA (I_{SW}), 1.2MHz, Synchronous Step-Up DC/DC Converter	V_{IN} : 0.85V to 5V, $V_{OUT(MAX)}$ = 5V, I_Q = 19µA/300µA, I_{SD} < 1µA, ThinSOT Package
LT3460	0.32A (I_{SW}), 1.3MHz, High Efficiency Step-Up DC/DC Converter	V_{IN} : 2.5V to 16V, $V_{OUT(MAX)}$ = 36V, I_Q = 2mA, I_{SD} < 1µA, SC70, ThinSOT Packages
LT3465/LT3465A	Constant Current, 1.2MHz/2.7MHz, High Efficiency White LED Boost Regulator with Integrated Schottky Diode	V_{IN} : 2.7V to 16V, $V_{OUT(MAX)}$ = 34V, I_Q = 1.9mA, I_{SD} < 1µA, ThinSOT Package

3461afa

Looking for pricing, stock, or lifecycle information?

Click below to explore more details on WIN SOURCE:

 [View LT3461AES6#TRMPBF on WIN SOURCE](#)

 [Linear Technology](#) Information

Optimize Your Supply Chain with WIN SOURCE Solutions

-  Global Sourcing Solution
-  Obsolete Management
-  Cost Control Management
-  Shortage Management
-  Alternative Solution
-  Excess Inventory Management