



**THE DATASHEET OF
LT3464ETS8#TRMPBF**



Micropower Boost Converter with Schottky and Output Disconnect in ThinSOT™

FEATURES

- Tiny Solution Size
- Low Quiescent Current
 - 25 μ A in Active Mode
 - 0.5 μ A in Shutdown Mode
- Internal 115mA, 36V Switch
- Integrated Schottky Diode
- Integrated PNP Output Disconnect with Short-Circuit Protection
- Internal Reference Override Pin
- 16V at 8mA from 3.6V Input
- 12V at 20mA from 5V Input
- Input Range: 2.3V to 10V
- High Output Voltage: Up to 34V
- Low Profile (1mm) SOT-23 Package

APPLICATIONS

- OEL Panel Bias
- LCD Bias
- Handheld Computers
- Battery Backup
- Digital Cameras
- Cellular Phones

DESCRIPTION

The LT[®]3464 is a micropower step-up DC/DC converter with integrated Schottky diode and output disconnect packaged in an 8-lead low profile (1mm) SOT-23. The small package size, high level of integration, and the use of tiny SMT components yield a solution size of less than 40mm². The LT3464 has a typical current limit of 115mA as well as fast switching speed to allow the use of a chip inductor and small ceramic capacitors. The internal PNP disconnects the output load from the input during shutdown, and also provides output short-circuit protection. An auxiliary reference input allows the user to override the internal 1.25V feedback reference with any lower value, allowing full control of the output voltage during operation. This device features a low 25 μ A quiescent current, which is further reduced to less than 0.5 μ A in shutdown. A current limited fixed off-time control scheme conserves operating current, resulting in high efficiency over a broad range of operating current. The rugged 36V switch and output disconnect circuitry allow outputs up to 34V to be easily generated in a simple boost topology.

LT, LTC and LT are registered trademarks of Linear Technology Corporation.
ThinSOT is a trademark of Linear Technology Corporation

TYPICAL APPLICATION

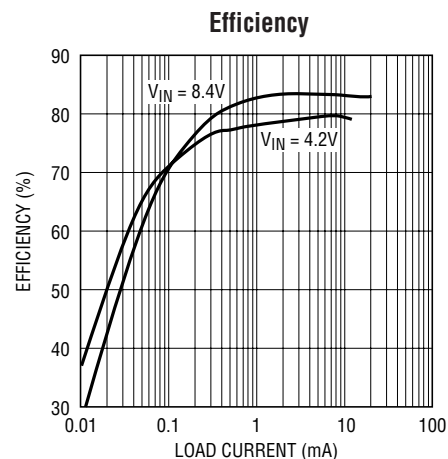
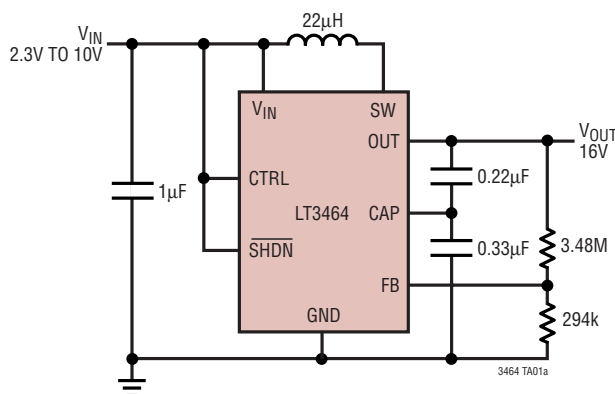

ABSOLUTE MAXIMUM RATINGS

(Note 1)

V_{IN} , \overline{SHDN} , CTRL Voltage	10V
OUT, CAP Voltage	36V
SW Voltage	36V
FB Voltage	6V
Maximum Junction Temperature	125°C
Operating Temperature Range (Note 2) ..	-40°C to 85°C
Storage Temperature Range	-65°C to 150°C
Lead Temperature (Soldering, 10 sec).....	300°C

PACKAGE/ORDER INFORMATION

<p>TOP VIEW</p> <p>CTRL 1 8 SHDN</p> <p>FB 2 7 VIN</p> <p>OUT 3 6 SW</p> <p>GND 4 5 CAP</p> <p>TS8 PACKAGE 8-LEAD PLASTIC SOT-23</p> <p>$T_{JMAX} = 125^{\circ}C$, $\theta_{JA} = 140^{\circ}C/W$, $\theta_{JC} = 85^{\circ}C/W$</p>	ORDER PART NUMBER
	LT3464ETS8
	TS8 PART MARKING
	LTG2

Consult LTC Marketing for parts specified with wider operating temperature ranges.

ELECTRICAL CHARACTERISTICS The ● denotes the specifications which apply over the full operating temperature range, otherwise specifications are at $T_A = 25^{\circ}C$. $V_{IN} = 3.6V$, unless otherwise noted. (Note 2)

PARAMETER	CONDITIONS	MIN	TYP	MAX	UNITS
Minimum Input Voltage			2.0	2.3	V
Quiescent Current	Not Switching $V_{\overline{SHDN}} = 0.2V$		25 0.01	36 0.5	μA μA
FB Comparator Trip Voltage	V_{FB} Falling, $V_{CTRL} = 3.6V$	● 1.215	1.250	1.275	V
FB Comparator Hysteresis			10		mV
FB Pin Bias Current	$V_{FB} = 1.25V$, $V_{CTRL} = 3.6V$	●	3	30	nA
FB Voltage Line Regulation	$2.3V < V_{IN} < 10V$		0.05	0.1	%/V
Switch Off Time	$V_{CAP} - V_{IN} = 5V$ $V_{CAP} - V_{IN} = 0V$		250 1.0		ns μs
Switch Leakage Current	$V_{SW} = 36V$		0.02	1	μA
Switch V_{CESAT}	$I_{SW} = 80mA$		190	300	mV
Switch Current Limit		85	115	140	mA
Schottky Forward Voltage	$I_{SCHOTTKY} = 110mA$		600	750	mV
Schottky Reverse Leakage	$V_{CAP-SW} = 36V$		1	10	μA
PNP Disconnect $V_{CAP-OUT}$	$I_{OUT} = 200\mu A$ $I_{OUT} = 10mA$		100 190		mV mV
PNP Disconnect Q Current	$I_{OUT} = 0$, $V_{CAP} = 36V$ (Note 3)		1.5	5	μA
PNP Disconnect Leakage	$\overline{SHDN} = 0.2$, $V_{CAP} = 10V$, $V_{OUT} = 0V$		0.1	5	μA
PNP Disconnect Current Limit	$V_{CAP} = 10V$, $V_{OUT} = 0V$	25	45	75	mA
\overline{SHDN} Pin Current	$V_{\overline{SHDN}} = 3.6V$		5	10	μA
\overline{SHDN} Input Voltage High		2.3			V
\overline{SHDN} Input Voltage Low				0.2	V
CTRL Pin Bias Current	$V_{CTRL} = 0.5V$, $V_{FB} = 1V$	●	6	80	nA
CTRL to FB Offset	$V_{CTRL} = 0.5V$ (Note 4)		2	7	mV

Note 1: Absolute Maximum Ratings are those values beyond which the life of a device may be impaired.

Note 2: The LT3464E is guaranteed to meet performance specifications from 0°C to 70°C. Specifications over the -40°C to 85°C operating temperature range are assured by design, characterization and correlation with statistical process controls.

Note 3: Current consumed by Disconnect PNP when there is no load on the OUT pin.

Note 4: This figure is computed according to $((V_{FB} \text{ falling} + V_{FB} \text{ rising})/2) - V_{CONTROL}$.

TYPICAL PERFORMANCE CHARACTERISTICS

Switch Saturation Voltage
 $I_{SW} = 80\text{mA}$

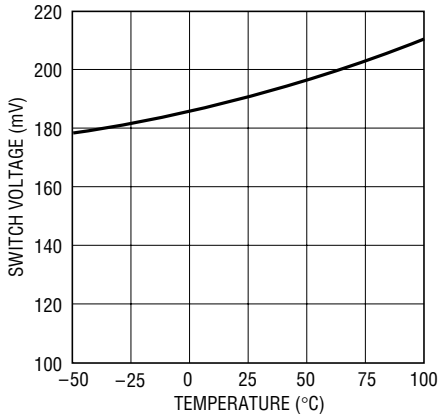

3464 G01

Switch Current Limit

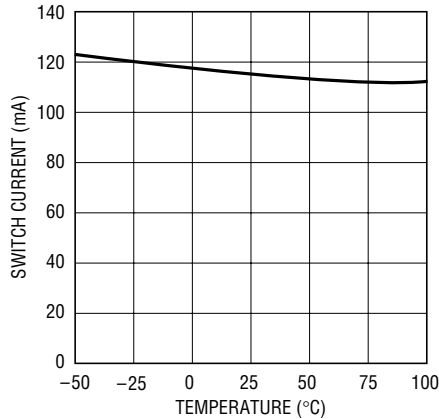

3464 G02

Switch Off-Time, $V_{CAP} - V_{IN} = 5\text{V}$

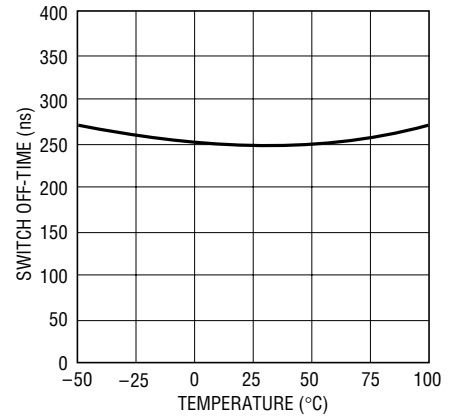

3464 G03

Minimum Switch On-Time

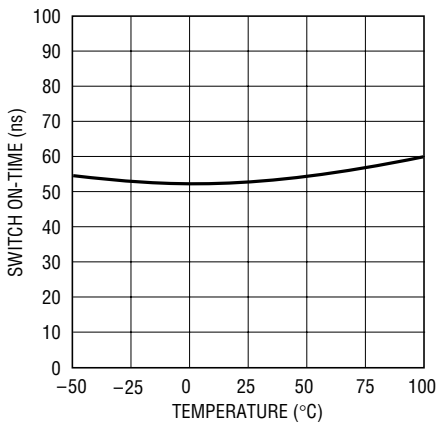

3464 G04

Switch Off-Time, $V_{CAP} - V_{IN} = 0\text{V}$

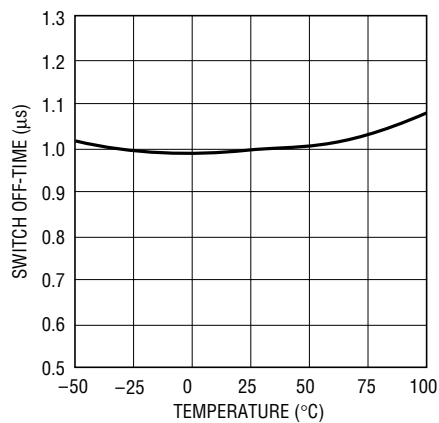

3464 G05

Output Disconnect Voltage Drop

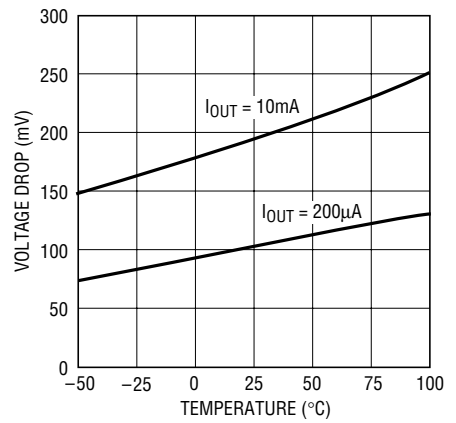

3464 G06

Output Disconnect Quiescent Current

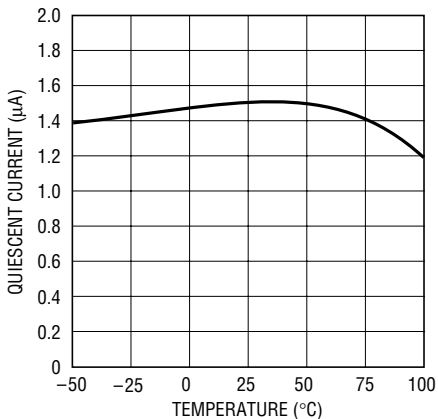

3464 G07

Output Disconnect Current Limit

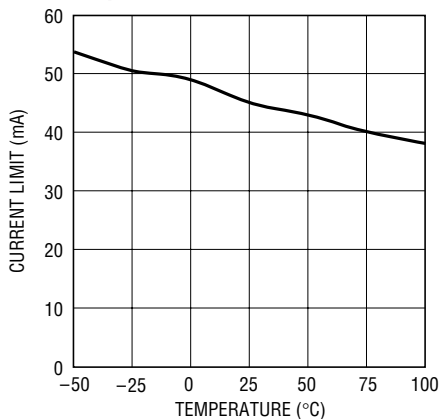

3464 G08

Output Disconnect Voltage Drop

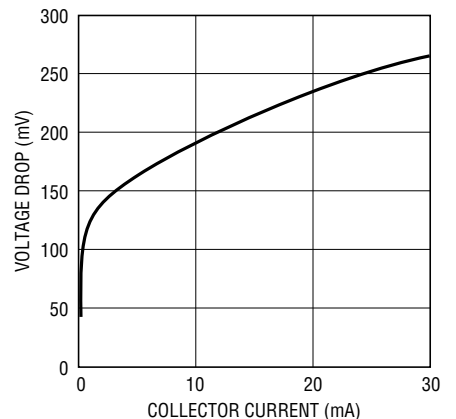

3464 G09

TYPICAL PERFORMANCE CHARACTERISTICS

Schottky Forward Drop at $I_D = 110\text{mA}$

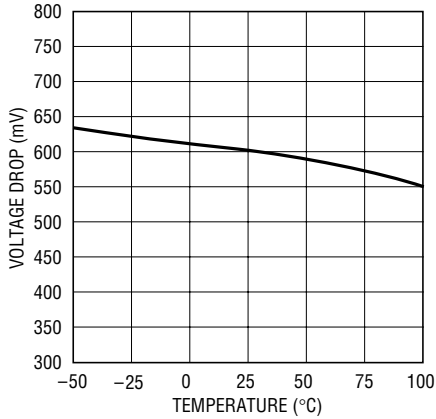

3464 G10

Schottky Forward Voltage

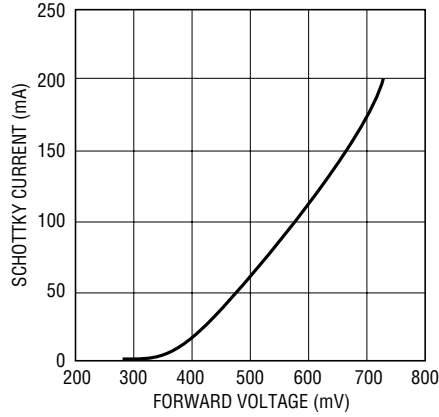

3464 G11

Schottky Reverse Leakage

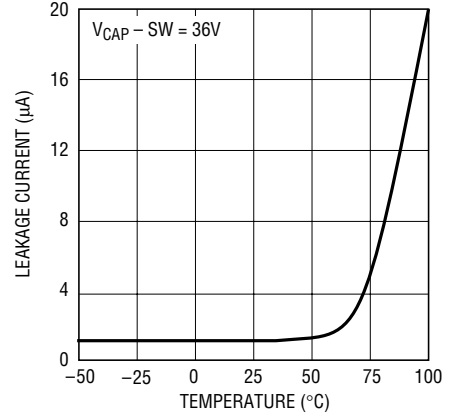

3464 G20

Quiescent Current

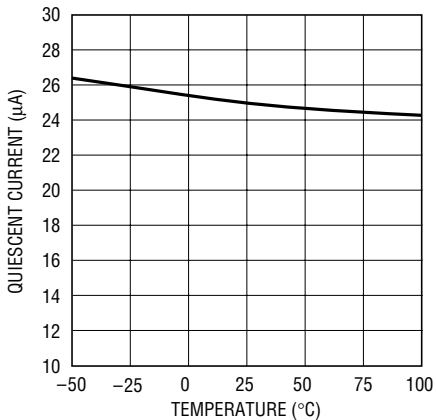

3464 G12

Shutdown Pin Current $V_{SHDN} = 3.6\text{V}$

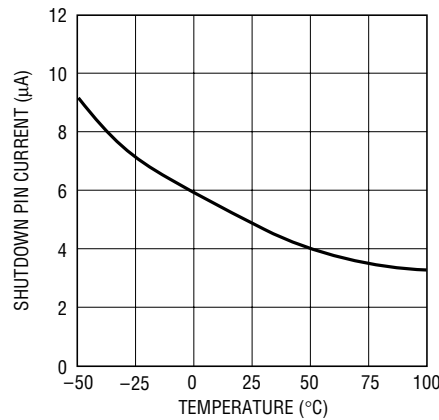

3464 G13

Quiescent Current in Shutdown Mode

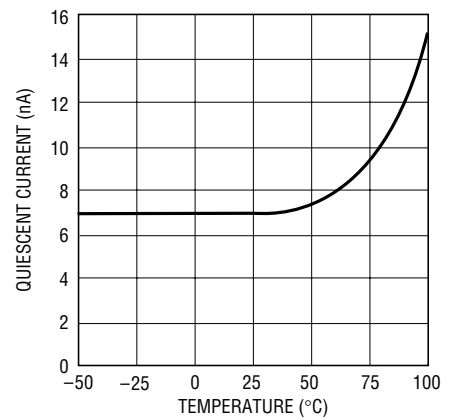

3464 G14

Quiescent Current in Regulation with No Load

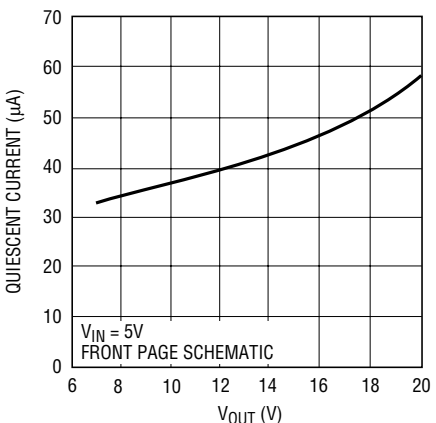

3464 G18

SHDN Pin Threshold Voltage

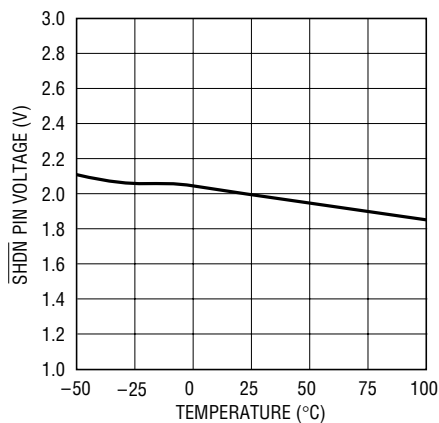

3464 G15

FB Pin Voltage

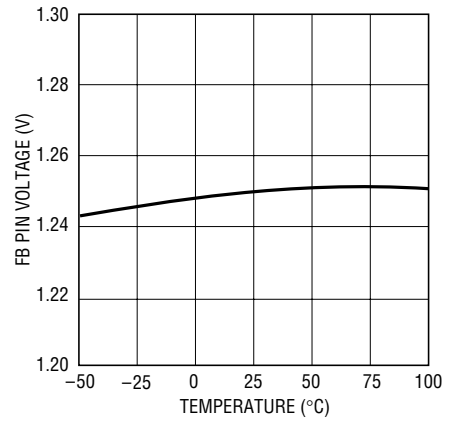

3464 G16

TYPICAL PERFORMANCE CHARACTERISTICS

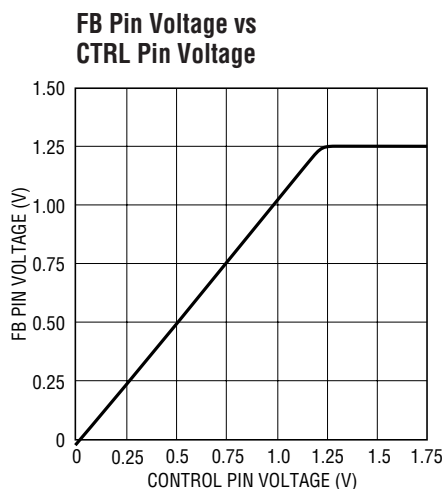

3464 G17

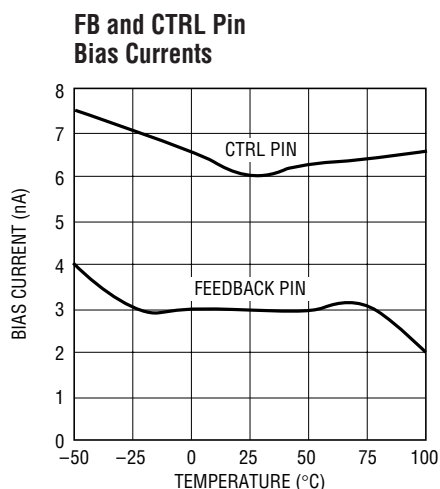

3464 G18

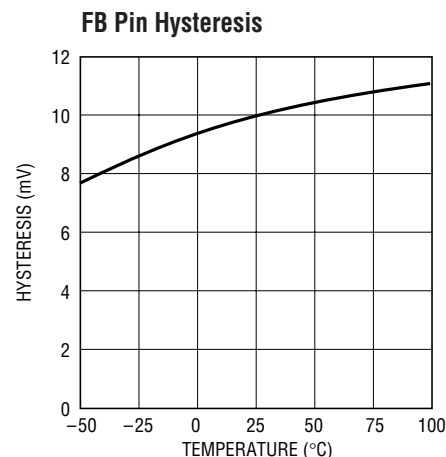

3464 G19

PIN FUNCTIONS

CTRL (Pin 1): Internal Reference Override Pin. This allows the FB voltage to be externally set between 0V and 1.25V. Tie this pin to above 1.5V (V_{IN} for example) to use the internal 1.25V reference.

$$V_{OUT} = V_{CTRL} \left(\frac{R2}{R1} + 1 \right)$$

when V_{CTRL} is less than 1.25V (see Figure 4)

FB (Pin 2): Feedback Pin. The LT3464 regulates its feedback pin to 1.25V if the internal reference is used or to V_{CTRL} if the CTRL pin is between 0V and 1.25V. Connect the feedback resistor divider tap to this pin. Set the output voltage by selecting R1 and R2 (see Figure 4).

$$R2 = R1 \left(\frac{V_{OUT}}{V_{REF}} - 1 \right)$$

OUT (Pin 3): PNP Collector. This is the output of the Output Disconnect circuit. Bypass this pin with at least a 0.1 μ F capacitor connected to the CAP pin or to ground.

GND (Pin 4): Ground. Tie this pin directly to the ground plane.

CAP (Pin 5): PNP Emitter and Schottky Cathode. This pin connects to the output capacitor, and optionally to the external phase-lead capacitor.

SW (Pin 6): Switch Pin and Schottky Anode. This is the collector of the internal NPN power switch. Minimize the metal trace area connected to the pin to minimize EMI.

V_{IN} (Pin 7): Input Supply Pin: Bypass this pin with a capacitor located as close to the device as possible.

SHDN (Pin 8): Shutdown Pin. This pin is used to put the device in shutdown mode. Tie the pin low to shut down the LT3464. Tie high for normal operation. See the electrical specifications for the required voltages.

BLOCK DIAGRAM

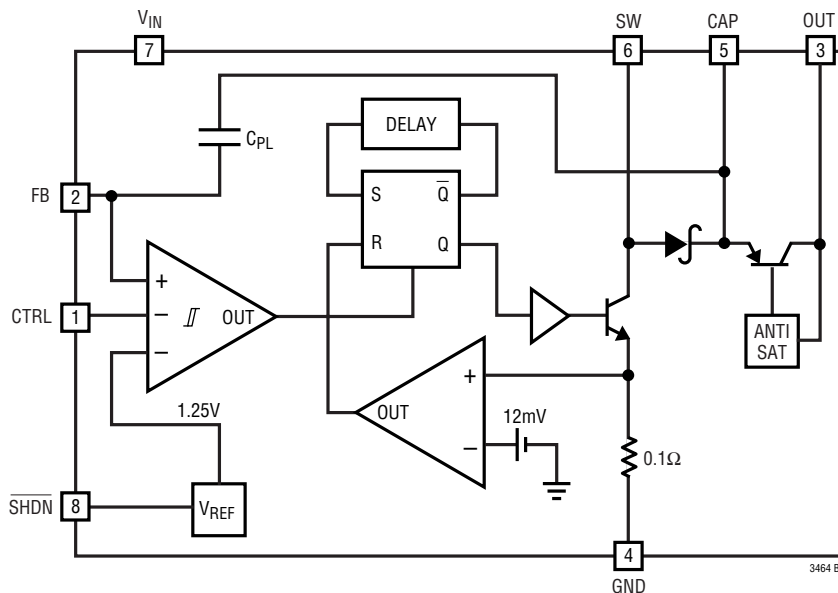

OPERATION

The LT3464 uses a constant off-time control scheme in conjunction with Burst Mode[®] operation to provide high efficiency over a wide range of output current. Operation can best be understood by studying the Block Diagram. When the FB pin voltage is lower than the 1.25V reference, the hysteretic comparator enables the power section, causing the chip to start switching, thus charging the output capacitor. When the output voltage increases enough to overcome the hysteresis, the feedback comparator shuts off the power section leaving only low power circuitry running until the output voltage falls again. This cycle repeats, keeping the output voltage within a small window. The switching action is as follows: The switch turns on, and current through it starts to ramp up until the

point where the current limit is reached, at which point the switch turns off for a fixed amount of time. While the switch is off the inductor is delivering current to the load. When the off time expires, the switch turns on again until the current limit is reached, and the cycle repeats.

This chip includes an internal power Schottky diode and a PNP transistor for output disconnect. The PNP transistor disconnects the load from the input during shutdown. The PNP control circuitry is designed to keep the PNP out of saturation across a wide range of current, to keep quiescent current to a minimum and to provide current limiting to protect the chip during short-circuit conditions.

Burst Mode is a registered trademark of Linear Technology Corporation.

SWITCHING TIME WAVEFORMS

Operating Waveforms

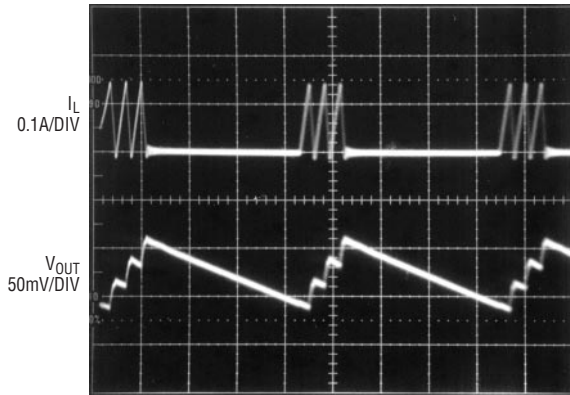

$V_{IN} = 5V$
 $V_{OUT} = 20V$
 $I_{LOAD} = 1mA$
 $L = 22\mu H$

Start up Waveforms

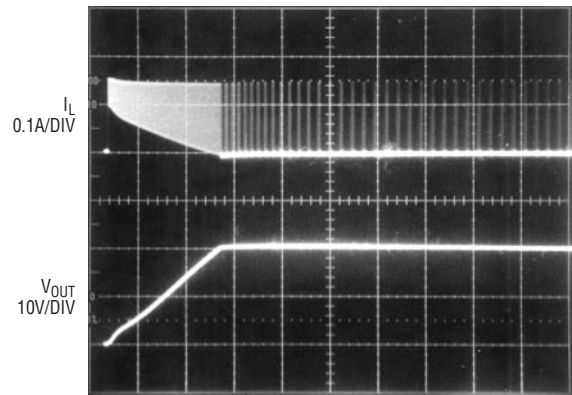

Shutdown Waveforms

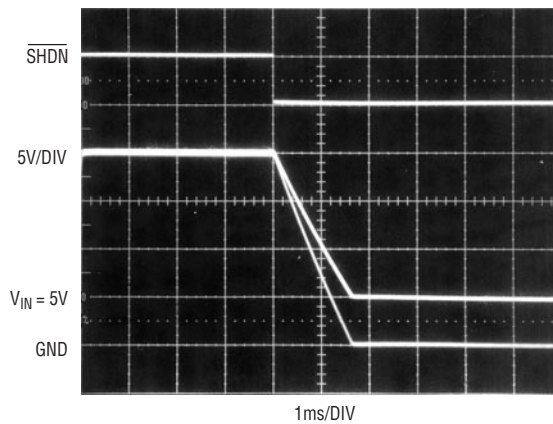

CAP PIN VOLTAGE
 V_{OUT} : THE OUTPUT DISCONNECT
 ALLOWS V_{OUT} TO BE AT
 GROUND DURING SHUTDOWN

APPLICATIONS INFORMATION

Choosing an Inductor

The low current limit and fast switching of the LT3464 allow the use of very small surface mount inductors. The minimum inductor size that may be used in a given application depends on required efficiency and output current. Some inductors that work with the LT3464 are listed in Table 1, although there are many other manufacturers and devices that can be used. Consult each manufacturer for more detailed information and for their entire selection of related parts. Many different sizes and shapes are available.

Table 1. Recommended Inductors

PART NUMBER	μH	DCR (Ω)	CURRENT (mA)	MANUFACTURER
LQH32CN680K53	68	2.2	130	Murata
LQH32CN470K53	47	1.3	170	814-237-1431
LQH32CN220K53	22	0.71	250	www.murata.com
ELJPC220KF	22	4.0	160	Panasonic
ELJPA470KF	47	2.25	135	714-373-7334 www.panasonic.com
CMD4D11-47	47	2.2	180	Sumida 847-956-0666 www.Sumida.com
LB2016-220	22	1.0	105	Taiyo Yuden
LEM2520-220	22	5.5	125	408-573-4150
LEM2520-330	33	7.1	110	www.t-yuden.com
LEMC2520-220	22	2.7	160	
LEMC2520-330	33	4.8	120	
LEMF2520-220	22	1.2	105	
LEMC3225-680	68	3.3	120	
LEMC3225-101	100	4.3	100	

The following set of formulas can be used to calculate maximum output current given V_{IN} , V_{OUT} and L values. Inequality 1 is used to determine if the LT3464 is operating

in discontinuous mode. If the left hand side of inequality 1 evaluates to less than t_{OFF} , then use Equation 3 to calculate maximum output current. Otherwise, use Equation 2.

This inequality is true when the LT3464 is operating in discontinuous mode.

$$\frac{L I_{LIM}}{(V_{OUT} - V_{IN} + V_F)} < t_{OFF} \quad (\text{INEQUALITY 1})$$

Use this equation to calculate the maximum output current when the LT3464 is operating in continuous mode.

$$I_{OUT(CM)} = \frac{(2L I_{LIM} + t_{OFF}(V_{IN} - V_{OUT} - V_F))(V_{IN} - V_{CESAT})}{2L(V_{OUT} - V_{CESAT} + V_F)} \quad (2)$$

Use this equation to calculate the maximum output current when the LT3464 is operating in discontinuous mode.

$$I_{OUT(DCM)} = \frac{L I_{LIM}^2 (V_{IN} - V_{CESAT})}{2(L I_{LIM} + V_{IN} t_{OFF} - t_{OFF} V_{CESAT})(-V_{IN} + V_{OUT} + V_F)} \quad (3)$$

Where V_F is the Schottky forward voltage, I_{LIM} is the switch current limit, t_{OFF} is the switch off time, and V_{CESAT} is the switch saturation voltage. See the Electrical Specifications. Figures 1 through 3 show the worst-case maximum output current as given by Equations 2 and 3 using 20% inductor derating and worst-case LT3464 specifications. Also note that for some applications the maximum output current is limited to 25mA by the output disconnect circuitry.

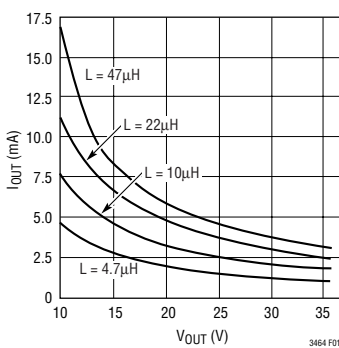

Figure 1. Maximum Output Current
 $V_{IN} = 3.6V$

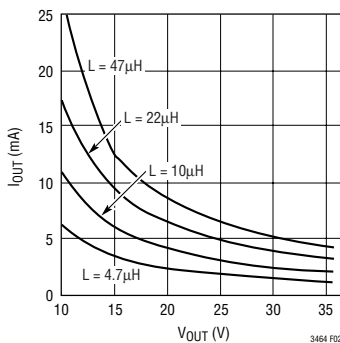

Figure 2. Maximum Output Current
 $V_{IN} = 5V$

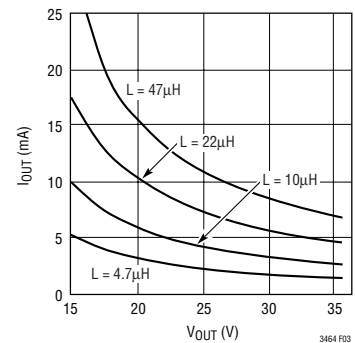

Figure 3. Maximum Output Current
 $V_{IN} = 8.4V$

APPLICATIONS INFORMATION

Capacitor Selection

The small size and low ESR of ceramic capacitors makes them suitable for LT3464 applications. X5R and X7R types are recommended because they retain their capacitance over wider voltage and temperature ranges than other types such as Y5V or Z5U. A 1 μF input capacitor and a 0.22 μF to 0.47 μF output capacitor are sufficient for most LT3464 applications. Always use a capacitor with a sufficient voltage rating. Table 2 shows a list of several capacitor manufacturers. Consult the manufacturers for more detailed information and for their entire selection of related parts.

Table 2. Recommended Ceramic Capacitor Manufacturers

MANUFACTURER	PHONE	URL
Taiyo Yuden	408-573-4150	www.t-yuden.com
AVX	843-448-9411	www.avxcorp.com
Murata	814-237-1431	www.murata.com
Kemet	408-986-0424	www.kemet.com

Output Voltage Ripple

Using low ESR capacitors will help minimize the output ripple voltage, but proper selection of the inductor and the output capacitor also plays a big role. The LT3464 provides energy to the load in bursts by ramping up the inductor current, then delivering that current to the load. If too large an inductor value or too small a capacitor value is used, the output ripple voltage will increase because the capacitor will be slightly overcharged each burst cycle. To reduce this effect, a larger output capacitor may be used.

The LT3464 also includes an on-chip phase-lead capacitor between the CAP pin and the FB pin to greatly reduce ripple; however, certain applications can benefit from additional capacitance in parallel with the integrated capacitor, which may be added externally between the CAP and FB pins. Typical effective values range from 4.7pF to 20pF. Since the FB pin sits at a low voltage, be sure the chosen capacitor has a sufficient voltage rating.

Setting Output Voltage and the Auxiliary Reference Input

The LT3464 is equipped with both an internal 1.25V reference and an auxiliary reference input. This allows the

user to select between using the built-in reference, and supplying an external reference voltage. The voltage at the CTRL pin can be adjusted while the chip is operating to alter the output voltage of the LT3464 for purposes such as display dimming or contrast adjustment. To use the internal 1.25V reference, the CTRL pin must be held higher than 1.5V, which can be done by tying it to V_{IN} . When the CTRL pin is held between 0V and 1.2V the LT3464 will regulate the output such that the FB pin voltage is equal to the CTRL pin voltage.

To set the output voltage, select the values of R1 and R2 according to the following equation (see Figure 4).

$$R2 = R1 \left(\frac{V_{OUT}}{V_{REF}} - 1 \right)$$

Where $V_{REF} = 1.25\text{V}$ if the internal reference is used, or $V_{REF} = V_{CTRL}$ if V_{CTRL} is between 0V and 1.2V.

Choosing a Feedback Node

The top of the feedback divider may be connected to the OUT pin or to the CAP pin (see Figure 4). Regulating the OUT pin eliminates the output offset resulting from the voltage drop across the output disconnect. However, in the case of a short-circuit fault at the OUT pin, the LT3464 will switch continuously because the FB pin is low. While operating in this open-loop condition, the rising voltage at the CAP pin is limited only by the current limit of the output disconnect. Given worst-case parameters this voltage may reach 25V. When the short-circuit is removed, the OUT pin will bounce up to the voltage on the CAP pin, potentially exceeding the set output voltage until the capacitor voltages fall back into regulation. While this is harmless to the LT3464, this should be considered in the context of the external circuitry if short-circuit events are expected.

Regulating the CAP pin ensures that the voltage on the OUT pin never exceeds the set output voltage after a short-circuit event. However, this setup does not compensate for the voltage drop across the output disconnect, resulting in an output voltage that is slightly lower than the voltage set by the resistor divider. The next section discusses how to compensate for this drop.

APPLICATIONS INFORMATION

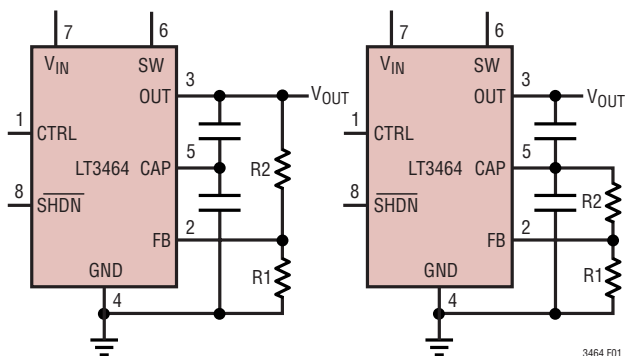

Figure 4. Feedback Connection Using the CAP Pin and the OUT Pin

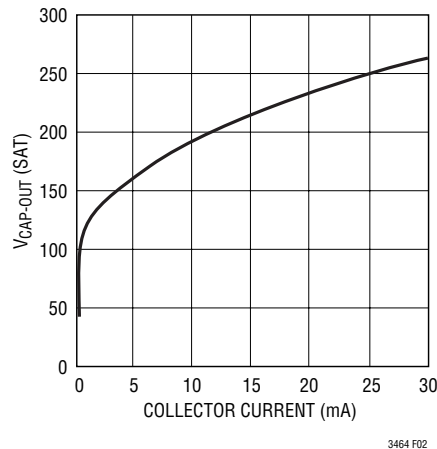

Figure 5: Output Disconnect Voltage Drop (V_{DROP}) vs Current

Output Disconnect Considerations

The LT3464 is equipped with an output disconnect that isolates the load from the input during shutdown. See the Operation section for a functional diagram. The output disconnect uses a pass PNP coupled with circuitry that varies the base current such that the transistor is consistently at the edge of saturation, thus yielding the best compromise between $V_{CE(SAT)}$ and low quiescent current. To remain stable, this circuit requires a bypass capacitor connected between the OUT pin and the CAP pin or between the OUT pin and ground. A ceramic capacitor with a value of at least $0.1\mu F$ is a good choice.

The PNP $V_{CE(SAT)}$ varies with load current as shown in Figure 5. This voltage drop (V_{DROP}) can be accounted for when using the CAP pin as the feedback node by setting the output voltage according to the following formula:

$$R2 = R1 \left(\frac{V_{OUT} + V_{DROP}}{V_{REF}} - 1 \right)$$

In addition, the disconnect circuit has a built in current limit of 25mA (minimum) to protect the chip during short-circuit. This feature allows the LT3464 to tolerate an

indefinite short, but care must be taken to avoid exceeding the maximum junction temperature.

Inrush Current

When V_{IN} is stepped from ground to operating voltage while the output capacitor is discharged, an inrush current will flow through the inductor and integrated Schottky diode into the output capacitor. Conditions that increase inrush current include a larger more abrupt voltage step at V_{IN} , a larger output capacitor tied to the CAP pin, and an inductor with a low saturation current.

While the internal diode is designed to handle such events, the inrush current should not be allowed to exceed 1 amp. For circuits that use output capacitor values within the recommended range and have input voltages of less than 5V, inrush current remains low, posing no hazard to the device. In cases where there are large steps at V_{IN} (more than 5V) and/or a large capacitor is used at the CAP pin, inrush current should be measured to ensure safe operation.

APPLICATIONS INFORMATION

Board Layout Considerations

As with all switching regulators, careful attention must be paid to the PCB board layout and component placement. To maximize efficiency, switch rise and fall times are made as short as possible. To prevent electromagnetic interference (EMI) problems, proper layout of the high frequency switching path is essential. The voltage signal of the SW

pin has sharp rising and falling edges. Minimize the length and area of all traces connected to the SW pin and always use a ground plane under the switching regulator to minimize interplane coupling. In addition, the ground connection for the feedback resistor R1 should be tied directly to the GND pin and not shared with any other component, ensuring a clean, noise-free connection. Recommended component placement is shown in Figure 6.

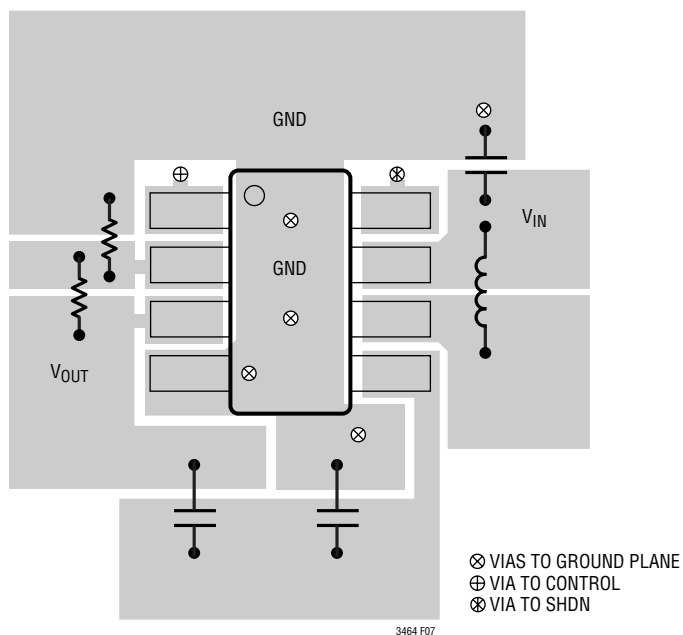
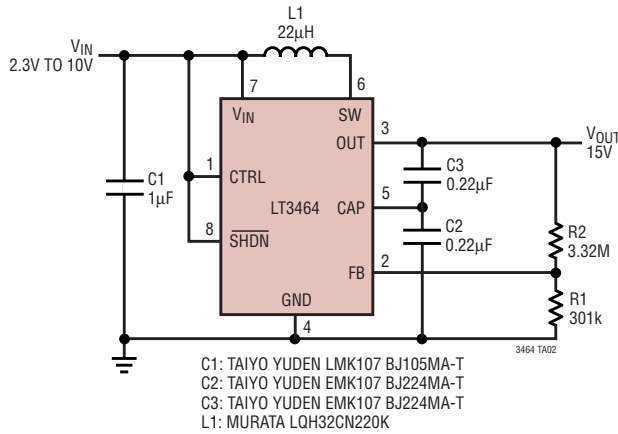

Figure 6. Recommended Layout

TYPICAL APPLICATIONS

15V Output Converter with Output Disconnect



V _{IN} (V)	I _{OUT} (mA)
3.6	7.0
5.0	10.0
8.4	19.0

34V Output Converter with Output Disconnect

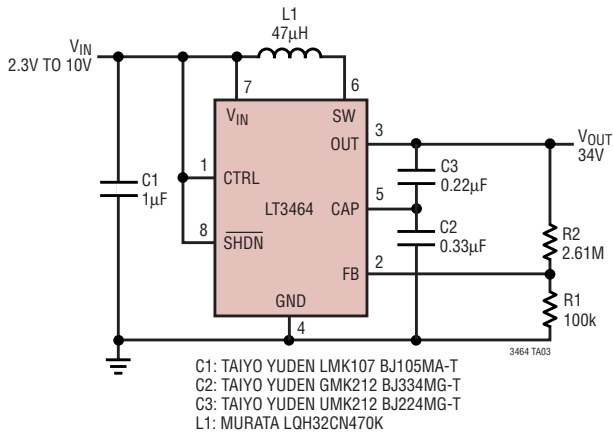

V _{IN} (V)	I _{OUT} (mA)
3.6	3.5
5.0	4.5
8.4	7.5

20V Output Converter with Output Disconnect Using an 0805 Inductor and 0603 Capacitors

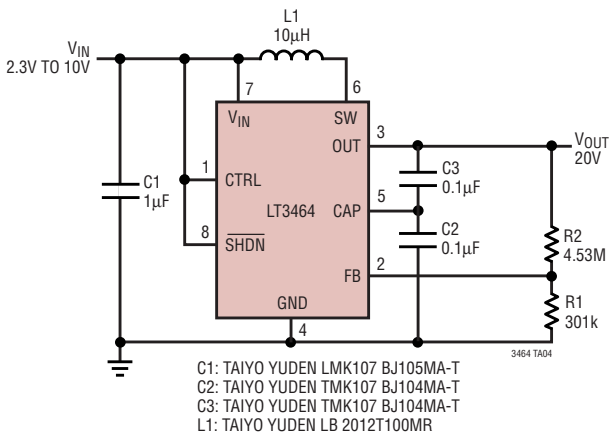

V _{IN} (V)	I _{OUT} (mA)
3.6	3.0
5.0	4.0
8.4	6.0

TYPICAL APPLICATIONS

20V Output Converter with Output Disconnect

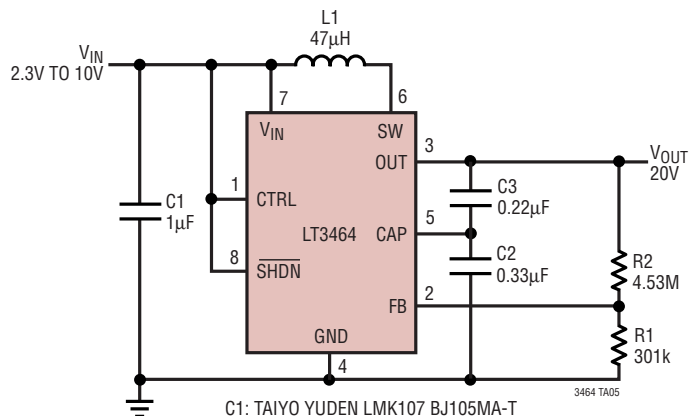

C1: TAIYO YUDEN LMK107 BJ105MA-T
 C2: TAIYO YUDEN GMK212 BJ334MG-T
 C3: TAIYO YUDEN UMK212 BJ224MG
 L1: MURATA LQH32CN470K

V _{IN} (V)	I _{OUT} (mA)
3.6	6.0
5.0	9.0
8.4	16.5

20V Output Converter with Soft Start

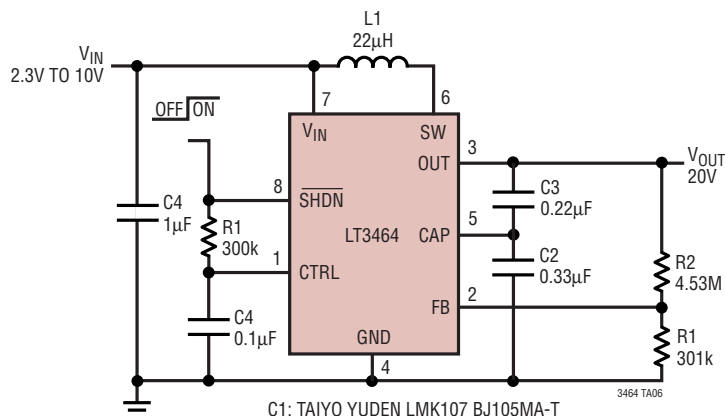

C1: TAIYO YUDEN LMK107 BJ105MA-T
 C2: TAIYO YUDEN GMK212 BJ334MG-T
 C3: TAIYO YUDEN EMK107 BJ224MA-T
 L1: MURATA LQH32CN220K

V _{IN} (V)	I _{OUT} (mA)
3.6	5.0
5.0	6.5
8.4	11.0

TYPICAL APPLICATIONS

8V Output Converter with Output Disconnect

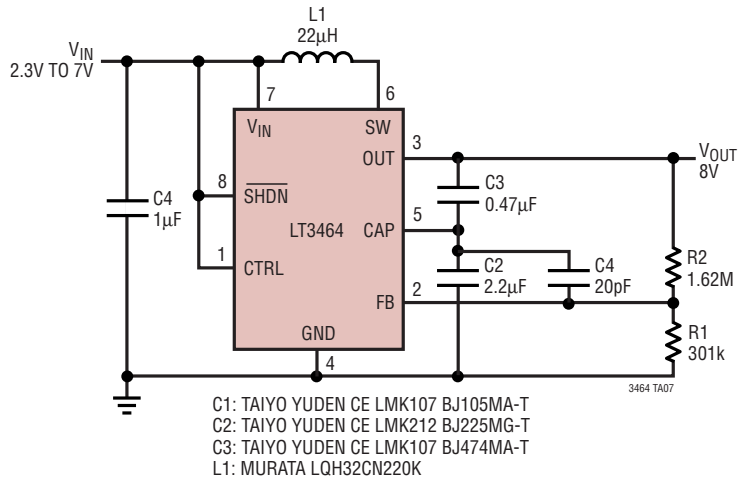

V _{IN} (V)	I _{OUT} (mA)
3.6	13.5
5.0	20

±20V Dual Output Converter with Output Disconnect

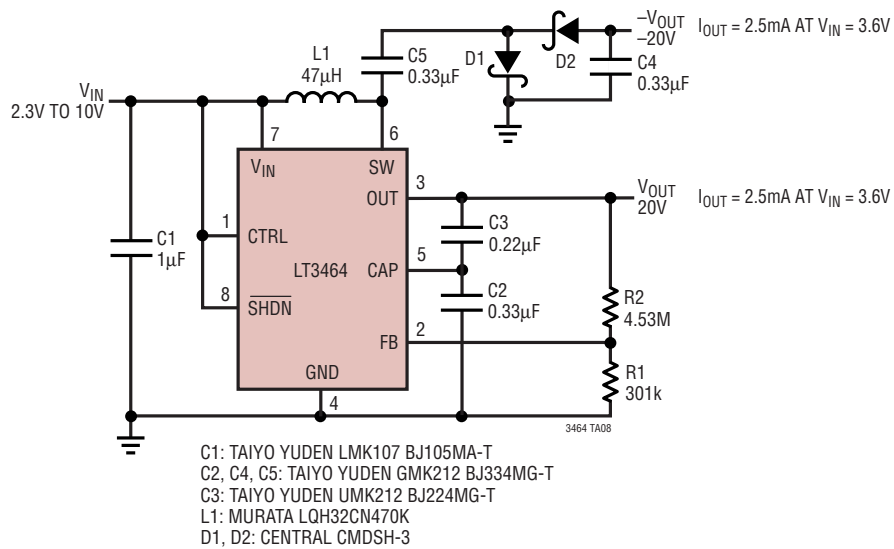

PACKAGE DESCRIPTION

TS8 Package
8-Lead Plastic TSOT-23
 (Reference LTC DWG # 05-08-1637)

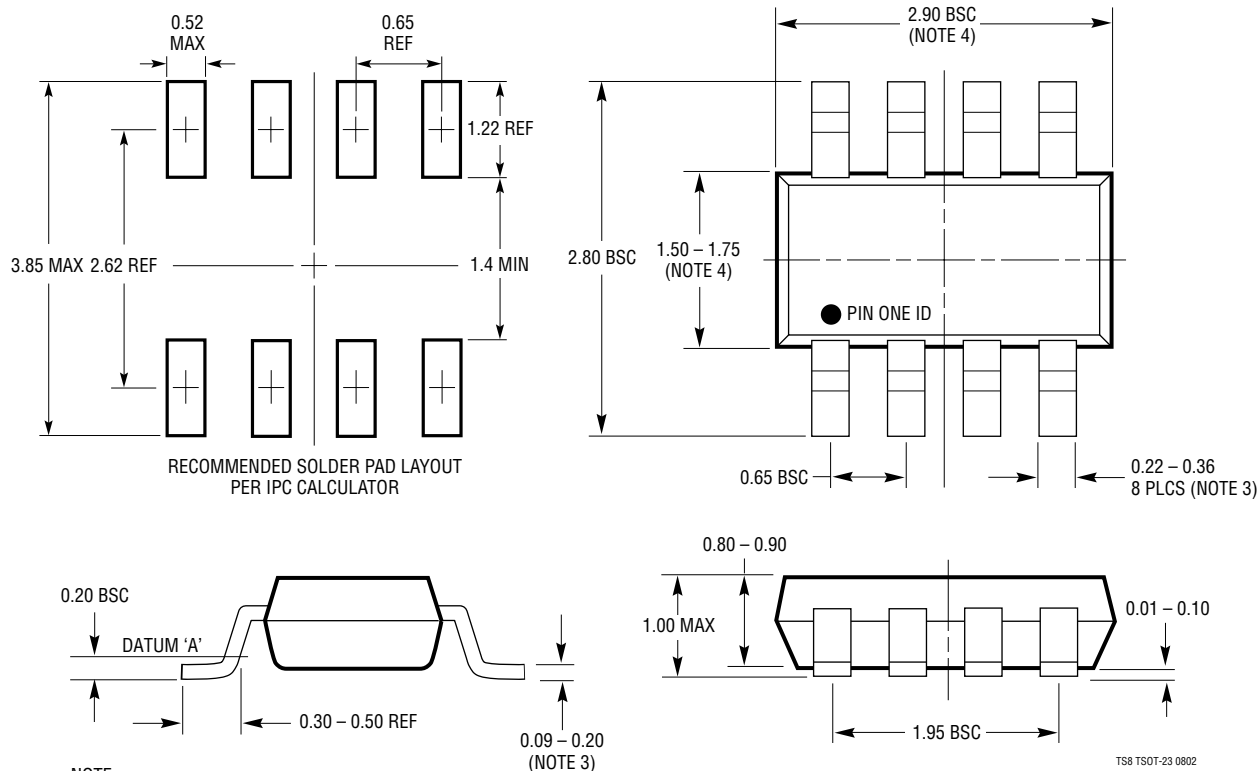

- NOTE:
1. DIMENSIONS ARE IN MILLIMETERS
 2. DRAWING NOT TO SCALE
 3. DIMENSIONS ARE INCLUSIVE OF PLATING
 4. DIMENSIONS ARE EXCLUSIVE OF MOLD FLASH AND METAL BURR
 5. MOLD FLASH SHALL NOT EXCEED 0.254mm
 6. JEDEC PACKAGE REFERENCE IS MO-193

TS8 TSOT-23 0802

TYPICAL APPLICATIONS

20V Output Converter with Variable Output Voltage and Shutdown

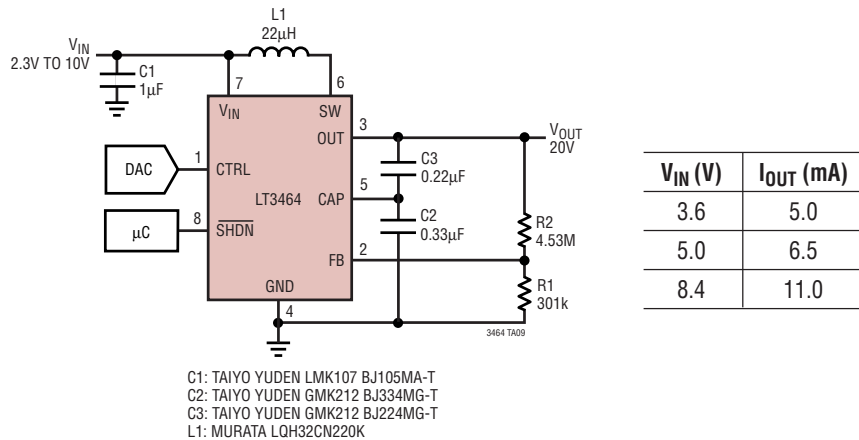

RELATED PARTS

PART NUMBER	DESCRIPTION	COMMENTS
LT1613	550mA (I _{SW}), 1.4MHz, High Efficiency Step-Up DC/DC Converter	V _{IN} = 0.9V to 10V, V _{OUT(MAX)} = 34V, I _Q = 3mA, I _{SD} = <1µA, ThinSOT Package
LT1615/ LT1615-1	300mA/80mA (I _{SW}), Constant Off-Time, High Efficiency Step-Up DC/DC Converter	V _{IN} = 1.2V to 15V, V _{OUT(MAX)} = 34V, I _Q = 20µA, I _{SD} = <1µA, ThinSOT Package
LT1618	Constant Current, Constant Voltage, 1.4MHz, High Efficiency Boost Regulator	V _{IN} = 1.6V to 18V, V _{OUT(MAX)} = 34V, I _Q = 1.8mA, I _{SD} = <1µA, MS Package, Up to 6 White LEDs
LT1932	Constant Current, 1.2MHz, High Efficiency White LED Boost Regulator	V _{IN} = 1V to 10V, V _{OUT(MAX)} = 34V, I _Q = 1.2mA, I _{SD} = <1µA, ThinSOT Package, Up to 8 White LEDs
LT1937	Constant Current, 1.2MHz, High Efficiency White LED Boost Regulator	V _{IN} = 2.5V to 10V, V _{OUT(MAX)} = 34V, I _Q = 1.9mA, I _{SD} = <1µA, SC-70, ThinSOT Packages, Up to 4 White LEDs
LT1944	Dual Output 350mA (I _{SW}), Constant Off-Time, High Efficiency Step-Up DC/DC Converter	V _{IN} = 1.2V to 15V, V _{OUT(MAX)} = 34V, I _Q = 20µA, I _{SD} = <1µA, MS Package
LT1944-1	Dual Output 150mA (I _{SW}), Constant Off-Time, High Efficiency Step-Up DC/DC Converter	V _{IN} = 1.2V to 15V, V _{OUT(MAX)} = 34V, I _Q = 20µA, I _{SD} = <1µA, MS Package
LT1945	Dual Output, ±350mA (I _{SW}), Constant Off-Time, High Efficiency Step-Up DC/DC Converter	V _{IN} = 1.2V to 15V, V _{OUT(MAX)} = ±34V, I _Q = 20µA, I _{SD} = <1µA, MS Package
LTC3200/ LTC3200-5	Low Noise, 2MHz, Regulated Charge Pump White LED Driver	V _{IN} = 2.7V to 4.5V, I _Q = 8mA, I _{SD} = <1µA, MS, ThinSOT Packages, Up to 6 White LEDs
LTC3201	Low Noise, 1.7MHz, Regulated Charge Pump White LED Driver	V _{IN} = 2.7V to 4.5V, I _Q = 6.5mA, I _{SD} = <1µA, MS Package, Up to 6 White LEDs
LTC3202	Low Noise, 1.5MHz, Regulated Charge Pump White LED Driver	V _{IN} = 2.7V to 4.5V, I _Q = 5mA, I _{SD} = <1µA, MS Package, Up to 8 White LEDs
LTC3400/ LTC3400B	600mA (I _{SW}), 1.2MHz, Synchronous Step-Up DC/DC Converter	V _{IN} = 0.85V to 5V, V _{OUT(MAX)} = 5V, I _Q = 19µA/300µA, I _{SD} = <1µA, ThinSOT Package
LTC3401	1A (I _{SW}), 3MHz, Synchronous Step-Up DC/DC Converter	V _{IN} = 0.5V to 5V, V _{OUT(MAX)} = 6V, I _Q = 38µA, I _{SD} = <1µA, MS Package
LTC3402	2A (I _{SW}), 3MHz, Synchronous Step-Up DC/DC Converter	V _{IN} = 0.5V to 5V, V _{OUT(MAX)} = 6V, I _Q = 38µA, I _{SD} = <1µA, MS Package

Looking for pricing, stock, or lifecycle information?

Click below to explore more details on WIN SOURCE:

 [View LT3464ETS8#TRMPBF on WIN SOURCE](#)

 [Linear Technology](#) Information

Optimize Your Supply Chain with WIN SOURCE Solutions

-  Global Sourcing Solution
-  Obsolete Management
-  Cost Control Management
-  Shortage Management
-  Alternative Solution
-  Excess Inventory Management