



**THE DATASHEET OF  
LT3506AEDHD#PBF**



## FEATURES

- Wide Input Voltage Range, 3.6V to 25V
- Two 1.6A Output Switching Regulators with Internal Power Switches
- Constant Switching Frequency  
 LT3506: 575kHz  
 LT3506A: 1.1MHz
- Anti-Phase Switching Reduces Ripple
- Accurate 0.8V Reference,  $\pm 1\%$
- Independent Shutdown/Soft-Start Pins
- Independent Power Good Indicators Ease Supply Sequencing
- Uses Small Inductors and Ceramic Capacitors
- Small 16-Lead Thermally Enhanced 5mm  $\times$  4mm DFN and TSSOP Surface Mount Packages

## APPLICATIONS

- Disk Drives
- DSP Power Supplies
- Wall Transformer Regulation
- Distributed Power Regulation
- DSL Modems
- Cable Modems

## DESCRIPTION

The LT<sup>®</sup>3506 is a dual current mode PWM step-down DC/DC converter with internal 2A power switches. Both converters are synchronized to a single oscillator and run with opposite phases, reducing input ripple current. The output voltages are set with external resistor dividers, and each regulator has independent shutdown and soft-start circuits. Each regulator generates a power-good signal when its output is in regulation, easing power supply sequencing and interfacing with microcontrollers and DSPs.

The LT3506 switching frequency is 575kHz and the LT3506A is 1.1MHz. These high switching frequencies allow the use of tiny inductors and capacitors, resulting in a very small dual 1.6A output solution. Constant frequency and ceramic capacitors combine to produce low, predictable output ripple voltage. With its wide input range of 3.6V to 25V, the LT3506 regulates a wide variety of power sources, from 4-cell batteries and 5V logic rails to unregulated wall transformers, lead acid batteries and distributed-power supplies. Current mode PWM architecture provides fast transient response with simple compensation components and cycle-by-cycle current limiting. Frequency foldback and thermal shutdown provide additional protection.

LT, LT, LTC, LTM, Linear Technology and the Linear logo are registered trademarks of Linear Technology Corporation. All other trademarks are the property of their respective owners.

## TYPICAL APPLICATION

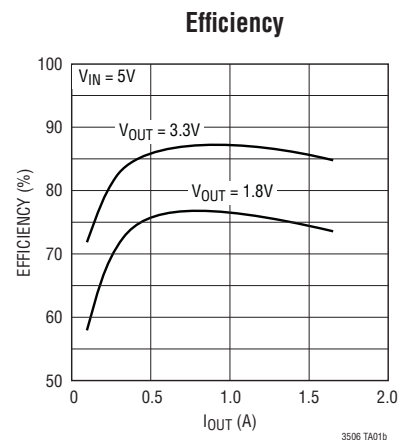
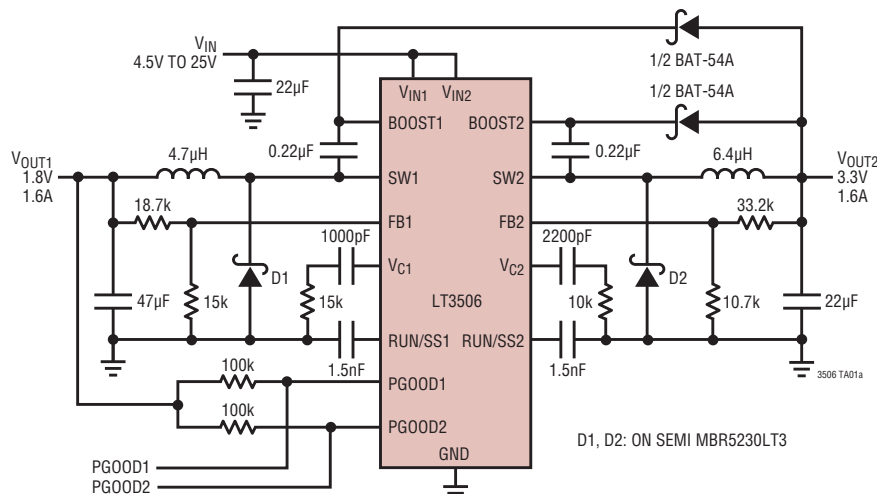

# LT3506/LT3506A

## ABSOLUTE MAXIMUM RATINGS

(Note 1)

$V_{IN}$ Voltage.....	-0.3V to 25V	Maximum Junction Temperature .....	125°C
BOOST Pin Voltage .....	50V	Operating Temperature Range (Note 2)	
BOOST Pin Above SW Pin.....	25V	E Grade .....	-40°C to 85°C
PG Pin Voltage .....	25V	I Grade .....	-40°C to 125°C
RUN/SS, FB, $V_C$ Pins.....	5.5V	Storage Temperature Range .....	-65°C to 125°C

## PIN CONFIGURATION

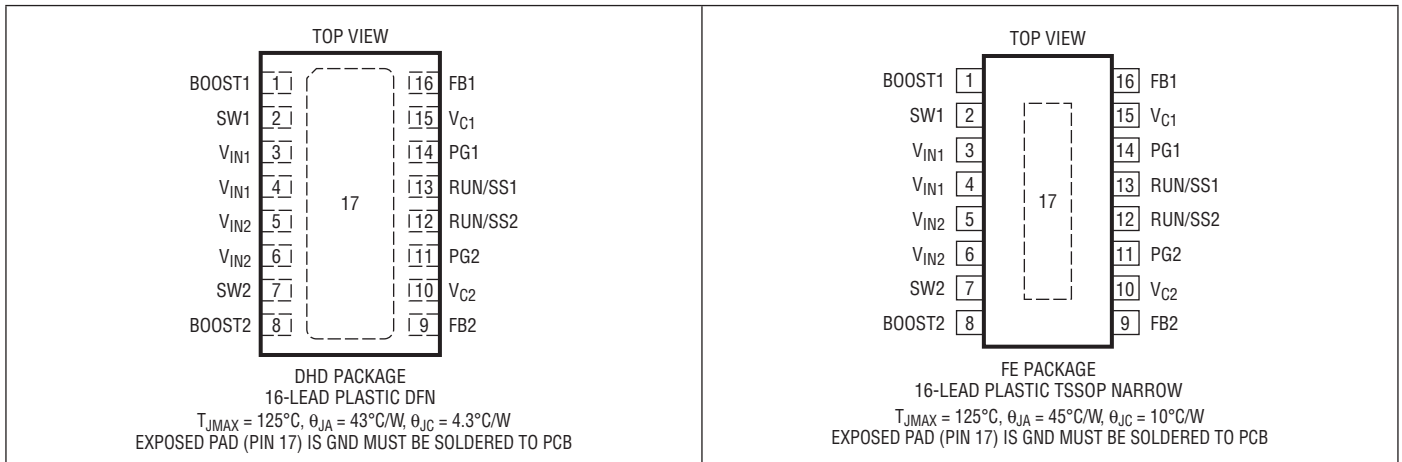

## ORDER INFORMATION

LEAD FREE FINISH	TAPE AND REEL	PART MARKING*	PACKAGE DESCRIPTION	TEMPERATURE RANGE
LT3506EDHD#PBF	LT3506EDHD#TRPBF	3506	16-Lead (5mm × 4mm) Plastic DFN	-40°C to 85°C
LT3506AEDHD#PBF	LT3506AEDHD#TRPBF	3506A	16-Lead (5mm × 4mm) Plastic DFN	-40°C to 85°C
LT3506IDHD#PBF	LT3506IDHD#TRPBF	3506	16-Lead (5mm × 4mm) Plastic DFN	-40°C to 125°C
LT3506AIDHD#PBF	LT3506AIDHD#TRPBF	3506A	16-Lead (5mm × 4mm) Plastic DFN	-40°C to 125°C
LT3506EFE#PBF	LT3506EFE#TRPBF	3506EFE	16-Lead Plastic TSSOP Narrow	-40°C to 85°C
LT3506AEFE#PBF	LT3506AEFE#TRPBF	3506AEFE	16-Lead Plastic TSSOP Narrow	-40°C to 85°C
LT3506IFE#PBF	LT3506IFE#TRPBF	3506IFE	16-Lead Plastic TSSOP Narrow	-40°C to 125°C
LT3506AIFE#PBF	LT3506AIFE#TRPBF	3506AIFE	16-Lead Plastic TSSOP Narrow	-40°C to 125°C
LEAD BASED FINISH	TAPE AND REEL	PART MARKING*	PACKAGE DESCRIPTION	TEMPERATURE RANGE
LT3506EDHD	LT3506EDHD#TR	3506	16-Lead (5mm × 4mm) Plastic DFN	-40°C to 85°C
LT3506AEDHD	LT3506AEDHD#TR	3506A	16-Lead (5mm × 4mm) Plastic DFN	-40°C to 85°C
LT3506IDHD	LT3506IDHD#TR	3506	16-Lead (5mm × 4mm) Plastic DFN	-40°C to 125°C
LT3506AIDHD	LT3506AIDHD#TR	3506A	16-Lead (5mm × 4mm) Plastic DFN	-40°C to 125°C
LT3506EFE	LT3506EFE#TR	3506EFE	16-Lead Plastic TSSOP Narrow	-40°C to 85°C
LT3506AEFE	LT3506AEFE#TR	3506AEFE	16-Lead Plastic TSSOP Narrow	-40°C to 85°C
LT3506IFE	LT3506IFE#TR	3506IFE	16-Lead Plastic TSSOP Narrow	-40°C to 125°C
LT3506AIFE	LT3506AIFE#TR	3506AIFE	16-Lead Plastic TSSOP Narrow	-40°C to 125°C

Consult LTC Marketing for parts specified with wider operating temperature ranges. \*The temperature grade is identified by a label on the shipping container.

For more information on lead free part marking, go to: <http://www.linear.com/leadfree/>

For more information on tape and reel specifications, go to: <http://www.linear.com/tapeandreel/>

3506afc

**ELECTRICAL CHARACTERISTICS** The ● denotes the specifications which apply over the full operating temperature range, otherwise specifications are at  $T_A = 25^\circ\text{C}$ ,  $V_{IN} = 5\text{V}$ ,  $V_{BOOST} = 8\text{V}$ , unless otherwise noted. (Note 2)

SYMBOL	PARAMETER	CONDITIONS	MIN	TYP	MAX	UNITS	
$V_{IN(MIN)}$	Undervoltage Lockout		●	3.4	3.6	V	
$I_{INQ}$	Quiescent Current	Not Switching		3.8	4.8	mA	
$I_{INSD}$	Shutdown Current	$V_{RUNSS} = 0\text{V}$		30	45	$\mu\text{A}$	
$V_{FB}$	Feedback Voltage	$-40^\circ\text{C}$ to $85^\circ\text{C}$ , DHD $-40^\circ\text{C}$ to $85^\circ\text{C}$ , EFE $-40^\circ\text{C}$ to $125^\circ\text{C}$ , IFE	● ● ●	792 784 784	800 800 800	808 816 816	mV mV mV
$I_{FB}$	FB Pin Bias Current	$V_{FB} = 800\text{mV}$ , $V_C = 0.4\text{V}$	●	40	100	nA	
$V_{FB(REG)}$	Reference Line Regulation	$V_{IN} = 5\text{V}$ to $25\text{V}$		0.005		%/V	
$g_{mEA}$	Error Amp GM			350		$\mu\text{Mhos}$	
$A_V$	Error Amp Voltage Gain			400			
$I_{VC}$	$V_C$ Source Current $V_C$ Sink Current	$V_{FB} = 0.6\text{V}$ , $V_C = 0\text{V}$ $V_{FB} = 1.2\text{V}$ , $V_C = 1100\text{mV}$		30 30		$\mu\text{A}$ $\mu\text{A}$	
$V_{VC(THRESH)}$	$V_C$ Switching Threshold			0.7		V	
$V_{VC(CLAMP)}$	$V_C$ Clamp Voltage			1.9		V	
$f_{SW}$	Switching Frequency	LT3506 LT3506A	500 1	575 1.1	650 1.2	kHz MHz	
	Switching Phase	(Note 5)		180		Deg	
DC	Maximum Duty Cycle	LT3506 LT3506A	89 78	93 88		% %	
$V_{FB(SWTHRESH)}$	Frequency Shift Threshold on FB			0.4		V	
$f_{FOLD}$	Foldback Frequency	$V_{FB} = 0\text{V}$		170		kHz	
$I_{SW}$	Switch Current Limit	(Note 3)	2.0	2.6	3.6	A	
$V_{SW(SAT)}$	Switch $V_{CESAT}$ (Note 4)	$I_{SW} = 1\text{A}$		210		mV	
$I_{LSW}$	Switch Leakage Current				10	$\mu\text{A}$	
$V_{BOOST(MIN)}$	Minimum Boost Voltage Above Switch	$I_{SW} = 1\text{A}$		1.5	2.5	V	
$I_{BOOST}$	BOOST Pin Current	$I_{SW} = 1\text{A}$		20	30	mA	
$I_{RUN/SS}$	RUN/SS Current			2.1		$\mu\text{A}$	
$V_{RUN/SS(THRESH)}$	RUN/SS Threshold		0.3	0.8		V	
$V_{FB(PGTHRESH)}$	$V_{FB}$ PG Threshold	$V_{FB}$ Rising		720		mV	
$V_{PG(LOW)}$	PG Voltage Output Low	$V_{FB} = 640\text{mV}$ , $I_{PG} = 250\mu\text{A}$		0.22	0.4	V	
$I_{LPG}$	PG Pin Leakage	$V_{PG} = 2\text{V}$		0.1	1	$\mu\text{A}$	

**Note 1:** Stresses beyond those listed under Absolute Maximum Ratings may cause permanent damage to the device. Exposure to any Absolute Maximum Rating condition for extended periods may affect device reliability and lifetime.

**Note 2:** The LT3506E/LT3506AE are guaranteed to meet performance specifications from  $0^\circ\text{C}$  to  $85^\circ\text{C}$ . Specifications over the  $-40^\circ\text{C}$  to  $85^\circ\text{C}$  operating temperature range are assured by design, characterization and

correlation with statistical process controls. The LT3506I/LT3506AI are guaranteed and tested over the full  $-40^\circ\text{C}$  to  $125^\circ\text{C}$  operating temperature range.

**Note 3:** Current limit is guaranteed by design and/or correlation to static test. Slope compensation reduces current limit at high duty cycle.

**Note 4:** Switch  $V_{CESAT}$  guaranteed by design.

**Note 5:** Switching phase is guaranteed by design.

## TYPICAL PERFORMANCE CHARACTERISTICS

**Efficiency,  $V_{OUT} = 1.8V$  (LT3506A)**

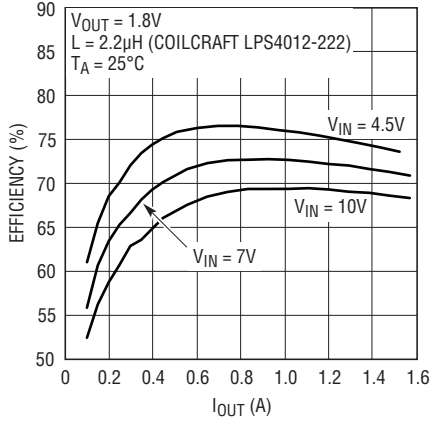

3506 G01

**Efficiency,  $V_{OUT} = 3.3V$  (LT3506)**

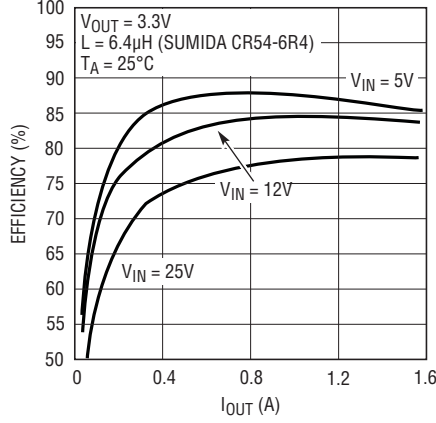

3506 G02

**Efficiency,  $V_{OUT} = 5V$  (LT3506)**

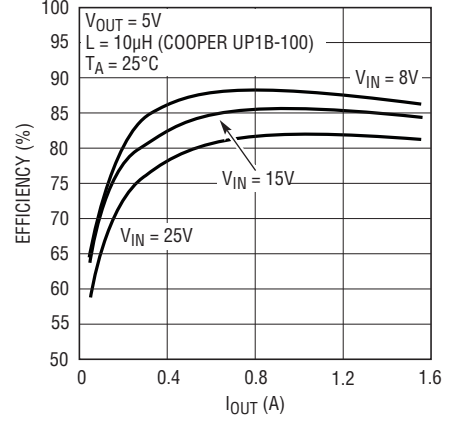

3506 G03

**Maximum Load Current,  $V_{OUT} = 1.8V$  (LT3506A)**

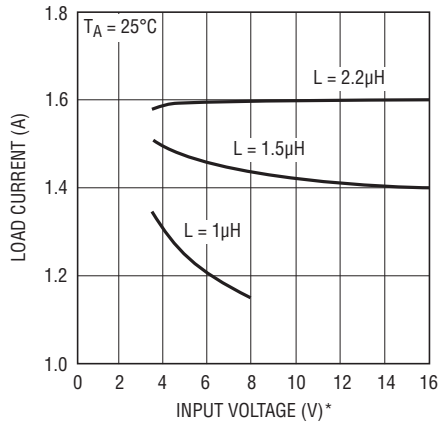

3506 G04

**Maximum Load Current,  $V_{OUT} = 3.3V$  (LT3506A)**

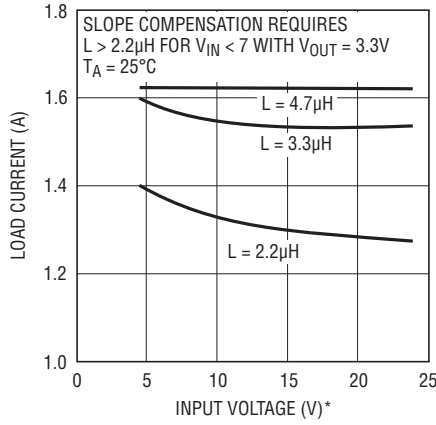

3506 G05

**Switch  $V_{CESAT}$**

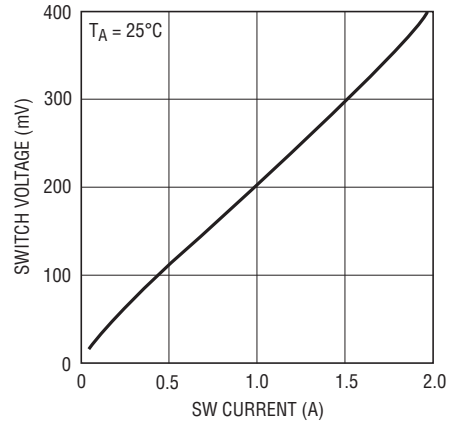

3506 G06

**Boost Pin Current**

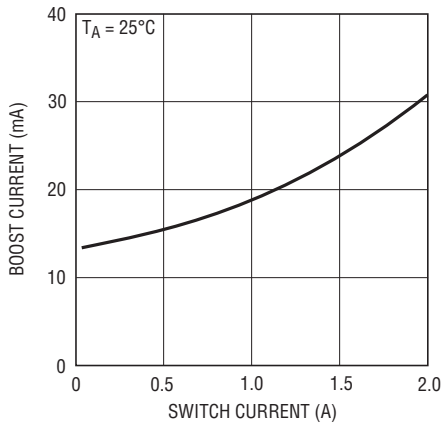

3506 G07

**Current Limit vs Duty Cycle**

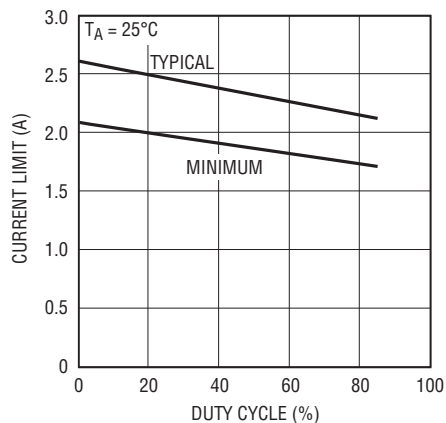

3506 G08

## TYPICAL PERFORMANCE CHARACTERISTICS

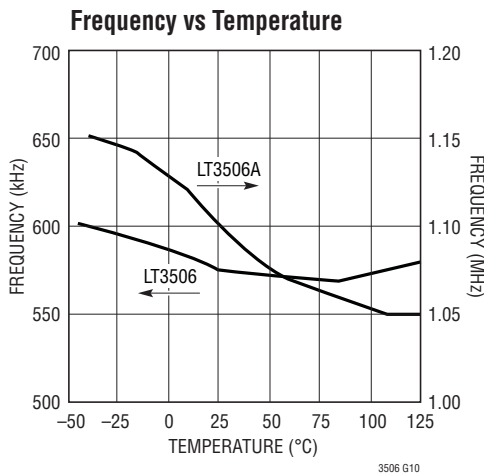

3506 G10

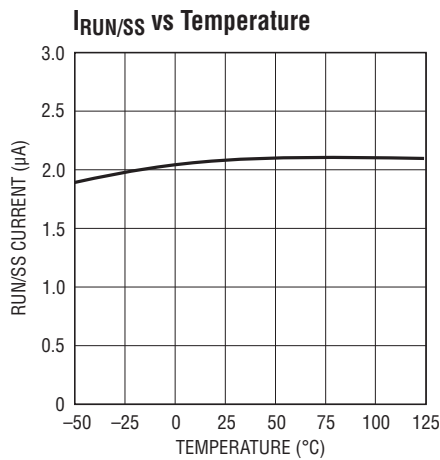

3506 G12

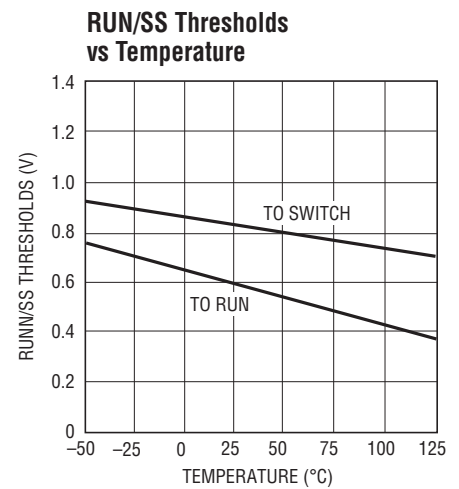

3506 G13

## PIN FUNCTIONS

**BOOST1 (Pin 1), BOOST2 (Pin 8):** The BOOST pins are used to provide drive voltages, higher than the input voltage, to the internal bipolar NPN power switches. Tie through a diode from  $V_{OUT}$  or from  $V_{IN}$ .

**SW1 (Pin 2), SW2 (Pin 7):** The SW pins are the outputs of the internal power switches. Connect these pins to the inductors, catch diodes and boost capacitors.

**$V_{IN1}$  (Pins 3, 4):** The  $V_{IN1}$  pins supply current to the LT3506's internal regulator and to the internal power switch connected to SW1. These pins must be locally bypassed.

**$V_{IN2}$  (Pins 5, 6):** The  $V_{IN2}$  pins supply current to the internal power switch connected to SW2 and must be locally bypassed. Connect these pins directly to  $V_{IN1}$  unless power for channel 2 is coming from a different source.

**RUN/SS1 (Pin 13), RUN/SS2 (Pin 12):** The RUN/SS pins are used to shut down the individual switching regulators and the internal bias circuits. They also provide a soft-start function. To shut down either regulator, pull the RUN/SS pin to ground with an open drain or collector. Tie a capacitor from these pins to ground to limit switch current during start-up. If neither feature is used, leave these pins unconnected.

**PG1 (Pin 14), PG2 (Pin 11):** The Power Good pins are the open collector outputs of an internal comparator. PG remains low until the FB pin is within 10% of the final regulation voltage. As well as indicating output regulation, the PG pins can be used to sequence the two switching regulators. These pins can be left unconnected. The PG outputs are valid when  $V_{IN}$  is greater than 3.4V and either of the RUN/SS pins is high. The PG comparators are disabled in shutdown.

**$V_{C1}$  (Pin 15),  $V_{C2}$  (Pin 10):** The  $V_C$  pins are the outputs of the internal error amps. The voltages on these pins control the peak switch currents. These pins are normally used to compensate the control loops, but can also be used to override the loops. Pull these pins to ground with an open drain to shut down each switching regulator.

**FB1 (Pin 16), FB2 (Pin 9):** The LT3506 regulates each feedback pin to 800mV. Connect the feedback resistor divider taps to these pins.

**Exposed Pad (Pin 17):** The Exposed Pad of the package provides both electrical contact to ground and good thermal contact to the printed circuit board. The Exposed Pad must be soldered to the circuit board for proper operation.

**BLOCK DIAGRAM**

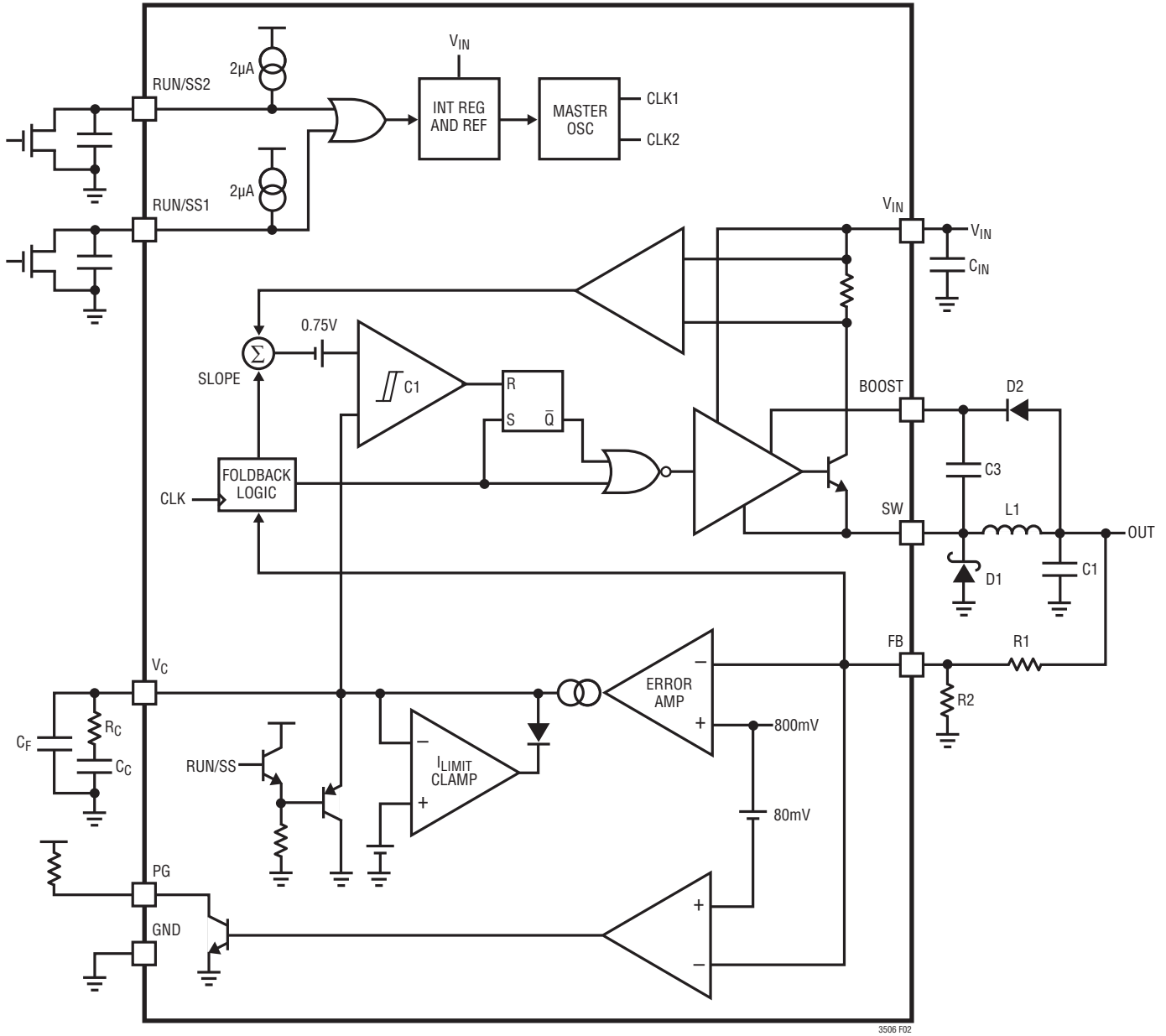

Figure 2. Block Diagram of the LT3506 with Associated External Components (1 of 2 Regulators Shown)

## OPERATION (Refer to the Block Diagram)

The LT3506 is a dual, constant frequency, current mode buck regulator with internal 2A power switches. The two regulators share common circuitry including voltage reference and oscillator. In addition, the analog blocks on both regulators share the  $V_{IN1}$  supply voltage, but are otherwise independent. This section describes the operation of the LT3506.

If the RUN/SS (run/soft-start) pins are both tied to ground, the LT3506 is shut down and draws 30 $\mu$ A from  $V_{IN1}$ . Internal 2 $\mu$ A current sources charge external soft-start capacitors, generating voltage ramps at these pins. If either RUN/SS pin exceeds 0.6V, the internal bias circuits turn on, including the internal regulator, 800mV reference and 575kHz master oscillator. In this state, the LT3506 draws 3.8mA from  $V_{IN1}$ , whether one or both RUN/SS pins are high. Neither switching regulator will begin to operate until its RUN/SS pin reaches  $\sim$ 0.8V. The master oscillator generates two clock signals of opposite phase.

The two switchers are current mode, step-down regulators. This means that instead of directly modulating the duty cycle of the power switch, the feedback loop controls the peak current in the switch during each cycle. This current mode control improves loop dynamics and provides cycle-by-cycle current limit.

The Block Diagram in Figure 2 shows only one of the two switching regulators. A pulse from the slave oscillator sets the RS flip-flop and turns on the internal NPN bipolar power switch. Current in the switch and the external inductor begins to increase. When this current exceeds a level determined by the voltage at  $V_C$ , current comparator C1 resets the flip-flop, turning off the switch. The current in

the inductor flows through the external Schottky diode, and begins to decrease. The cycle begins again at the next pulse from the oscillator. In this way the voltage on the  $V_C$  pin controls the current through the inductor to the output. The internal error amplifier regulates the output voltage by continually adjusting the  $V_C$  pin voltage.

The threshold for switching on the  $V_C$  pin is 0.75V, and an active clamp of 1.9V limits the output current. The  $V_C$  pin is also clamped to the RUN/SS pin voltage. As the internal current source charges the external soft-start capacitor, the current limit increases slowly. Each switcher contains an independent oscillator. This slave oscillator is normally synchronized to the master oscillator. However, during start-up, short-circuit or overload conditions, the FB pin voltage will be near zero and an internal comparator gates the master oscillator clock signal. This allows the slave oscillator to run the regulator at a lower frequency. This frequency foldback behavior helps to limit switch current and power dissipation under fault conditions.

The switch driver operates from either the input or from the BOOST pin. An external capacitor and diode are used to generate a voltage at the BOOST pin that is higher than the input supply. This allows the driver to fully saturate the internal bipolar NPN power switch for efficient operation.

A power good comparator trips when the FB pin is at 90% of its regulated value. The PG output is an open collector transistor that is off when the output is in regulation, allowing an external resistor to pull the PG pin high. Power good is valid when the LT3506 is enabled (either RUN/SS pin is high) and  $V_{IN}$  is greater than  $\sim$ 3.4V.

## APPLICATIONS INFORMATION

### FB Resistor Network

The output voltage is programmed with a resistor divider between the output and the FB pin. Choose the 1% resistors according to:

$$R1 = R2(V_{OUT}/0.8 - 1)$$

The parallel combination of R1 and R2 should be 10k or less to avoid bias current errors. Reference designators refer to the Block Diagram in Figure 2.

### Input Voltage Range

The minimum input voltage is determined by either the LT3506's minimum operating voltage of ~3.6V, or by its maximum duty cycle. The duty cycle is the fraction of time that the internal switch is on and is determined by the input and output voltages:

$$DC = (V_{OUT} + V_D)/(V_{IN} - V_{SW} + V_D)$$

where  $V_D$  is the forward voltage drop of the catch diode (~0.4V) and  $V_{SW}$  is the voltage drop of the internal switch (~0.3V at maximum load). This leads to a minimum input voltage of:

$$V_{IN(MIN)} = (V_{OUT} + V_D)/DC_{MAX} - V_D + V_{SW}$$

with  $DC_{MAX} = 0.89$  (0.78 for the LT3506A).

A more detailed analysis includes inductor loss and the dependence of the diode and switch drop on operating current. A common application where the maximum duty cycle limits the input voltage range is the conversion of 5V to 3.3V. The maximum load current that the LT3506 can deliver at 3.3V depends on the accuracy of the 5V input supply. With a low loss inductor (DCR less than 80m $\Omega$ ), the LT3506 can deliver 1.2A for  $V_{IN} > 4.7V$  and 1.6A for  $V_{IN} > 4.85V$ . The maximum input voltage is determined by the absolute maximum ratings of the  $V_{IN}$  and BOOST pins and by the minimum duty cycle  $DC_{MIN} = 0.08$  (0.15 for the LT3506A):

$$V_{IN(MAX)} = (V_{OUT} + V_D)/DC_{MIN} - V_D + V_{SW}$$

This limits the maximum input voltage to ~21V with  $V_{OUT} = 1.2V$  and ~15V with  $V_{OUT} = 0.8V$ . For the LT3506A the

maximum input voltage is ~8V with  $V_{OUT} = 0.8V$ . Note that this is a restriction on the operating input voltage; the circuit will tolerate transient inputs up to the absolute maximum rating.

### Inductor Selection and Maximum Output Current

A good first choice for the inductor value is:

$$L = 2 \cdot (V_{OUT} + V_D) \text{ for the LT3506}$$

$$L = (V_{OUT} + V_D) \text{ for the LT3506A}$$

where  $V_D$  is the voltage drop of the catch diode (~0.4V) and L is in  $\mu H$ . With this value the maximum load current will be ~1.6A, independent of input voltage. The inductor's RMS current rating must be greater than your maximum load current and its saturation current should be about 30% higher. To keep efficiency high, the series resistance (DCR) should be less than 0.1 $\Omega$ . Table 1 lists several vendors and types that are suitable. Of course, such a simple design guide will not always result in the optimum inductor for your application. A larger value provides a slightly higher maximum load current, and will reduce the output voltage ripple. If your load is lower than 1.6A, then you can decrease the value of the inductor and operate with higher ripple current. This allows you to use a physically smaller inductor, or one with a lower DCR resulting in higher efficiency. Be aware that if the inductance differs from the simple rule above, then the maximum load current will depend on input voltage. There are several graphs in the Typical Performance Characteristics section of this data sheet that show the maximum load current as a function of input voltage and inductor value for several popular output voltages. Also, low inductance may result in discontinuous mode operation, which may be acceptable, but further reduces maximum load current. For details of maximum output current and discontinuous mode operation, see Linear Technology Application Note 44. Finally, for duty cycles greater than 50% ( $V_{OUT}/V_{IN} < 0.5$ ), there is a minimum inductance required to avoid subharmonic oscillations. See Application Note 19 for detailed information on subharmonic oscillations. The following discussion assumes continuous inductor current.

## APPLICATIONS INFORMATION

The current in the inductor is a triangle wave with an average value equal to the load current. The peak switch current is equal to the output current plus half the peak-to-peak inductor ripple current. The LT3506 limits its switch current in order to protect itself and the system from overload faults. Therefore, the maximum output current that the LT3506 will deliver depends on the current limit, the inductor value and the input and output voltages. L is chosen based on output current requirements, output voltage ripple requirements, size restrictions and efficiency goals. When the switch is off, the inductor sees the output voltage plus the catch diode drop. This gives the peak-to-peak ripple current in the inductor:

$$\Delta I_L = (1 - DC)(V_{OUT} + V_D)/(L \cdot f)$$

where f is the switching frequency of the LT3506 and L is the value of the inductor. The peak inductor and switch current is

$$I_{SWPK} = I_{LPK} = I_{OUT} + \Delta I_L/2.$$

To maintain output regulation, this peak current must be less than the LT3506's switch current limit  $I_{LIM}$ .  $I_{LIM}$  is at least 2A at low duty cycle and decreases linearly to 1.7A at DC = 0.8. The maximum output current is a function of the chosen inductor value:

$$I_{OUT(MAX)} = I_{LIM} - \Delta I_L/2 = 2A \cdot (1 - 0.21 \cdot DC) - \Delta I_L/2$$

If the inductor value is chosen so that the ripple current is small, then the available output current will be near the switch current limit. One approach to choosing the inductor is to start with the simple rule given above, look at the available inductors, and choose one to meet cost or space goals. Then use these equations to check that the LT3506 will be able to deliver the required output current. Note again that these equations assume that the inductor current is continuous. Discontinuous operation occurs when  $I_{OUT}$  is less than  $\Delta I_L/2$  as calculated above.

**Table 1. Inductors**

PART NUMBER	VALUE (μH)	ISAT (A)	DCR (Ω)	HEIGHT (mm)
<b>Sumida</b>				
CR43-3R3	3.3	1.44	0.086	3.5
CR43-4R7	4.7	1.15	0.109	3.5
CDC5d23-2R2	2.2	2.16	0.030	2.5
CDRH5D28-2R6	2.6	2.60	0.013	3.0
CDRH6D26-5R6	5.6	2.00	0.027	2.8
CDH113-100	10	2.00	0.047	3.7
<b>Coilcraft</b>				
DO1606T-152	1.5	2.10	0.060	2.0
DO1606T-222	2.2	1.70	0.070	2.0
DO1608C-332	3.3	2.00	0.080	2.9
DO1608C-472	4.7	1.50	0.090	2.9
DO1813P-682HC	6.8	2.20	0.080	5.0
<b>Cooper</b>				
SD414-2R2	2.2	2.73	0.061	1.35
SD414-6R8	6.8	1.64	0.135	1.35
UP1B-100	10	1.90	0.111	5.0
<b>Toko</b>				
(D62F)847FY-2R4M	2.4	2.5	0.037	2.7
(D73LF)817FY-2R2M	2.2	2.7	0.03	3.0

### Input Capacitor Selection

Bypass the input of the LT3506 circuit with a 4.7μF or higher ceramic capacitor of X7R or X5R type. A lower value or a less expensive Y5V type can be used if there is additional bypassing provided by bulk electrolytic or tantalum capacitors. The following paragraphs describe the input capacitor considerations in more detail. Step-down regulators draw current from the input supply in pulses with very fast rise and fall times. The input capacitor is required to reduce the resulting voltage ripple at the LT3506 and to force this very high frequency switching current into a tight local loop, minimizing EMI. The input capaci-

## APPLICATIONS INFORMATION

tor must have low impedance at the switching frequency to do this effectively, and it must have an adequate ripple current rating. With two switchers operating at the same frequency but with different phases and duty cycles, calculating the input capacitor RMS current is not simple. However, a conservative value is the RMS input current for the channel that is delivering most power ( $V_{OUT} \cdot I_{OUT}$ ). This is given by:

$$I_{INRMS} = I_{OUT} \frac{\sqrt{V_{OUT} \cdot (V_{IN} - V_{OUT})}}{V_{IN}} < \frac{I_{OUT}}{2}$$

and is largest when  $V_{IN} = 2V_{OUT}$  (50% duty cycle). As the second, lower power channel draws input current, the input capacitor's RMS current actually decreases as the out-of-phase current cancels the current drawn by the higher power channel. Considering that the maximum load current from a single channel is ~1.6A, RMS ripple current will always be less than 0.8A.

The high frequency of the LT3506 reduces the energy storage requirements of the input capacitor, so that the capacitance required is less than 22 $\mu$ F (less than 10 $\mu$ F for the LT3506A). The combination of small size and low impedance (low equivalent series resistance or ESR) of ceramic capacitors makes them the preferred choice. The low ESR results in very low voltage ripple and the capacitors can handle plenty of ripple current. They are also comparatively robust and can be used in this application at their rated voltage. X5R and X7R types are stable over temperature and applied voltage, and give dependable service. Other types (Y5V and Z5U) have very large temperature and voltage coefficients of capacitance, so they may have only a small fraction of their nominal capacitance in your application. While they will still handle the RMS ripple current, the input voltage ripple may become fairly large, and the ripple current may end up flowing from your input supply or from other bypass capacitors in your system, as opposed to being fully sourced from the local input capacitor.

An alternative to a high value ceramic capacitor is a lower value along with a larger electrolytic capacitor, for example a 1 $\mu$ F ceramic capacitor in parallel with a low ESR tantalum capacitor. For the electrolytic capacitor, a value larger than

22 $\mu$ F (10 $\mu$ F for the LT3506A) will be required to meet the ESR and ripple current requirements. Because the input capacitor is likely to see high surge currents when the input source is applied, tantalum capacitors should be surge rated. The manufacturer may also recommend operation below the rated voltage of the capacitor. Be sure to place the 1 $\mu$ F ceramic as close as possible to the  $V_{IN}$  and GND pins on the IC for optimal noise immunity.

A final caution is in order regarding the use of ceramic capacitors at the input. A ceramic input capacitor can combine with stray inductance to form a resonant tank circuit. If power is applied quickly (for example by plugging the circuit into a live power source) this tank can ring, doubling the input voltage and damaging the LT3506. The solution is to either clamp the input voltage or dampen the tank circuit by adding a lossy capacitor in parallel with the ceramic capacitor. For details, see Application Note 88.

### Output Capacitor Selection

The output capacitor filters the inductor current to generate an output with low voltage ripple. It also stores energy in order satisfy transient loads and to stabilize the LT3506's control loop. Because the LT3506 operates at a high frequency, you don't need much output capacitance. Also, the current mode control loop doesn't require the presence of output capacitor series resistance (ESR). For these reasons, you are free to use ceramic capacitors to achieve very low output ripple and small circuit size.

Estimate output ripple with the following equations:

$$V_{RIPPLE} = \Delta I_L / (8 \cdot f \cdot C_{OUT}) \text{ for ceramic capacitors}$$

$$V_{RIPPLE} = \Delta I_L \cdot ESR \text{ for electrolytic capacitors (tantalum and aluminum)}$$

where  $\Delta I_L$  is the peak-to-peak ripple current in the inductor. The RMS content of this ripple is very low, and the RMS current rating of the output capacitor is usually not of concern.

Another constraint on the output capacitor is that it must have greater energy storage than the inductor; if the stored energy in the inductor is transferred to the output, you would like the resulting voltage step to be small compared

## APPLICATIONS INFORMATION

to the regulation voltage. For a 5% overshoot, this requirement becomes

$$C_{OUT} > 10L(I_{LIM}/V_{OUT})^2.$$

Finally, there must be enough capacitance for good transient performance. The last equation gives a good starting point. Alternatively, you can start with one of the designs in this data sheet and experiment to get the desired performance. This topic is covered more thoroughly in the section on loop compensation.

For 5V and 3.3V outputs with greater than 1A output, a 22μF 6.3V ceramic capacitor (X5R or X7R) at the output results in very low output voltage ripple and good transient response. For lower voltages, 22μF is adequate but increasing C<sub>OUT</sub> will improve transient performance. For the LT3506A, 10μF of output capacitance is sufficient at V<sub>OUT</sub> between 3.3V and 5V. Other types and values can be used. The following discusses tradeoffs in output ripple and transient performance.

The high performance (low ESR), small size and robustness of ceramic capacitors make them the preferred type for LT3506 applications. However, all ceramic capacitors are not the same. As mentioned above, many of the higher value capacitors use poor dielectrics with high temperature and voltage coefficients. In particular, Y5V and Z5U types lose a large fraction of their capacitance with applied voltage and temperature extremes. Because the loop stability and transient response depend on the value of C<sub>OUT</sub>, you may not be able to tolerate this loss. Use X7R and X5R types.

You can also use electrolytic capacitors. The ESRs of most aluminum electrolytics are too large to deliver low output ripple. Tantalum and newer, lower ESR organic electrolytic capacitors intended for power supply use are suitable, and the manufacturers will specify the ESR. The choice of capacitor value will be based on the ESR required for low ripple. Because the volume of the capacitor determines

its ESR, both the size and the value will be larger than a ceramic capacitor that would give similar ripple performance. One benefit is that the larger capacitance may give better transient response for large changes in load current. Table 2 lists several capacitor vendors.

**Table 2. Low-ESR Surface Mount Capacitors**

VENDOR	TYPE	SERIES
Taiyo-Yuden	Ceramic	
AVX	Ceramic Tantalum	TPS
Kemet	Tantalum Tantalum Organic Aluminum Organic	T491, T494, T495, T520  A700
Sanyo	Tantalum or Aluminum Organic	POSCAP
Panasonic	Aluminum Organic	SP CAP
TDK	Ceramic	

### Catch Diode

The catch diode (D1 in Figure 2) must have a reverse voltage rating greater than the maximum input voltage. The average current of the catch diode is given by:

$$I_{DAVE} = I_{OUT} (1 - DC_{MIN})$$

A Schottky diode with a 1A average forward current rating will suffice for most applications. The ON Semiconductor MBRM120LT3 (20V) and MBRM130LT3 (30V) are good choices; they have a tiny package with good thermal properties. Many vendors have suitable surface mount versions of the 1N5817 (20V) and 1N5818 (30V) 1A Schottky diodes such as the Microsemi UPS120.

Applications with large step down ratios and high output currents may have more than 1A of average diode current. The ON Semiconductor MBRS230LT3 or International Rectifier 20BQ030 (both 2A, 30V) would be good choices.

## APPLICATIONS INFORMATION

### BOOST Pin Considerations

The capacitor and diode tied to the BOOST pin generate a voltage that is higher than the input voltage. In most cases a 0.1µF capacitor and fast switching diode (such as the CMDSH-3 or FMMD914) will work well. Figure 3 shows three ways to arrange the boost circuit. The BOOST pin must be more than 2.5V above the SW pin for full efficiency. For outputs of 3.3V and higher the standard circuit (Figure 3a) is best. For outputs between 2.8V and 3.3V, use a small Schottky diode (such as the BAT-54). For lower output voltages the boost diode can be tied to the input (Figure 3b). The circuit in Figure 3a is more efficient because the BOOST pin current comes from a lower voltage source. Finally, as shown in Figure 3c, the anode of the boost diode can be tied to another source that is at least 3V. For example, if you are generating 3.3V and

1.8V and the 3.3V is on whenever the 1.8V is on, the 1.8V boost diode can be connected to the 3.3V output. In any case, you must also be sure that the maximum voltage at the BOOST pin is less than the maximum specified in the Absolute Maximum Ratings section.

The boost circuit can also run directly from a DC voltage that is higher than the input voltage by more than 3V, as in Figure 3d. The diode is used to prevent damage to the LT3506 in case  $V_{INB}$  is held low while  $V_{IN}$  is present. The circuit saves several components (both BOOST pins can be tied to D2). However, efficiency may be lower and dissipation in the LT3506 may be higher. Also, if  $V_{INB}$  is absent, the LT3506 will still attempt to regulate the output, but will do so with very low efficiency and high dissipation because the switch will not be able to saturate, dropping 1.5V to 2V in conduction.

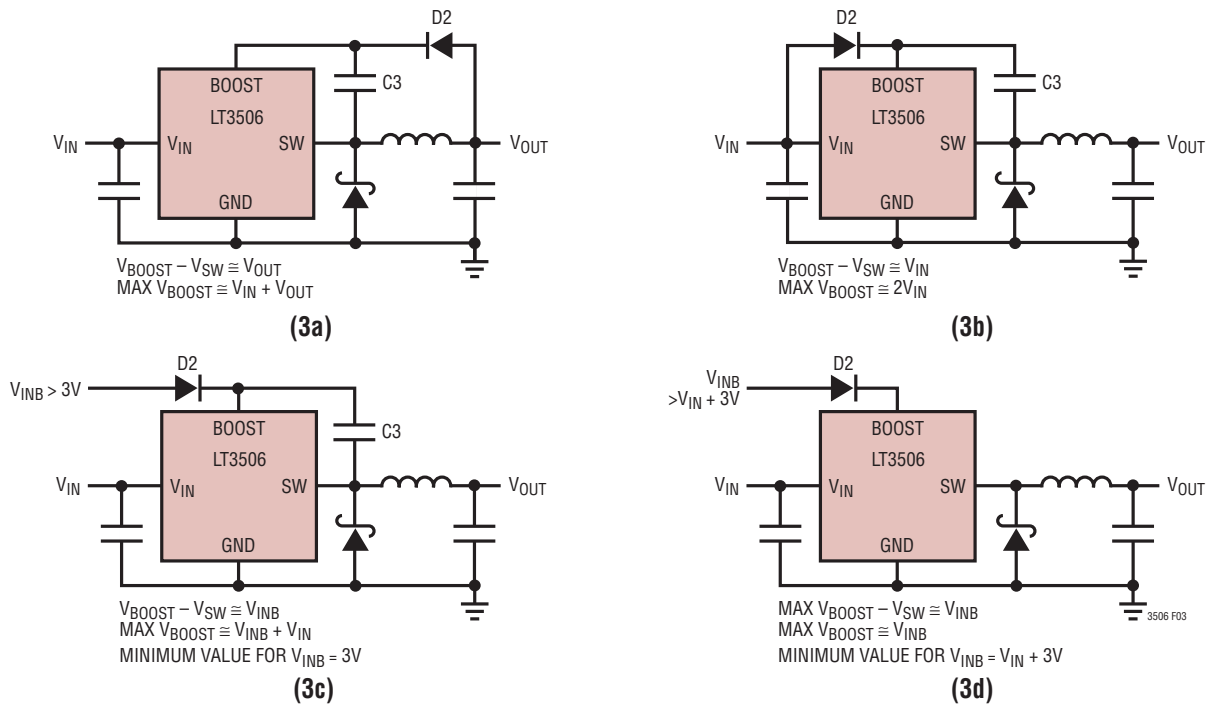
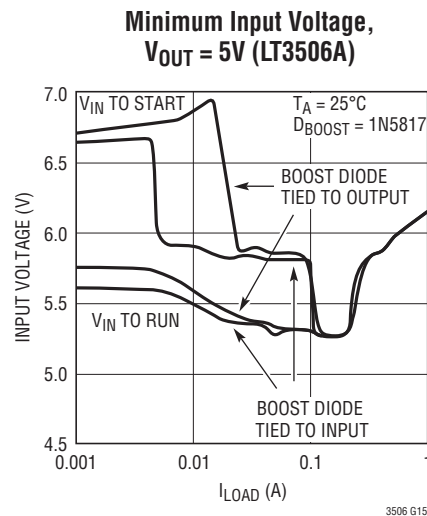
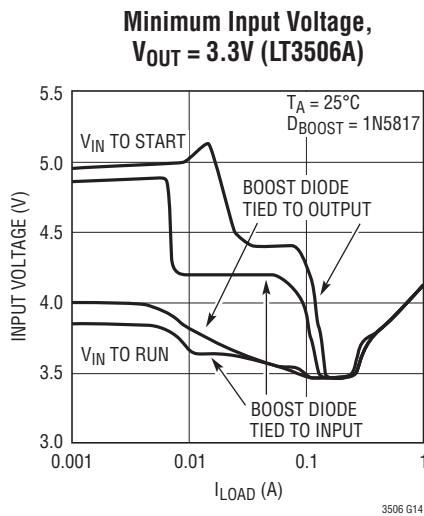

Figure 3. Generating the Boost Voltage

## APPLICATIONS INFORMATION

The minimum input voltage of an LT3506 application is limited by the minimum operating voltage (<3.6V) and by the maximum duty cycle as outlined above. For proper start-up, the minimum input voltage is also limited by the boost circuit. If the input voltage is ramped slowly, or the LT3506 is turned on with its RUN/SS pin when the output is already in regulation, then the boost capacitor may not be fully charged. Because the boost capacitor is charged with the energy stored in the inductor, the circuit will rely on some minimum load current to get the boost circuit running properly. This minimum load will depend

on input and output voltages, and on the arrangement of the boost circuit. The minimum load generally goes to zero once the circuit has started. The plots below show the minimum load current to start and to run as a function of input voltage for 3.3V and 5V outputs. In many cases the discharged output capacitor will present a load to the switcher which will allow it to start. The plots show the worst-case situation where  $V_{IN}$  is ramping very slowly. Use a Schottky diode (such as the BAT-54) for the lowest start-up voltage.





## APPLICATIONS INFORMATION

supply or glitching the input supply when the LT3506 is enabled. The RUN/SS pins do not provide an accurate delay to start or an accurately controlled ramp at the output voltage, both of which depend on the output capacitance and the load current. However, the power good indicators can be used to sequence the two outputs, as described below.

### Power Good Indicators

The PG pin is the open collector output of an internal comparator. PG remains low until the FB pin is within 10% of the final regulation voltage. Tie the PG pin to any supply with a pull-up resistor that will supply less than 250 $\mu$ A. Note that this pin will be open when the LT3506 is placed in shutdown mode (both RUN/SS pins at ground) regardless of the voltage at the FB pin. Power good is valid when the LT3506 is enabled (either RUN/SS pin is high) and  $V_{IN}$  is greater than  $\sim 2.4V$ .

### Output Sequencing

The PG and RUN/SS pins can be used to sequence the two outputs. Figure 5 shows several circuits to do this. In each case channel 1 starts first. Note that these circuits sequence the outputs during start-up. When shut down the two channels turn off simultaneously. In Figure 5a, a larger capacitor on RUN/SS2 delays channel 2 with respect to channel 1. The soft-start capacitor on RUN/SS2 should be at least twice the value of the capacitor on RUN/SS1. A larger ratio may be required, depending on the output capacitance and load on each channel. Make sure to test the circuit in the system before deciding on final values for these capacitors. The circuit in Figure 5b requires the fewest components, with both channels sharing a single soft-start capacitor. The power good comparator of channel 1 disables channel 2 until output 1 is in regulation. For independent control of channel 2, use the circuit in Figure 5c. The capacitor on RUN/SS1 is smaller than the

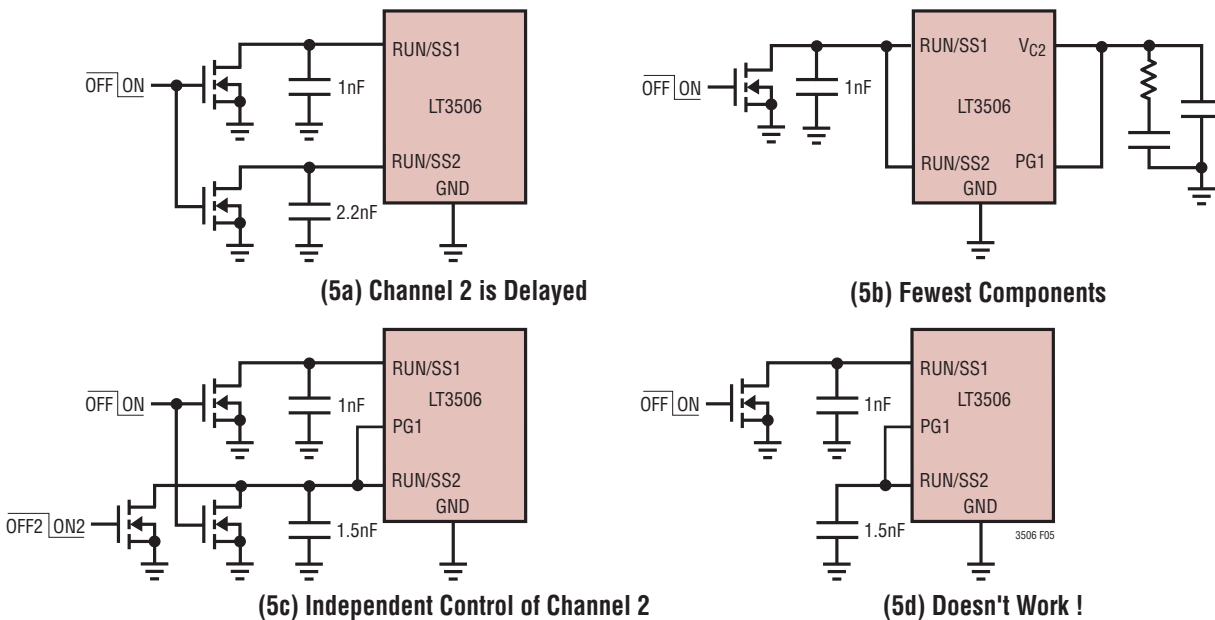

Figure 5. Sequencing the Outputs

## APPLICATIONS INFORMATION

capacitor on RUN/SS2. This allows the LT3506 to start up and enable its power good comparator before RUN/SS2 gets high enough to allow channel 2 to start switching. Channel 2 only operates when it is enabled with the external control signals and output 1 is in regulation. The circuit in Figure 5a leaves both power good indicates free. However, the circuits in Figures 5b and 5c have another advantage. As well as sequencing the two outputs at start-up, they also disable channel 2 if output 1 falls out of regulation (due to a short-circuit or a collapsing input voltage).

Finally, be aware that **the circuit in Figure 5d does not work**, because the power good comparators are disabled in shutdown. When the system is placed in shutdown mode by pulling down on RUN/SS1, then output 1 will go low, PG1 will pull down on RUN/SS2, and the LT3506 will enter its low current shutdown state. This disables PG1, and RUN/SS2 ramps up again to enable the LT3506. The circuit will oscillate and pull extra current from the input.

### Multiple Input Supplies

The internal supplies of the LT3506 operate from  $V_{IN1}$ . It is possible to supply  $V_{IN2}$  from a different source, provided  $V_{IN1}$  is above the minimum supply level whenever  $V_{IN2}$  is present. This could be used when a system has two primary supplies available. It is more efficient to generate the desired outputs with the lowest step-down ratio possible. For example, if a system has 18V and 5V power available

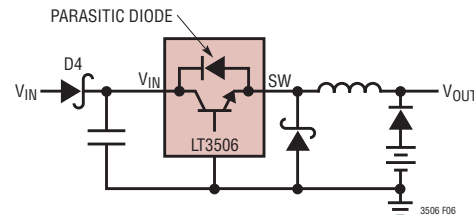

**Figure 6. Shorted Input Protection**

and needs to generate 12V and 2.5V, it would be more efficient to generate the 2.5V output from the 5V supply and the 12V output from the 18V supply. The LT3506 can step down 18V to 2.5V, but the efficiency would be lower than stepping down from 5V to 2.5V.

This feature can also be used when the maximum step-down ratio is exceeded. In this case,  $V_{IN2}$  can be tied to  $V_{OUT1}$  for applications requiring high  $V_{IN}$  to  $V_{OUT}$  ratios. A dual step-down application steps down the input voltage ( $V_{IN1}$ ) to the highest output voltage then uses that voltage to power the second channel ( $V_{IN2}$ ).  $V_{OUT1}$  must be able to provide enough current for its output plus the average current drawn from  $V_{OUT2}$ . Note that the  $V_{OUT1}$  must be above minimum input voltage for  $V_{IN2}$  when the second channel starts to switch. Delaying the second channel can be accomplished by either using independent soft-start capacitors or sequencing with the PG1 output. The Two Stage Step-Down circuit in the Applications section shows an example of the latter approach.

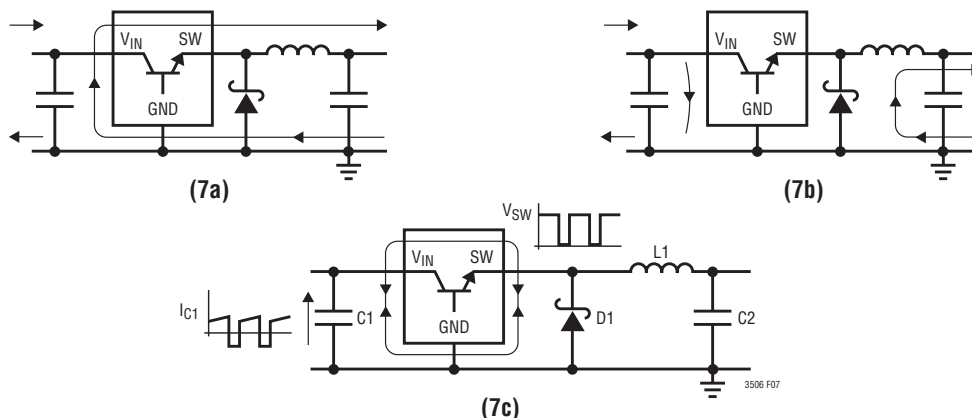

**Figure 7. Subtracting the Current when the Switch is ON (a) From the Current when the Switch is OFF (b) Reveals the Path of the High Frequency Switching Current (c) Keep This Loop Small. The Voltage on the SW and BOOST Nodes will also be Switched; Keep these Nodes as Small as Possible. Finally, Make Sure the Circuit is Shielded with a Local Ground Plane.**

## APPLICATIONS INFORMATION

### Shorted Input Protection

If the inductor is chosen so that it won't saturate excessively, the LT3506 will tolerate a shorted output. There is another situation to consider in systems where the output will be held high when the input to the LT3506 is absent. If the  $V_{IN}$  and one of the RUN/SS pins are allowed to float, then the LT3506's internal circuitry will pull its quiescent current through its SW pin. This is fine if your system can tolerate a few mA of load in this state. With both RUN/SS pins grounded, the LT3506 enters shutdown mode and the SW pin current drops to  $\sim 30\mu\text{A}$ . However, if the  $V_{IN}$  pin is grounded while the output is held high, then parasitic diodes inside the LT3506 can pull large currents from the

output through the SW pin and the  $V_{IN}$  pin. A Schottky diode in series with the input to the LT3506 will protect the LT3506 and the system from a shorted or reversed input, as shown in Figure 6.

### PCB Layout

For proper operation and minimum EMI, care must be taken during printed circuit board (PCB) layout. Figure 7 shows the high-di/dt paths in the buck regulator circuit. Note that large, switched currents flow in the power switch, the catch diode and the input capacitor. The loop formed by these components should be as small as possible. These components, along with the inductor and output capacitor, should be placed on the same side of the circuit board, and their connections should be made on that layer. Place a local, unbroken ground plane below these components, and tie this ground plane to system ground at one location, ideally at the ground terminal of the output capacitor C2. Additionally, the SW and BOOST nodes should be kept as small as possible. Figure 8 shows recommended component placement with trace and via locations.

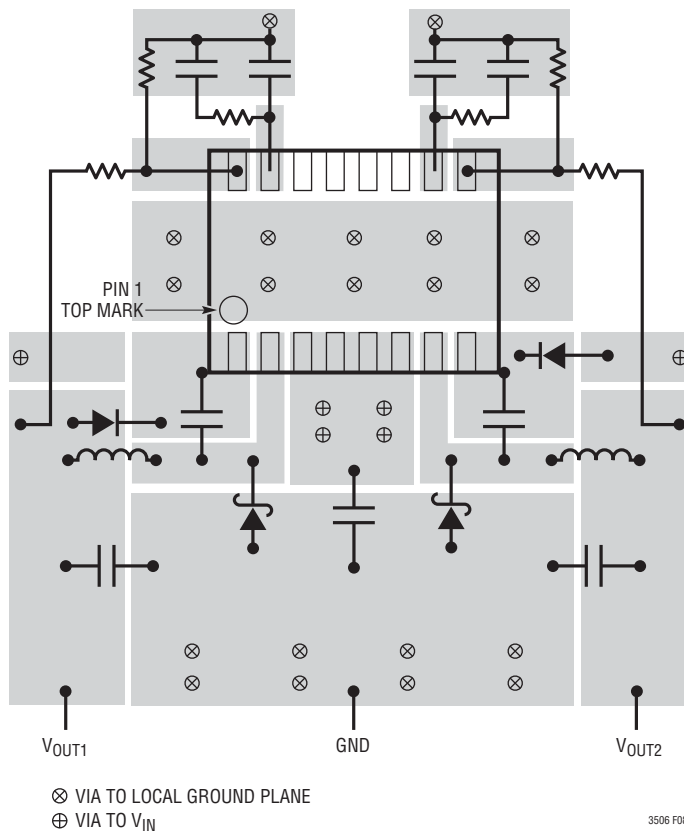

Figure 8. A Good PCB Layout Ensures Proper Low EMI Operation

### Thermal Considerations

The PCB must also provide heat sinking to keep the LT3506 cool. The exposed metal on the bottom of the package must be soldered to a ground plane. This ground should be tied to other copper layers below with thermal vias; these layers will spread the heat dissipated by the LT3506. Place additional vias near the catch diodes. Adding more copper to the top and bottom layers and tying this copper to the internal planes with vias can reduce thermal resistance further. With these steps, the thermal resistance from die (or junction) to ambient can be reduced to  $\theta_{JA} = 43^\circ\text{C/W}$ .

The power dissipation in the other power components—catch diodes, boost diodes and inductors, cause additional copper heating and can further increase what the IC sees as ambient temperature. See the LT1767 data sheet's Thermal Considerations section.

## APPLICATIONS INFORMATION

### Single, Low-Ripple 3.2A Output

The LT3506 can generate a single, low-ripple 3.2A output if the outputs of the two switching regulators are tied together and share a single output capacitor. By tying the two FB pins together and the two  $V_C$  pins together, the two channels will share the load current. There are several advantages to this two-phase buck regulator. Ripple currents at the input and output are reduced, reducing voltage ripple and allowing the use of smaller, less expensive capacitors. Although two inductors are required, each will be smaller than the inductor required for a single-phase regulator. This may be important when there are tight height restrictions on the circuit. The Typical Applications section shows circuits with maximum heights of 1.4mm, 1.8mm and 2.1mm.

There is one special consideration regarding the two phase circuit. When the difference between the input voltage and output voltage is less than 2.5V, then the boost circuits may

prevent the two channels from properly sharing current. If, for example, channel 1 gets started first, it can supply the load current, while channel 2 never switches enough current to get its boost capacitor charged. In this case, channel 1 will supply the load until it reaches current limit, the output voltage drops, and channel 2 gets started. The solution is to generate a boost supply generated from either SW pin that will service both BOOST pins. The low profile, single output 5V to 3.3V converter shown in the Typical Applications section shows how to do this.

### Other Linear Technology Publications

Application Notes 19, 35 and 44 contain more detailed descriptions and design information for buck regulators and other switching regulators. The LT1376 data sheet has a more extensive discussion of output ripple, loop compensation and stability testing. Design Note 100 shows how to generate a dual (+ and -) output supply using a buck regulator.

# TYPICAL APPLICATIONS

## 1.8V and 1.2V Outputs with Sequencing

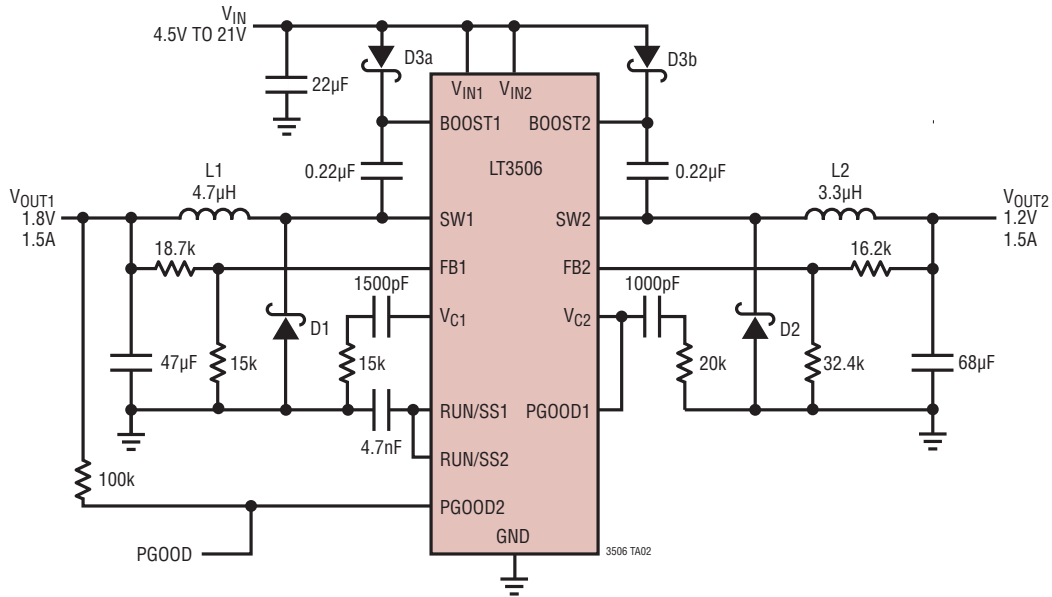

D1, D2: ON SEMICONDUCTOR MBRS230LT3      OUTPUT CURRENTS CAN INCREASE TO 1.6A WHEN  $V_{IN} > 12V$ .  
 D3: BAT-54A  
 L1: COILCRAFT MSS6122-472  
 L2: TDK SLF7028-3R3M

## 1.8V and ±5V Outputs

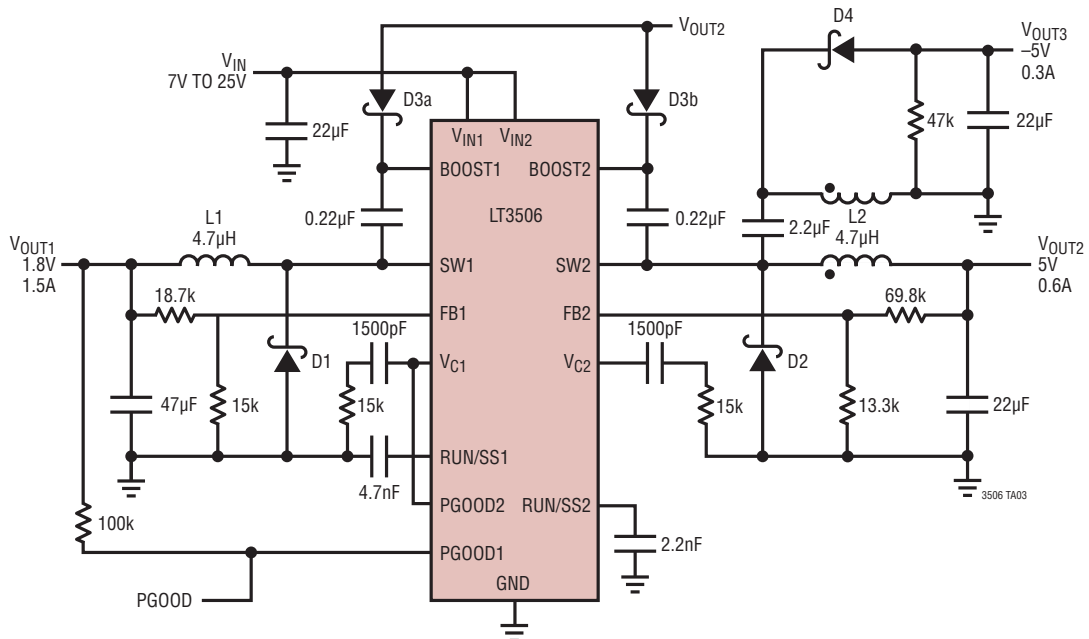

D1: ON SEMICONDUCTOR MBRS230LT3      L1: COILCRAFT MSS6122-472  
 D2: ON SEMICONDUCTOR MBRM130LT3      L2: COILTRONICS CTX5-1A  
 D3: BAT-54A  
 D4: ON SEMICONDUCTOR MBR0530  
 $I_{OUT3}$  SHOULD NEVER EXCEED 1/2 OF  $I_{OUT2}$ . SEE DESIGN NOTE 100 FOR DETAILS ON GENERATING DUAL OUTPUTS USING A BUCK REGULATOR.

## TYPICAL APPLICATIONS

Low Ripple, Low Profile 1.2V, 3A Converter, Maximum Height = 2mm

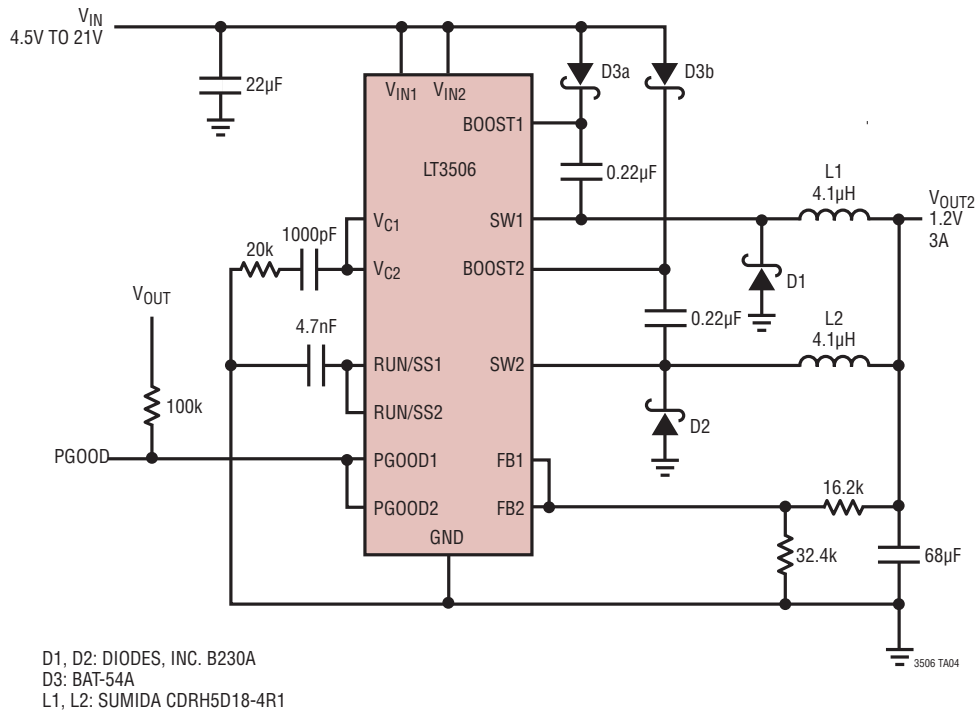

Two Stage Step Down, Up to 25V Input to 1.2V Output

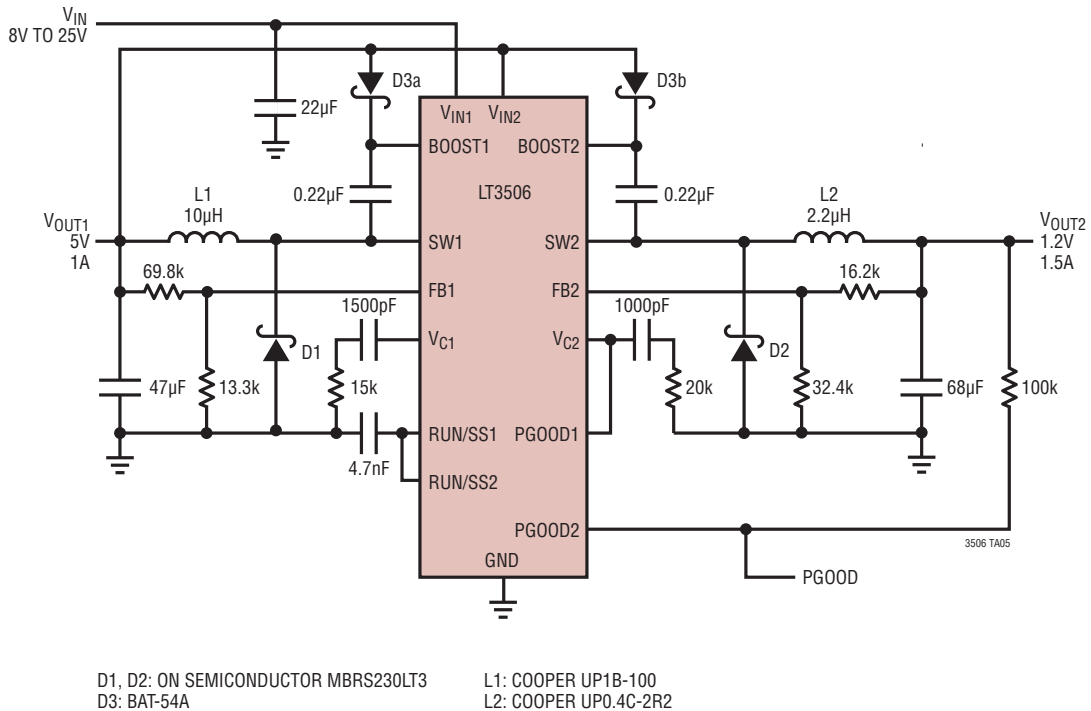

# TYPICAL APPLICATIONS

Low Ripple, Low Profile 0.8V, 3A Converter, Maximum Height = 1mm

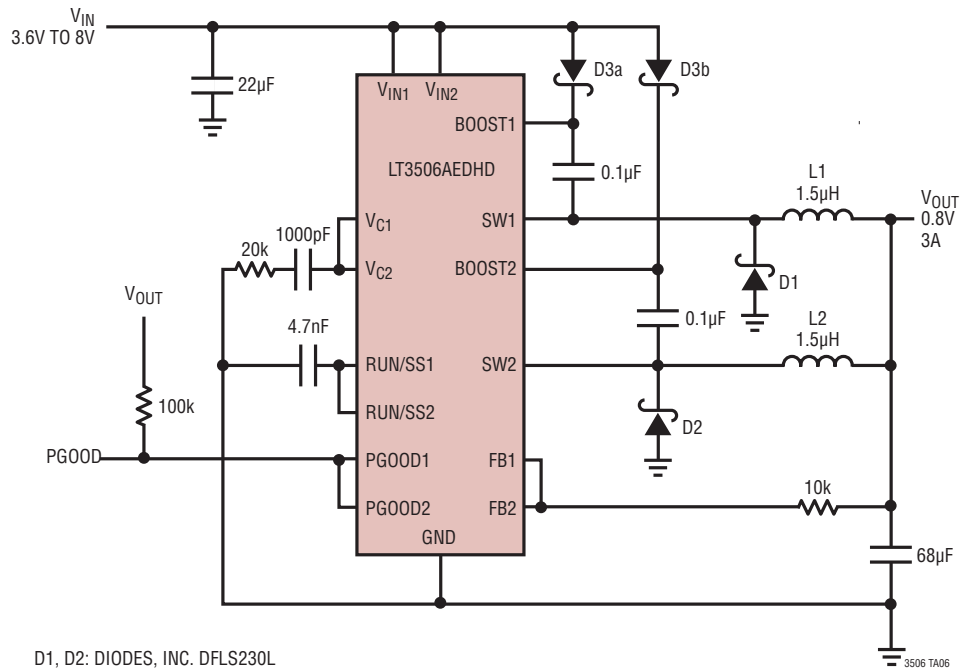

Low Profile 1.8V and 1.3V Outputs with Sequencing, Maximum Height = 1.2mm

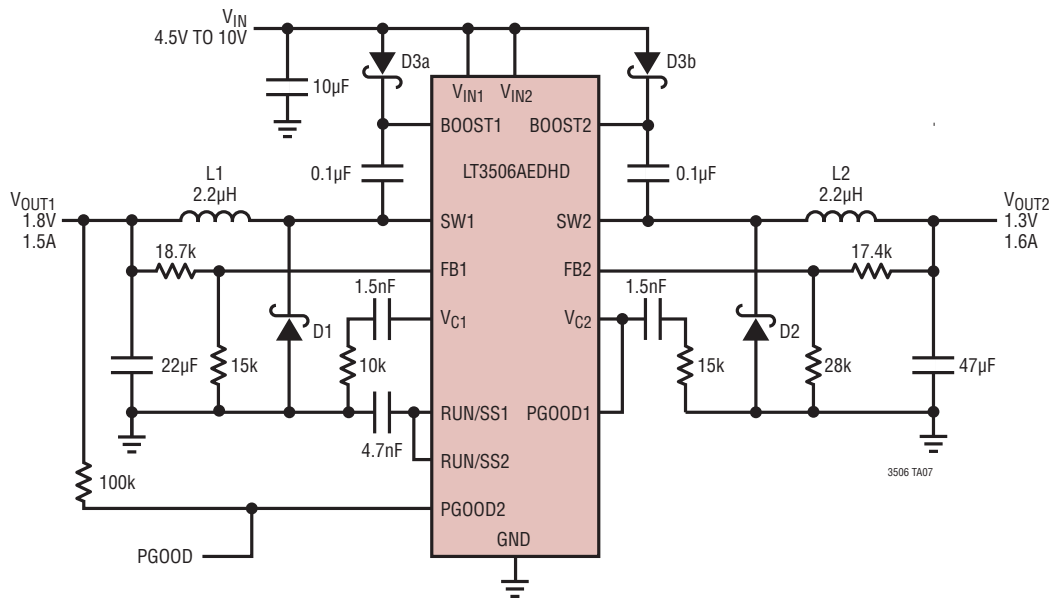

**PACKAGE DESCRIPTION**

**DHD Package**  
**16-Lead Plastic DFN (5mm × 4mm)**  
 (Reference LTC DWG # 05-08-1707)

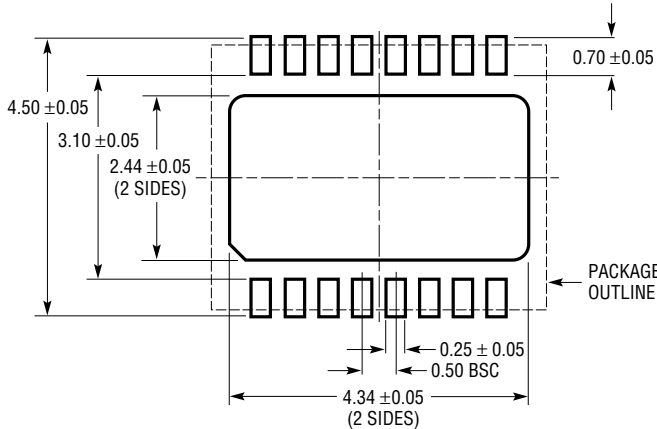

**RECOMMENDED SOLDER PAD PITCH AND DIMENSIONS**

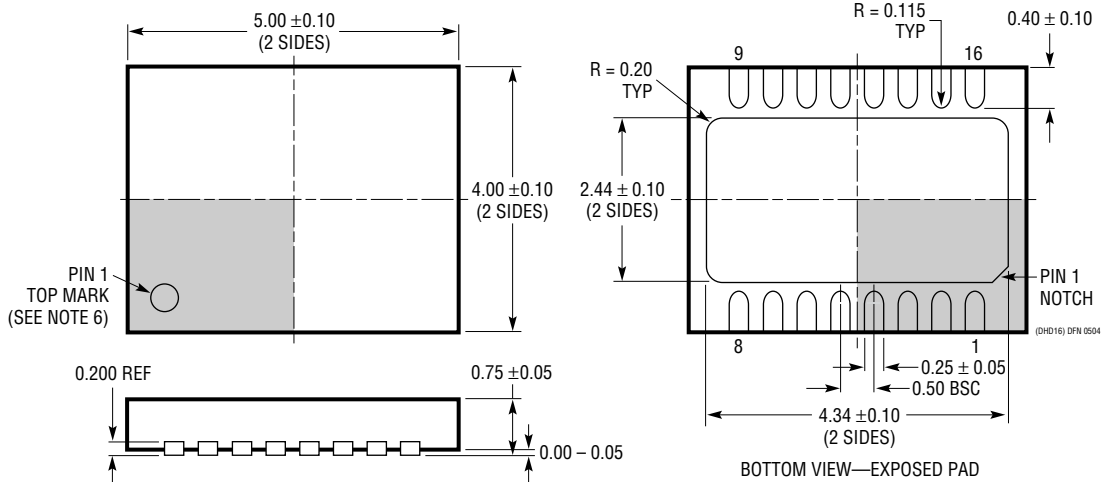

- NOTE:
1. DRAWING PROPOSED TO BE MADE VARIATION OF VERSION (WJGD-2) IN JEDEC PACKAGE OUTLINE MO-229
  2. DRAWING NOT TO SCALE
  3. ALL DIMENSIONS ARE IN MILLIMETERS
  4. DIMENSIONS OF EXPOSED PAD ON BOTTOM OF PACKAGE DO NOT INCLUDE MOLD FLASH. MOLD FLASH, IF PRESENT, SHALL NOT EXCEED 0.15mm ON ANY SIDE
  5. EXPOSED PAD SHALL BE SOLDER PLATED
  6. SHADED AREA IS ONLY A REFERENCE FOR PIN 1 LOCATION ON THE TOP AND BOTTOM OF PACKAGE

# PACKAGE DESCRIPTION

**FE Package**  
**16-Lead Plastic TSSOP (4.4mm)**  
 (Reference LTC DWG # 05-08-1663)  
**Exposed Pad Variation BA**

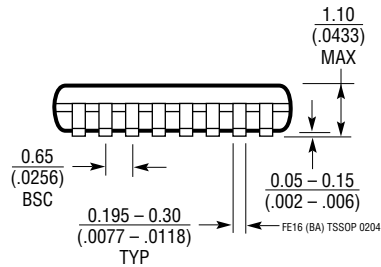
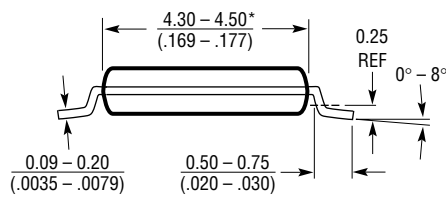
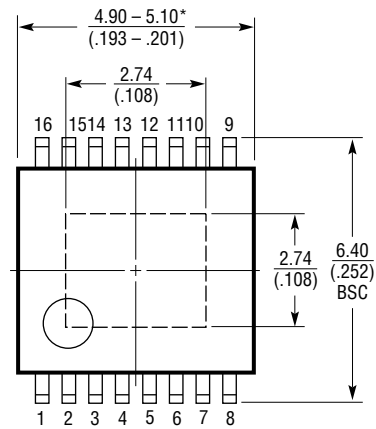
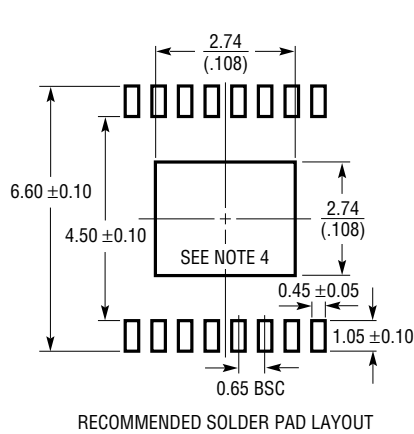

- NOTE:
1. CONTROLLING DIMENSION: MILLIMETERS
  2. DIMENSIONS ARE IN  $\frac{\text{MILLIMETERS}}{\text{(INCHES)}}$
  3. DRAWING NOT TO SCALE
  4. RECOMMENDED MINIMUM PCB METAL SIZE FOR EXPOSED PAD ATTACHMENT
- \*DIMENSIONS DO NOT INCLUDE MOLD FLASH. MOLD FLASH SHALL NOT EXCEED 0.150mm (.006") PER SIDE

# LT3506/LT3506A

## RELATED PARTS

PART NUMBER	DESCRIPTION	COMMENTS
LT1765	25V, 2.75A ( $I_{OUT}$ ), 1.25MHz, High Efficiency Step-Down DC/DC Converter	$V_{IN}$ : 3V to 25V, $V_{OUT(MIN)}$ = 1.2V, $I_Q$ = 1mA, S8, TSSOP16E Packages
LT1766	60V, 1.2A ( $I_{OUT}$ ), 200kHz, High Efficiency Step-Down DC/DC Converter	$V_{IN}$ : 5.5V to 60V, $V_{OUT(MIN)}$ = 1.2V, $I_Q$ = 2.5mA, TSSOP16/TSSOP16E Packages
LT1767	25V, 1.2A ( $I_{OUT}$ ), 1.25MHz, High Efficiency Step-Down DC/DC Converter	$V_{IN}$ : 3V to 25V, $V_{OUT(MIN)}$ = 1.2V, $I_Q$ = 1mA, MS8, MS8E Packages
LT1940/LT1940L	Dual Monolithic 1.4A, 1.1MHz Step-Down Switching Regulator	$V_{IN}$ : 3.6V to 25V, $V_{OUT(MIN)}$ = 1.25V, $I_Q$ = 3.8mA, TSSOP16E Packages
LTC3407/LTC3407-2	Dual 600mA/800mA, 1.5MHz, Synchronous Step-Down Regulator	$V_{IN}$ : 2.5V to 5.5V, $V_{OUT(MIN)}$ = 0.6V, $I_Q$ = 40mA, MSE Package
LT3493	1.2A, 750kHz Step-Down Switching Regulator in 2mm × 3mm DFN	$V_{IN}$ : 3.6V to 36V, $V_{OUT(MIN)}$ = 0.78V, $I_Q$ = 1.9mA, 2mm × 3mm DFN Package
LT3505	1.2A, 3MHz Step-Down Switching Regulator in 3mm × 3mm DFN	$V_{IN}$ : 3.6V to 36V, $V_{OUT(MIN)}$ = 0.8V, $I_Q$ = 2mA, DFN or MSE10 Package
LTC3548	Dual 800mA and 400mA, 2.25MHz, Synchronous Step-Down Regulator	$V_{IN}$ : 2.5V to 5.5V, $V_{OUT(MIN)}$ = 0.6V, $I_Q$ = 40 $\mu$ A, 3mm × 3mm DFN or MSE10 Package
LTC3549	Dual 300mA, 2.25MHz, Synchronous Step-Down Regulator	$V_{IN}$ : 2.5V to 5.5V, $V_{OUT(MIN)}$ = 0.6V, $I_Q$ = 40 $\mu$ A, 3mm × 3mm DFN Package
LTC3701	Two Phase, Dual, 500kHz, Constant Frequency, Current Mode, High Efficiency Step-Down DC/DC Controller	$V_{IN}$ : 2.5V to 10V, $V_{OUT(MIN)}$ = 0.8V, $I_Q$ = 460 $\mu$ A, SSOP-16 Package
LTC3736	Dual Two Phase, No $R_{SENSE}^{TM}$ , Synchronous Controller with Output Tracking	$V_{IN}$ : 2.75V to 9.8V, $V_{OUT(MIN)}$ = 0.6V, $I_Q$ = 300 $\mu$ A, 4mm × 4mm QFN or SSOP-24 Packages
LTC3737	Dual Two Phase, No $R_{SENSE}$ DC/DC Controller with Output Tracking	$V_{IN}$ : 2.75V to 9.8V, $V_{OUT(MIN)}$ = 0.6V, $I_Q$ = 220 $\mu$ A, 4mm × 4mm QFN or SSOP-24 Packages

No  $R_{SENSE}$  is a trademark of Linear Technology Corporation.

## Looking for pricing, stock, or lifecycle information?

Click below to explore more details on WIN SOURCE:

 [View LT3506AEDHD#PBF on WIN SOURCE](#)

 [Linear Technology](#) Information

## Optimize Your Supply Chain with WIN SOURCE Solutions

-  Global Sourcing Solution
-  Obsolete Management
-  Cost Control Management
-  Shortage Management
-  Alternative Solution
-  Excess Inventory Management