



**THE DATASHEET OF
LT3508HFE#PBF**



Dual Monolithic 1.4A Step-Down Switching Regulator

FEATURES

- **Wide Input Voltage Range: 3.7V to 36V**
- **Two 1.4A Output Switching Regulators with Internal Power Switches**
- **Adjustable 250kHz to 2.5MHz Switching Frequency**
- **Synchronizable over the Full Frequency Range**
- **Anti-Phase Switching Reduces Ripple**
- **Uses Small Inductors and Ceramic Capacitors**
- **Accurate Programmable Undervoltage Lockout**
- **Independent Tracking, Soft-Start and Power Good Circuits Ease Supply Sequencing**
- **Output Adjustable Down to 800mV**
- **Small 4mm × 4mm 24-Pin QFN or 16-Pin Thermally Enhanced TSSOP Surface Mount Packages**

APPLICATIONS

- Automotive
- DSP Power Supplies
- Wall Transformer Regulation
- DSL and Cable Modems
- PCI Express

DESCRIPTION

The LT[®]3508 is a dual current mode PWM step-down DC/DC converter with internal power switches capable of generating two 1.4A outputs. The wide input voltage range of 3.7V to 36V makes the LT3508 suitable for regulating power from a wide variety of sources, including automotive batteries, 24V industrial supplies and unregulated wall adapters. Both converters are synchronized to a single oscillator programmable up to 2.5MHz and run with opposite phases, reducing input ripple current. Its high operating frequency allows the use of small, low cost inductors and ceramic capacitors, resulting in low, predictable output ripple. Each regulator has independent tracking and soft-start circuits and generates a power good signal when its output is in regulation, easing power supply sequencing and interfacing with microcontrollers and DSPs.

Cycle-by-cycle current limit, frequency foldback and thermal shutdown provide protection against shorted outputs, and soft-start eliminates input current surge during start-up. The low current (<2 μ A) shutdown mode enables easy power management in battery-powered systems.

LT, LT, LTC, LTM, Linear Technology and the Linear logo are registered trademarks and No R_{SENSE} is a trademark of Linear Technology Corporation. All other trademarks are the property of their respective owners.

TYPICAL APPLICATION

3.3V and 5V Dual Output Step-Down Converter with Output Sequencing

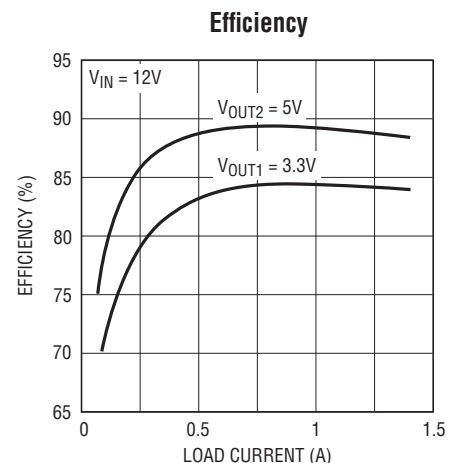
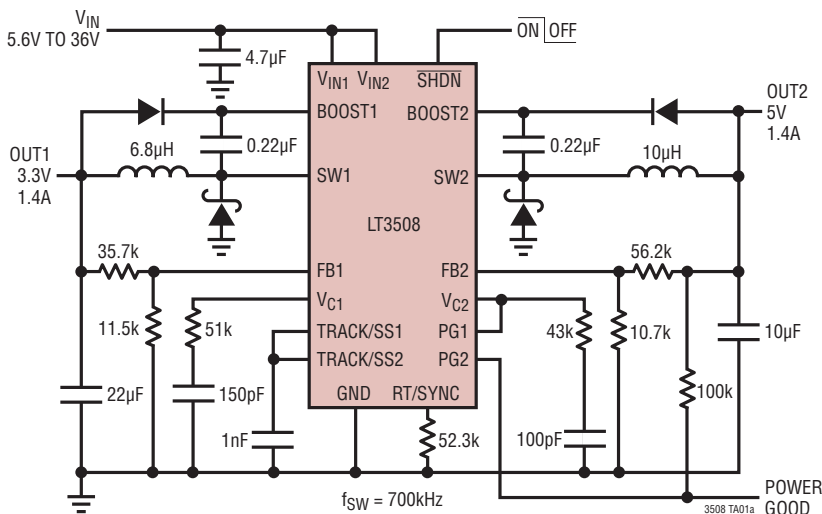

3508 TA01b
3508fd

LT3508

ABSOLUTE MAXIMUM RATINGS (Notes 1, 7)

V_{IN} Pin Voltage.....	(-0.3V), 40V	Storage Temperature Range	
BOOST Pin Voltage	60V	QFN.....	-65°C to 150°C
BOOST Above SW Voltage	30V	TSSOP	-65°C to 150°C
SHDN, PG Voltage.....	40V	Lead Temperature (Soldering, 10 sec)	
TRACK/SS, FB, RT/SYNC, V_C Voltage.....	6V	TSSOP	300°C
Operating Junction Temperature Range (Note 2)			
LT3508E.....	-40°C to 125°C		
LT3508I.....	-40°C to 125°C		
LT3508H	-40°C to 150°C		

PIN CONFIGURATION

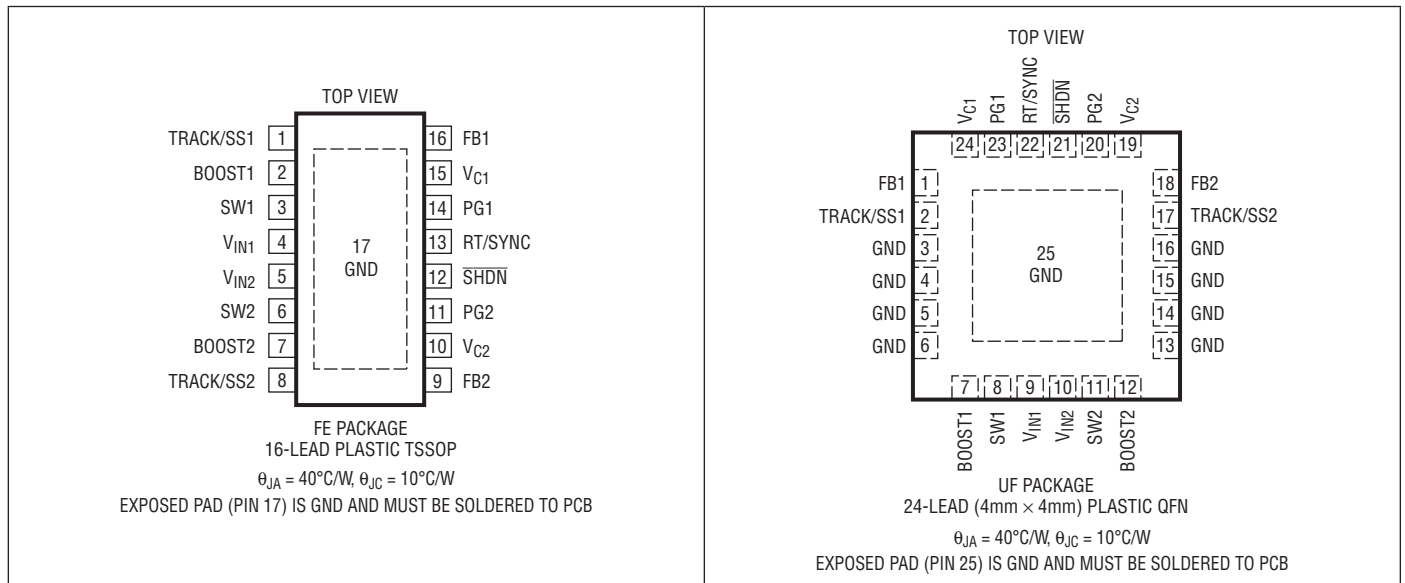

ORDER INFORMATION

LEAD FREE FINISH	TAPE AND REEL	PART MARKING*	PACKAGE DESCRIPTION	TEMPERATURE RANGE
LT3508EFE#PBF	LT3508EFE#TRPBF	3508FE	16-Lead Plastic TSSOP	-40°C to 125°C
LT3508IFE#PBF	LT3508IFE#TRPBF	3508FE	16-Lead Plastic TSSOP	-40°C to 125°C
LT3508HFE#PBF	LT3508HFE#TRPBF	3508HFE	16-Lead Plastic TSSOP	-40°C to 150°C
LT3508EUF#PBF	LT3508EUF#TRPBF	3508	24-Lead (4mm × 4mm) Plastic QFN	-40°C to 125°C
LT3508IUF#PBF	LT3508IUF#TRPBF	3508	24-Lead (4mm × 4mm) Plastic QFN	-40°C to 125°C
LT3508HUF#PBF	LT3508HUF#TRPBF	3508H	24-Lead (4mm × 4mm) Plastic QFN	-40°C to 150°C

Consult LTC Marketing for parts specified with wider operating temperature ranges. *Temperature grades are identified by a label on the shipping container. Consult LTC Marketing for information on non-standard lead based finish parts.

For more information on lead free part marking, go to: <http://www.linear.com/leadfree/>

For more information on tape and reel specifications, go to: <http://www.linear.com/tapeandreel/>

ELECTRICAL CHARACTERISTICS The ● denotes the specifications which apply over the full operating temperature range, otherwise specifications are at $T_A = 25^\circ\text{C}$. $V_{IN} = 12\text{V}$ unless otherwise noted. (Note 2)

PARAMETER	CONDITIONS		MIN	TYP	MAX	UNITS
Minimum Operating Voltage, V_{IN1}		●		3.4	3.7	V
Minimum Operating Voltage, V_{IN2}	$V_{IN1} = 12\text{V}$	●		2.5	3.0	V
V_{IN1} Quiescent Current	Not Switching			4.3	5.2	mA
V_{IN2} Quiescent Current	Not Switching			320	500	μA
Shutdown Current ($V_{IN1} + V_{IN2}$)	$V_{SHDN} = 0.3\text{V}$			0.1	2	μA
FB Voltage		●	0.790 0.784	0.800	0.814 0.816	V V
FB Pin Bias Current (Note 3)	$V_{FB} = 0.800\text{V}$, $V_C = 0.5\text{V}$	●		50	300	nA
FB Voltage Line Regulation	$5\text{V} < V_{IN} < 40\text{V}$			0.01		%/V
Error Amp Transconductance				300		μS
Error Amp Voltage Gain				600		V/V
V_C to Switch Current Gain				2.5		A/V
Switching Frequency	$R_T = 33.2\text{k}$	●	0.92	1	1.06	MHz
Switching Phase	$R_T = 33.2\text{k}$		150	180	210	Deg
Maximum Duty Cycle (Note 4)	$R_T = 33.2\text{k}$ $R_T = 7.50\text{k}$ $R_T = 169\text{k}$	●	84	90 80 98		% % %
Foldback Frequency	$R_T = 33.2\text{k}$, $V_{FB} = 0\text{V}$			120		kHz
Switch Current Limit (Note 5)	Duty Cycle = 15%	●	2.0	2.6	3.2	A
Switch V_{CESAT}	$I_{SW} = 1.5\text{A}$			300		mV
Switch Leakage Current				0.01	1	μA
Minimum Boost Voltage				1.7	2.5	V
Boost Pin Current	$I_{SW} = 1.5\text{A}$, $V_{BOOST} = 17\text{V}$			35	50	mA
TRACK/SS Pin Current	$V_{TRACK/SS} = 0\text{V}$		0.8	1.2	2.2	μA
PG Threshold Offset	V_{FB} Rising		56	75	110	mV
PG Voltage Output Low	$V_{FB} = 0.6\text{V}$, $I_{PG} = 250\mu\text{A}$			0.13	0.4	V
PG Pin Leakage	$V_{PG} = 2\text{V}$			0.01	1	μA
SHDN Threshold Voltage			2.53	2.63	2.73	V
SHDN Input Current (Note 6)	$V_{SHDN} = 60\text{mV}$ Above Threshold Voltage		6	8	10	μA
SHDN Threshold Current Hysteresis			5.5	7.5	9.5	μA
SYNC Threshold Voltage			1	1.25	1.5	V
SYNC Input Frequency			0.25		2.5	MHz

Note 1: Stresses beyond those listed under Absolute Maximum Ratings may cause permanent damage to the device. Exposure to any Absolute Maximum Rating condition for extended periods may affect device reliability and lifetime.

Note 2: The LT3508E is guaranteed to meet performance specifications from 0°C to 125°C junction temperature. Specifications over the -40°C to 125°C operating junction temperature range are assured by design, characterization and correlation with statistical process controls. The LT3508I is guaranteed over the full -40°C to 125°C operating junction temperature range. The LT3508H is guaranteed over the full -40°C to 150°C operating junction temperature range. High junction temperatures degrade operating lifetimes. Operating lifetime is derated at junction temperatures greater than 125°C .

Note 3: Current flows out of pin.

Note 4: $V_{BOOST} = 12\text{V}$. Circuitry increases the maximum duty cycle of the LT3508 when $V_{BOOST} > V_{IN} + 2.5\text{V}$. See Minimum Operating Voltage in the Applications Information section for details.

Note 5: Current limit is guaranteed by design and/or correlation to static test. Slope compensation reduces current limit at higher duty cycles.

Note 6: Current flows into pin.

Note 7: This IC includes overtemperature protection that is intended to protect the device during momentary overload conditions. Junction temperature will exceed the maximum operating junction temperature range when overtemperature protection is active. Continuous operation above the specified maximum operating junction temperature may impair device reliability.

TYPICAL PERFORMANCE CHARACTERISTICS

Efficiency, $V_{OUT} = 5V$

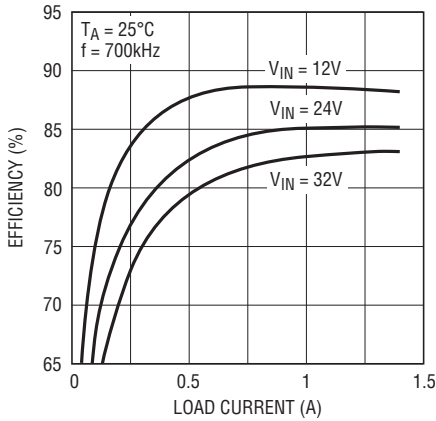

3508 G01

Efficiency, $V_{OUT} = 3.3V$

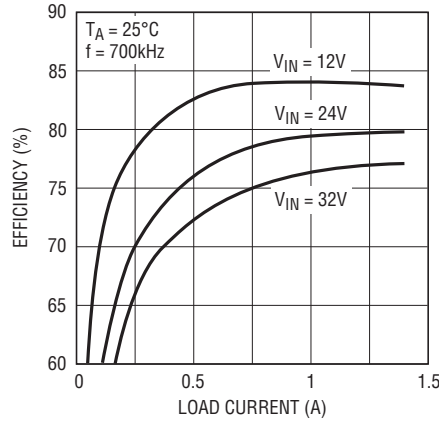

3508 G02

Efficiency, $V_{OUT} = 1.8V$

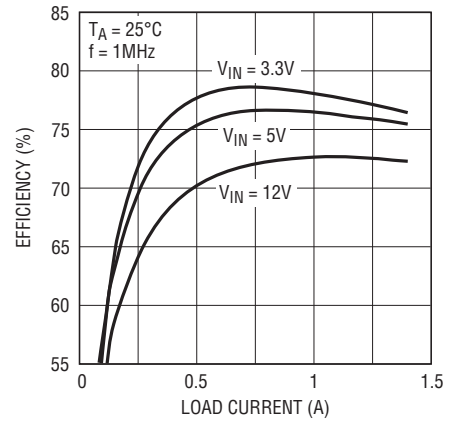

3508 G03

Feedback Voltage

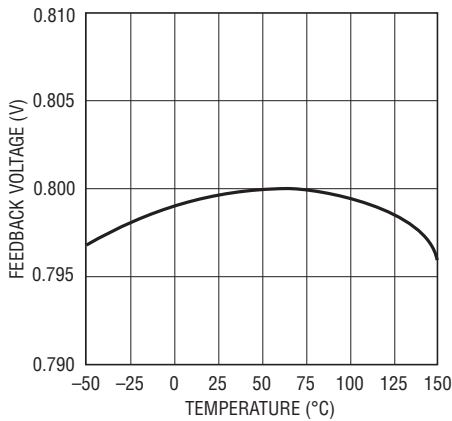

3508 G04

Switch Current Limit vs Temperature

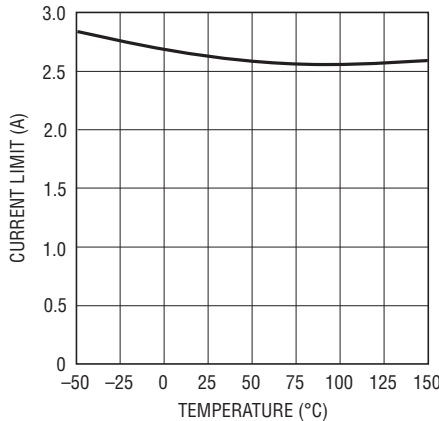

3508 G05

Switch Current Limit vs Duty Cycle

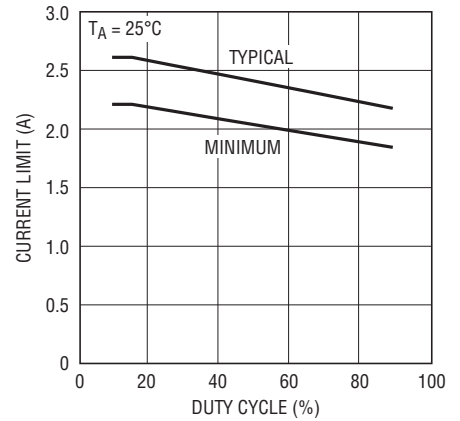

3508 G06

Switching Frequency vs R_T

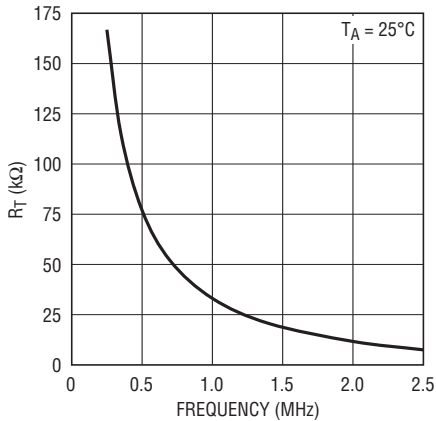

3508 G07

Switching Frequency vs Temperature

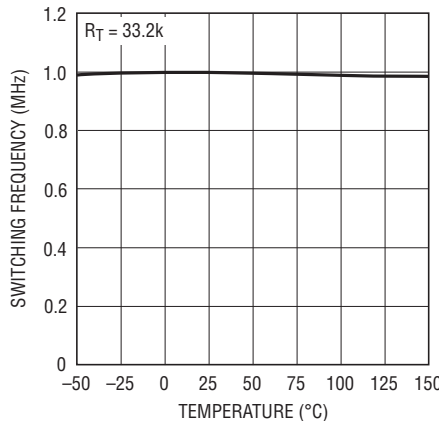

3508 G08

Switching Frequency Foldback

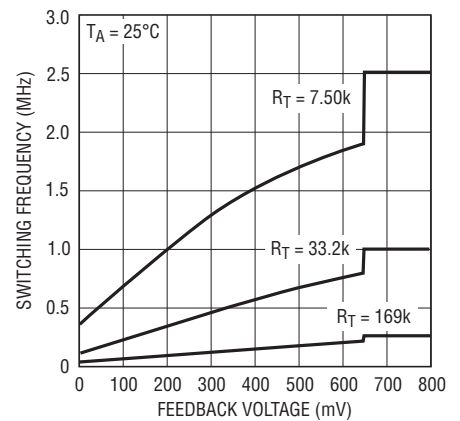

3508 G09

TYPICAL PERFORMANCE CHARACTERISTICS

Quiescent Current

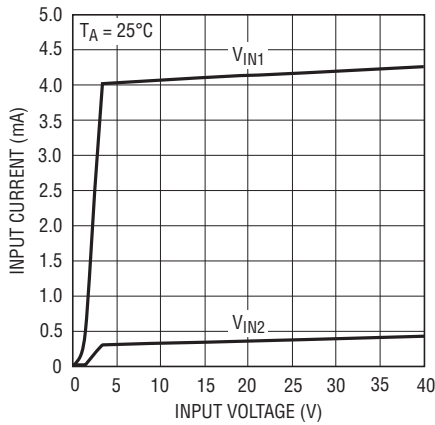

3508 G10

V_C Voltages

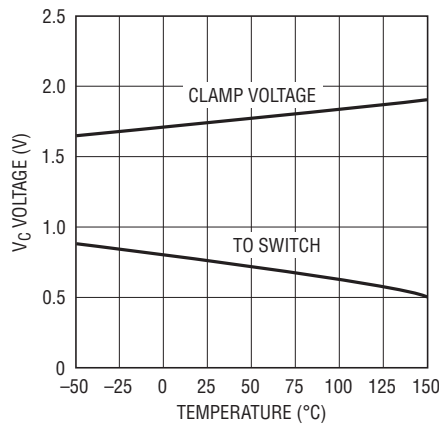

3508 G11

Error Amp Output Current

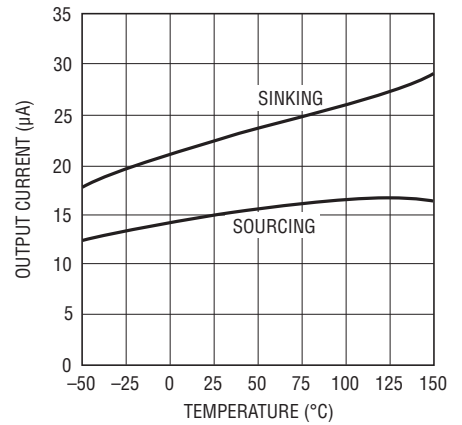

3508 G12

Switch Voltage Drop

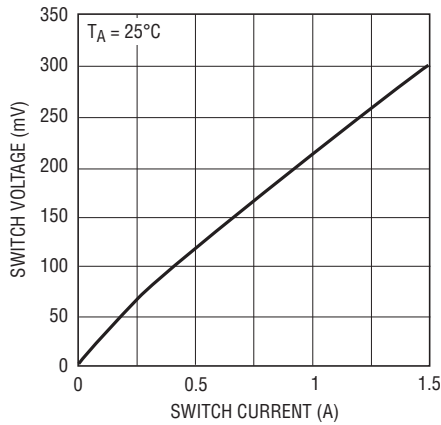

3508 G13

Boost Pin Current

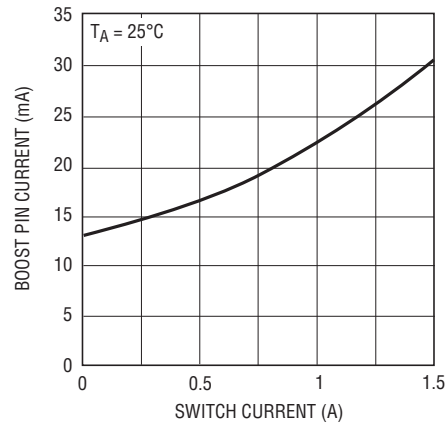

3508 G14

SHDN Pin Current

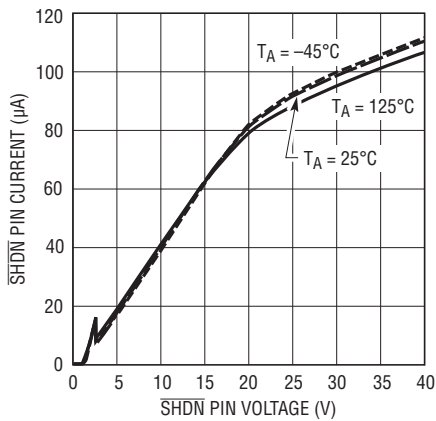

3508 G15

Undervoltage Lockout

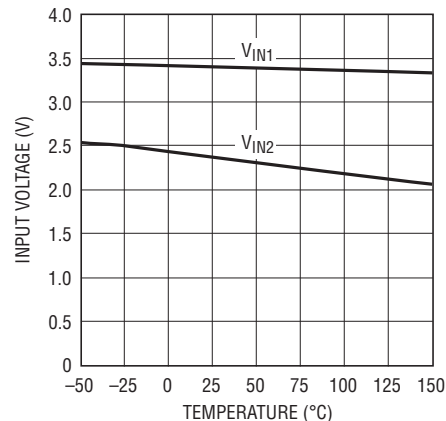

3508 G16

PIN FUNCTIONS

BOOST1, BOOST2: The BOOST pins are used to provide drive voltages, higher than the input voltage, to the internal NPN power switches. Tie through a diode to a 2.8V or higher supply, such as V_{OUT} or V_{IN} .

Exposed Pad: The exposed pad metal of the package provides both electrical contact to ground and good thermal contact to the printed circuit board. The exposed pad must be soldered to the circuit board for proper operation.

FB1, FB2: The LT3508 regulates each feedback pin to 0.800V. Connect the feedback resistor divider taps to these pins.

GND: Tie the GND pins directly to the Exposed Pad and ground plane.

PG1, PG2: The power good pins are the open-collector outputs of an internal comparator. PG remains low until the FB pin is within 10% of the final regulation voltage. As well as indicating output regulation, the PG pins can be used to sequence the two switching regulators. These pins can be left unconnected. The PG outputs are valid when V_{IN1} is greater than 3.7V and \overline{SHDN} is high. The PG comparators are disabled in shutdown.

RT/SYNC: The RT/SYNC pin is used to set the internal oscillator frequency. Tie a 33.2k resistor from RT/SYNC to GND for a 1MHz switching frequency. To synchronize the part to an external frequency, drive the RT/SYNC pin with a logic-level signal with positive and negative pulse widths of at least 80ns.

SHDN: The shutdown pin is used to put the LT3508 in shutdown mode. Pull the pin below 0.3V to shut down the LT3508. The 2.63V threshold can function as an accurate undervoltage lockout (UVLO), preventing the regulator

from operating until the input voltage has reached the programmed level. Do not drive \overline{SHDN} more than 6V above V_{IN1} .

SW1, SW2: The SW pins are the outputs of the internal power switches. Connect these pins to the inductors, catch diodes and boost capacitors.

TRACK/SS1, TRACK/SS2: The TRACK/SS pins are used to soft-start the two channels, to allow one channel to track the other output, or to allow both channels to track another output. For tracking, tie a resistor divider to this pin from the tracked output. For soft-start, tie a capacitor to this pin. An internal 1.2 μ A soft-start current charges the capacitor to create a voltage ramp at the pin. In the TSSOP package, if these pins are unused, tie a 47pF or greater capacitor from each pin to GND.

V_{C1}, V_{C2}: The V_C pins are the outputs of the internal error amps. The voltages on these pins control the peak switch currents. These pins are normally used to compensate the control loops, but can also be used to override the loops. Pull these pins to ground with an open drain to shut down each switching regulator separately.

V_{IN1}: The V_{IN1} pin supplies current to the LT3508 internal circuitry and to the internal power switch connected to SW1 and must be locally bypassed. V_{IN1} must be greater than 3.7V for channel 1 or channel 2 to operate. If V_{IN1} is greater than 3.7V, channel 2 can operate with V_{IN2} as low as 3V.

V_{IN2}: The V_{IN2} pin supplies current to the internal power switch connected to SW2 and must be locally bypassed. Connect this pin directly to V_{IN1} unless power for channel 2 is coming from a different source. V_{IN2} must be greater than 3V and V_{IN1} must be greater than 3.7V for channel 2 to operate.

BLOCK DIAGRAM

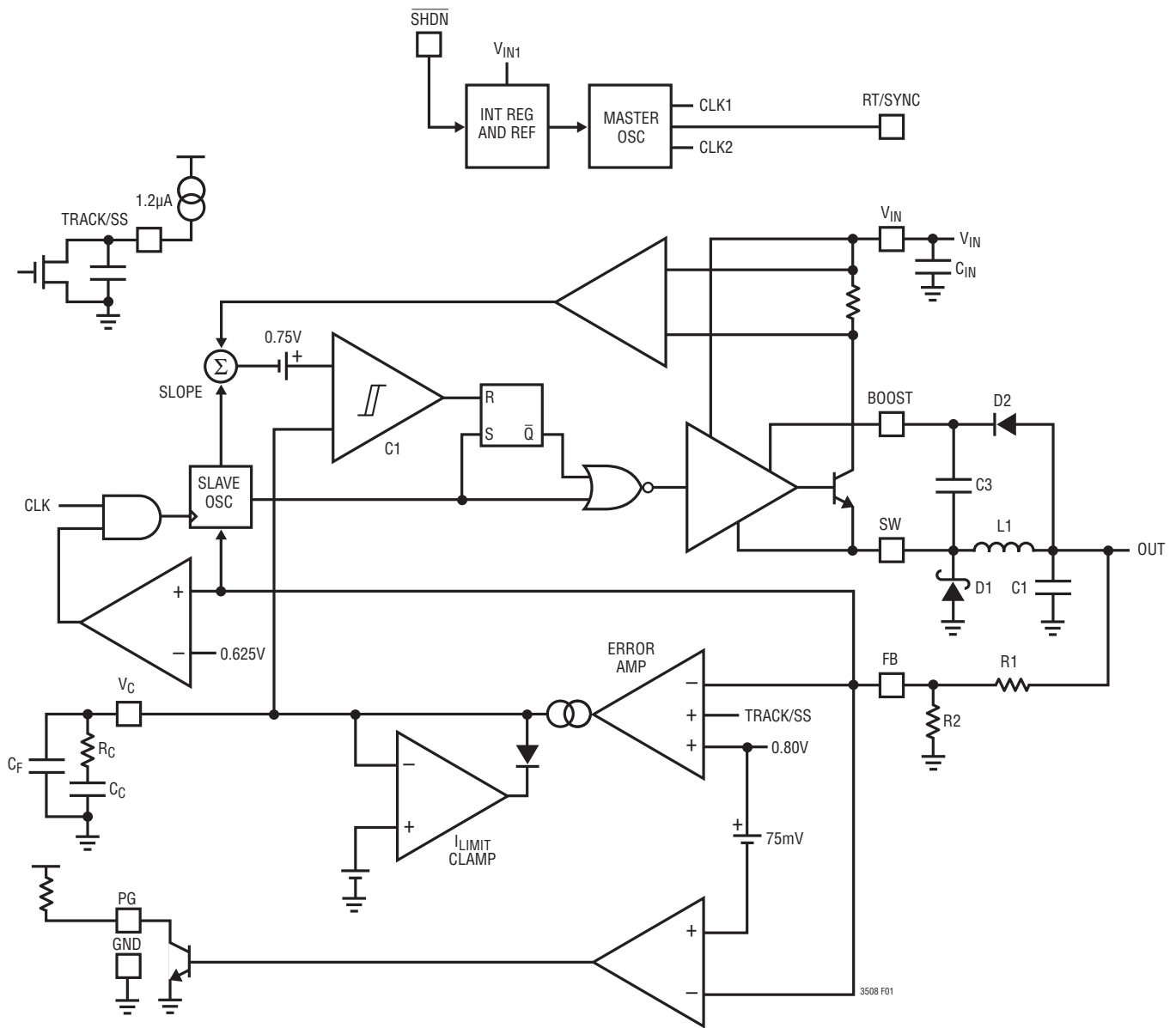

Figure 1. Block Diagram of the LT3508 with Associated External Components (One of Two Switching Regulators Shown)

OPERATION

The LT3508 is a dual constant frequency, current mode regulator with internal power switches. Operation can be best understood by referring to the Block Diagram. If the $\overline{\text{SHDN}}$ pin is tied to ground, the LT3508 is shut down and draws minimal current from the input source tied to the V_{IN} pins. If the $\overline{\text{SHDN}}$ pin exceeds 1V, the internal bias circuits turn on, including the internal regulator, reference and oscillator. The switching regulators will only begin to operate when the $\overline{\text{SHDN}}$ pin exceeds 2.63V.

The switcher is a current mode regulator. Instead of directly modulating the duty cycle of the power switch, the feedback loop controls the peak current in the switch during each cycle. Compared to voltage mode control, current mode control improves loop dynamics and provides cycle-by-cycle current limit. A pulse from the oscillator sets the RS flip-flop and turns on the internal NPN power switch. Current in the switch and the external inductor begins to increase. When this current exceeds a level determined by the voltage at V_{C} , current comparator C1 resets the flip-flop, turning off the switch. The current in the inductor flows through the external Schottky diode and begins to decrease. The cycle begins again at the next pulse from the oscillator. In this way, the voltage on the V_{C} pin controls the current through the inductor to the output. The internal error amplifier regulates the output current by continually adjusting the V_{C} pin voltage. The threshold for switching on the V_{C} pin is 0.8V, and an active clamp of 1.75V limits the output current.

The switching frequency is set either by the resistance to GND at the RT/SYNC pin or the frequency of the logic-level signal driving the RT/SYNC pin. A detection circuit monitors for the presence of a SYNC signal on the pin and switches

between the two modes. Unique circuitry generates the appropriate slope compensation ramps and generates the 180° out-of-phase clocks for the two channels.

The switching regulator performs frequency foldback during overload conditions. An amplifier senses when V_{FB} is less than 0.625V and begins decreasing the oscillator frequency down from full frequency to 12% of the nominal frequency when $V_{\text{FB}} = 0\text{V}$. The FB pin is less than 0.8V during start-up, short-circuit and overload conditions. Frequency foldback helps limit switch current under these conditions.

The switch driver operates either from V_{IN} or from the BOOST pin. An external capacitor and Schottky diode are used to generate a voltage at the BOOST pin that is higher than the input supply. This allows the driver to saturate the internal bipolar NPN power switch for efficient operation.

The TRACK/SS pin serves as an alternative input to the error amplifier. The amplifier will use the lowest voltage of either the reference of 0.8V or the voltage on the TRACK/SS pin as the positive input of error amplifier. Since the TRACK/SS pin is driven by a constant current source, a single capacitor on the pin will generate a linear ramp on the output voltage. Tying the TRACK/SS pin to a resistor divider from the output of one of the switching regulators allows one output to track another.

The PG output is an open-collector transistor that is off when the output is in regulation, allowing an external resistor to pull the PG pin high. Power good is valid when the LT3508 is enabled ($\overline{\text{SHDN}}$ is high) and $V_{\text{IN}1}$ is greater than 3.7V.

APPLICATIONS INFORMATION

Setting the Output Voltage

The output voltage is programmed with a resistor divider between the output and the FB pin. Choose the 1% resistors according to:

$$R1 = R2 \left(\frac{V_{OUT}}{0.8V} - 1 \right)$$

R2 should be 20k or less to avoid bias current errors. Reference designators refer to the Block Diagram.

Minimum Operating Voltage

The minimum operating voltage is determined either by the LT3508's undervoltage lockout or by its maximum duty cycle. If V_{IN1} and V_{IN2} are tied together, the undervoltage lockout is at 3.7V or below. If the two inputs are used separately, then V_{IN1} has an undervoltage lockout of 3.7V or below and V_{IN2} has an undervoltage lockout of 3V or below. Because the internal supply runs off V_{IN1} , channel 2 will not operate unless $V_{IN1} > 3.7V$. The duty cycle is the fraction of time that the internal switch is on and is determined by the input and output voltages:

$$DC = \frac{V_{OUT} + V_F}{V_{IN} - V_{SW} + V_F}$$

Unlike many fixed frequency regulators, the LT3508 can extend its duty cycle by turning on for multiple cycles. The LT3508 will not switch off at the end of each clock cycle if there is sufficient voltage across the boost capacitor (C3 in Figure 1). Eventually, the voltage on the boost capacitor falls and requires refreshing. Circuitry detects this condition and forces the switch to turn off, allowing the inductor current to charge up the boost capacitor. This places a limitation on the maximum duty cycle as follows:

$$DC_{MAX} = \frac{1}{1 + \frac{1}{\beta_{SW}}}$$

where β_{SW} is equal to the SW pin current divided by the BOOST pin current as shown in the Typical Performance Characteristics section. This leads to a minimum input voltage of:

$$V_{IN(MIN)} = \frac{V_{OUT} + V_F}{DC_{MAX}} - V_F + V_{SW}$$

where V_F is the forward voltage drop of the catch diode (~0.4V) and V_{SW} is the voltage drop of the internal switch (~0.4V at maximum load).

Example: $I_{SW} = 1.5A$ and $I_{BOOST} = 50mA$, $V_{OUT} = 3.3V$, $\beta_{SW} = 1.5A/50mA = 30$, $DC_{MAX} = 1/(1+1/30) = 96\%$:

$$V_{IN(MIN)} = \frac{3.3V + 0.4V}{96\%} - 0.4V + 0.4V = 3.8V$$

Maximum Operating Voltage

The maximum operating voltage is determined by the Absolute Maximum Ratings of the V_{IN} and BOOST pins, and by the minimum duty cycle:

$$DC_{MIN} = t_{ON(MIN)} \cdot f$$

where $t_{ON(MIN)}$ is equal to 130ns (for $T_J > 125^\circ C$ $t_{ON(MIN)}$ is equal to 150ns) and f is the switching frequency. Running at a lower switching frequency allows a lower minimum duty cycle. The maximum input voltage before pulse skipping occurs depends on the output voltage and the minimum duty cycle:

$$V_{IN(PS)} = \frac{V_{OUT} + V_F}{DC_{MIN}} - V_F + V_{SW}$$

Example: $f = 790kHz$, $V_{OUT} = 3.3V$, $DC_{MIN} = 130ns \cdot 790kHz = 0.103$:

$$V_{IN(PS)} = \frac{3.3V + 0.4V}{0.103} - 0.4V + 0.4V = 36V$$

The LT3508 will regulate the output current at input voltages greater than $V_{IN(PS)}$. For example, an application with an output voltage of 1.8V and switching frequency of 1.5MHz has a $V_{IN(PS)}$ of 11.3V, as shown in Figure 2. Figure 3 shows operation at 18V. Output ripple and peak inductor current have significantly increased. Exceeding $V_{IN(PS)}$ is safe if the output is in regulation, if the external components have adequate ratings to handle the peak conditions and if the peak inductor current does not exceed 3.2A. A saturating inductor may further reduce performance. Do not exceed $V_{IN(PS)}$ during start-up or overload conditions (for outputs greater than 5V, use $V_{OUT} = 5V$ to calculate $V_{IN(PS)}$). For operation above 20V in pulse skipping mode, program the switching frequency to 1.1MHz or less.

APPLICATIONS INFORMATION

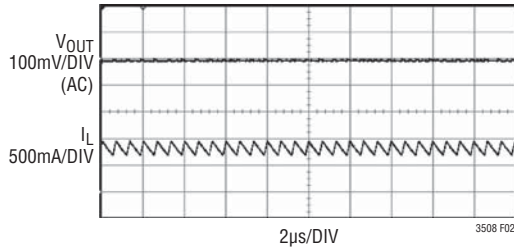

Figure 2. Operation Below $V_{IN(PS)}$. $V_{IN} = 10V$, $V_{OUT} = 1.8V$ and $f_{SW} = 1.5MHz$

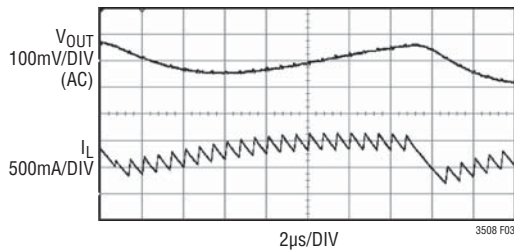

Figure 3. Operation Above $V_{IN(PS)}$. $V_{IN} = 18V$, $V_{OUT} = 1.8V$ and $f_{SW} = 1.5MHz$. Output Ripple and Peak Inductor Current Increase

Setting the Switching Frequency

The switching frequency is programmed either by driving the RT/SYNC pin with a logic level SYNC signal or by tying a resistor from the RT/SYNC pin to ground. A graph for selecting the value of R_T for a given operating frequency is shown in the Typical Application section. Suggested programming resistors for various switching frequencies are shown in Table 1.

Choosing a high switching frequency will allow the smallest overall solution size. However, at high input voltages the efficiency can drop significantly with increasing switching frequency. The choice of switching frequency will also impact the input voltage range, inductor and capacitor selection, and compensation. See the related sections for details.

Table 1. Programming the Switching Frequency

SWITCHING FREQUENCY (MHz)	R_T (k Ω)
2.5	7.50
2.2	9.76
2	11.5
1.8	14
1.6	16.9
1.4	20.5
1.2	26.1
1	33.2
0.9	38.3
0.8	44.2
0.7	52.3
0.6	61.9
0.5	76.8
0.45	88.7
0.4	100
0.35	115
0.3	140
0.25	169

Inductor Selection and Maximum Output Current

A good first choice for the inductor value is:

$$L = (V_{OUT} + V_F) \cdot \frac{1.2\mu H}{f}$$

where V_F is the voltage drop of the catch diode (~0.4V) and f is in MHz. The inductor's RMS current rating must be greater than the maximum load current and its saturation current should be at least 30% higher. For highest efficiency, the series resistance (DCR) should be less than 0.1 Ω . Table 2 lists several vendors and types that are suitable.

Table 2. Inductor Vendors

VENDOR	URL	PART SERIES	TYPE
Coilcraft	www.coilcraft	MSS7341	Shielded
Murata	www.murata.com	LQH55D	Open
TDK	www.component.tdk.com	SLF7045	Shielded
		SLF10145	Shielded
Toko	www.toko.com	DC62CB	Shielded
		D63CB	Shielded
		D75C	Shielded
		D75F	Open
Sumida	www.sumida.com	CR54	Open
		CDRH74	Shielded
		CDRH6D38	Shielded
		CR75	Open
			Open

APPLICATIONS INFORMATION

The optimum inductor for a given application may differ from the one indicated by this simple design guide. A larger value inductor provides a higher maximum load current, and reduces the output voltage ripple. If your load is lower than the maximum load current, then you can relax the value of the inductor and operate with higher ripple current. This allows you to use a physically smaller inductor, or one with a lower DCR resulting in higher efficiency. Be aware that if the inductance differs from the simple rule above, then the maximum load current will depend on input voltage. In addition, low inductance may result in discontinuous mode operation, which further reduces maximum load current. For details of discontinuous mode operation, see Application Note 44. Finally, for duty cycles greater than 50% ($V_{OUT}/V_{IN} > 0.5$), a minimum inductance is required to avoid sub-harmonic oscillations:

$$L_{MIN} = (V_{OUT} + V_F) \cdot \frac{0.8\mu H}{f}$$

where f is in MHz. The current in the inductor is a triangle wave with an average value equal to the load current. The peak switch current is equal to the output current plus half the peak-to-peak inductor ripple current. The LT3508 limits its switch current in order to protect itself and the system from overload faults. Therefore, the maximum output current that the LT3508 will deliver depends on the switch current limit, the inductor value, and the input and output voltages.

When the switch is off, the potential across the inductor is the output voltage plus the catch diode drop. This gives the peak-to-peak ripple current in the inductor:

$$\Delta I_L = \frac{(1-DC)(V_{OUT} + V_F)}{L \cdot f}$$

where f is the switching frequency of the LT3508 and L is the value of the inductor. The peak inductor and switch current is:

$$I_{SW(PK)} = I_{L(PK)} = I_{OUT} + \frac{\Delta I_L}{2}$$

To maintain output regulation, this peak current must be less than the LT3508's switch current limit I_{LIM} . I_{LIM} is at least 2A for at low duty cycles and decreases linearly

to 1.55A at DC = 90%. The maximum output current is a function of the chosen inductor value:

$$I_{OUT(MAX)} = I_{LIM} - \frac{\Delta I_L}{2} = 2A \cdot (1 - 0.25 \cdot DC) - \frac{\Delta I_L}{2}$$

Choosing an inductor value so that the ripple current is small will allow a maximum output current near the switch current limit.

One approach to choosing the inductor is to start with the simple rule given above, look at the available inductors, and choose one to meet cost or space goals. Then use these equations to check that the LT3508 will be able to deliver the required output current. Note again that these equations assume that the inductor current is continuous. Discontinuous operation occurs when I_{OUT} is less than $\Delta I_L/2$.

Input Capacitor Selection

Bypass the V_{IN} pins of the LT3508 circuit with a ceramic capacitor of X7R or X5R type. For switching frequencies above 500kHz, use a 4.7 μ F capacitor or greater. For switching frequencies below 500kHz, use a 10 μ F or higher capacitor. If the V_{IN} pins are tied together only a single capacitor is necessary. If the V_{IN} pins are separated, each pin will need its own bypass. The following paragraphs describe the input capacitor considerations in more detail.

Step-down regulators draw current from the input supply in pulses with very fast rise and fall times. The input capacitor is required to reduce the resulting voltage ripple at the LT3508 input and to force this switching current into a tight local loop, minimizing EMI. The input capacitor must have low impedance at the switching frequency to do this effectively, and it must have an adequate ripple current rating. With two switchers operating at the same frequency but with different phases and duty cycles, calculating the input capacitor RMS current is not simple. However, a conservative value is the RMS input current for the channel that is delivering most power (V_{OUT} times I_{OUT}):

$$I_{CIN(RMS)} = I_{OUT} \cdot \frac{\sqrt{V_{OUT}(V_{IN} - V_{OUT})}}{V_{IN}} < \frac{I_{OUT}}{2}$$

and is largest when $V_{IN} = 2V_{OUT}$ (50% duty cycle). As the second, lower power channel draws input current,

3508fd

APPLICATIONS INFORMATION

the input capacitor's RMS current actually decreases as the out-of-phase current cancels the current drawn by the higher power channel. Considering that the maximum load current from a single channel is ~1.4A, RMS ripple current will always be less than 0.7A.

The high frequency of the LT3508 reduces the energy storage requirements of the input capacitor. The combination of small size and low impedance (low equivalent series resistance or ESR) of ceramic capacitors makes them the preferred choice. The low ESR results in very low voltage ripple. Ceramic capacitors can handle larger magnitudes of ripple current than other capacitor types of the same value. Use X5R and X7R types.

An alternative to a high value ceramic capacitor is a lower value ceramic along with a larger electrolytic capacitor. The electrolytic capacitor likely needs to be greater than 10μF in order to meet the ESR and ripple current requirements. The input capacitor is likely to see high surge currents when the input source is applied. Tantalum capacitors can fail due to an oversurge of current. Only use tantalum capacitors with the appropriate surge current rating. The manufacturer may also recommend operation below the rated voltage of the capacitor.

A final caution is in order regarding the use of ceramic capacitors at the input. A ceramic input capacitor can combine with stray inductance to form a resonant tank circuit. If power is applied quickly (for example by plugging the circuit into a live power source), this tank can ring, doubling the input voltage and damaging the LT3508. The solution is to either clamp the input voltage or dampen the tank circuit by adding a lossy capacitor in parallel with the ceramic capacitor. For details see Application Note 88.

Output Capacitor Selection

The output capacitor has two essential functions. Along with the inductor, it filters the square wave generated by the LT3508 to produce the DC output. In this role it determines the output ripple, and low impedance at the switching frequency is important. The second function is to store energy in order to satisfy transient loads and stabilize the

LT3508's control loop. Ceramic capacitors have very low equivalent series resistance (ESR) and provide the best ripple performance. A good value is:

$$C_{OUT} = \frac{50V}{V_{OUT}} \cdot \frac{1MHz}{f}$$

where C_{OUT} is in μF. Use X5R or X7R types. This choice will provide low output ripple and good transient response. Transient performance can be improved with a high value capacitor if the compensation network is also adjusted to maintain the loop bandwidth. A lower value of output capacitor can be used, but transient performance will suffer. With an external compensation network, the loop gain can be lowered to compensate for the lower capacitor value. Look carefully at the capacitor's data sheet to find out what the actual capacitance is under operating conditions (applied voltage and temperature). A physically larger capacitor, or one with a higher voltage rating, may be required. High performance electrolytic capacitors can be used for the output capacitor. Low ESR is important, so choose one that is intended for use in switching regulators. The ESR should be specified by the supplier, and should be 0.05Ω or less. Such a capacitor will be larger than a ceramic capacitor and will have a larger capacitance, because the capacitor must be large to achieve low ESR. Table 3 lists several capacitor vendors.

Table 3. Capacitor Vendors

VENDOR	PART SERIES	COMMENTS
Panasonic	Ceramic Polymer Tantalum	EEF Series
Kemet	Ceramic Tantalum	T494, T495
Sanyo	Ceramic Polymer Tantalum	POSCAP
Murata	Ceramic	
AVX	Ceramic Tantalum	TPS Series
Taiyo Yuden	Ceramic	
TDK	Ceramic	

APPLICATIONS INFORMATION

Diode Selection

The catch diode (D1 from Figure 1) conducts current only during switch off time. Average forward current in normal operation can be calculated from:

$$I_{D(AVG)} = \frac{I_{OUT}(V_{IN} - V_{OUT})}{V_{IN}}$$

The only reason to consider a diode with a larger current rating than necessary for nominal operation is for the worst-case condition of shorted output. The diode current will then increase to the typical peak switch current.

Peak reverse voltage is equal to the regulator input voltage. Use a diode with a reverse voltage rating greater than the input voltage. Table 4 lists several Schottky diodes and their manufacturers. If operating at high ambient temperatures, consider using a Schottky with low reverse leakage.

Table 4. Schottky Diodes

PART NUMBER	V _R (V)	I _{AVE} (A)	V _F at 1A (mV)	V _F at 2A (mV)
On Semiconductor				
MBR0520L	20	0.5		
MBR0540	40	0.5	620	
MBRM120E	20	1	530	
MBRM140	40	1	550	
Diodes Inc.				
B0530W	30	0.5		
B120	20	1	500	
B130	30	1	500	
B140HB	40	1		
DFLS140	40	1.1	510	
B240	40	2		500

BOOST Pin Considerations

The capacitor and diode tied to the BOOST pin generate a voltage that is higher than the input voltage. In most cases, a 0.22μF capacitor and fast switching diode (such as the CMDSH-3 or MMSD914LT1) will work well. For applications 1MHz or faster, a 0.1μF capacitor is sufficient. Use a 0.47μF capacitor or greater for applications running below 500kHz. Figure 4 shows three ways to arrange the boost circuit. The BOOST pin must be more than 2.5V above the SW pin for full efficiency. For outputs of 3.3V

and higher, the standard circuit (Figure 4a) is best. For outputs between 2.8V and 3.3V, use a small Schottky diode (such as the BAT-54). For lower output voltages, the boost diode can be tied to the input (Figure 4b). The circuit in Figure 4a is more efficient because the boost pin current comes from a lower voltage source. Finally, the anode of the boost diode can be tied to another source (V_{AUX}) that is at least 3V (Figure 4c). For example, if you are generating a 3.3V output, and the 3.3V output is on whenever the particular channel is on, the anode of the BOOST diode can be connected to the 3.3V output. In any case, be sure that the maximum voltage at the BOOST pin is both less than 60V and the voltage difference between the BOOST and SW pins is less than 30V.

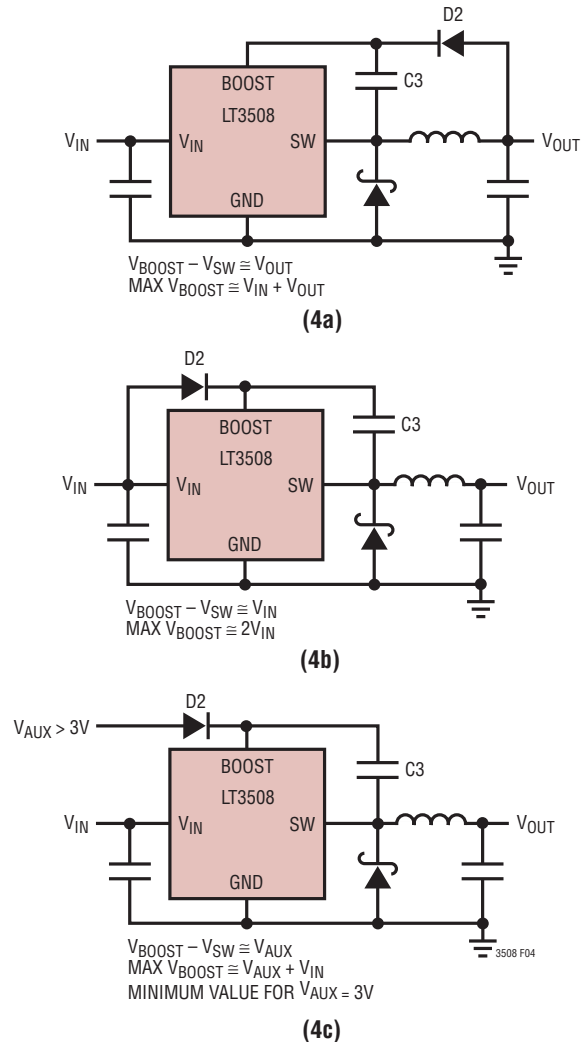

Figure 4. Generating the Boost Voltage

APPLICATIONS INFORMATION

The minimum operating voltage of an LT3508 application is limited by the undervoltage lockout ($\approx 3.7V$) and by the maximum duty cycle. The boost circuit also limits the minimum input voltage for proper start-up. If the input voltage ramps slowly, or the LT3508 turns on when the output is already in regulation, the boost capacitor may not be fully charged. Because the boost capacitor charges with the energy stored in the inductor, the circuit will rely on some minimum load current to get the boost circuit running properly. This minimum load will depend on input and output voltages, and on the arrangement of the boost circuit. The minimum load current generally goes to zero once the circuit has started. Figure 5 shows a plot of minimum load to start and to run as a function of input voltage. Even without an output load current, in

many cases the discharged output capacitor will present a load to the switcher that will allow it to start. The plots show the worst case, where V_{IN} is ramping very slowly.

Frequency Compensation

The LT3508 uses current mode control to regulate the output. This simplifies loop compensation. In particular, the LT3508 does not require the ESR of the output capacitor for stability, so you are free to use ceramic capacitors to achieve low output ripple and small circuit size.

Frequency compensation is provided by the components tied to the V_C pin, as shown in Figure 1. Generally a capacitor (C_C) and a resistor (R_C) in series to ground are used. In addition, there may be a lower value capacitor in parallel. This capacitor (C_F) is not part of the loop compensation but is used to filter noise at the switching frequency, and is required only if a phase-lead capacitor is used or if the output capacitor has high ESR.

Loop compensation determines the stability and transient performance. Designing the compensation network is a bit complicated and the best values depend on the application and in particular the type of output capacitor. A practical approach is to start with one of the circuits in this data sheet that is similar to your application and tune the compensation network to optimize the performance. Stability should then be checked across all operating conditions, including load current, input voltage and temperature. The LT1375 data sheet contains a more thorough discussion of loop compensation and describes how to test the stability using a transient load.

Figure 6 shows an equivalent circuit for the LT3508 control loop. The error amplifier is a transconductance amplifier with finite output impedance. The power section, consisting of the modulator, power switch and inductor, is modeled as a transconductance amplifier generating an output current proportional to the voltage at the V_C pin. Note that the output capacitor integrates this current, and that the capacitor on the V_C pin (C_C) integrates the error amplifier output current, resulting in two poles in the loop. In most cases a zero is required and comes from either the output capacitor ESR or from a resistor R_C in series with C_C . This simple model works well as long as the value of the inductor is not too high and the loop crossover frequency

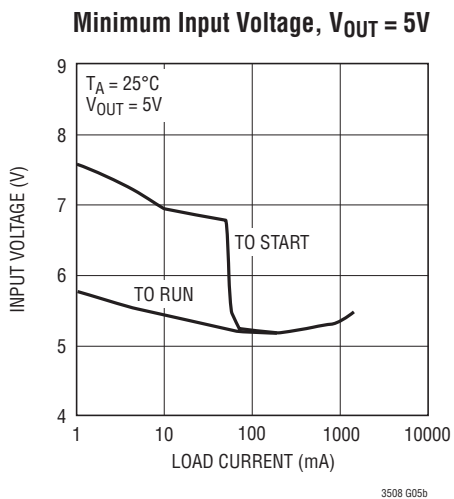
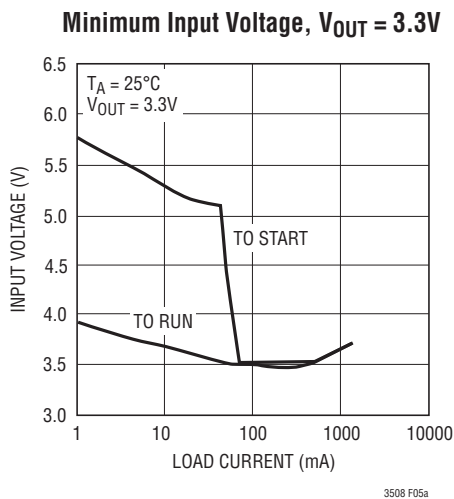

Figure 5. The Minimum Input Voltage Depends on Output Voltage, Load Current and Boost Circuit

APPLICATIONS INFORMATION

is much lower than the switching frequency. A phase-lead capacitor (C_{PL}) across the feedback divider may improve the transient response.

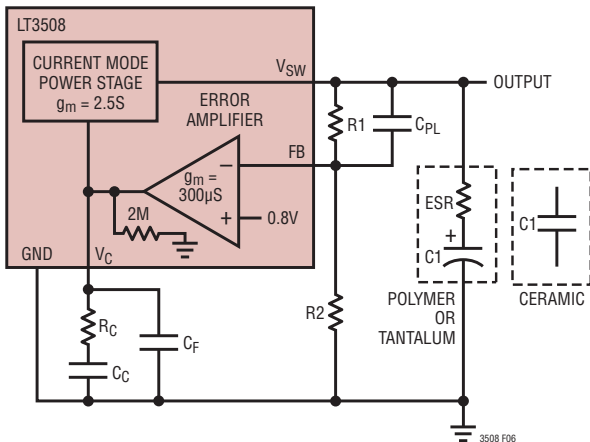

Figure 6. Model for Loop Response

Shutdown and Undervoltage Lockout

Figure 7 shows how to add undervoltage lockout (UVLO) to the LT3508. Typically, UVLO is used in situations where the input supply is current limited, or has a relatively high source resistance. A switching regulator draws constant power from the source, so source current increases as source voltage drops. This looks like a negative resistance load to the source and can cause the source to current limit or latch low under low source voltage conditions. UVLO prevents the regulator from operating at source voltages where the problems might occur.

An internal comparator will force the part into shutdown below the minimum V_{IN1} of 3.7V. This feature can be used to prevent excessive discharge of battery-operated systems.

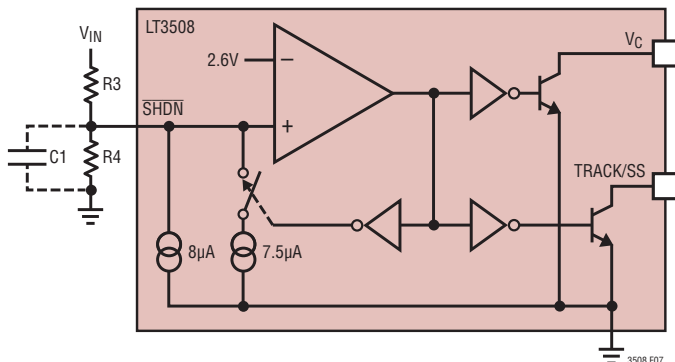

Figure 7. Undervoltage Lockout

If an adjustable UVLO threshold is required, the $\overline{\text{SHDN}}$ pin can be used. The threshold voltage of the $\overline{\text{SHDN}}$ pin comparator is 2.63V. Current hysteresis is added above the $\overline{\text{SHDN}}$ threshold. This can be used to set voltage hysteresis of the UVLO using the following:

$$R3 = \frac{V_H - V_L}{7.5\mu\text{A}}$$

$$R4 = \frac{2.63\text{V}}{\frac{V_L - 2.63\text{V}}{R3} - 8\mu\text{A}}$$

Example: switching should not start until the input is above 4.75V and is to stop if the input falls below 4V.

$$V_H = 4.75\text{V}, V_L = 4.0\text{V}$$

$$R3 = \frac{4.75\text{V} - 4\text{V}}{7.5\mu\text{A}} = 100\text{k}$$

$$R4 = \frac{2.63\text{V}}{\frac{4\text{V} - 2.63\text{V}}{100\text{k}} - 8\mu\text{A}} = 461\text{k}$$

Keep the connection from the resistor to the $\overline{\text{SHDN}}$ pin short and make sure the interplane or surface capacitance to switching nodes is minimized. If high resistor values are used, the $\overline{\text{SHDN}}$ pin should be bypassed with a 1nF capacitor to prevent coupling problems from the switch node.

Soft-Start

The output of the LT3508 regulates to the lowest voltage present at either the TRACK/SS pin or an internal 0.8V reference. A capacitor from the TRACK/SS pin to ground is charged by an internal 1.2µA current source resulting in a linear output ramp from 0V to the regulated output whose duration is given by:

$$t_{\text{RAMP}} = \frac{C_{\text{SS}} \cdot 0.8\text{V}}{1.2\mu\text{A}}$$

At power up, internal open-collector outputs discharge both TRACK/SS pins. The pins clamp at 1.3V.

APPLICATIONS INFORMATION

Output Tracking and Sequencing

Complex output tracking and sequencing between channels can be implemented using the LT3508's TRACK/SS and PG pins. Figure 8 shows several configurations for output tracking and sequencing of 5V and 3.3V applications.

Independent soft-start for each channel is shown in Figure 8a. The output ramp time for each channel is set by the soft-start capacitor as described in the soft-start section.

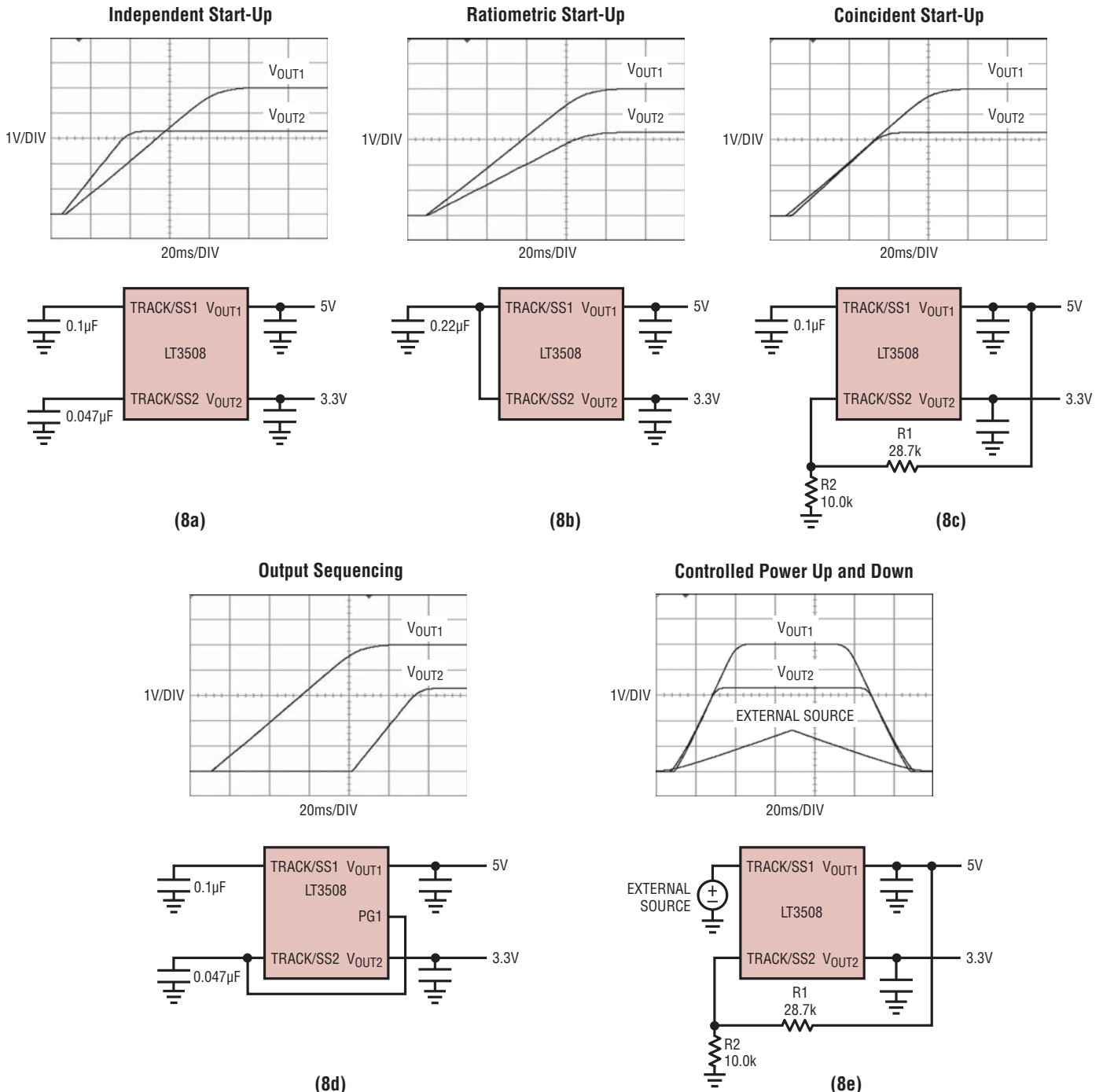

Figure 8

APPLICATIONS INFORMATION

Ratiometric tracking is achieved in Figure 8b by connecting both the TRACK/SS pins together. In this configuration the TRACK/SS pin source current is doubled ($2.4\mu\text{A}$) which must be taken into account when calculating the output rise time.

Do not tie TRACK/SS1 and TRACK/SS2 together if using multiple inputs. If $V_{\text{IN}2}$ is below 3V, TRACK/SS2 pulls low and would hold TRACK/SS1 low as well if the two pins are tied together, which would prevent channel 1 from operating.

By connecting a feedback network from $V_{\text{OUT}1}$ to the TRACK/SS2 pin with the same ratio that set the $V_{\text{OUT}2}$ voltage, absolute tracking shown in Figure 8c is implemented. A small $V_{\text{OUT}2}$ voltage offset will be present due to the TRACK/SS2 $1.2\mu\text{A}$ source current. This offset can be corrected for by slightly reducing the value of R2. Use a resistor divider such that when $V_{\text{OUT}1}$ is in regulation, TRACK/SS2 is pulled up to 1V or greater. If TRACK/SS is below 1V, the output may regulate FB to a voltage lower than the 800mV reference voltage.

Figure 8d illustrates output sequencing. When $V_{\text{OUT}1}$ is within 10% of its regulated voltage, PG1 releases the TRACK/SS2 soft-start pin allowing $V_{\text{OUT}2}$ to soft-start. In this case PG1 will be pulled up to 1.3V by the TRACK/SS pin.

If precise output ramp up and down is required, drive the TRACK/SS pins as shown in Figure 8e.

Multiple Inputs

For applications requiring large inductors due to high V_{IN} to V_{OUT} ratios, a 2-stage step down approach may reduce inductor size by allowing an increase in frequency. A dual step-down application (Figure 9) steps down the input voltage ($V_{\text{IN}1}$) to the highest output voltage, then uses that voltage to power the second output ($V_{\text{IN}2}$). $V_{\text{OUT}1}$ must be able to provide enough current for its output plus the input current at $V_{\text{IN}2}$ when $V_{\text{OUT}2}$ is at its maximum load.

For applications with multiple input voltages, the LT3508 can accommodate input voltages as low as 3V on $V_{\text{IN}2}$. This can be useful in applications regulating outputs from a PCI Express bus, where the 12V input is power limited and the 3.3V input has power available to drive other outputs. In this case, tie the 12V input to $V_{\text{IN}1}$ and the 3.3V input to $V_{\text{IN}2}$. See the Typical Application section for an example circuit.

Shorted and Reverse Input Protection

If the inductor is chosen so that it won't saturate excessively, an LT3508 step-down regulator will tolerate a shorted output. There is another situation to consider in systems where the output will be held high when the input to the

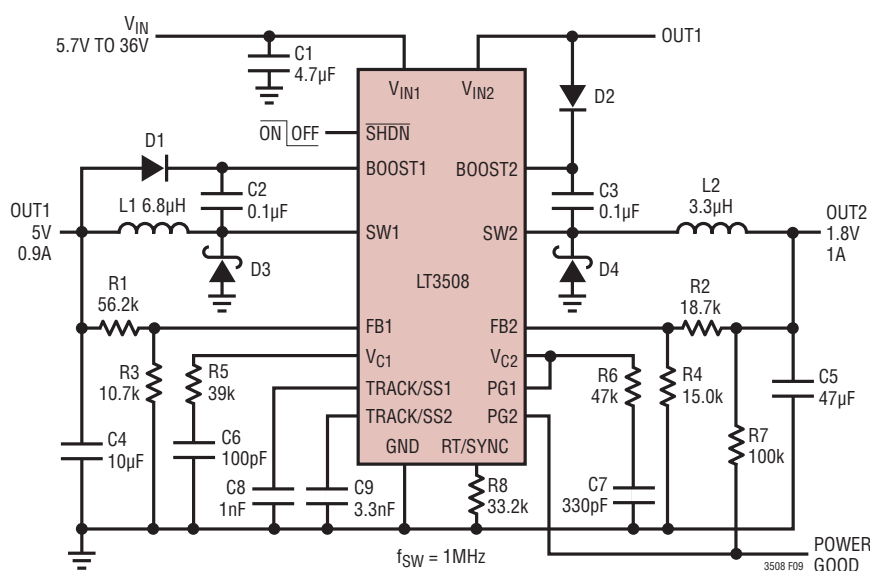

Figure 9. 1MHz, Wide Input Range 5V and 1.8V Outputs

APPLICATIONS INFORMATION

LT3508 is absent. This may occur in battery charging applications or in battery back-up systems where a battery or some other supply is diode OR-ed with the LT3508's output. If the V_{IN} pin is allowed to float and the \overline{SHDN} pin is held high (either by a logic signal or because it is tied to V_{IN}), then the LT3508's internal circuitry will pull its quiescent current through its SW pin. This is fine if your system can tolerate a few mA in this state. If you ground the \overline{SHDN} pin, the SW pin current will drop to essentially zero. However, if the V_{IN} pin is grounded while the output is held high, then parasitic diodes inside the LT3508 can pull large currents from the output through the SW pin and the V_{IN} pin. Figure 10 shows a circuit that will run only when the input voltage is present and that protects against a shorted or reversed input.

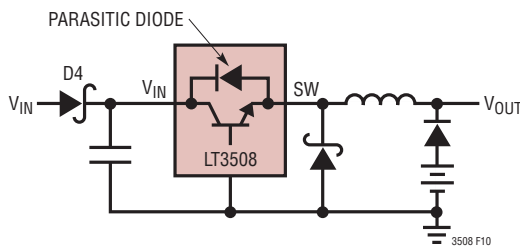
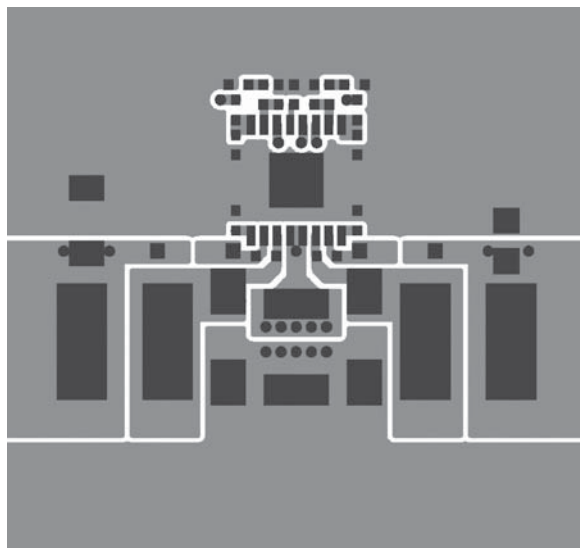

Figure 10. Diode D4 Prevents a Shorted Input from Discharging a Backup Battery Tied to the Output

PCB Layout

For proper operation and minimum EMI, care must be taken during printed circuit board layout. Figure 11 shows the recommended PCB layout with trace and via locations. Note that large, switched currents flow in the LT3508's V_{IN} and SW pins, the catch diode (D1) and the input capacitor (C_{IN}). The loop formed by these components should be as small as possible. These components, along with the inductor and output capacitor, should be placed on the same side of the circuit board, and their connections should be made on that layer. Place a local, unbroken ground plane below these components. The SW and BOOST nodes should be as small as possible. Finally, keep the FB and V_C nodes small so that the ground traces will shield them from the SW and BOOST nodes. The exposed pad on the bottom of the package must be soldered to ground so that the pad acts as a heat sink. To keep thermal resistance low, extend the ground plane as much as possible, and add thermal vias under and near the LT3508 to additional ground planes within the circuit board and on the bottom side.



(11a) Example Layout for FE16 Package

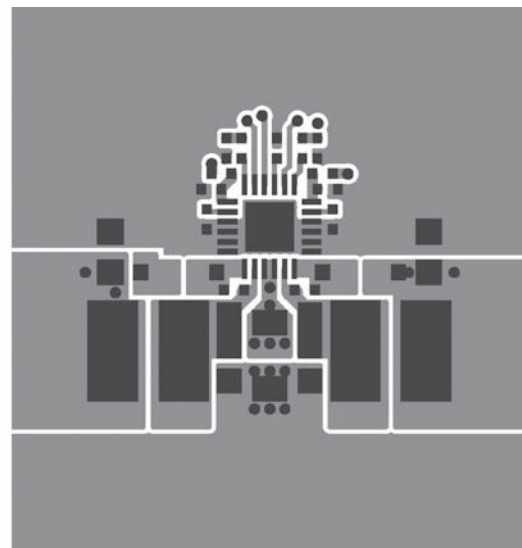

(11b) Example Layout for QFN Package

Figure 11. A Good PCB Layout Ensures Proper Low EMI Operation

APPLICATIONS INFORMATION

High Temperature Considerations

The die temperature of the LT3508 must be lower than the maximum rating of 125°C (150°C for the H-grade). This is generally not a concern unless the ambient temperature is above 85°C. For higher temperatures, care should be taken in the layout of the circuit to ensure good heat sinking of the LT3508. The maximum load current should be derated as the ambient temperature approaches 125°C (150°C for the H-grade). The die temperature is calculated by multiplying the LT3508 power dissipation by the thermal resistance from junction to ambient. Power dissipation within the LT3508 can be estimated by calculating the total power loss from an efficiency measurement and subtracting the catch diode loss. Thermal resistance depends on the layout of the circuit board, but values from 30°C/W to 60°C/W are typical. Die temperature rise was measured on a 4-layer, 6.5cm × 7.5cm circuit board in still air at a load current of 1.4A ($f_{SW} = 700\text{kHz}$). For a 12V input to 3.3V output the die temperature elevation above ambient

was 13°C; for 24V_{IN} to 3.3V_{OUT} the rise was 18°C; for 12V_{IN} to 5V_{OUT} the rise was 14°C and for 24V_{IN} to 5V_{OUT} the rise was 19°C.

Outputs Greater Than 6V

For outputs greater than 6V, add a resistor of 1k to 2.5k across the inductor to damp the discontinuous ringing of the SW node, preventing unintended SW current. The 12V output circuit in the Typical Applications section shows the location of this resistor.

Other Linear Technology Publications

Application Notes 19, 35 and 44 contain more detailed descriptions and design information for step-down regulators and other switching regulators. The LT1376 data sheet has a more extensive discussion of output ripple, loop compensation and stability testing. Design Note 318 shows how to generate a dual polarity output supply using a step-down regulator.

TYPICAL APPLICATIONS

1MHz, 3.3V and 1.8V Outputs with Sequencing

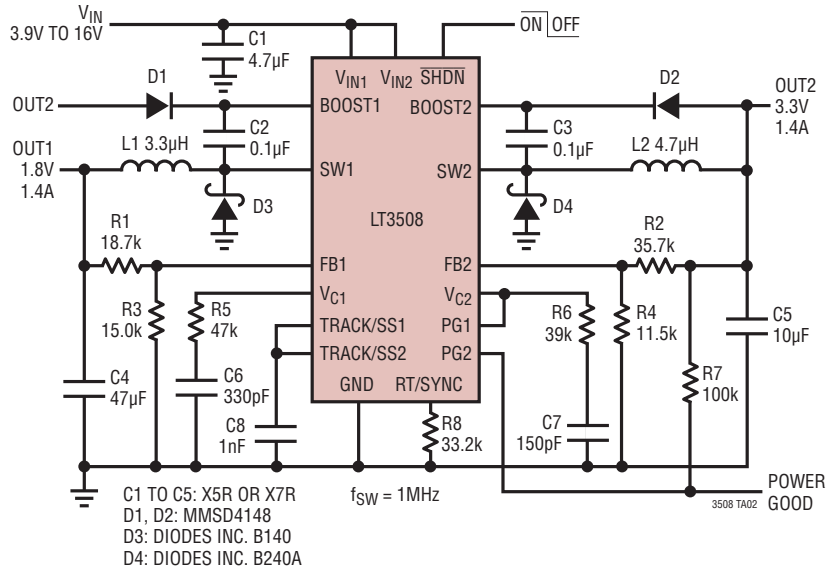

3.3V and 5V Dual Output Step-Down Converter with Output Sequencing

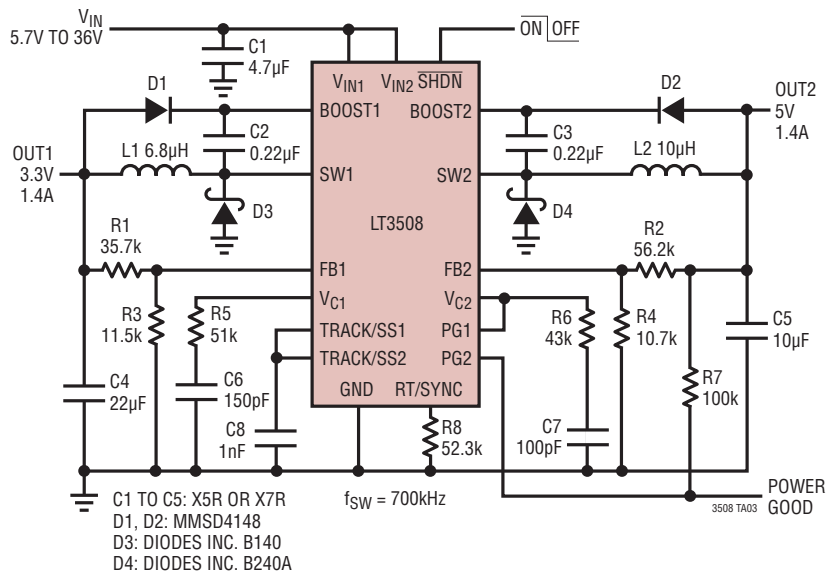

TYPICAL APPLICATIONS

1MHz, Wide Input Range 5V and 1.8V Outputs

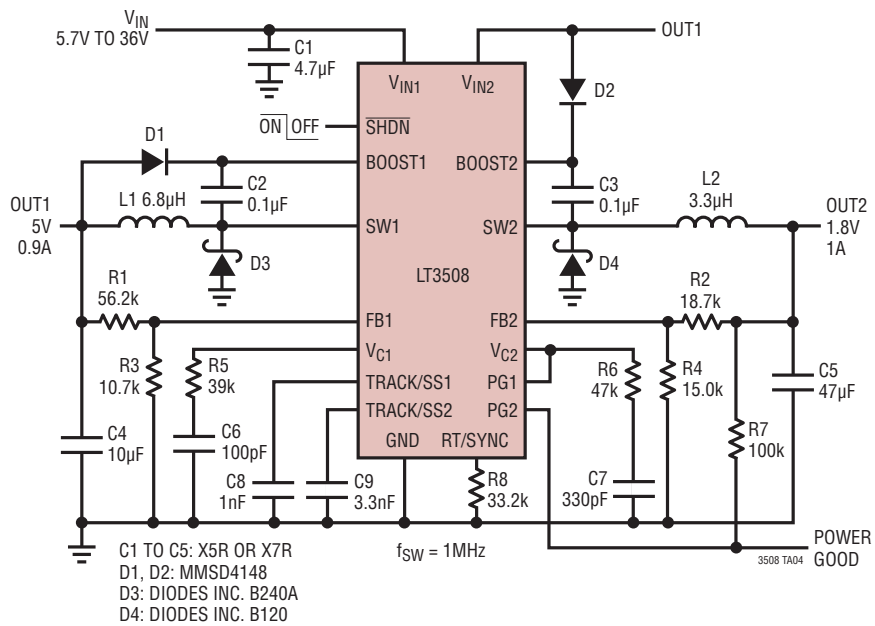

TYPICAL APPLICATIONS

1MHz, 5V and 12V Outputs

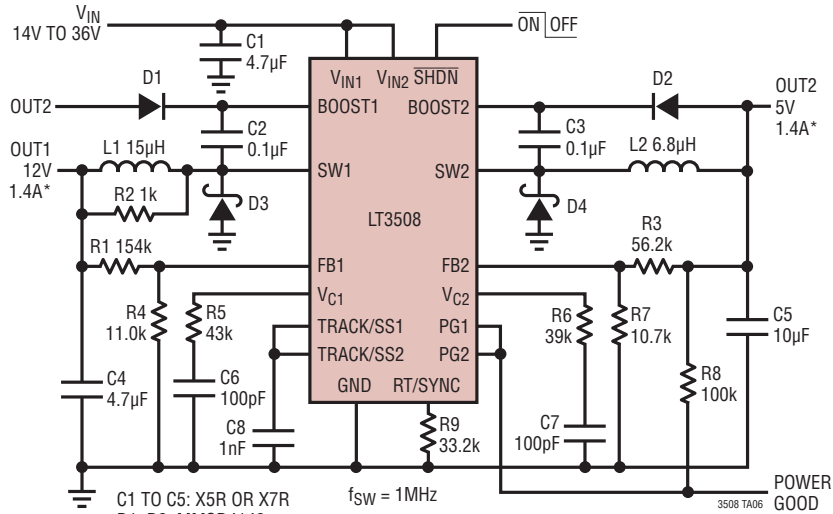

- C1 TO C5: X5R OR X7R
- D1, D2: MMSD4148
- D3: DIODES INC. B240A
- D4: DIODES INC. B140
- R2: USE 0.25W RESISTOR. FOR CONTINUOUS OPERATION ABOVE 30V, USE TWO 2k, 0.25W RESISTORS IN PARALLEL
- *DERATE OUTPUT CURRENT AT HIGHER AMBIENT TEMPERATURES AND INPUT VOLTAGES TO MAINTAIN JUNCTION TEMPERATURE BELOW THE ABSOLUTE MAXIMUM

PACKAGE DESCRIPTION

Please refer to <http://www.linear.com/designtools/packaging/> for the most recent package drawings.

FE Package
16-Lead Plastic TSSOP (4.4mm)
 (Reference LTC DWG # 05-08-1663 Rev I)
Exposed Pad Variation BA

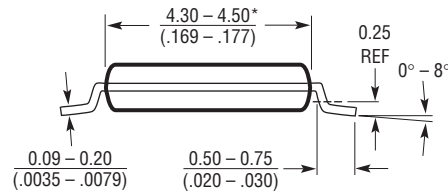
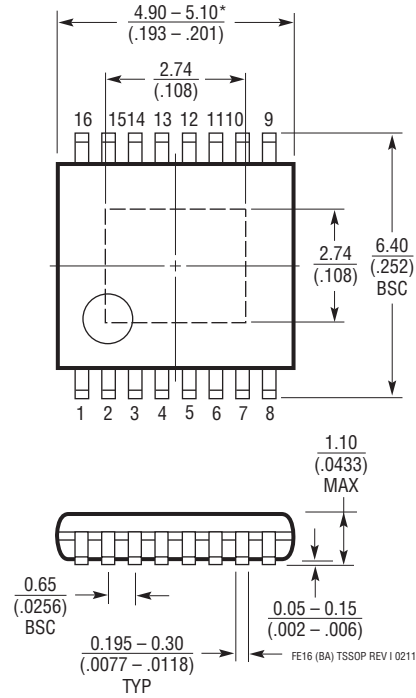
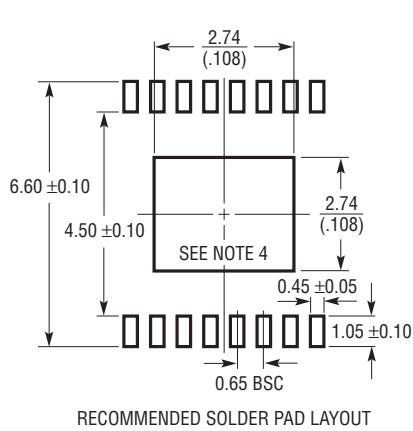

- NOTE:
1. CONTROLLING DIMENSION: MILLIMETERS
 2. DIMENSIONS ARE IN MILLIMETERS (INCHES)
 3. DRAWING NOT TO SCALE
 4. RECOMMENDED MINIMUM PCB METAL SIZE FOR EXPOSED PAD ATTACHMENT
- *DIMENSIONS DO NOT INCLUDE MOLD FLASH. MOLD FLASH SHALL NOT EXCEED 0.150mm (.006") PER SIDE

PACKAGE DESCRIPTION

Please refer to <http://www.linear.com/designtools/packaging/> for the most recent package drawings.

UF Package
24-Lead Plastic QFN (4mm × 4mm)
 (Reference LTC DWG # 05-08-1697)

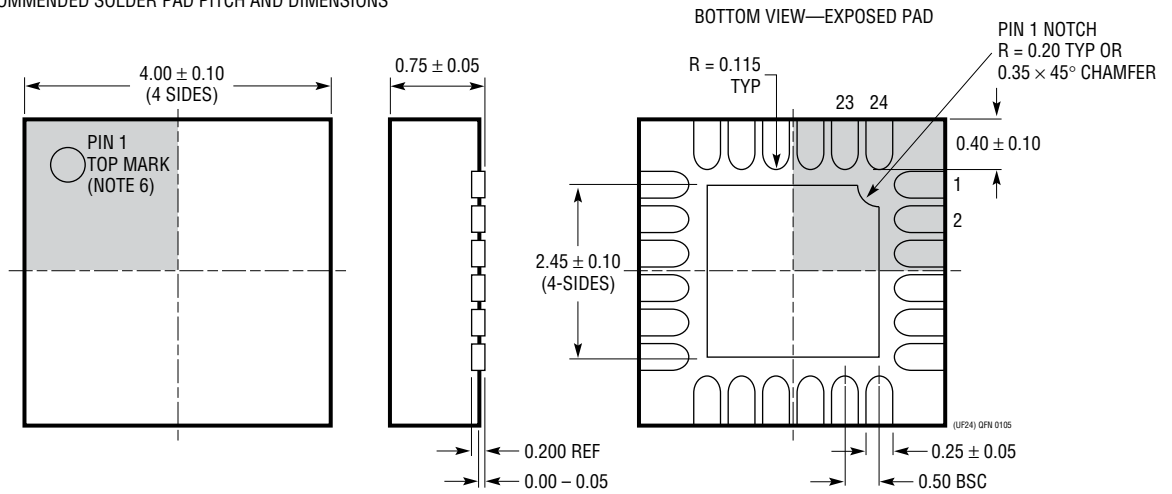
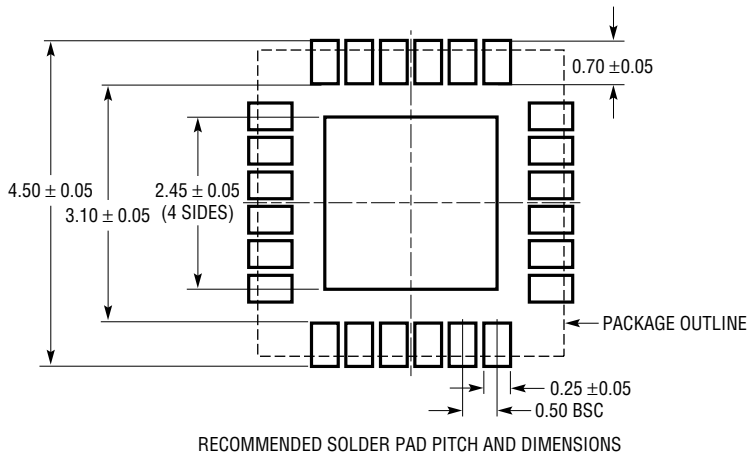

REVISION HISTORY (Revision history begins at Rev D)

REV	DATE	DESCRIPTION	PAGE NUMBER
D	8/11	Revised Typical Application drawing TA01a Changed R _T /SYNC pin name to RT/SYNC	1 1, 2, 6, 7, 8, 10, 17, 20, 21, 22, 26
		Updated Pin Configuration drawings	2
		Revised Exposed Pad, V _{C1} , V _{C2} and V _{IN1} pin descriptions in Pin Functions section	6
		Made minor text edits in Operation and Applications Information sections	8, 10
		Updated equations in Input Capacitor and Shutdown and Undervoltage Lockout sections and revised Figure 4 of Applications Information	11, 13, 15
		Moved last paragraph of Multiple Inputs section to the Soft-Start section in Applications Information	17

TYPICAL APPLICATION

5V, 1.8V Output from PCI Express

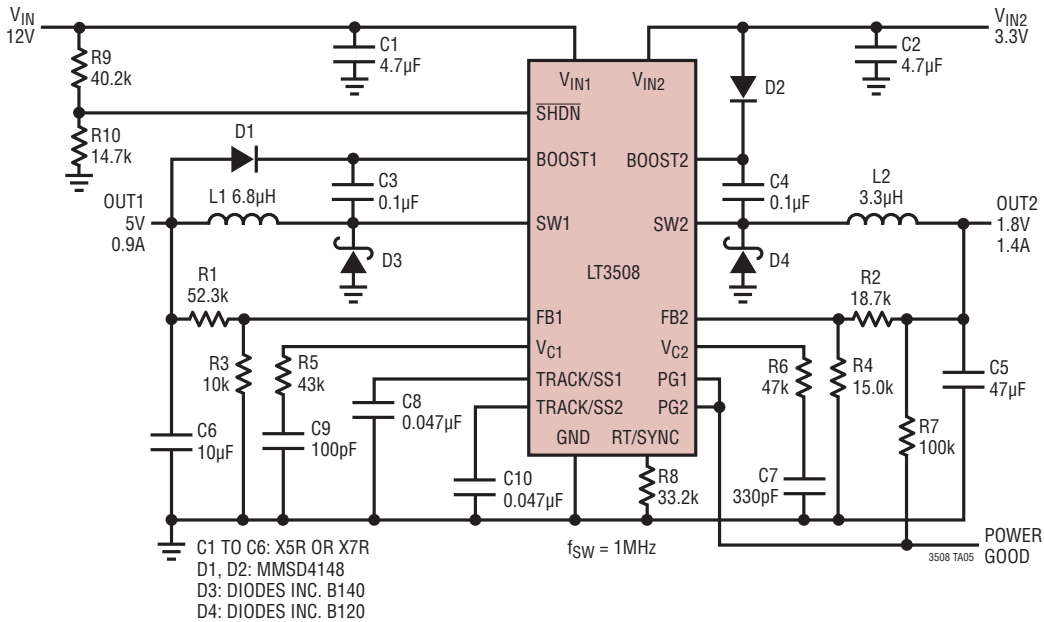

RELATED PARTS

PART NUMBER	DESCRIPTION	COMMENTS
LT1765	25V, 2.75A (I_{OUT}), 1.25MHz, High Efficiency Step-Down DC/DC Converter	V_{IN} : 3V to 25V, $V_{OUT(MIN)}$ = 1.2V, I_Q = 1mA, S8, TSSOP16E Packages
LT1766	60V, 1.2A (I_{OUT}), 200kHz, High Efficiency Step-Down DC/DC Converter	V_{IN} : 5.5V to 60V, $V_{OUT(MIN)}$ = 1.2V, I_Q = 2.5mA, TSSOP16/TSSOP16E Packages
LT1767	25V, 1.2A (I_{OUT}), 1.25MHz, High Efficiency Step-Down DC/DC Converter	V_{IN} : 3V to 25V, $V_{OUT(MIN)}$ = 1.2V, I_Q = 1mA, MS8, MS8E Packages
LT1940/LT1940L	Dual Monolithic 1.4A, 1.1MHz Step-Down Switching Regulators	V_{IN} : 3.6V to 25V, $V_{OUT(MIN)}$ = 1.25V, I_Q = 3.8mA, TSSOP16E Packages
LTC3407	Dual 600mA, 1.5MHz, Synchronous Step-Down Regulator	V_{IN} : 2.5V to 5.5V, $V_{OUT(MIN)}$ = 0.6V, I_Q = 40µA, MSE Package
LT3493	1.2A, 750kHz Step-Down Switching Regulator in 2mm × 3mm DFN	V_{IN} : 3.6V to 36V, $V_{OUT(MIN)}$ = 0.78V, I_Q = 1.9mA, 2mm × 3mm DFN Package
LT3501/LT3510	Dual 3A/2A, 1.5MHz High Efficiency Step-Down Switching Regulators	V_{IN} : 3.6V to 25V, $V_{OUT(MIN)}$ = 0.8V, I_Q = 3.7mA, $I_{SD} < 10\mu\text{A}$, TSSOP20E Package
LT3506/LT3506A	Dual Monolithic 1.6A, 1.1MHz Step-Down Switching Regulators	V_{IN} : 3.6V to 25V, $V_{OUT(MIN)}$ = 0.8V, I_Q = 3.8mA, 16-Lead DFN and 16-Lead TSSOP20E Packages
LTC3701	Two Phase, Dual, 500kHz, Constant Frequency, Current Mode, High Efficiency Step-Down DC/DC Controller	V_{IN} : 2.5V to 10V, $V_{OUT(MIN)}$ = 0.8V, I_Q = 460µA, SSOP-16 Package
LTC3736	Dual Two Phase, No R_{SENSE}^{TM} , Synchronous Controller with Output Tracking	V_{IN} : 2.75V to 9.8V, $V_{OUT(MIN)}$ = 0.6V, I_Q = 300µA, 4mm × 4mm QFN or SSOP-24 Packages
LTC3737	Dual Two Phase, No R_{SENSE} DC/DC Controller with Output Tracking	V_{IN} : 2.75V to 9.8V, $V_{OUT(MIN)}$ = 0.6V, I_Q = 220µA, 4mm × 4mm QFN or SSOP-24 Packages

Looking for pricing, stock, or lifecycle information?

Click below to explore more details on WIN SOURCE:

 [View LT3508HFE#PBF on WIN SOURCE](#)

 [Linear Technology](#) Information

Optimize Your Supply Chain with WIN SOURCE Solutions

-  Global Sourcing Solution
-  Obsolete Management
-  Cost Control Management
-  Shortage Management
-  Alternative Solution
-  Excess Inventory Management