



**THE DATASHEET OF
LT8410EDC#TRPBF**



Ultralow Power Boost Converter with Output Disconnect

FEATURES

- **Ultralow Quiescent Current**
8.5 μ A in Active Mode
0 μ A in Shutdown Mode
- **Comparator Built into $\overline{\text{SHDN}}$ Pin**
- **Low Noise Control Scheme**
- **Adjustable FB Reference Voltage**
- **Wide Input Range: 2.5V to 16V**
- **Wide Output Range: Up to 40V**
- **Integrated Power NPN Switch**
25mA Current Limit (LT8410)
8mA Current Limit (LT8410-1)
- **Integrated Schottky Diode**
- **Integrated Output Disconnect**
- **High Value (12.4M/0.4M) Feedback Resistors Integrated**
- **Built in Soft-Start (Optional Capacitor from V_{REF} to GND)**
- **Overvoltage Protection for CAP and V_{OUT} Pins**
- **Tiny 8-Pin 2mm \times 2mm DFN Package**

APPLICATIONS

- Sensor Power
- RF Mems Relay Power
- General Purpose Bias

DESCRIPTION

The **LT[®]8410/LT8410-1** are ultralow power boost converters with integrated power switch, Schottky diode and output disconnect circuitry. The parts control power delivery by varying both the peak inductor current and switch off-time. This control scheme results in low output voltage ripple as well as high efficiency over a wide load range. The quiescent current is a low 8.5 μ A, which is further reduced to 0 μ A in shutdown. The internal disconnect circuitry allows the output voltage to be blocked from the input during shutdown. High value (12.4M/0.4M) resistors are integrated on chip for output voltage detection, significantly reducing input referred quiescent current. The **LT8410/LT8410-1** also features a comparator built into the $\overline{\text{SHDN}}$ pin, overvoltage protection for the CAP and V_{OUT} pins, built in soft-start and comes in a tiny 8-pin 2mm \times 2mm DFN package.

LT, LT, LTC, LTM, Linear Technology and the Linear logo are registered trademarks of Linear Technology Corporation. All other trademarks are the property of their respective owners. Protected by U.S. Patents, including 5481178, 6580258, 6304066, 6127815, 6498466, 6611131.

TYPICAL APPLICATION

General Purpose Bias with Wide Input Voltage

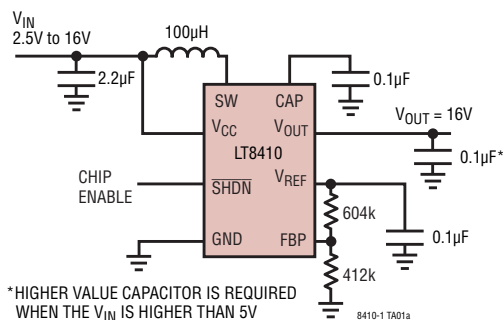

Output Voltage Ripple vs Load Current

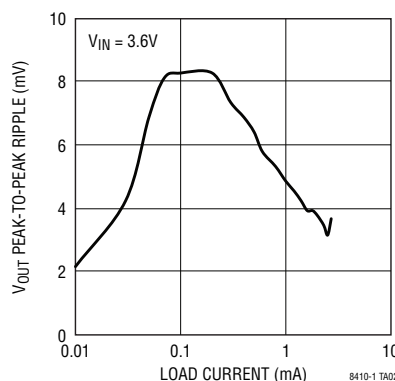

Efficiency vs Load Current

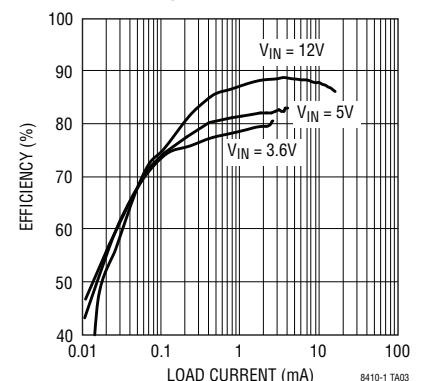

LT8410/LT8410-1

ABSOLUTE MAXIMUM RATINGS

(Note 1)

V_{CC} Voltage	-0.3V to 16V
SW Voltage	-0.3V to 42V
CAP Voltage	-0.3V to 40V
V_{OUT} Voltage	-0.3V to 40V
SHDN Voltage	-0.3V to 16V
V_{REF} Voltage	-0.3V to 2.5V
FBP Voltage	-0.3V to 2.5V
Maximum Junction Temperature	125°C
Operating Temperature Range (Note 2) ..	-40°C to 125°C
Storage Temperature Range	-65°C to 150°C

PIN CONFIGURATION

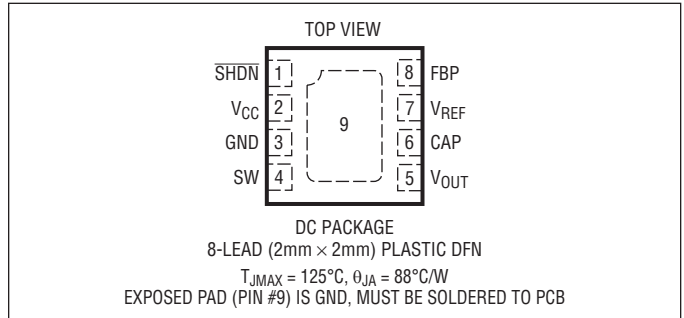

ORDER INFORMATION

(<http://www.linear.com/product/LT8410#orderinfo>)

LEAD FREE FINISH	TAPE AND REEL	PART MARKING*	PACKAGE DESCRIPTION	TEMPERATURE RANGE
LT8410EDC#PBF	LT8410EDC#TRPBF	LDQR	8-Lead (2mm × 2mm) Plastic DFN	-40°C to 125°C
LT8410IDC#PBF	LT8410IDC#TRPBF	LDQR	8-Lead (2mm × 2mm) Plastic DFN	-40°C to 125°C
LT8410EDC-1#PBF	LT8410EDC-1#TRPBF	LFCC	8-Lead (2mm × 2mm) Plastic DFN	-40°C to 125°C
LT8410IDC-1#PBF	LT8410IDC-1#TRPBF	LFCC	8-Lead (2mm × 2mm) Plastic DFN	-40°C to 125°C

Consult LTC Marketing for parts specified with wider operating temperature ranges. *The temperature grade is identified by a label on the shipping container.

For more information on lead free part marking, go to: <http://www.linear.com/leadfree/>

For more information on tape and reel specifications, go to: <http://www.linear.com/tapeandreeel/>. Some packages are available in 500 unit reels through designated sales channels with #TRMPBF suffix.

ELECTRICAL CHARACTERISTICS

The ● denotes the specifications which apply over the full operating temperature range, otherwise specifications are at $T_A = 25^\circ\text{C}$. $V_{CC} = 3\text{V}$, $V_{SHDN} = V_{CC}$ unless otherwise noted. (Note 2)

PARAMETER	CONDITIONS	MIN	TYP	MAX	UNITS
Minimum Operating Voltage			2.2	2.5	V
Maximum Operating Voltage				16	V
Reference Voltage		● 1.220	1.235	1.255	V
V_{REF} Current Limit	(Note 3)		10		μA
V_{REF} Discharge Time			70		μS
V_{REF} Line Regulation			0.01		%/V
Quiescent Current	Not Switching	●	8.5	12	μA
Quiescent Current in Shutdown	$V_{SHDN} = 0\text{V}$	●	0	1	μA
Quiescent Current from V_{OUT} and CAP	$V_{OUT} = 16\text{V}$		3		μA
Minimum Switch Off Time	After Start-Up (Note 4) During Start-Up (Note 4)		240 600		nS nS
Switch Current Limit	LT8410	● 20	25	30	mA
	LT8410-1	● 6	8	10	mA

84101fc

ELECTRICAL CHARACTERISTICS

The ● denotes the specifications which apply over the full operating temperature range, otherwise specifications are at $T_A = 25^\circ\text{C}$. $V_{CC} = 3\text{V}$, $V_{SHDN} = V_{CC}$ unless otherwise noted. (Note 2)

PARAMETER	CONDITIONS	MIN	TYP	MAX	UNITS
Switch V_{CESAT}	LT8410, $I_{SW} = 10\text{mA}$ LT8410-1, $I_{SW} = 4\text{mA}$		150 100		mV mV
Switch Leakage Current	$V_{SW} = 5\text{V}$		0	1	μA
Schottky Forward Voltage	$I_{DIODE} = 10\text{mA}$		650	850	mV
Schottky Reverse Leakage	$V_{CAP} - V_{SW} = 5$ $V_{CAP} - V_{SW} = 40$		0 0	0.5 1	μA μA
PMOS Disconnect Current Limit	LT8410 LT8410-1	14 2.5	19 4	25 5	mA mA
PMOS Disconnect $V_{CAP} - V_{OUT}$	$I_{OUT} = 1\text{mA}$		50		mV
V_{OUT} Resistor Divider Ratio		● 31.6	31.85	32.2	
FBP Pin Bias Current	$V_{FBP} = 0.5\text{V}$, Current Flows Out of Pin	●	1.3	30	nA
SHDN Minimum Input Voltage High	SHDN Rising	● 1.20	1.30	1.45	V
SHDN Input Voltage High Hysteresis			60		mV
SHDN Hysteresis Current	(Note 3)	0.08	0.1	0.14	μA
SHDN Input Voltage Low				0.3	V
SHDN Pin Bias Current	$V_{SHDN} = 3\text{V}$ $V_{SHDN} = 16\text{V}$		0 2	1 3	μA μA

Note 1: Stresses beyond those listed under Absolute Maximum Ratings may cause permanent damage to the device. Exposure to any Absolute Maximum Rating condition for extended periods may affect device reliability and lifetime.

Note 2: The LT8410E/LT8410E-1 are guaranteed to meet performance specifications from 0°C to 125°C junction temperature. Specifications over the -40°C to 125°C operating junction temperature range are assured by design, characterization and correlation with statistical process controls. The LT8410I/LT8410I-1 are guaranteed over the full -40°C to 125°C operating junction temperature range.

Note 3: See the Applications Information section for more information.

Note 4: Start-up mode occurs when V_{OUT} is less than $V_{FBP} \cdot 64/3$.

TYPICAL PERFORMANCE CHARACTERISTICS

$T_A = 25^\circ\text{C}$, unless otherwise noted.

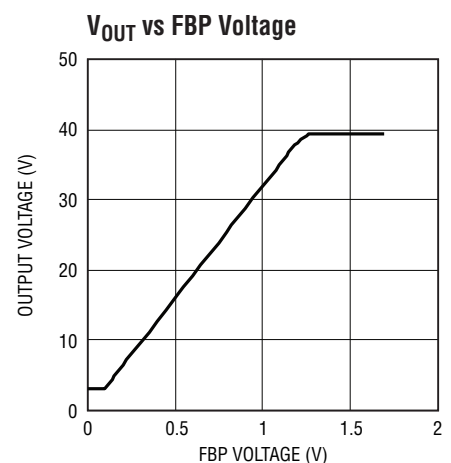
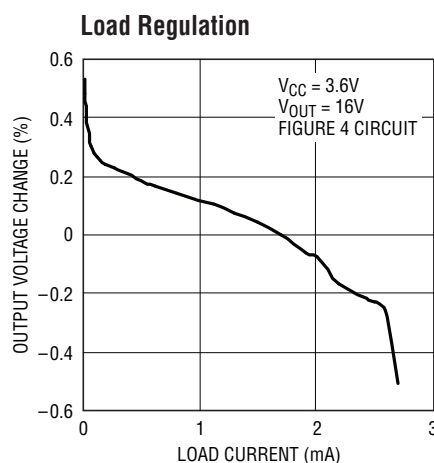
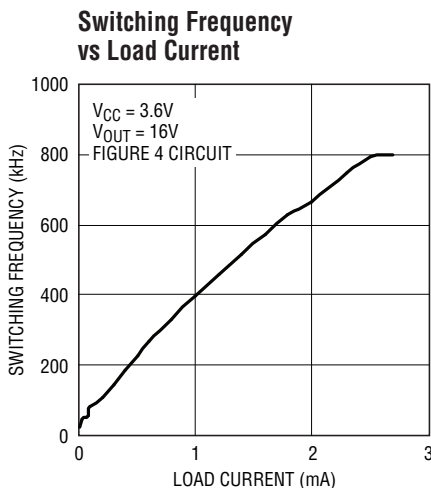

TYPICAL PERFORMANCE CHARACTERISTICS

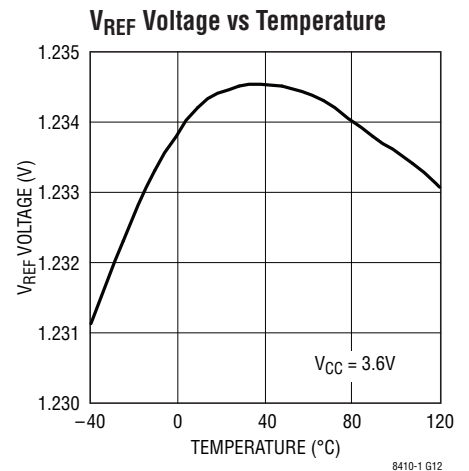
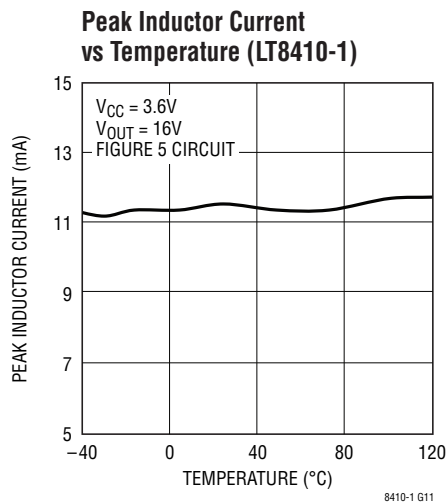
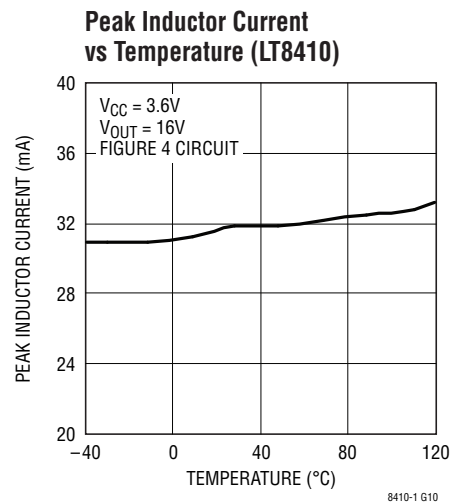
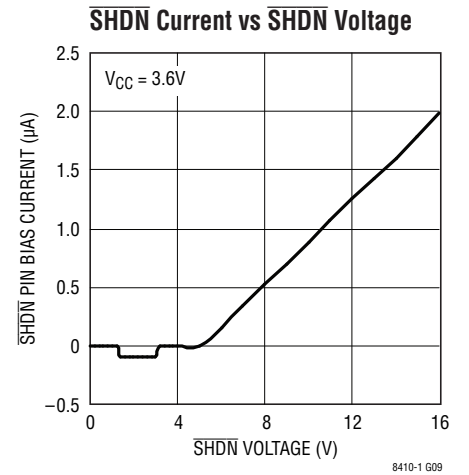
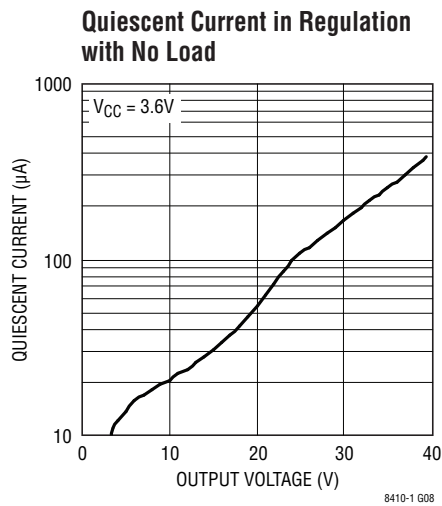
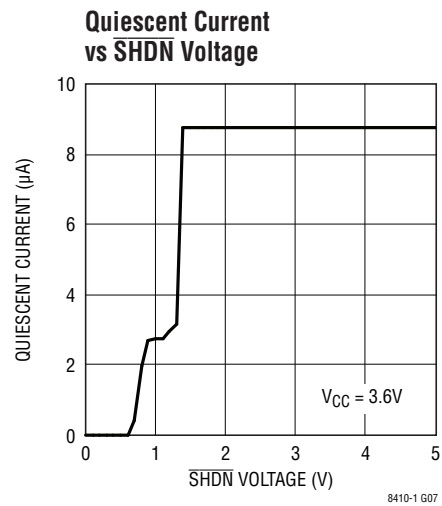
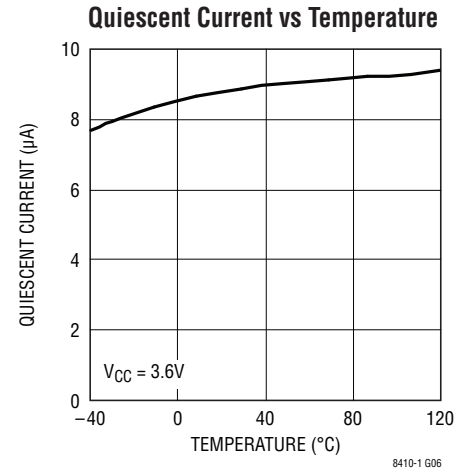
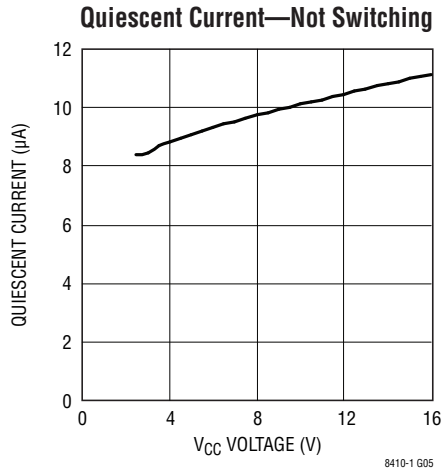
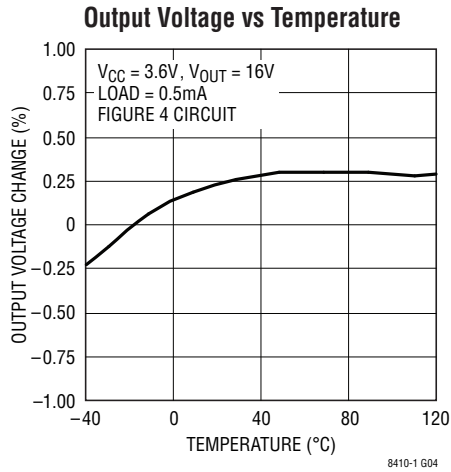

TYPICAL PERFORMANCE CHARACTERISTICS

LT8410 Switching Waveform at No Load

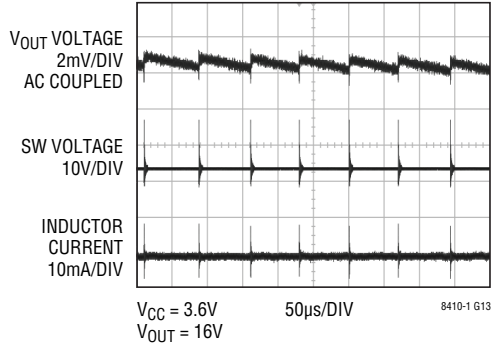

LT8410 Switching Waveform at 0.5mA Load

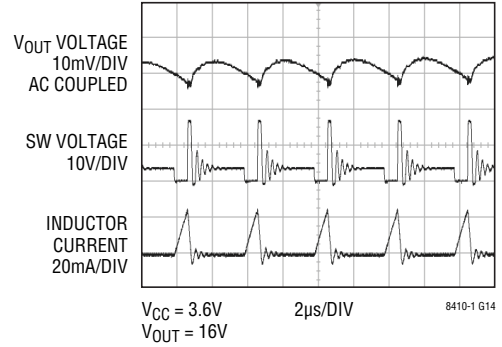

LT8410 Switching Waveform at 3mA Load

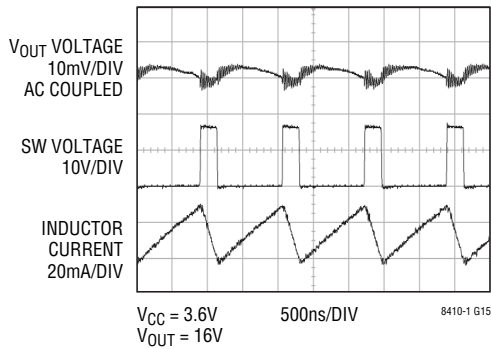

UVLO vs Temperature

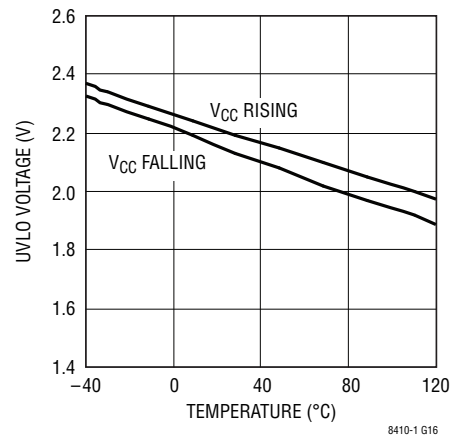

Line Regulation

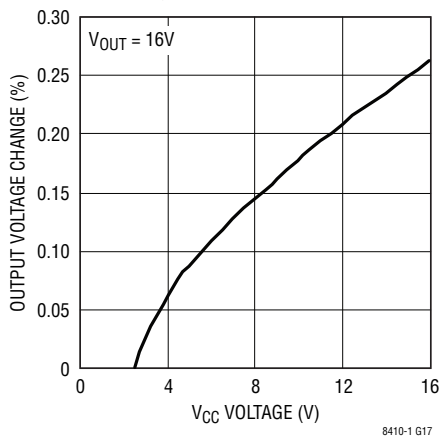

SHDN Minimum Input Voltage High vs Temperature

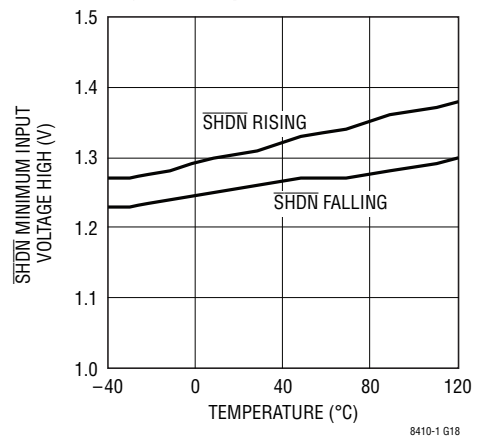

TYPICAL PERFORMANCE CHARACTERISTICS

Output Disconnect PMOS Current vs CAP to V_{OUT} Voltage Difference

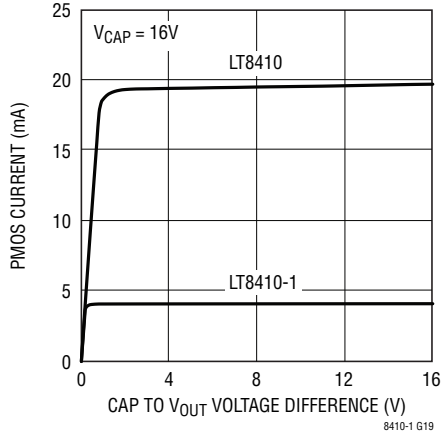

LT8410 Start-Up Waveforms without Capacitor at V_{REF} Pin

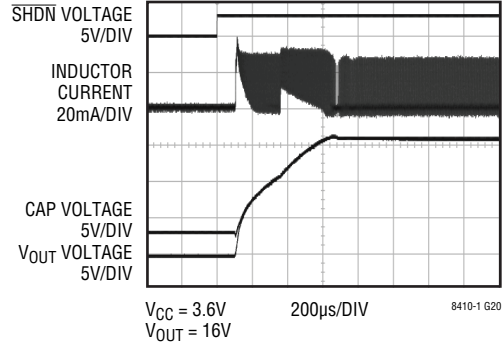

LT8410 Start-Up Waveforms with 0.1µF Capacitor at V_{REF} Pin

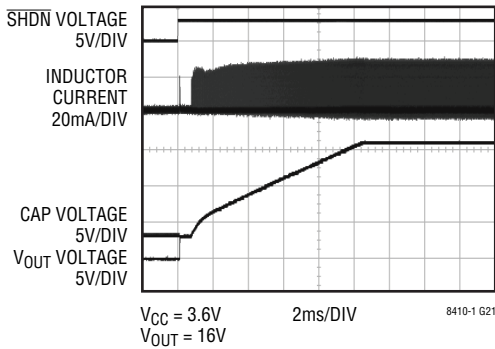

LT8410 Transient Response 0.5mA → 1.5mA → 0.5mA Load Pulse

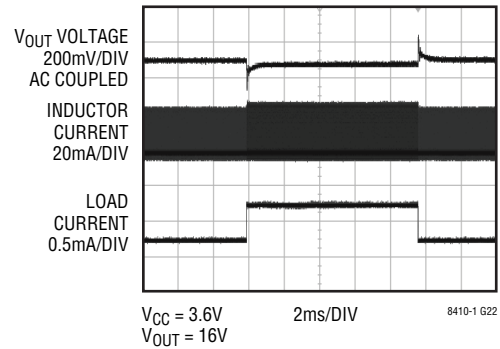

SW Saturation Voltage vs Switch Current (LT8410)

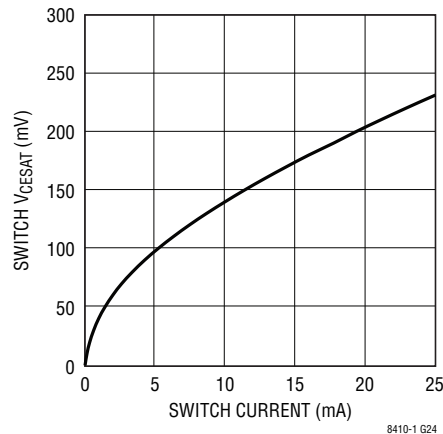

PIN FUNCTIONS

SHDN (Pin 1): Shutdown Pin. This pin is used to enable/disable the chip. Drive below 0.3V to disable the chip. Drive above 1.45V to activate the chip. Do not float this pin.

V_{CC} (Pin 2): Input Supply Pin. Must be locally bypassed to GND. See the Typical Applications section.

GND (Pin 3): Ground. Tie directly to local ground plane.

SW (Pin 4): Switch Pin. This is the collector of the internal NPN power switch. Minimize the metal trace area connected to this pin to minimize EMI.

V_{OUT} (Pin 5): Drain of Output Disconnect PMOS. Place a bypass capacitor from this pin to GND.

CAP (Pin 6): Cathode of the Internal Schottky Diode. Place a bypass capacitor from this pin to GND.

V_{REF} (Pin 7): Reference Pin. Soft-start can be achieved by placing a capacitor from this pin to GND. This cap will be discharged for 70μs (typical) at the beginning of start-up and then be charged to 1.235V with a 10μA current source.

FBP (Pin 8): Positive Feedback Pin. This pin is the error amplifier's positive input terminal. To achieve the desired output voltage, choose the FBP pin voltage (V_{FBP}) according to the following formula:

$$V_{FBP} = \frac{V_{OUT}}{31.85}$$

For protection purposes, the output voltage can not exceed 40V even if V_{FBP} is driven higher than V_{REF}.

Exposed Pad (Pin 9): Pin 9 is floating but must be grounded for proper shielding.

BLOCK DIAGRAM

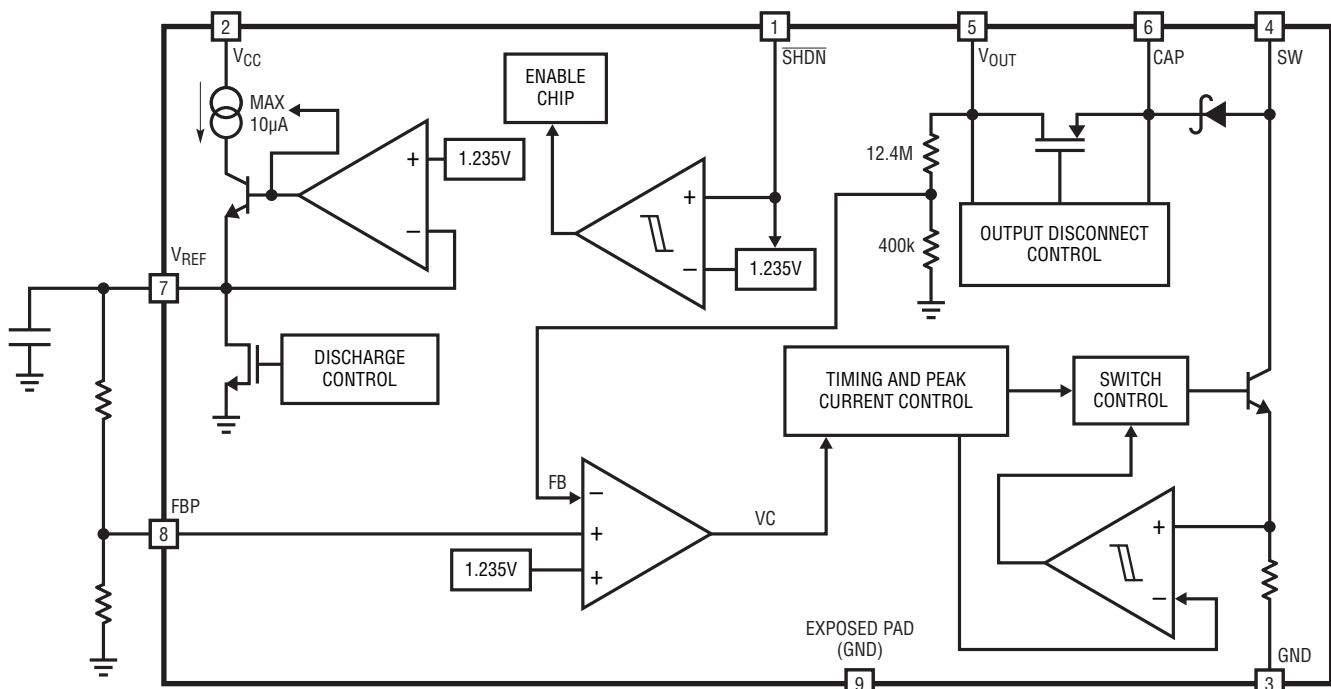

LT8410/LT8410-1

OPERATION

The LT8410 series utilizes a variable peak current, variable off-time control scheme to provide high efficiency over a wide output current range.

The operation of the part can be better understood by referring to the Block Diagram. The part senses the output voltage by monitoring the internal FB node, and servoing the FB node voltage to be equal to the FBP pin voltage. The chip integrates an accurate high value resistor divider (12.4M/0.4M) from the V_{OUT} pin. The output voltage is set by the FBP pin voltage, which in turn is set by an external resistor divider from the V_{REF} pin. The FBP pin voltage can also be directly biased with an external reference, allowing full control of the output voltage during operation.

The switch control block senses the output of the amplifier and adjusts the switching frequency as well as other parameters to achieve regulation. During the start-up of

the circuit, special precautions are taken to ensure that the inductor current remains under control

The LT8410 series also has a PMOS output disconnect switch. The PMOS switch is turned on when the part is enabled via the \overline{SHDN} pin. When the part is in shutdown, the PMOS switch turns off, allowing the V_{OUT} node to go to ground. This type of disconnect function is often required in power supplies.

The differences between the LT8410 and LT8410-1 are the SW current limit and the output disconnect PMOS current limit. For the LT8410, the SW current limit and PMOS current limit are approximately 25mA and 19mA, respectively, while those of the LT8410-1 are approximately 8mA and 4mA, respectively.

APPLICATIONS INFORMATION

Inductor Selection

Several inductors that work well with the LT8410 and LT8410-1 are listed in Table 1. The tables are not complete, and there are many other manufacturers and devices that can be used. Consult each manufacturer for more detailed information and for their entire selection of related parts, as many different sizes and shapes are available.

Inductors with a value of 47 μ H or higher are recommended for most LT8410 series designs. Inductors with low core losses and small DCR (copper wire resistance) are good choices for LT8410 series applications. For full output power, the inductor should have a saturation current rating higher than the peak inductor current. The peak inductor current can be calculated as:

$$I_{PK} = I_{LIMIT} + \frac{V_{IN} \cdot 150 \cdot 10^{-6}}{L} \text{ mA}$$

where the worst case I_{LIMIT} is 30mA and 10mA for LT8410 and LT8410-1, respectively. L is the inductance value in henrys and V_{IN} is the input voltage to the boost circuit.

Table 1. Recommended Inductors for LT8410/ LT8410-1

PART	L (μ H)	DCR (Ω)	SIZE (mm)	VENDOR
LQH2MCN680K02	68	6.6	2.0 × 1.6 × 0.9	Murata
LQH32CN101K53	100	3.5	3.2 × 2.5 × 2.0	www.murata.com
DO2010-683ML	68	8.8	2.0 × 2.0 × 1.0	Coilcraft
LPS3015-104ML	100	3.4	3.0 × 3.0 × 1.4	www.coilcraft.com
LPS3015-154ML	150	6.1	3.0 × 3.0 × 1.4	
LPS3314-154ML	150	4.1	3.3 × 3.3 × 1.3	

Capacitor Selection

The small size and low ESR of ceramic capacitors make them suitable for most LT8410 applications. X5R and X7R types are recommended because they retain their capacitance over wider voltage and temperature ranges than other types such as Y5V or Z5U. A 2.2 μ F or higher input capacitor, and a 0.1 μ F to 1 μ F output capacitor, are sufficient for most applications. Always use a capacitor with a sufficient voltage rating. Many ceramic capacitors rated at 0.1 μ F to 1 μ F have greatly reduced capacitance when bias voltages are applied. Be sure to check actual capacitance at the desired output voltage. Generally, a 0603

APPLICATIONS INFORMATION

or 0805 size capacitor will be adequate. A 0.1µF to 1µF capacitor placed on the CAP node is recommended to filter the inductor current, while a 0.1µF to 1µF capacitor placed on the V_{OUT} node will give excellent transient response and stability. To make the V_{REF} pin less sensitive to noise, putting a capacitor on the V_{REF} pin is recommended, but not required. A 47nF to 220nF 0402 capacitor will be sufficient. Table 2 shows a list of several capacitor manufacturers. Consult the manufacturers for more detailed information and for their entire selection of related parts.

Table 2. Recommended Ceramic Capacitor Manufacturers

MANUFACTURER	PHONE	WEB SITE
Taiyo Yuden	(408) 573-4150	www.t-yuden.com
Murata	(814) 237-1431	www.murata.com
AVX	(843) 448-9411	www.avxcorp.com
Kemet	(408) 986-0424	www.kemet.com
TDK	(847) 803-6100	www.tdk.com

Setting Output Voltage

The output voltage is set by the FBP pin voltage. V_{OUT} is equal to 31.85 • V_{FBP} when the output is regulated, as shown in Figure 1. Since the V_{REF} pin provides a good reference (1.235V), the FBP voltage can be easily set by a resistor divider from the V_{REF} pin to ground. The series resistance of this resistor divider should be kept larger than 200KΩ to prevent loading down the V_{REF} pin. The FBP pin can also be biased directly by an external reference. For overvoltage protection, the output voltage is limited to 40V. Therefore, if V_{FBP} is higher than 1.235V, the output voltage will stay at 40V.

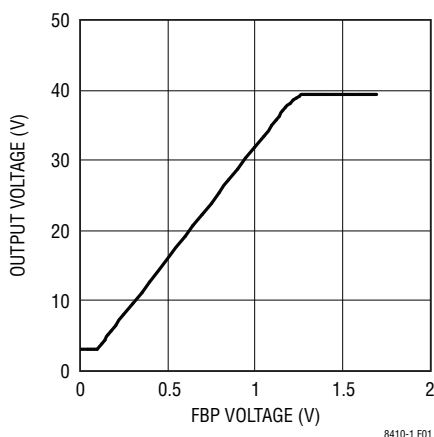

Figure 1. FBP to V_{OUT} Transfer Curve

Connecting the Load to the CAP Node

The efficiency of the converter can be improved by connecting the load to the CAP pin instead of the V_{OUT} pin.

The power loss in the PMOS disconnect circuit is then made negligible. No quiescent current will be consumed in the internal feedback resistor divider string during shutdown since the PMOS transistor will be open and the internal feedback resistor divider is connected at the V_{OUT} pin. The disadvantage of this method is that the CAP node cannot go to ground during shutdown, but will be limited to around a diode drop below V_{CC}. Loads connected to the part should only sink current. Never force external power supplies onto the CAP or V_{OUT} pins.

Maximum Output Load Current

The maximum output current of a particular LT8410 series circuit is a function of several circuit variables. The following method can be helpful in predicting the maximum load current for a given circuit:

Step 1. Calculate the peak inductor current:

$$I_{PK} = I_{LIMIT} + \frac{V_{IN} \cdot 150 \cdot 10^{-6}}{L} \text{ mA}$$

where I_{LIMIT} is 25mA and 8mA for LT8410 and LT8410-1 respectively. L is the inductance value in henrys and V_{IN} is the input voltage to the boost circuit.

Step 2. Calculate the inductor ripple current:

$$I_{RIPPLE} = \frac{(V_{OUT} + 1 - V_{IN}) \cdot 200 \cdot 10^{-6}}{L} \text{ mA}$$

where V_{OUT} is the desired output voltage. If the inductor ripple current is less than the peak current, then the circuit will only operate in discontinuous conduction mode. The inductor value should be increased so that I_{RIPPLE} < I_{PK}. An application circuit can be designed to operate only in discontinuous mode, but the output current capability will be reduced.

Step 3. Calculate the average input current:

$$I_{IN(AVG)} = I_{PK} - \frac{I_{RIPPLE}}{2} \text{ mA}$$

APPLICATIONS INFORMATION

Step 4. Calculate the nominal output current:

$$I_{OUT(NOM)} = \frac{I_{IN(AVG)} \cdot V_{IN} \cdot 0.7}{V_{OUT}} \text{mA}$$

Step 5. Derate output current:

$$I_{OUT} = I_{OUT(NOM)} \cdot 0.8$$

For low output voltages the output current capability will be increased. When using output disconnect (load current taken from V_{OUT}), these higher currents will cause the drop in the PMOS switch to be higher resulting in lower output current capability than predicted by the preceding equations.

Inrush Current

When V_{CC} is stepped from ground to the operating voltage while the output capacitor is discharged, a high level of inrush current may flow through the inductor and Schottky diode into the output capacitor. Conditions that increase inrush current include a larger more abrupt voltage step at V_{CC} , a larger output capacitor tied to the CAP pin and an inductor with a low saturation current. While the chip is designed to handle such events, the inrush current should not be allowed to exceed 0.3A. For circuits that use output capacitor values within the recommended range and have input voltages of less than 6V, inrush current remains low, posing no hazard to the device. In cases where there are large steps at V_{CC} (more than 6V) and/or a large capacitor is used at the CAP pin, inrush current should be measured to ensure safe operation.

Soft-Start

The LT8410 series contains a soft-start circuit to limit peak switch currents during start-up. High start-up current is inherent in switching regulators, in general, since the feedback loop is saturated due to V_{OUT} being far from its final value. The regulator tries to charge the output capacitor as quickly as possible, which results in large peak current.

When the FBP pin voltage is generated by a resistor divider from the V_{REF} pin, the start-up current can be limited by connecting an external capacitor (typically 47nF to 220nF) to the V_{REF} pin. When the part is brought out of shutdown, this capacitor is first discharged for about 70 μ s (providing

protection against pin glitches and slow ramping), then an internal 10 μ A current source pulls the V_{REF} pin slowly to 1.235V. Since the V_{OUT} voltage is set by the FBP pin voltage, the V_{OUT} voltage will also slowly increase to the regulated voltage, which results in lower peak inductor current. The voltage ramp rate on the pin can be set by the value of the V_{REF} pin capacitor.

Output Disconnect

The LT8410 series has an output disconnect PMOS that blocks the load from the input during shutdown. The maximum current through the PMOS is limited by circuitry inside the chip, helping the chip survive output shorts.

$\overline{\text{SHDN}}$ Pin Comparator and Hysteresis Current

An internal comparator compares the $\overline{\text{SHDN}}$ pin voltage with an internal voltage reference (1.3V) which gives a precise turn-on voltage level. The internal hysteresis of this turn-on voltage is about 60mV. When the chip is turned on, and the $\overline{\text{SHDN}}$ pin voltage is close to this turn-on voltage, 0.1 μ A current flows out of the $\overline{\text{SHDN}}$ pin. This current is called $\overline{\text{SHDN}}$ pin hysteresis current, and will go away when the chip is off. By connecting the external resistors as in Figure 2, a user-programmable enable voltage function can be realized.

The turn-on voltage for the configuration is:

$$1.30 \cdot \left(1 + \frac{R1}{R2} \right)$$

and the turn-off voltage is:

$$\left(1.24 - R3 \cdot 10^{-7} \right) \cdot \left(1 + \frac{R1}{R2} \right) - \left(R1 \cdot 10^{-7} \right)$$

where R1, R2 and R3 are resistance value in Ω .

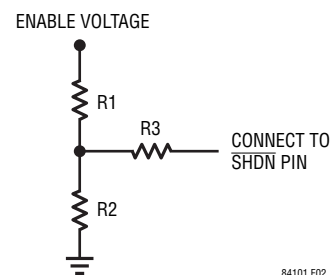

84101 F02

Figure 2. Programming Enable Voltage by Using External Resistors

84101fc

APPLICATIONS INFORMATION

Board Layout Considerations

As with all switching regulators, careful attention must be paid to the PCB layout and component placement. To maximize efficiency, switch rise and fall times are made as short as possible. To prevent electromagnetic interference (EMI) problems, proper layout of the high frequency switching path is essential. The voltage signal of the SW pin has sharp rising and falling edges. Minimize the length and area of all traces connected to the SW pin and always use a ground plane under the switching regulator to minimize interplane coupling. In addition, the FBP pin and V_{REF} pin are sensitive to noise. Minimize the length and area of all traces to these two pins is recommended. Recommended component placement is shown in Figure 3.

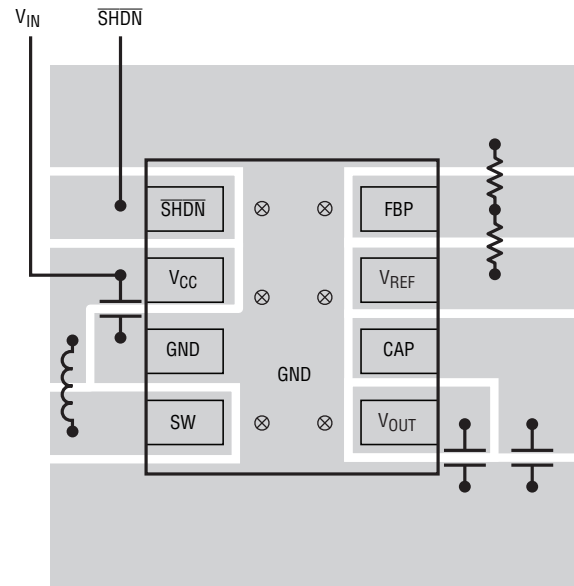

8410-1.F03

CAPACITOR GROUNDS MUST BE RETURNED DIRECTLY TO IC GROUND

Figure 3. Recommended Board Layout

LT8410/LT8410-1

TYPICAL APPLICATIONS

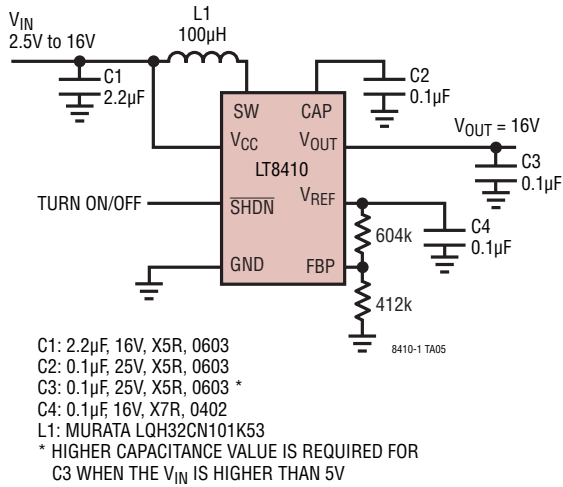
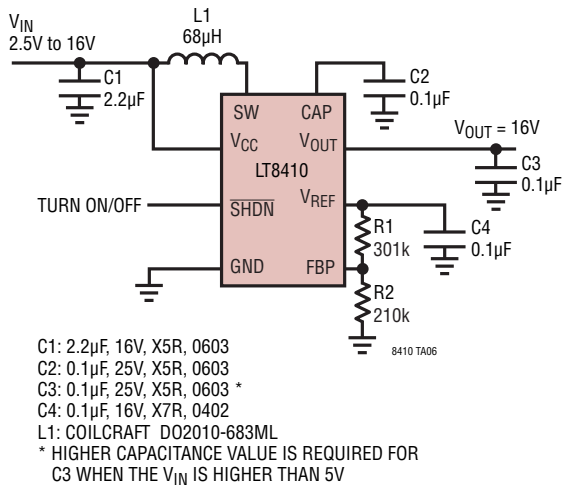
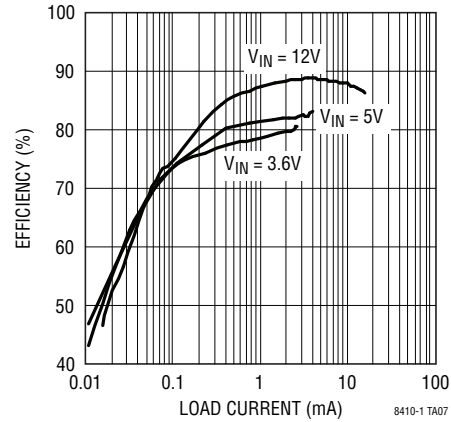

Figure 4. 16V Output Converter with Wide Input Voltage

16V Output Converter with 2mm × 2mm Inductor



Efficiency vs Load Current



V_{IN} (V)	I_{OUT} (mA)
3.6	2.2
5	3.6
12	13

Efficiency vs Load Current

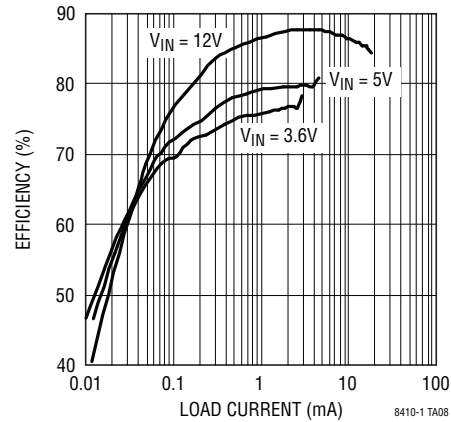

LT8410 Maximum Output Current vs Output Voltage

V_{OUT} (V)	RESISTOR DIVIDER FROM V_{REF} R1 (kΩ) / R2 (kΩ)	MAXIMUM OUTPUT CURRENT (mA)			
		$V_{IN} = 2.8V$	$V_{IN} = 3.6V$	$V_{IN} = 5V$	$V_{IN} = 12V$
40	NA	0.5	0.7	1.1	3.6
35	110/887	0.7	0.9	1.4	4.4
30	237/768	0.8	1	1.5	5.5
25	365/634	1	1.4	2.1	7.2
20	487/511	1.4	1.9	2.9	9.7
15	619/383	1.6	2.4	4	14
10	750/255	3.3	4.6	7	NA
5	866/127	8	11	17	NA

TYPICAL APPLICATIONS

34V Output Converter with Wide Input Voltage

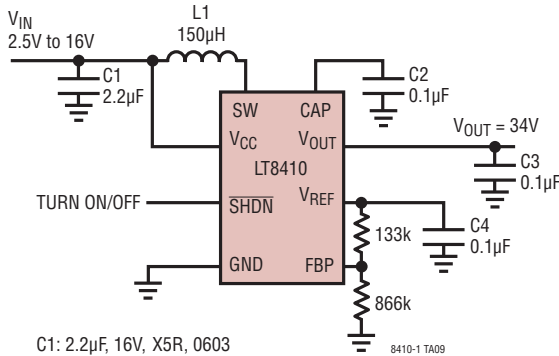

- C1: 2.2µF, 16V, X5R, 0603
- C2: 0.1µF, 100V, X5R, 0603
- C3: 0.1µF, 100V, X5R, 0603 *
- C4: 0.1µF, 16V, X7R, 0402
- L1: COILCRAFT LPS3314-154ML
- * HIGHER CAPACITANCE VALUE IS REQUIRED FOR C3 WHEN THE VIN IS HIGHER THAN 8V

Efficiency vs Load Current

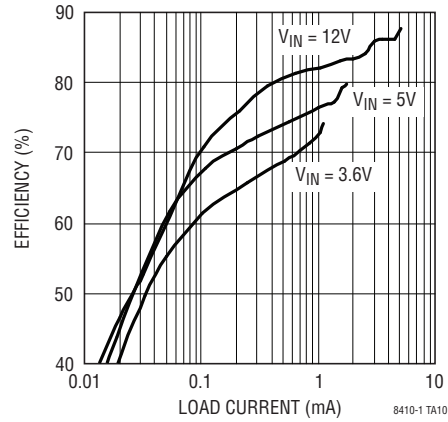

V _{IN} (V)	I _{OUT} (mA)
3.6	0.8
5	1.2
12	4

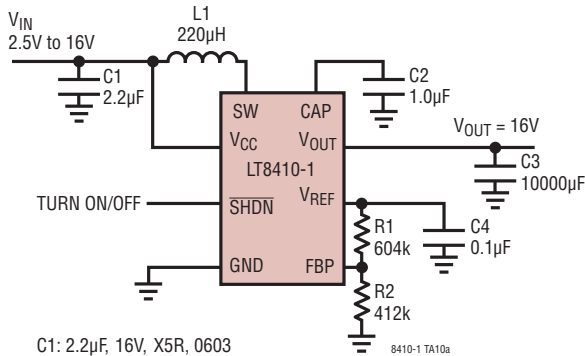

- C1: 2.2µF, 16V, X5R, 0603
- C2: 1.0µF, 25V, X5R, 0603 *
- C3: 10000µF, ELECTROLYTIC CAPACITOR
- C4: 0.1µF, 16V, X7R, 0402
- L1: COILCRAFT LPS3008-224ML
- * HIGHER CAPACITANCE VALUE IS REQUIRED FOR C2 WHEN THE VIN IS HIGHER THAN 12V

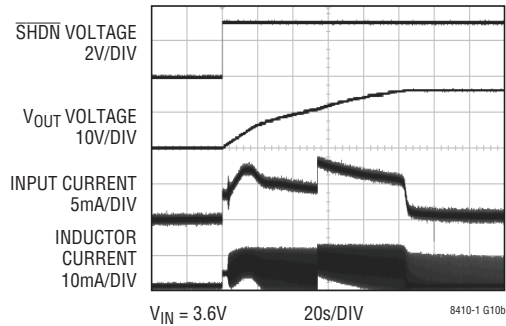

Figure 5. Capacitor Charger with the LT8410-1

LT8410-1 Maximum Output Current vs Output Voltage

V _{OUT} (V)	FEEDBACK RESISTOR DIVIDER R1 (kΩ) / R2 (kΩ)	MAXIMUM OUTPUT CURRENT (mA)			
		V _{IN} = 2.8V	V _{IN} = 3.6V	V _{IN} = 5V	V _{IN} = 12V
40	NA	0.12	0.16	0.24	0.89
35	110/887	0.14	0.19	0.3	1.1
30	237/768	0.18	0.25	0.38	1.5
25	365/634	0.25	0.35	0.55	2
20	487/511	0.34	0.48	0.76	2.9
15	619/383	0.48	0.69	1.1	3.5
10	750/255	0.84	1.2	2.1	NA
5	866/127	2.3	3.3	3.5	NA

PACKAGE DESCRIPTION

Please refer to <http://www.linear.com/product/LT8410#packaging> for the most recent package drawings.

DC8 Package 8-Lead Plastic DFN (2mm × 2mm) (Reference LTC DWG # 05-08-1719 Rev A)

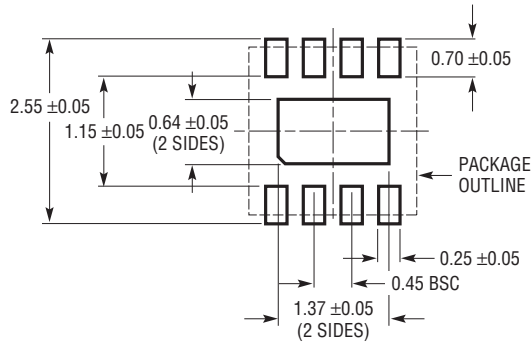

RECOMMENDED SOLDER PAD PITCH AND DIMENSIONS
APPLY SOLDER MASK TO AREAS THAT ARE NOT SOLDERED

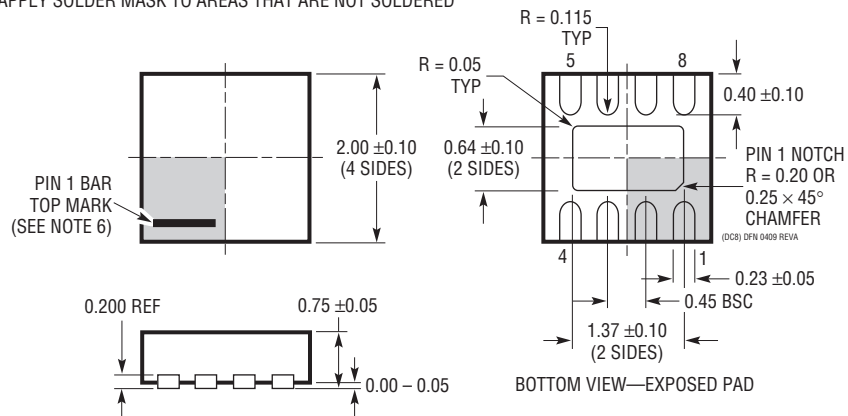

NOTE:

1. DRAWING IS NOT A JEDEC PACKAGE OUTLINE
2. DRAWING NOT TO SCALE
3. ALL DIMENSIONS ARE IN MILLIMETERS
4. DIMENSIONS OF EXPOSED PAD ON BOTTOM OF PACKAGE DO NOT INCLUDE MOLD FLASH. MOLD FLASH, IF PRESENT, SHALL NOT EXCEED 0.15mm ON ANY SIDE
5. EXPOSED PAD SHALL BE SOLDER PLATED
6. SHADED AREA IS ONLY A REFERENCE FOR PIN 1 LOCATION ON THE TOP AND BOTTOM OF PACKAGE

REVISION HISTORY (Revision history begins at Rev B)

REV	DATE	DESCRIPTION	PAGE NUMBER
B	01/11	Corrected Pin Configuration.	2
		Revised Note 2 in Electrical Characteristics.	3
C	04/16	Changed SW pin voltage Absolute Maximum to 42V.	2

TYPICAL APPLICATION

High Voltage Power Supply Does Not Need a Transformer

DANGER HIGH VOLTAGE! OPERATION BY HIGH VOLTAGE TRAINED PERSONNEL ONLY

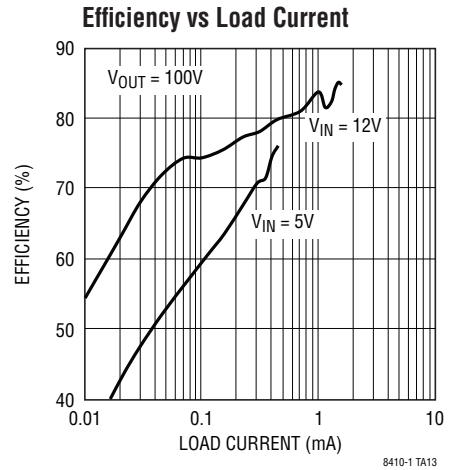
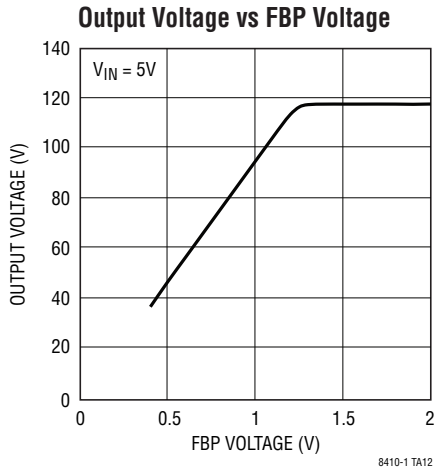
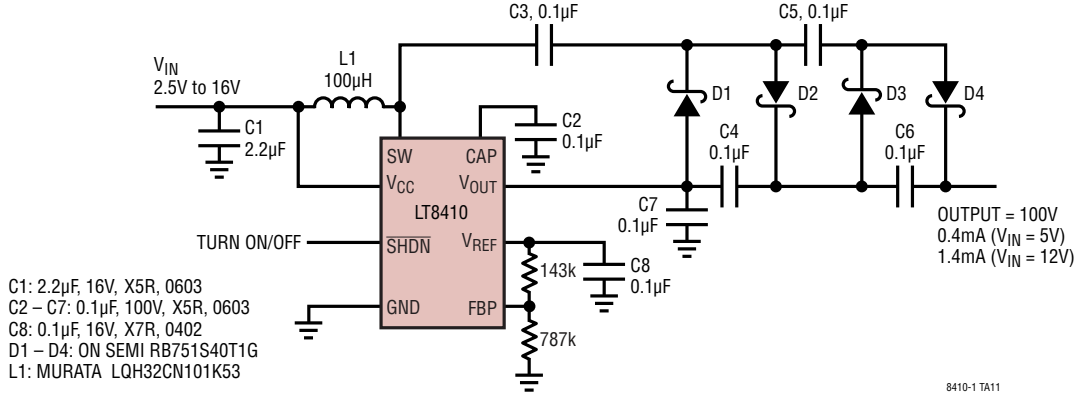

RELATED PARTS

PART NUMBER	DESCRIPTION	COMMENTS
LT1946/LT1946A	1.5A (I_{SW}), 1.2MHz/2.7MHz, High Efficiency Step-Up DC/DC Converters	V_{IN} : 2.45V to 16V, $V_{OUT(MAX)}$ = 34V, I_Q = 3.2mA, I_{SD} < 1µA, 8-Lead MS Package
LT3464	85mA (I_{SW}), High Efficiency Step-Up DC/DC Converter with Integrated Schottky and PNP Disconnect	V_{IN} : 2.3V to 10V, $V_{OUT(MAX)}$ = 34V, I_Q = 25µA, I_{SD} < 1µA, ThinSOT™ Package
LT3471	Dual Output, Boost/Inverter, 1.3A (I_{SW}), High Efficiency Boost-Inverting DC/DC Converter	V_{IN} : 2.4V to 16V, $V_{OUT(MAX)}$ = ±40V, I_Q = 2.5mA, I_{SD} < 1µA, DFN Package
LT3473/LT3473A	1A (I_{SW}), 1.2MHz, High Efficiency Step-Up DC/DC Converter with Integrated Schottky Diode and Output Disconnect	V_{IN} : 2.2V to 16V, $V_{OUT(MAX)}$ = 36V, I_Q = 100µA, I_{SD} < 1µA, DFN Package
LT3494/LT3494A	180mA/350mA (I_{SW}), High Efficiency, Low Noise Step-Up DC/DC Converter with Output Disconnect	V_{IN} : 2.1V to 16V, $V_{OUT(MAX)}$ = 40V, I_Q = 65µA, I_{SD} < 1µA, DFN Package
LT3495/LT3495B/ LT3495-1/LT3495B-1	650mA/350mA (I_{SW}), High Efficiency, Low Noise Step-Up DC/DC Converter with Output Disconnect	V_{IN} : 2.3V to 16V, $V_{OUT(MAX)}$ = 40V, I_Q = 60µA, I_{SD} < 1µA, DFN Package

Looking for pricing, stock, or lifecycle information?

Click below to explore more details on WIN SOURCE:

 [View LT8410EDC#TRPBF on WIN SOURCE](#)

 [Linear Technology](#) Information

Optimize Your Supply Chain with WIN SOURCE Solutions

-  Global Sourcing Solution
-  Obsolete Management
-  Cost Control Management
-  Shortage Management
-  Alternative Solution
-  Excess Inventory Management