



**THE DATASHEET OF  
LTC1044CN8**



# Switched Capacitor Voltage Converter

## FEATURES

- Plug-In Compatible with 7660 with These Additional Features:
  - Guaranteed Operation to 9V, with No External Diode, Over Full Temperature Range
  - Boost Pin (Pin 1) for Higher Switching Frequency
  - Lower Quiescent Power
  - Efficient Voltage Doubler
- 200µA Max. No Load Supply Current at 5V
- 97% Min. Open Circuit Voltage Conversion Efficiency
- 95% Min. Power Conversion Efficiency
- Wide Operating Supply Voltage Range, 1.5V to 9V
- East to Use
- Commercial Device Guaranteed Over -40°C to 85°C Temperature Range

## APPLICATIONS

- Conversion of 5V to ±5V Supplies
- Precise Voltage Division,  $V_{OUT} = V_{IN}/2 \pm 20\text{ppm}$
- Voltage Multiplication,  $V_{OUT} = \pm nV_{IN}$
- Supply Splitter,  $V_{OUT} = \pm V_S/2$

## DESCRIPTION

The **LTC®1044** is a monolithic CMOS switched capacitor voltage converter which is manufactured using Analog Devices' enhanced LTCMOS™ silicon gate process. The LTC1044 provides several voltage conversion functions: the input voltage can be inverted ( $V_{OUT} = -V_{IN}$ ), doubled ( $V_{OUT} = 2V_{IN}$ ), divided ( $V_{OUT} = V_{IN}/2$ ) or multiplied ( $V_{OUT} = \pm nV_{IN}$ ).

Designed to be pin-for-pin and functionally compatible with the popular 7660, the LTC1044 provides significant features and improvements over earlier 7660 designs. These improvements include: full 1.5V to 9V supply operation over the entire operating temperature range, without the need for external protection diodes; two and one-half times lower quiescent current for greater power conversion efficiency; and a “boost” function which is available to raise the internal oscillator frequency to optimize performance in specific applications.

Although the LTC1044 provides significant design and performance advantages over the earlier 7660 device, it still maintains its compatibility with existing 7660 designs.

All registered trademarks and trademarks are the property of their respective owners.

## TYPICAL APPLICATION

Generating CMOS Logic Supply from Two Mercury Batteries

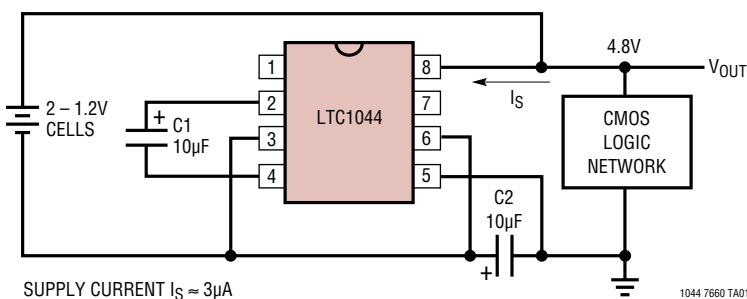

Supply Current vs Supply Voltage

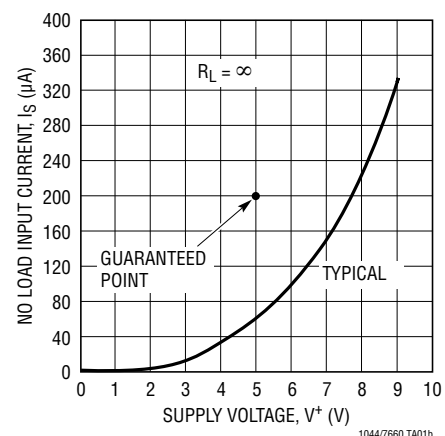

# LTC1044/7660

## ABSOLUTE MAXIMUM RATINGS

(Notes 1, 2)

Supply Voltage .....	9.5V
Input Voltage on Pins 1, 6 and 7 (Note 2) .....	$-0.3V \leq V_{IN} \leq V^+ + 0.3V$
Current into Pin 6 .....	20 $\mu$ A
Output Short Circuit Duration ( $V^+ \leq 5.5V$ ) .....	Continuous

Operating Temperature Range

LTC1044C .....  $-40^{\circ}\text{C} \leq T_A \leq 85^{\circ}\text{C}$

LTC1044M .....  $-55^{\circ}\text{C} \leq T_A \leq 125^{\circ}\text{C}$

Storage Temperature Range .....  $-65^{\circ}\text{C}$  to  $150^{\circ}\text{C}$

Lead Temperature (Soldering, 10sec).....  $300^{\circ}\text{C}$

## PIN CONFIGURATION

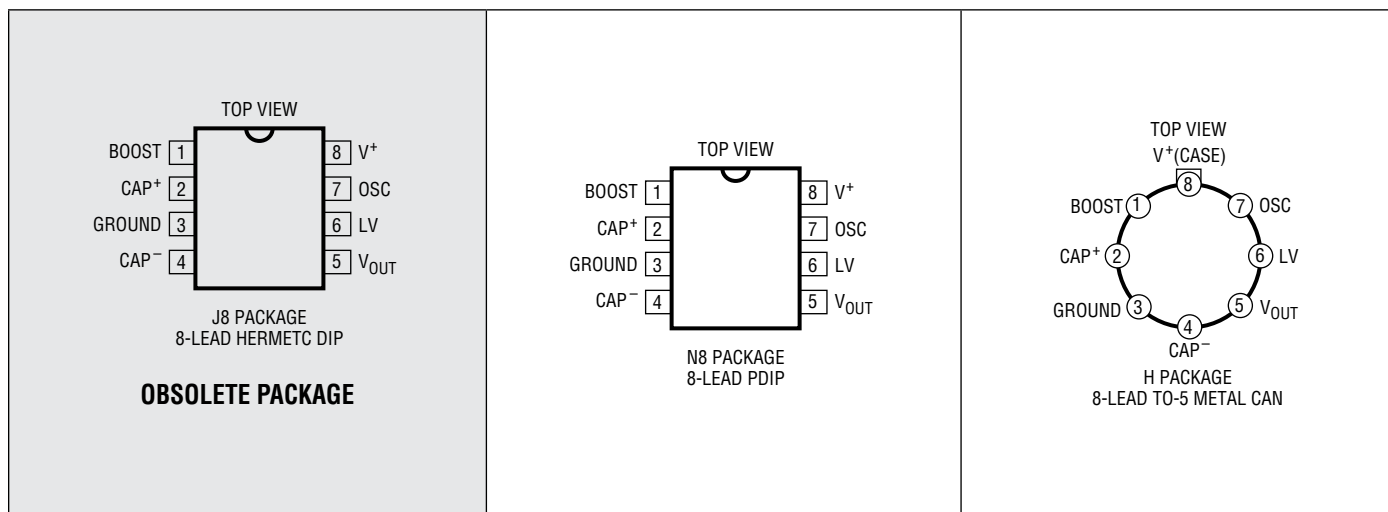

## ORDER INFORMATION

LEAD FREE FINISH	TAPE AND REEL	PART MARKING	PACKAGE DESCRIPTION	TEMPERATURE RANGE
LTC1044CH#PBF	LTC1044CH#TRPBF		Metal Can H Package	$-40^{\circ}\text{C}$ to $85^{\circ}\text{C}$
LTC1044MH#PBF	LTC1044MH#TRPBF		Metal Can H Package	$-55^{\circ}\text{C}$ to $125^{\circ}\text{C}$
OBSOLETE PACKAGE				
LTC1044CJ8#PBF	LTC1044CJ8#TRPBF		8-Lead CERDIP	$-40^{\circ}\text{C}$ to $85^{\circ}\text{C}$
LTC1044MJ8#PBF	LTC1044MJ8#TRPBF		8-Lead CERDIP	$-55^{\circ}\text{C}$ to $125^{\circ}\text{C}$
LTC1044CN8#PBF	LTC1044CN8#TRPBF		8-Lead PDIP	$0^{\circ}\text{C}$ to $70^{\circ}\text{C}$

Contact the factory for parts specified with wider operating temperature ranges.

[Tape and reel specifications.](#) Some packages are available in 500 unit reels through designated sales channels with #TRMPBF suffix.

## ELECTRICAL CHARACTERISTICS

The ● denotes the specifications which apply over the full operating temperature range, otherwise specifications are at  $T_A = 25^\circ\text{C}$ ,  $V^+ = 5\text{V}$ . Test circuit Figure 1, unless otherwise specified.

SYMBOL	PARAMETER	CONDITIONS	LTC1044M			LTC1044C			UNITS
			MIN	TYP	MAX	MIN	TYP	MAX	
$I_S$	Supply Current	$R_L = \infty$ , Pins 1 and 7 No Connection $R_L = \infty$ , Pins 1 and 7 $V^+ = 3\text{V}$		60 20	200		60 20	200	$\mu\text{A}$ $\mu\text{A}$
$V_L^+$	Minimum Supply Voltage	$R_L = 10\text{k}$	●	1.5			1.5		V
$V_H^+$	Maximum Supply Voltage	$R_L = 10\text{k}$ (Note 3)	●		9		9		V
$R_{OUT}$	Output Resistance	$I_L = 20\text{mA}$ , $f_{OSC} = 5\text{kHz}$ $V^+ = 2\text{V}$ , $I_L = 3\text{mA}$ , $f_{OSC} = 1\text{kHz}$	● ● ●		100 150 400		100 130 325		$\Omega$ $\Omega$ $\Omega$
$f_{OSC}$	Oscillator Frequency	$C_{OSC} = 1\text{pF}$ (Note 4) $V^+ = 5\text{V}$ $V^+ = 2\text{V}$	● ●	5 1		5 1			kHz kHz
$P_{EFF}$	Power Efficiency	$R_L = 5\text{k}\Omega$ , $f_{OSC} = 5\text{kHz}$		95	98		95	98	%
$V_{OUTEFF}$	Voltage Conversion Efficiency	$R_L = \infty$		97	99.9		97	99.9	%
$I_{OSC}$	Oscillator Sink or Source Current	$V_{OSC} = 0\text{V}$ or $V^+$ Pin 1 = $0\text{V}$ Pin 1 = $V^+$	● ●		3 20		3 20		$\mu\text{A}$ $\mu\text{A}$

**Note 1:** Stresses beyond those listed under Absolute Maximum Ratings may cause permanent damage to the device. Exposure to any Absolute Maximum Rating condition for extended periods may affect device reliability and lifetime.

**Note 2:** Connecting any input terminal to voltages greater than  $V^+$  or less than ground may cause destructive latch-up. It is recommended that no inputs from sources operating from external supplies be applied prior to power-up of the LTC1044.

**Note 3:** The LTC1044 is guaranteed to operate with alkaline, mercury or NiCad 9V batteries, even though the initial battery voltage may be slightly higher than 9V.

**Note 4:**  $f_{OSC}$  is tested with  $C_{OSC} = 100\text{pF}$  to minimize the effects of test fixture capacitance loading. The 1pF frequency is correlated to this 100pF test point, and is intended to simulate the capacitance at pin 7 when the device is plugged into a test socket and no external capacitor is used.

## TYPICAL PERFORMANCE CHARACTERISTICS (Using Test Circuit Shown in Figure 1)

**Operating Voltage Range vs Temperature**

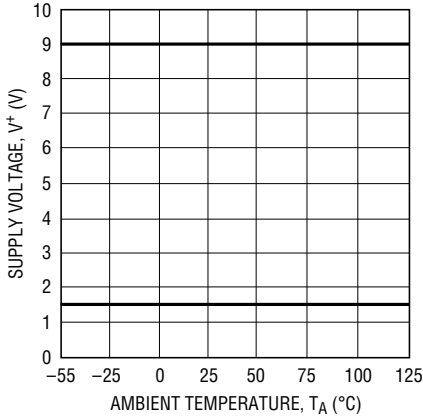

**Power Efficiency vs Oscillator Frequency**

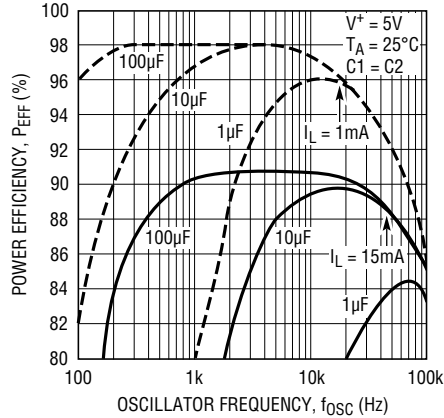

**Output Resistance vs Oscillator Frequency**

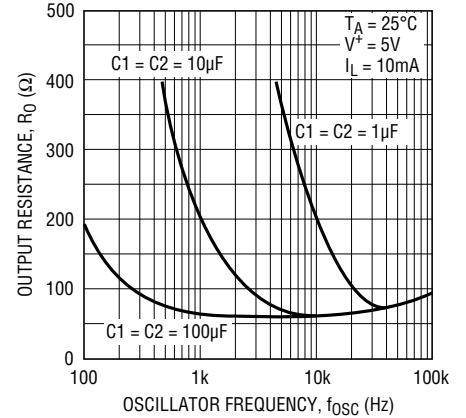

**Power Conversion Efficiency vs Load Current for V+ = 2V**

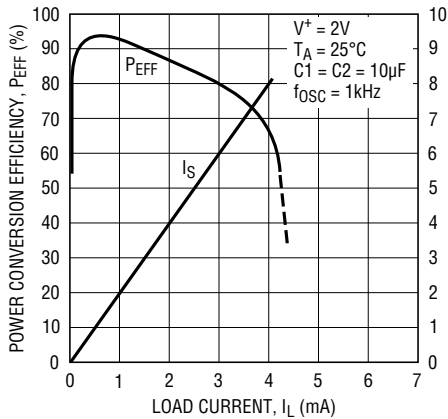

**Power Conversion Efficiency vs Load Current for V+ = 5V**

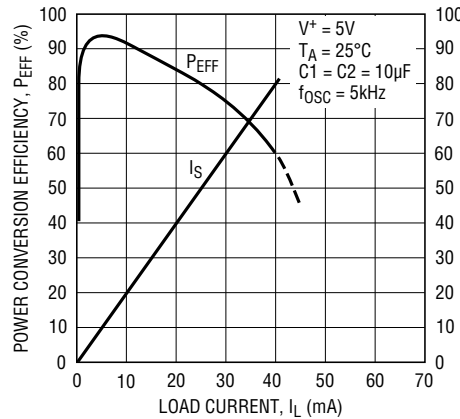

**Output Resistance vs Supply Voltage**

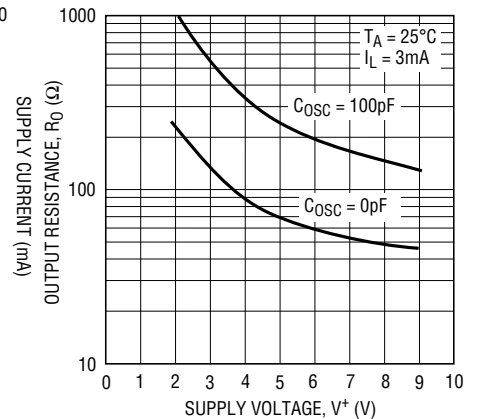

**Output Voltage vs Load Current for V+ = 2V**

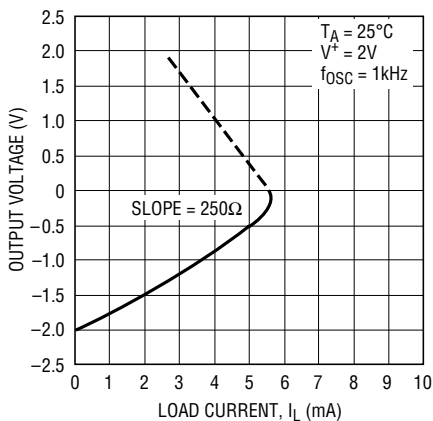

**Output Voltage vs Load Current for V+ = 5V**

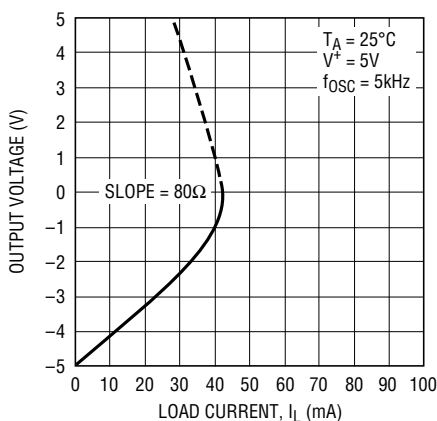

**Output Resistance vs Temperature**

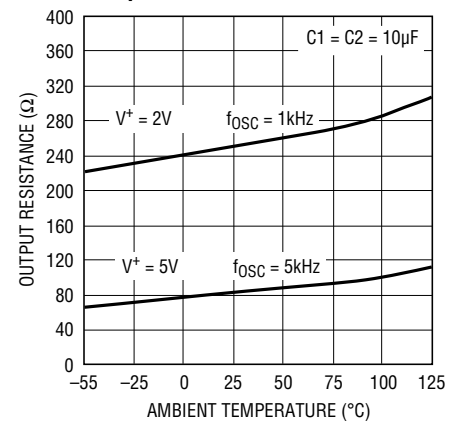

## TYPICAL PERFORMANCE CHARACTERISTICS

(Using Test Circuit Shown in Figure 1)

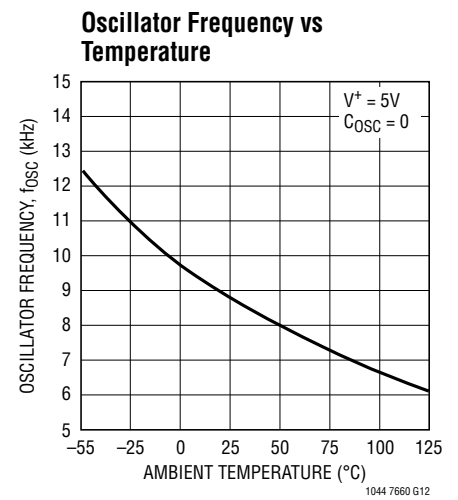
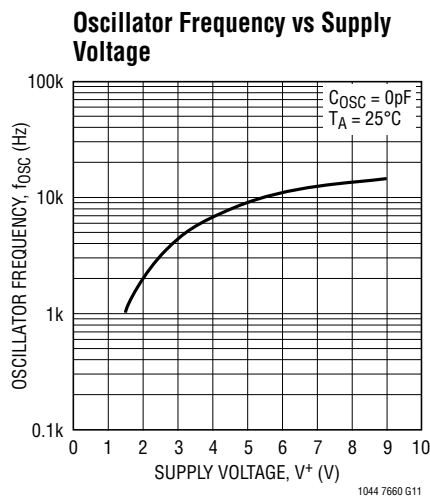
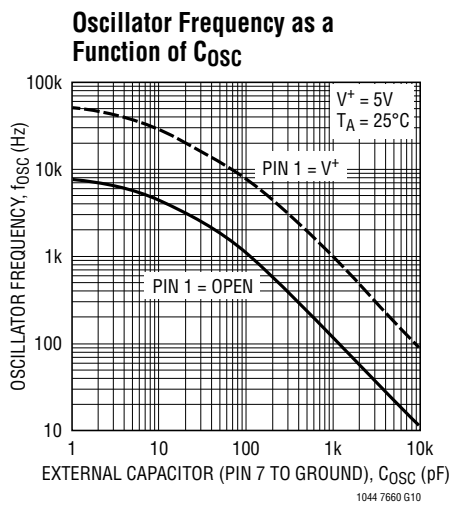

## TEST CIRCUIT

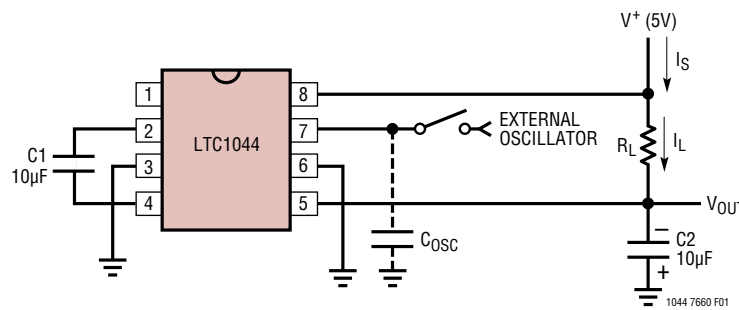

Figure 1

## APPLICATIONS INFORMATION

### Theory of Operation

To understand the theory of operation of the LTC1044, a review of a basic switched capacitor building block is helpful.

In Figure 2, when the switch is in the left position, capacitor  $C1$  will charge to voltage  $V1$ . The total charge on  $C1$  will be  $q1 = C1V1$ . The switch then moves to the right, discharging  $C1$  to voltage  $V2$ . After this discharge time, the charge on  $C1$  is  $q2 = C1V2$ . Note that charge has been transferred from the source,  $V1$ , to the output,  $V2$ . The amount of charge transferred is:

$$\Delta q = q1 - q2 = C1(V1 - V2).$$

If the switch is cycled  $f$  times per second, the charge transfer per unit time (i.e., current) is:

$$I = f \times \Delta q = f \times C1(V1 - V2).$$

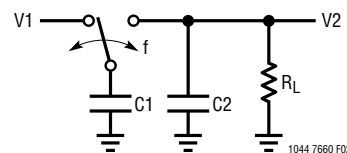

Figure 2. Switched Capacitor Building Block

## APPLICATIONS INFORMATION

Rewriting in terms of voltage and impedance equivalence,

$$I = \frac{V1 - V2}{\left(\frac{1}{fC1}\right)} = \frac{V1 - V2}{R_{EQUIV}}$$

A new variable,  $R_{EQUIV}$ , has been defined such that  $R_{EQUIV} = 1/fC1$ . Thus, the equivalent circuit for the switched capacitor network is as shown in Figure 3.

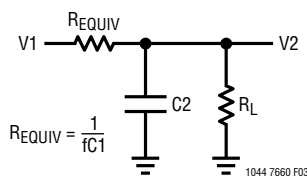

Figure 3. Switched Capacitor Equivalent Circuit

Examination of Figure 4 shows that the LTC1044 has the same switching action as the basic switched capacitor building block. With the addition of finite switch on-resistance and output voltage ripple, the simple theory, although not exact, provides an intuitive feel for how the device works.

For example, if you examine power conversion efficiency as a function of frequency (see typical curve), this simple theory will explain how the LTC1044 behaves. The loss, and hence the efficiency, is set by the output impedance. As frequency is decreased, the output impedance will eventually be dominated by the  $1/fC1$  term and power efficiency will drop. The typical curves for power efficiency versus frequency show this effect for various capacitor values.

Note also that power efficiency decreases as frequency goes up. This is caused by internal switching losses which occur due to some finite charge being lost on each switching cycle. This charge loss per unit cycle, when multiplied by the switching frequency, becomes a current loss. At high frequency this loss becomes significant and the power efficiency starts to decrease.

### LV (Pin 6)

The internal logic of the LTC1044 runs between  $V^+$  and LV (pin 6). For  $V^+$  greater than or equal to 3V, an internal switch shorts LV to GND (pin 3). For  $V^+$  less than 3V, the LV pin should be tied to GND. For  $V^+$  greater than or equal to 3V, the LV pin can be tied to GND or left floating.

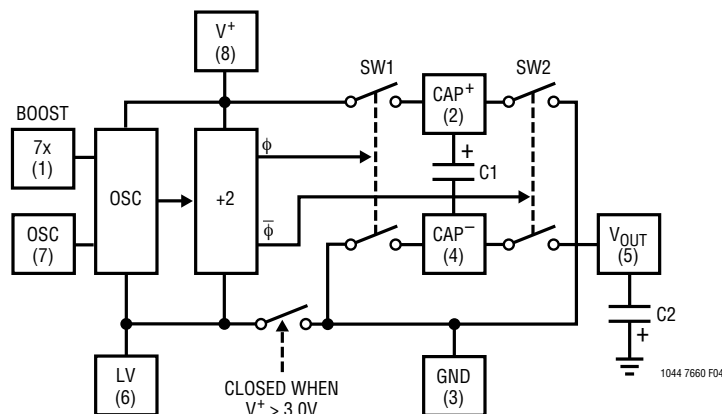

Figure 4. LTC1044 Switched Capacitor Voltage Converter Block Diagram

## APPLICATIONS INFORMATION

### OSC (Pin 7) and Boost (Pin 1)

The switching frequency can be raised, lowered or driven from an external source. Figure 5 shows a functional diagram of the oscillator circuit.

By connecting the boost pin (pin 1) to  $V^+$ , the charge and discharge current is increased and, hence, the frequency is increased by approximately seven times. Increasing the frequency will decrease output impedance and ripple for higher loads currents.

Loading pin 7 with more capacitance will lower the frequency. Using the boost (pin 1) in conjunction with external capacitance on pin 7 allows user selection of the frequency over a wide range.

Driving the LTC1044 from an external frequency source can be easily achieved by driving pin 7 and leaving the boost pin open, as shown in Figure 6. The output current from pin 7 is small, typically  $0.5\mu\text{A}$ , so a logic gate is capable of driving this current. The choice of using a CMOS logic gate is best because it can operate over a wide supply voltage range (3V to 15V) and has enough voltage swing to drive the internal Schmitt trigger shown in Figure 5. For 5V applications, a TTL logic gate can be used by simply adding an external pull-up resistor (see Figure 6).

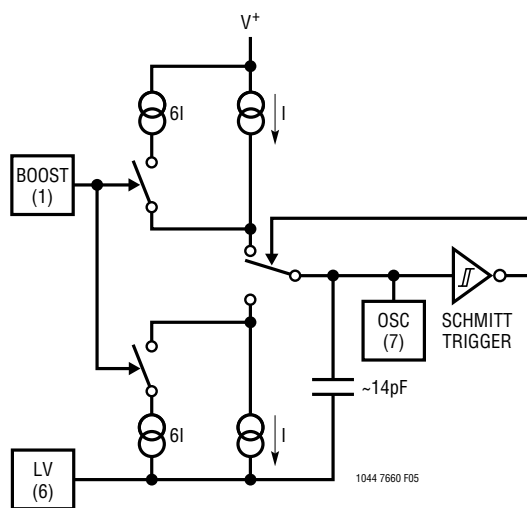

Figure 5. Oscillator

### External Diode (Dx)

Previous circuits of this type have required a diode between  $V_{\text{OUT}}$  (pin 5) and the external capacitor, C2, for voltages above 6.5V (5V for military temperature range). Because of improvements which have been made in the LTC1044 circuit design and Analog Devices' silicon gate CMOS process, this diode is no longer required. The LTC1044 will operate from 1.5V to 9V, without the protection diode, over all temperature ranges.

It should, however, be noted that the LTC1044 will operate without any problems in existing 7660 designs which use the protection diode, as long as the maximum operating voltage ( $V^+$ ) of 9V is not exceeded.

### Capacitor Selection

External capacitors C1 and C2 are not critical. Matching is not required, nor do they have to be high quality or tight tolerance. Aluminum or tantalum electrolytics are excellent choices, with cost and size being the only consideration.

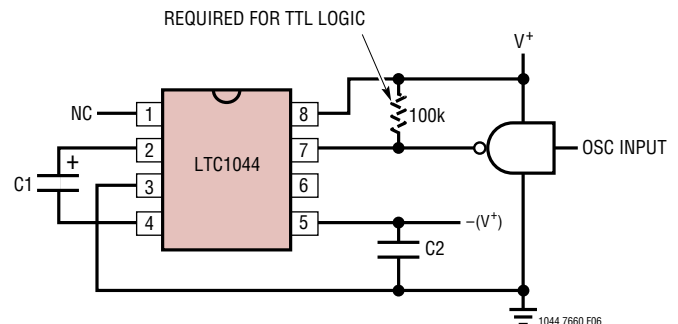

Figure 6. External Clocking

## TYPICAL APPLICATIONS

### Negative Voltage Converter

Figure 7 shows a typical connection which will provide a negative supply from an available positive supply. This circuit operates over full temperature and power supply ranges without the need of any external diodes. The LV pin (pin 6) is shown grounded, but for  $V^+ \geq 3V$  it may be “floated”, since LV is internally switched to ground (pin 3) for  $V^+ \geq 3V$ .

The output voltage (pin 5) characteristics of the circuit are those of a nearly ideal voltage source in series with an  $80\Omega$  resistor. The  $80\Omega$  output impedance is composed of two terms: 1) the equivalent switched capacitor resistance (see Theory of Operation) and 2) a term related to the on-resistance of the MOS switches.

At an oscillator frequency of 10kHz and  $C1 = 10\mu F$ , the first term is:

$$R_{EQUIV} = \frac{1}{(f_{OSC}/2) \cdot C1} = \frac{1}{5 \cdot 10^3 \cdot 10 \cdot 10^{-6}} = 20\Omega$$

Notice that the above equation for  $R_{EQUIV}$  is not a capacitive reaction equation ( $X_C = 1/\omega C$ ) and does not contain a  $2\pi$  term.

The exact expression for output impedance is extremely complex, but the dominant effect of the capacitor is clearly shown on the typical curves of output impedance and power efficiency versus frequency. For  $C1 = C2 = 10\mu F$ , the output impedance goes from  $60\Omega$  at  $f_{OSC} = 10kHz$  to  $200\Omega$  at  $f_{OSC} = 1kHz$ . As the  $1/fC$  term becomes large compared to the switch on-resistance term, the output resistance is determined by  $1/fC$  only.

### Voltage Doubling

Figure 8 shows two methods of voltage doubling. In Figure 8a doubling is achieved by simply rearranging the connection of the two external capacitors. When the input voltage is less than 3V, an external  $1M\Omega$  resistor is required to ensure the oscillator will start. It is not required for higher input voltages.

In this application the ground input (pin 3) is taken above  $V^+$  (pin 8) during turn-on, making it prone to latch-up. The latch-up is not destructive but simply prevents the circuit from doubling. Resistor R1 is added to eliminate the problem. In most cases  $200\Omega$  is sufficient. It may be necessary in a particular application to increase this value to guarantee start-up.

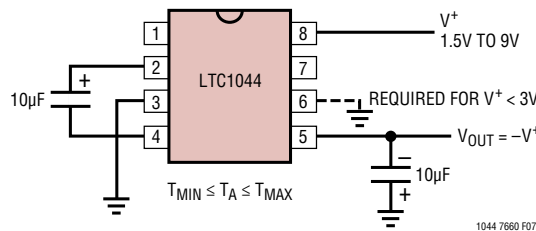

Figure 7. Negative Voltage Converter

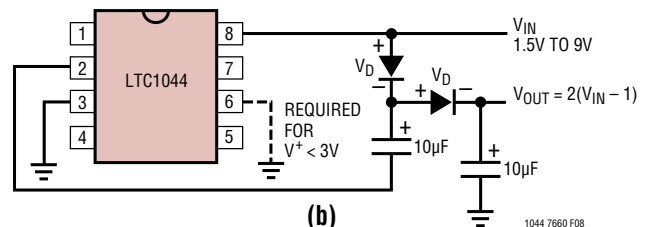
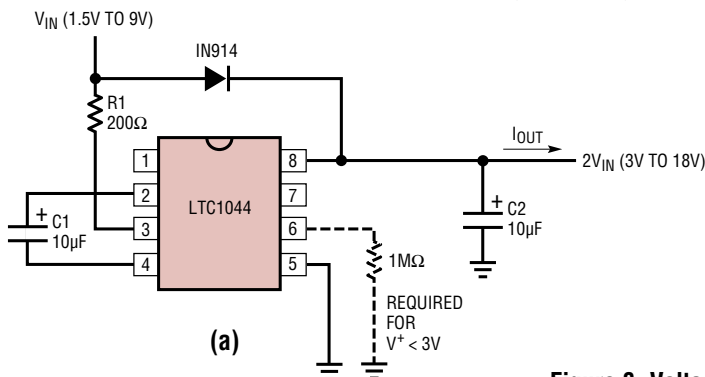

Figure 8. Voltage Doubler

## TYPICAL APPLICATIONS

The voltage drop across R1 is:  $V_{R1} = 2 \times I_{OUT} \times R1$ . If this voltage exceeds two diode drops (1.4V for silicon, 0.8V for Schottky), the circuit in Figure 8a is recommended. This circuit will never have a start-up problem.

### Ultra Precision Voltage Divider

An ultra precision voltage divider is shown in Figure 9. To achieve the 0.0002% accuracy indicated, the load current should be kept below 100nA. However, with a slight loss in accuracy, the load current can be increased.

### Battery Splitter

A common need in many systems is to obtain (+) and (-) supplies from a single battery or single power supply system. Where current requirements are small, the circuit shown in Figure 10 is a simple solution. It provides symmetrical  $\pm$  output voltages, both equal to one half the input voltage. The output voltages are both referenced to pin 3 (output common). If the input voltage between pin 8 and pin 5 is less than 6V, pin 6 should also be connected to pin 3, as shown by the dashed line.

### Paralleling for Lower Output Resistance

Additional flexibility of the LTC1044 is shown in Figures 11, 12 and 13.

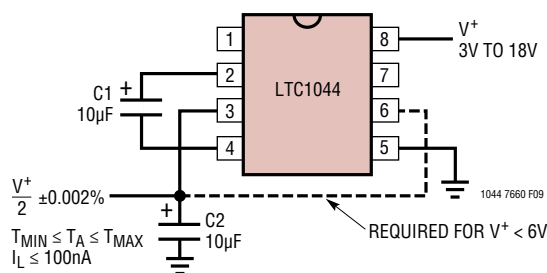

Figure 9. Ultra Precision Voltage Divider

Figure 11 shows two LTC1044s connected in parallel to provide a lower effective output resistance. If, however, the output resistance is dominated by  $1/fC1$ , increasing the capacitor size (C1) or increasing the frequency will be of more benefit than the paralleling circuit shown.

Figures 12 and 13 make use of “stacking” two LTC1044s to provide even higher voltages. In Figure 12, a negative voltage doubler or tripler can be achieved, depending upon how pin 8 of the second LTC1044 is connected, as shown schematically by the switch. Figure 13 indicates a similar circuit which can be used to obtain positive tripling, or even quadrupling (the doubler circuit appears in Figure 8a). In both of these circuits, the available output current will be dictated/decreased by the product of the individual power conversion efficiencies and the voltage step-up ratio.

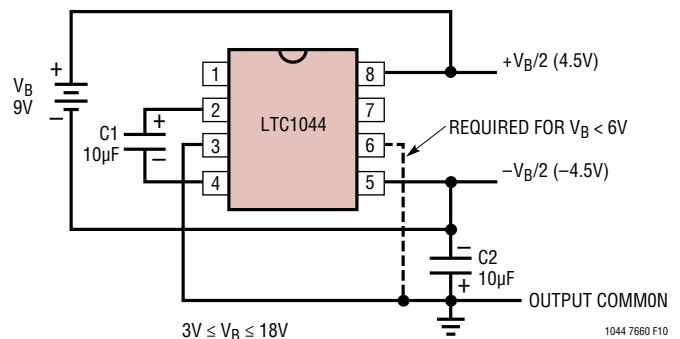
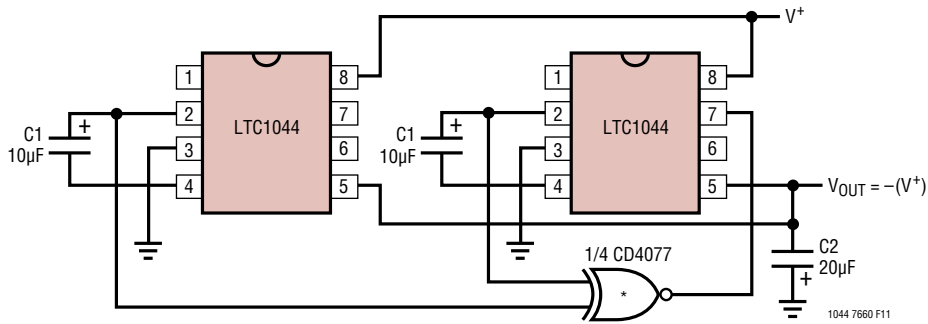

Figure 10. Battery Splitter

## TYPICAL APPLICATIONS



\*THE EXCLUSIVE NOR GATE SYNCHRONIZES BOTH LTC1044s TO MINIMIZE RIPPLE

**Figure 11. Paralleling for Lower Output Resistance**

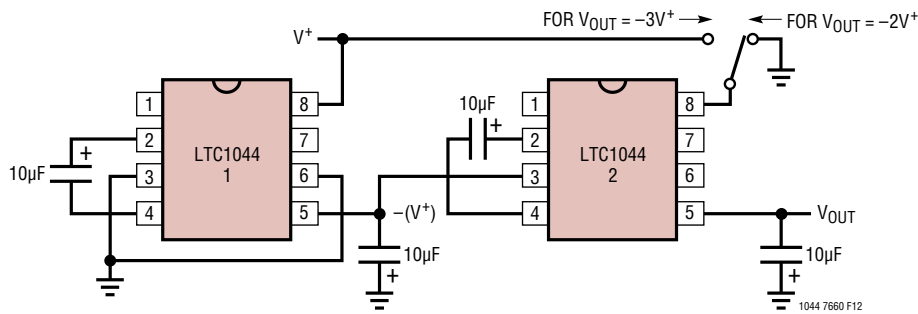

**Figure 12. Stacking for Higher Voltage**

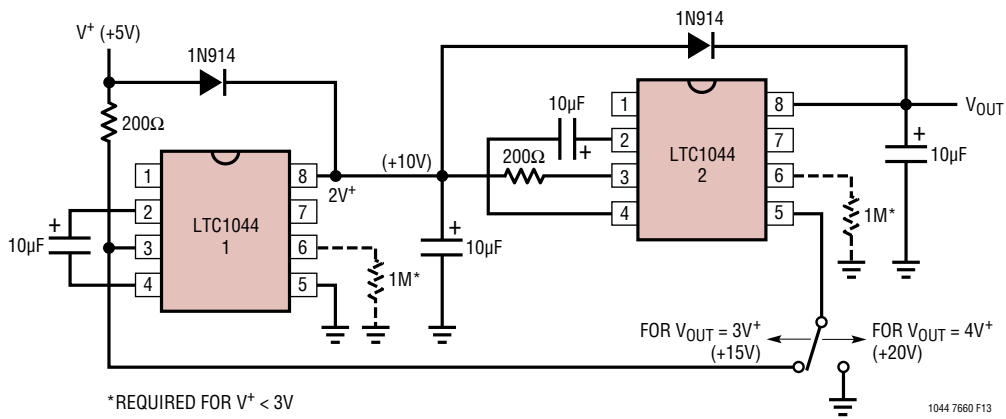

\*REQUIRED FOR  $V^+ < 3V$

**Figure 13. Voltage Tripler/Quadrupler**

TYPICAL APPLICATIONS

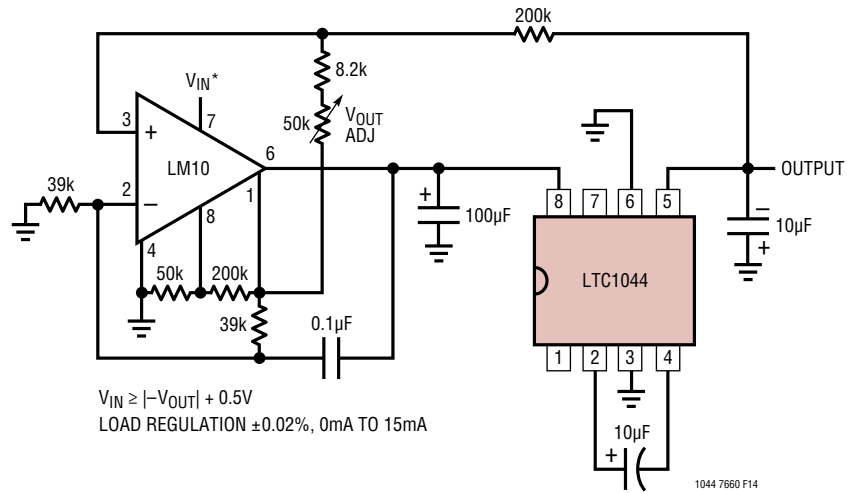

Figure 14. Low Output Impedance Voltage Converter

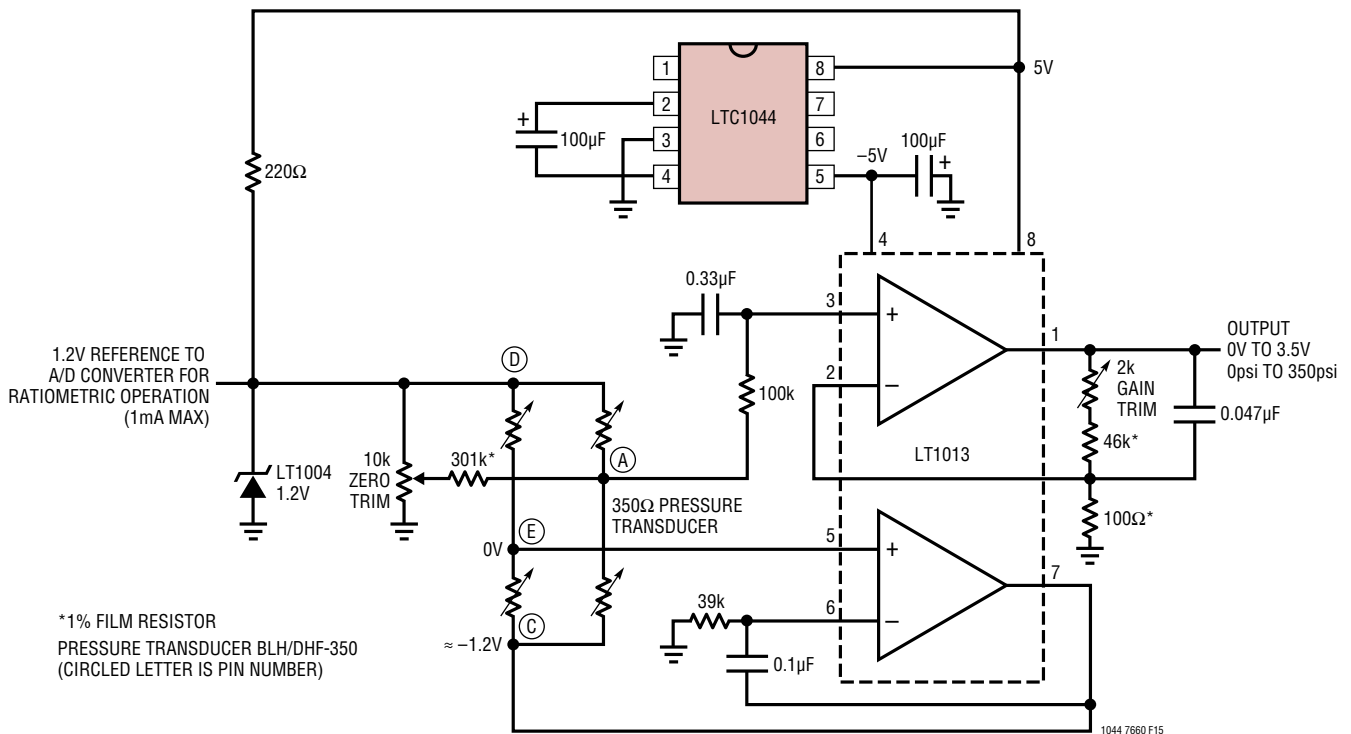

Figure 15. Single 5V Strain Gauge Bridge Signal Conditioner

## TYPICAL APPLICATIONS

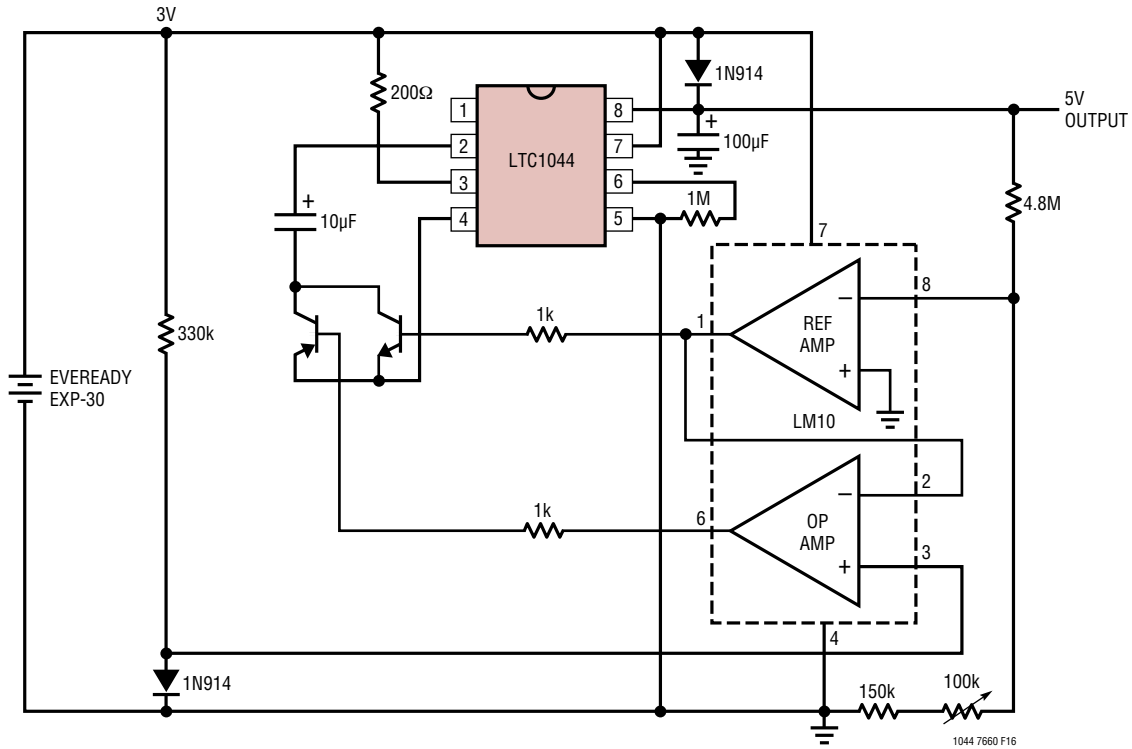

Figure 16. Regulated Output 3V to 5V Converter

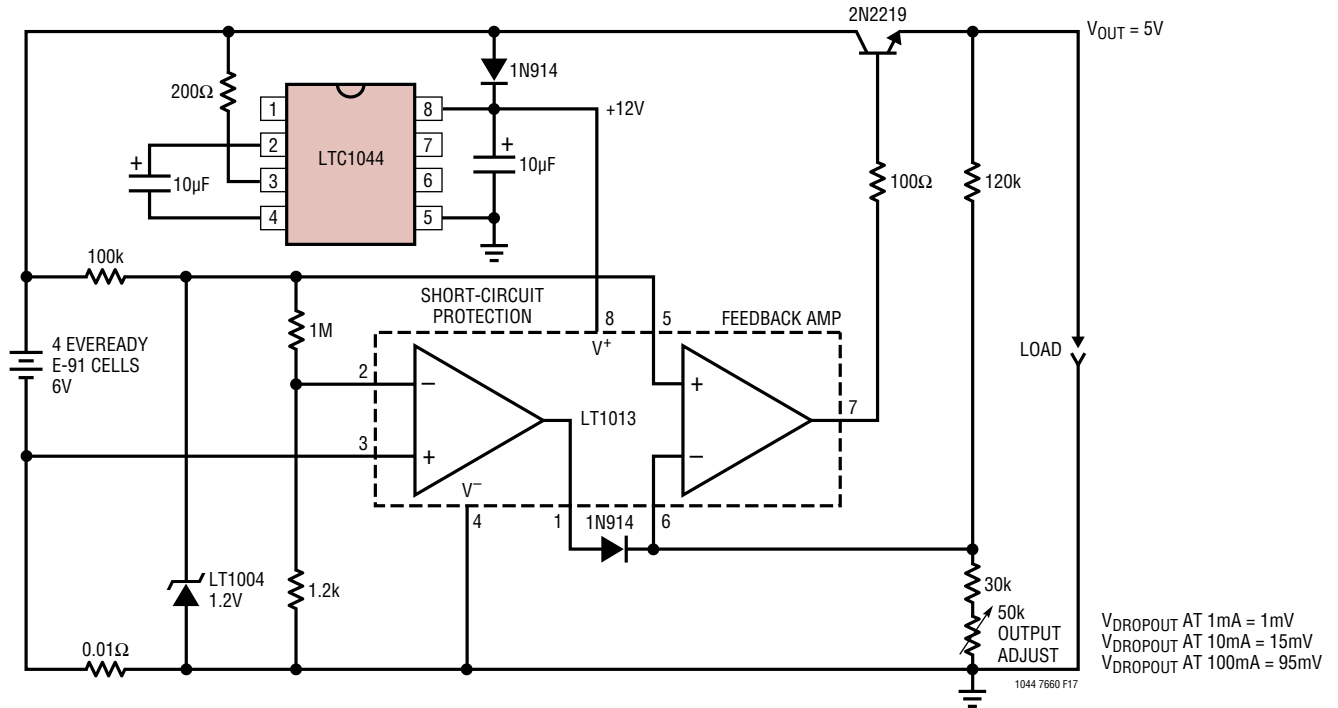
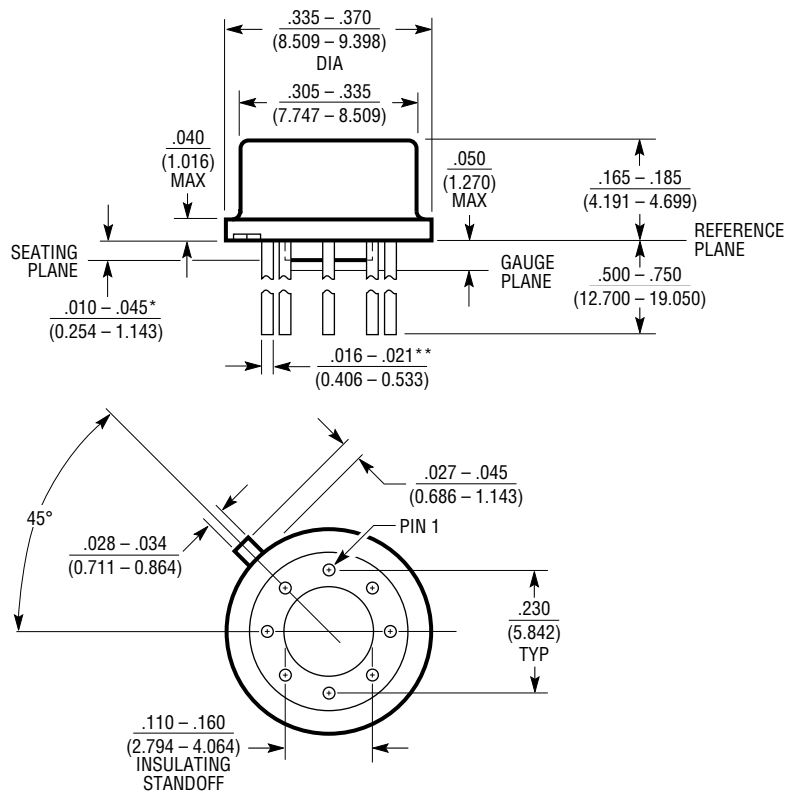

Figure 17. Low Dropout 5V Regulator

**PACKAGE DESCRIPTION**

**H Package**  
**8-Lead TO-5 Metal Can (.230 Inch PCD)**  
 (Reference LTC DWG # 05-08-1321)



\* LEAD DIAMETER IS UNCONTROLLED BETWEEN THE REFERENCE PLANE AND THE SEATING PLANE

\*\* FOR SOLDER DIP LEAD FINISH, LEAD DIAMETER IS  $.016 - .024$  (0.406 - 0.610) H8 (TO-5) 0.230 PCD 0204

**PACKAGE DESCRIPTION**

**J8 Package**  
**8-Lead CERDIP (Narrow .300 Inch, Hermetic)**  
 (Reference LTC DWG # 05-08-1110)

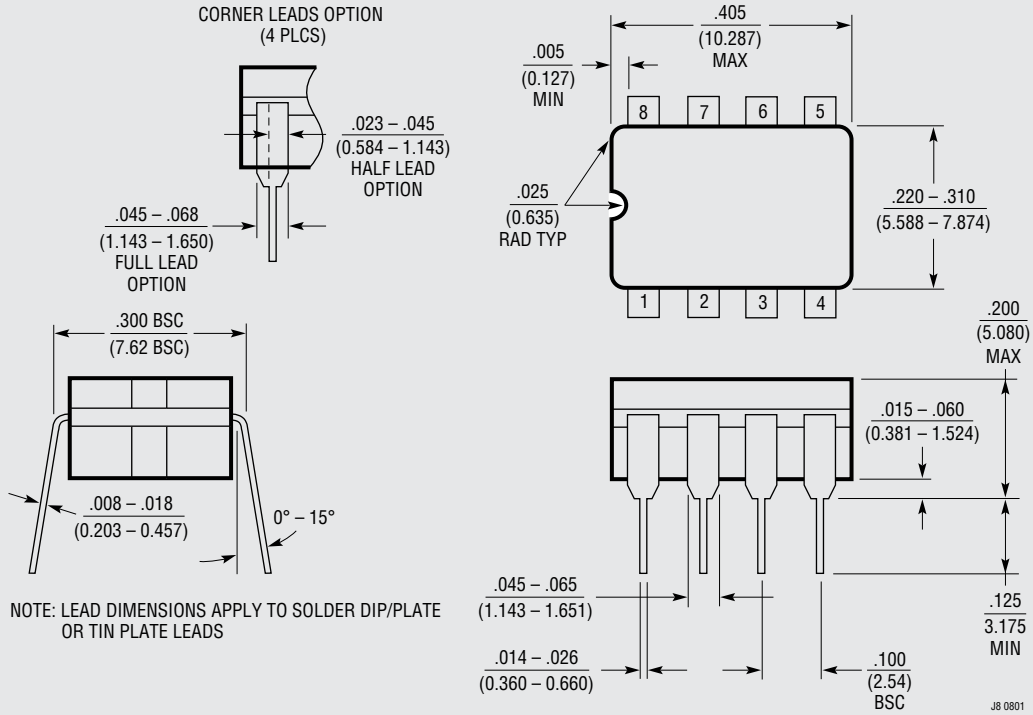

**OBSOLETE PACKAGE**

---

# REVISION HISTORY

REV	DATE	DESCRIPTION	PAGE NUMBER
A	05/19	Obsolete CERDIP package	2, 14

**PACKAGE DESCRIPTION**

**N Package**  
**8-Lead PDIP (Narrow .300 Inch)**  
 (Reference LTC DWG # 05-08-1510 Rev I)

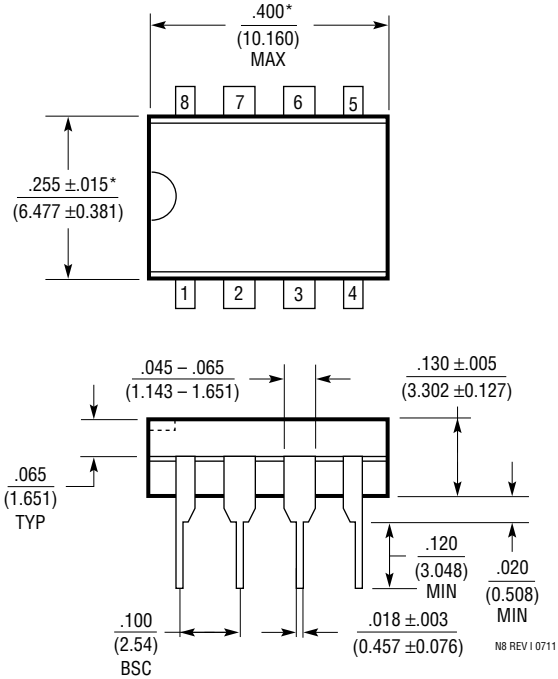

NOTE:  
 1. DIMENSIONS ARE  $\frac{\text{INCHES}}{\text{MILLIMETERS}}$   
 \*THESE DIMENSIONS DO NOT INCLUDE MOLD FLASH OR PROTRUSIONS.  
 MOLD FLASH OR PROTRUSIONS SHALL NOT EXCEED .010 INCH (0.254mm)

## Looking for pricing, stock, or lifecycle information?

Click below to explore more details on WIN SOURCE:

 [View LTC1044CN8 on WIN SOURCE](#)

 [Linear Technology](#) Information

## Optimize Your Supply Chain with WIN SOURCE Solutions

-  Global Sourcing Solution
-  Obsolete Management
-  Cost Control Management
-  Shortage Management
-  Alternative Solution
-  Excess Inventory Management