



**THE DATASHEET OF  
LTC1267CG-ADJ**



## Dual High Efficiency Synchronous Step-Down Switching Regulators

### OBSELETE:

FOR INFORMATION PURPOSES ONLY  
 Contact Linear Technology for Potential Replacement

## FEATURES

- **Dual Outputs: 3.3V and 5V, Two Adjustables or Adjustable and 5V**
- **Wide  $V_{IN}$  Range: 4V to 40V**
- **Ultra-High Efficiency: Up to 95%**
- **Low Supply Current in Shutdown: 20 $\mu$ A**
- Current Mode Operation for Excellent Line and Load Transient Response
- High Efficiency Maintained Over a Wide Output Current Range
- Independent Micropower Shutdown
- Very Low Dropout Operation: 100% Duty Cycle
- Synchronous FET Switching for High Efficiency
- Available in Standard 28-Pin SSOP

## APPLICATIONS

- Notebook and Palmtop Computers
- Battery-Operated Digital Devices
- Portable Instruments
- DC Power Distribution Systems

## DESCRIPTION

The LTC<sup>®</sup>1267 series are dual synchronous step-down switching regulator controllers featuring automatic Burst Mode<sup>™</sup> operation to maintain high efficiencies at low output currents. The LTC1267 is composed of two separate regulator blocks, each driving a pair of external complementary power MOSFETs at switching frequencies up to 400kHz. The LTC1267 uses a constant off-time current-mode architecture to provide constant ripple current in the inductor and provide excellent line and load transient response.

A separate pin and on-board switch allow the MOSFET driver power to be derived from the regulated output voltage, providing significant efficiency improvement when operating at high input voltage. The output current level is user-programmable via an external current sense resistor.

The LTC1267 series is ideal for applications requiring dual output voltages with high conversion efficiencies over a wide load current range in a small amount of board space.

**LT**, LTC and LT are registered trademarks of Linear Technology Corporation.  
 Burst Mode is a trademark of Linear Technology Corporation.

## TYPICAL APPLICATION

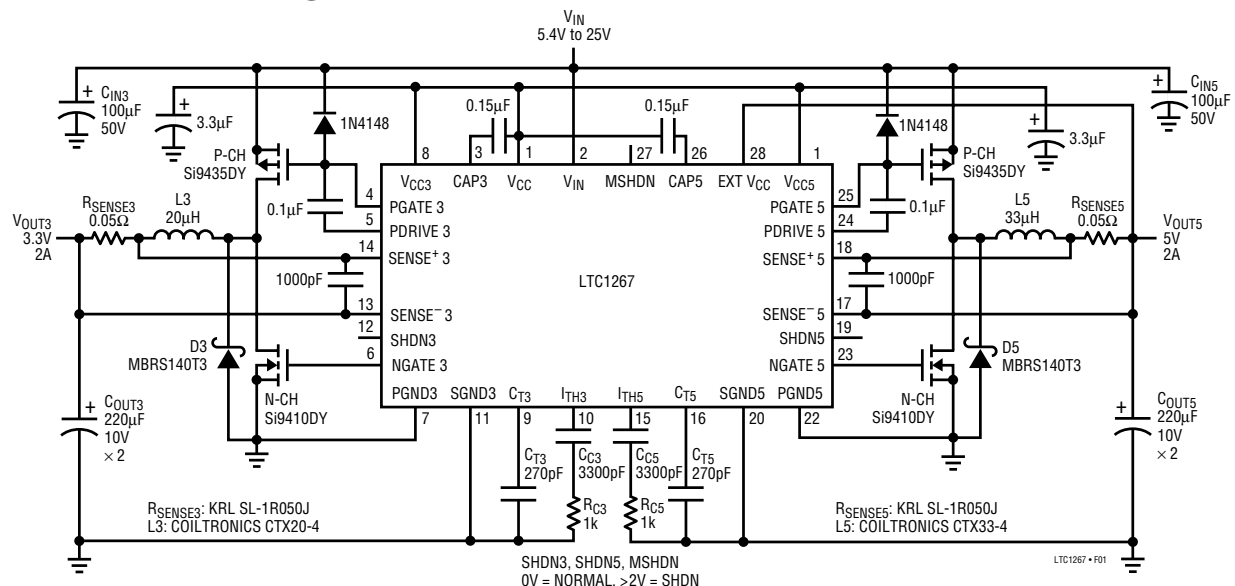

Figure 1. High Efficiency Dual 3.3V, 5V

## Looking for pricing, stock, or lifecycle information?

Click below to explore more details on WIN SOURCE:

 [View LTC1267CG-ADJ on WIN SOURCE](#)

 [Analog Devices Inc. Information](#)

## Optimize Your Supply Chain with WIN SOURCE Solutions

-  Global Sourcing Solution
-  Obsolete Management
-  Cost Control Management
-  Shortage Management
-  Alternative Solution
-  Excess Inventory Management