



**THE DATASHEET OF
LTC1400CS8#PBF**



FEATURES

- Complete 12-Bit ADC in SO-8
- Single Supply 5V or $\pm 5V$ Operation
- Sample Rate: 400ksps
- Power Dissipation: 75mW (Typ)
- 72dB S/(N + D) and -80 dB THD at Nyquist
- No Missing Codes over Temperature
- Nap Mode with Instant Wake-Up: 6mW
- Sleep Mode: 30 μ W
- High Impedance Analog Input
- Input Range (1mV/LSB): 0V to 4.096V or $\pm 2.048V$
- Internal Reference Can Be Overdriven Externally
- 3-Wire Interface to DSPs and Processors (SPI and MICROWIRE™ Compatible)

APPLICATIONS

- High Speed Data Acquisition
- Digital Signal Processing
- Multiplexed Data Acquisition Systems
- Audio and Telecom Processing
- Digital Radio
- Spectrum Analysis
- Low Power and Battery-Operated Systems
- Handheld or Portable Instruments

DESCRIPTION

The LTC[®]1400 is a complete 400ksps, 12-bit A/D converter which draws only 75mW from 5V or $\pm 5V$ supplies. This easy-to-use device comes complete with a 200ns sample-and-hold and a precision reference. Unipolar and bipolar conversion modes add to the flexibility of the ADC. The LTC1400 has two power saving modes: Nap and Sleep. In Nap mode, it consumes only 6mW of power and can wake up and convert immediately. In the Sleep mode, it consumes 30 μ W of power typically. Upon power-up from Sleep mode, a reference ready (REFRDY) signal is available in the serial data word to indicate that the reference has settled and the chip is ready to convert.

The LTC1400 converts 0V to 4.096V unipolar inputs from a single 5V supply and $\pm 2.048V$ bipolar inputs from $\pm 5V$ supplies. Maximum DC specs include ± 1 LSB INL, ± 1 LSB DNL and 45ppm/ $^{\circ}$ C drift over temperature. Guaranteed AC performance includes 70dB S/(N + D) and -76 dB THD at an input frequency of 100kHz, over temperature.

The 3-wire serial port allows compact and efficient data transfer to a wide range of microprocessors, microcontrollers and DSPs.

LT, **LT**, **LTC** and **LTM** are registered trademarks of Linear Technology Corporation. All other trademarks are the property of their respective owners.

TYPICAL APPLICATION

Single 5V Supply, 400kHz, 12-Bit Sampling A/D Converter

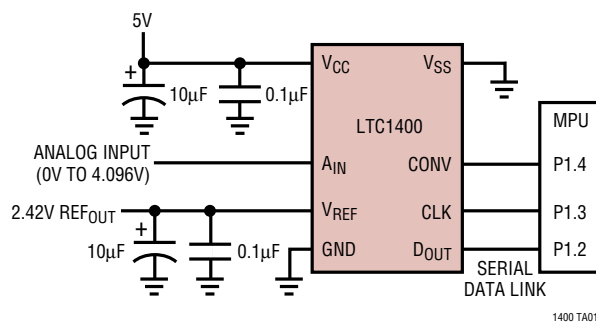

Power Consumption vs Sample Rate

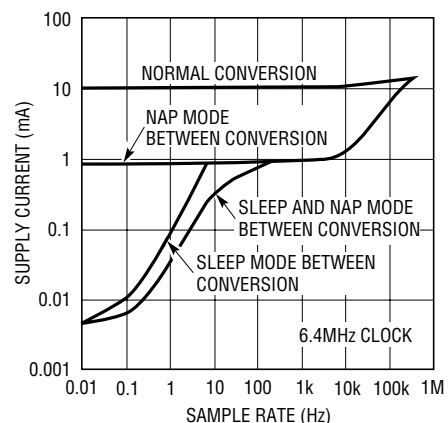

1400 TA02

ABSOLUTE MAXIMUM RATINGS

(Note 1, 2)

Supply Voltage (V_{CC})	7V
Negative Supply Voltage (V_{SS})	-6V to GND
Total Supply Voltage (V_{CC} to V_{SS})	
Bipolar Operation Only	12V
Analog Input Voltage (Note 3)	
Unipolar Operation	-0.3V to ($V_{CC} + 0.3V$)
Bipolar Operation	($V_{SS} - 0.3V$) to ($V_{CC} + 0.3V$)
Digital Input Voltage (Note 4)	
Unipolar Operation	-0.3V to 12V
Bipolar Operation	($V_{SS} - 0.3V$) to 12V
Digital Output Voltage	
Unipolar Operation	-0.3V to ($V_{CC} + 0.3V$)
Bipolar Operation	($V_{SS} - 0.3V$) to ($V_{CC} + 0.3V$)
Power Dissipation	500mW
Operation Temperature Range	
LTC1400C	0°C to 70°C
LTC1400I	-40°C to 85°C
Storage Temperature Range	-65°C to 150°C
Lead Temperature (Soldering, 10 sec)	300°C

PACKAGE/ORDER INFORMATION

<p>TOP VIEW</p> <p>S8 PACKAGE 8-LEAD PLASTIC SO $T_{JMAX} = 150^{\circ}C, \theta_{JA} = 130^{\circ}C/W$</p>	
ORDER PART NUMBER	S8 PART MARKING
LTC1400CS8	1400
LTC1400IS8	1400I
<p>Order Options Tape and Reel: Add #TR Lead Free: Add #PBF Lead Free Tape and Reel: Add #TRPBF Lead Free Part Marking: http://www.linear.com/leadfree/</p>	

Consult LTC Marketing for parts specified with wider operating temperature ranges.

POWER REQUIREMENTS

The ● denotes the specifications which apply over the full operating temperature range, otherwise specifications are at $T_A = 25^{\circ}C$ unless otherwise noted. (Note 5)

SYMBOL	PARAMETER	CONDITIONS	MIN	TYP	MAX	UNITS
V_{CC}	Positive Supply Voltage (Note 6)	Unipolar	4.75		5.25	V
		Bipolar	4.75		5.25	V
V_{SS}	Negative Supply Voltage (Note 6)	Bipolar Only	-2.45		-5.25	V
I_{CC}	Positive Supply Current	$f_{SAMPLE} = 400ksp/s$	●	15	30	mA
		Nap Mode	●	1.0	3.0	mA
		Sleep Mode	●	5.0	20.0	μA
I_{SS}	Negative Supply Current	$f_{SAMPLE} = 400ksp/s, V_{SS} = -5V$	●	0.3	0.6	mA
		Nap Mode	●	0.2	0.5	mA
		Sleep Mode	●	1	5	μA
P_D	Power Dissipation	$f_{SAMPLE} = 400ksp/s$	●	75	160	mW
		Nap Mode	●	6	20	mW
		Sleep Mode	●	30	125	μW

ANALOG INPUT

The ● denotes the specifications which apply over the full operating temperature range, otherwise specifications are at $T_A = 25^{\circ}C$ unless otherwise noted. (Note 5)

SYMBOL	PARAMETER	CONDITIONS	MIN	TYP	MAX	UNITS
V_{IN}	Analog Input Range (Note 7)	$4.75V \leq V_{CC} \leq 5.25V$ (Unipolar)	●	0 to 4.096		V
		$4.75V \leq V_{CC} \leq 5.25V, -5.25V \leq V_{SS} \leq -2.45V$ (Bipolar)	●	± 2.048		V
I_{IN}	Analog Input Leakage Current	During Conversions (Hold Mode)	●		± 1	μA
C_{IN}	Analog Input Capacitance	Between Conversions (Sample Mode)		45		pF
		During Conversions (Hold Mode)		5		pF

CONVERTER CHARACTERISTICS

The ● denotes the specifications which apply over the full operating temperature range, otherwise specifications are at $T_A = 25^\circ\text{C}$ unless otherwise noted. With internal reference (Notes 5, 8)

PARAMETER	CONDITIONS	MIN	TYP	MAX	UNITS
Resolution (No Missing Codes)	●	12			Bits
Integral Linearity Error	(Note 9) ●			±1	LSB
Differential Linearity Error	●			±1	LSB
Offset Error	(Note 10) ●			±6 ±8	LSB LSB
Full-Scale Error				±15	LSB
Full-Scale Tempco	$I_{OUT(REF)} = 0$ ●		±10	±45	ppm/°C

DYNAMIC ACCURACY

The ● denotes the specifications which apply over the full operating temperature range, otherwise specifications are at $T_A = 25^\circ\text{C}$. $V_{CC} = 5\text{V}$, $V_{SS} = -5\text{V}$, $f_{SAMPLE} = 400\text{kHz}$ unless otherwise noted. (Note 5)

SYMBOL	PARAMETER	CONDITIONS	MIN	TYP	MAX	UNITS
S/(N + D)	Signal-to-Noise Plus Distortion Ratio	100kHz Input Signal Commercial Industrial ●	70	72		dB
		●	69			dB
		200kHz Input Signal		72		dB
THD	Total Harmonic Distortion Up to 5th Harmonic	100kHz Input Signal ●		-82	-76	dB
		200kHz Input Signal		-80		dB
	Peak Harmonic or Spurious Noise	100kHz Input Signal ●		-84	-76	dB
		200kHz Input Signal		-82		dB
IMD	Intermodulation Distortion	$f_{IN1} = 99.51\text{kHz}$, $f_{IN2} = 102.44\text{kHz}$ ●		-82		dB
		$f_{IN1} = 199.12\text{kHz}$, $f_{IN2} = 202.05\text{kHz}$		-70		dB
	Full Power Bandwidth			4		MHz
	Full Linear Bandwidth (S/(N + D) ≥ 68dB)			900		kHz

INTERNAL REFERENCE CHARACTERISTICS

The ● denotes the specifications which apply over the full operating temperature range, otherwise specifications are at $T_A = 25^\circ\text{C}$ unless otherwise noted. (Note 5)

PARAMETER	CONDITIONS	MIN	TYP	MAX	UNITS
V_{REF} Output Voltage	$I_{OUT} = 0$	2.400	2.420	2.440	V
V_{REF} Output Tempco	$I_{OUT} = 0$ ●		±10	±45	ppm/°C
V_{REF} Load Regulation	$4.75\text{V} \leq V_{CC} \leq 5.25\text{V}$ $-5.25\text{V} \leq V_{SS} \leq 0\text{V}$		0.01 0.01		LSB/V LSB/V
V_{REF} Load Regulation	$0 \leq I_{OUT} \leq 1\text{mA}$		2		LSB/mA
V_{REF} Wake-Up Time from Sleep Mode (Note 7)	$C_{VREF} = 10\mu\text{F}$		4		ms

DIGITAL INPUTS AND DIGITAL OUTPUTS

The ● denotes the specifications which apply over the full operating temperature range, otherwise specifications are at $T_A = 25^\circ\text{C}$ unless otherwise noted. (Note 5)

SYMBOL	PARAMETER	CONDITIONS	MIN	TYP	MAX	UNITS
V_{IH}	High Level Input Voltage	$V_{CC} = 5.25\text{V}$ ●	2.0			V
V_{IL}	Low Level Input Voltage	$V_{CC} = 4.75\text{V}$ ●			0.8	V
I_{IN}	Digital Input Current	$V_{IN} = 0\text{V}$ to V_{CC} ●			±10	μA
C_{IN}	Digital Input Capacitance			5		pF
V_{OH}	High Level Output Voltage	$V_{CC} = 4.75\text{V}$, $I_O = -10\mu\text{A}$ ●		4.7		V
		$V_{CC} = 4.75\text{V}$, $I_O = -200\mu\text{A}$	4.0			V

1400fa

DIGITAL INPUTS AND DIGITAL OUTPUTS

The ● denotes the specifications which apply over the full operating temperature range, otherwise specifications are at $T_A = 25^\circ\text{C}$ unless otherwise noted. (Note 5)

SYMBOL	PARAMETER	CONDITIONS	MIN	TYP	MAX	UNITS
V_{OL}	Low Level Output Voltage	$V_{CC} = 4.75\text{V}, I_O = 160\mu\text{A}$		0.05		V
		$V_{CC} = 4.75\text{V}, I_O = 1.6\text{mA}$	●	0.10	0.4	V
I_{OZ}	Hi-Z Output Leakage D_{OUT}	$V_{OUT} = 0\text{V to } V_{CC}$			±10	μA
C_{OZ}	Hi-Z Output Capacitance D_{OUT} (Note 7)			15		pF
I_{SOURCE}	Output Source Current	$V_{OUT} = 0\text{V}$		-10		mA
I_{SINK}	Output Sink Current	$V_{OUT} = V_{CC}$		10		mA

TIMING CHARACTERISTICS

The ● denotes the specifications which apply over the full operating temperature range, otherwise specifications are at $T_A = 25^\circ\text{C}$ unless otherwise noted. (Note 5)

SYMBOL	PARAMETER	CONDITIONS	MIN	TYP	MAX	UNITS
$f_{SAMPLE(MAX)}$	Maximum Sampling Frequency	(Note 6)	●	400		kHz
t_{CONV}	Conversion Time	$f_{CLK} = 6.4\text{MHz}$	●		2.1	μs
t_{ACQ}	Acquisition Time (Unipolar Mode) (Bipolar Mode $V_{SS} = -5\text{V}$)	(Note 7)	●	230	300	ns
			●	200	270	ns
f_{CLK}	CLK Frequency		●	0.1	6.4	MHz
t_{CLK}	CLK Pulse Width	(Notes 7, 12)	●	50		ns
$t_{WK(NAP)}$	Time to Wake Up from Nap Mode	(Note 7)		350		ns
t_1	CLK Pulse Width to Return to Active Mode		●	50		ns
t_2	CONV↑ to CLK↑ Setup Time		●	80		ns
t_3	CONV↑ After Leading CLK↑		●	0		ns
t_4	CONV Pulse Width	(Note 11)	●	50		ns
t_5	Time from CLK↑ to Sample Mode	(Note 7)		80		ns
t_6	Aperture Delay of Sample-and-Hold	Jitter < 50ps (Note 7)	●	45	65	ns
t_7	Minimum Delay Between Conversion (Unipolar Mode) (Bipolar Mode $V_{SS} = -5\text{V}$)		●	265	385	ns
			●	235	355	ns
t_8	Delay Time, CLK↑ to D_{OUT} Valid	$C_{LOAD} = 20\text{pF}$	●	40	80	ns
t_9	Delay Time, CLK↑ to D_{OUT} Hi-Z	$C_{LOAD} = 20\text{pF}$	●	40	80	ns
t_{10}	Time from Previous Data Remains Valid After CLK↑	$C_{LOAD} = 20\text{pF}$	●	14	25	ns
t_{11}	Minimum Time between Nap/Sleep Request to Wake Up Request	(Notes 7, 12)	●	50		ns

Note 1: Stresses beyond those listed under Absolute Maximum Ratings may cause permanent damage to the device. Exposure to any Absolute Maximum Rating condition for extended periods may affect device reliability and lifetime.

Note 2: All voltage values are with respect to GND.

Note 3: When these pin voltages are taken below V_{SS} (ground for unipolar mode) or above V_{CC} , they will be clamped by internal diodes. This product can handle input currents greater than 40mA below V_{SS} (ground for unipolar mode) or above V_{CC} without latch-up.

Note 4: When these pin voltages are taken below V_{SS} (ground for unipolar mode), they will be clamped by internal diodes. This product can handle input currents greater than 40mA below V_{SS} (ground for unipolar mode) without latch-up. These pins are not clamped to V_{CC} .

Note 5: $V_{CC} = 5\text{V}$, $f_{SAMPLE} = 400\text{kHz}$, $t_r = t_f = 5\text{ns}$ unless otherwise specified.

Note 6: Recommended operating conditions.

Note 7: Guaranteed by design, not subject to test.

Note 8: Linearity, offset and full-scale specifications apply for unipolar and bipolar modes.

Note 9: Integral nonlinearity is defined as the deviation of a code from a straight line passing through the actual endpoints of the transfer curve. The deviation is measured from the center of the quantization band.

Note 10: Bipolar offset is the offset voltage measured from -0.5LSB when the output code flickers between 0000 0000 0000 and 1111 1111 1111.

Note 11: The rising edge of CONV starts a conversion. If CONV returns low at a bit decision point during the conversion, it can create small errors. For best performance ensure that CONV returns low either within 120ns after conversion starts (i.e., before the first bit decision) or after the 14 clock cycle. (Figure 13 Timing Diagram).

Note 12: If this timing specification is not met, the device may not respond to a request for a conversion. To recover from this condition a NAP request is required.

TYPICAL PERFORMANCE CHARACTERISTICS

Differential Nonlinearity vs Output Code

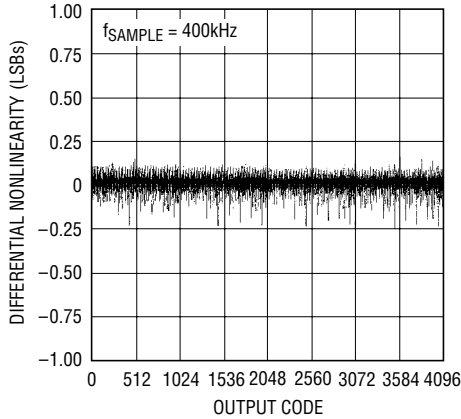

1400 TPC01

Integral Nonlinearity vs Output Code

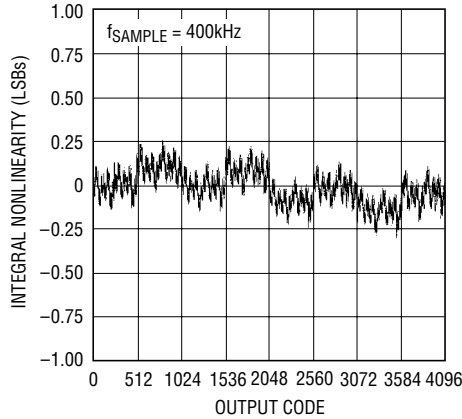

1400 TPC02

S/(N + D) vs Input Frequency and Amplitude

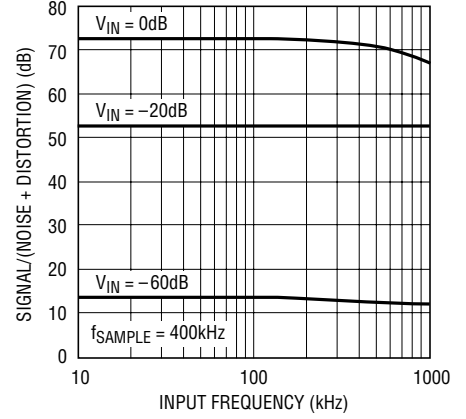

1400 TPC06

Signal-to-Noise Ratio (Without Harmonics) vs Input Frequency

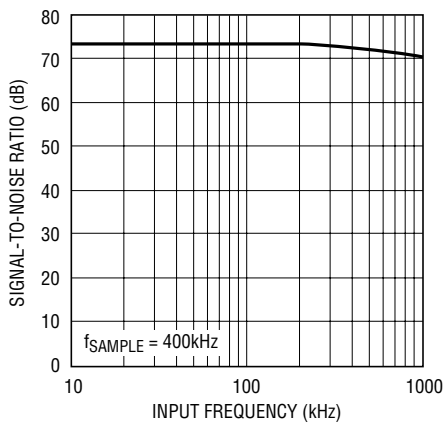

1400 TPC07

Peak Harmonic or Spurious Noise vs Input Frequency

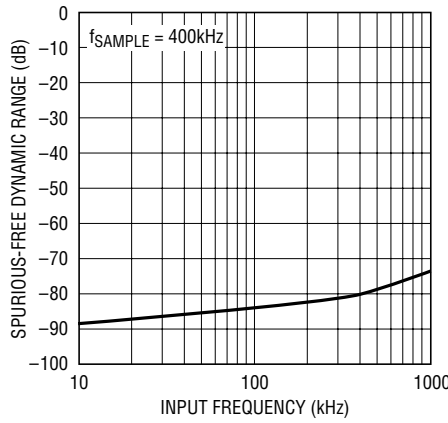

1400 TPC08

Acquisition Time vs Source Impedance

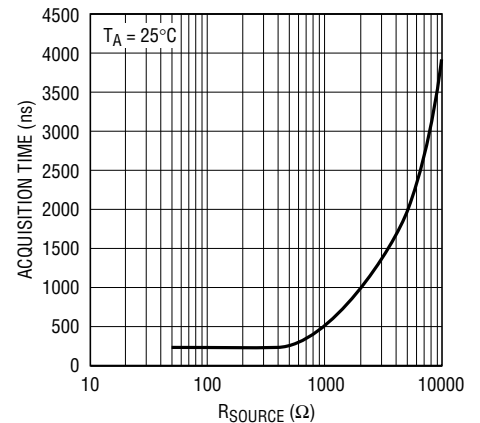

1400 TPC05

Reference Voltage vs Load Current

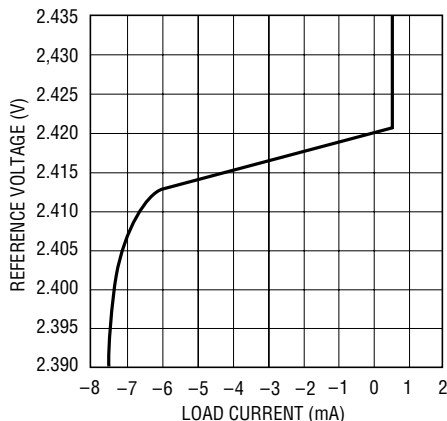

1400 TPC03

Power Supply Feedthrough vs Ripple Frequency

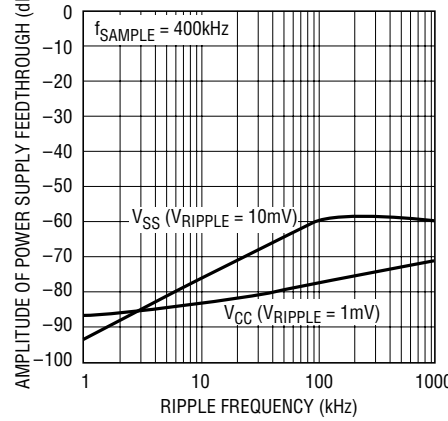

1400 TPC07.5

Supply Current vs Temperature

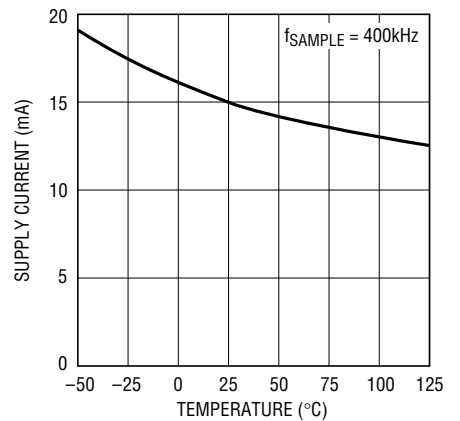

1400 TPC04

PIN FUNCTIONS

V_{CC} (Pin 1): Positive Supply, 5V. Bypass to GND (10 μ F tantalum in parallel with 0.1 μ F ceramic).

A_{IN} (Pin 2): Analog Input. 0V to 4.096V (Unipolar), ± 2.048 V (Bipolar).

V_{REF} (Pin 3): 2.42V Reference Output. Bypass to GND (10 μ F tantalum in parallel with 0.1 μ F ceramic).

GND (Pin 4): Ground. GND should be tied directly to an analog ground plane.

D_{OUT} (Pin 5): The A/D conversion result is shifted out from this pin.

CLK (Pin 6): Clock. This clock synchronizes the serial data transfer. A minimum CLK pulse of 50ns will cause the ADC to wake up from Nap or Sleep mode.

CONV (Pin 7): Conversion Start Signal. This active high signal starts a conversion on its rising edge. Keeping CLK low and pulsing CONV two/four times will put the ADC into Nap/Sleep mode.

V_{SS} (Pin 8): Negative Supply. -5V for bipolar operation. Bypass to GND with 0.1 μ F ceramic. V_{SS} should be tied to GND for unipolar operation.

FUNCTIONAL BLOCK DIAGRAM

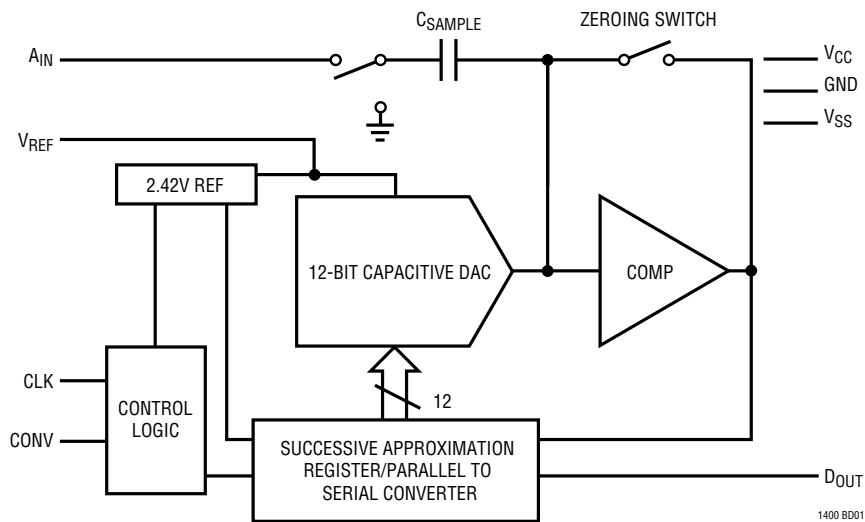

TEST CIRCUITS

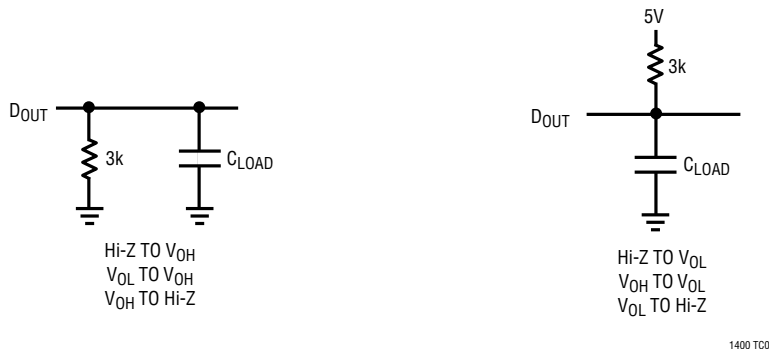

1400 TC01

APPLICATIONS INFORMATION

Conversion Details

The LTC1400 uses a successive approximation algorithm and an internal sample-and-hold circuit to convert an analog signal to a 12-bit serial output based on a precision internal reference. The control logic provides easy interface to microprocessors and DSPs through 3-wire connections.

A rising edge on the CONV input starts a conversion. At the start of a conversion the successive approximation register (SAR) is reset. Once a conversion cycle has begun it cannot be restarted.

During conversion, the internal 12-bit capacitive DAC output is sequenced by the SAR from the most significant bit (MSB) to the least significant bit (LSB). Referring to Figure 1, the A_{IN} input connects to the sample-and-hold capacitor during the acquire phase and the comparator offset is nulled by the feedback switch. In this acquire phase, it typically takes 200ns for the sample-and-hold capacitor to acquire the analog signal. During the convert phase, the comparator feedback switch opens, putting the comparator into the compare mode. The input switches connect C_{SAMPLE} to ground, injecting the analog input charge onto the summing junction. This input charge is successively compared with the binary-weighted charges supplied by the capacitive DAC. Bit decisions are made by the high speed comparator. At the end of a conversion, the DAC output balances the A_{IN} input charge. The SAR contents (a 12-bit data word) which represent the input voltage, are output through the serial pin D_{OUT} .

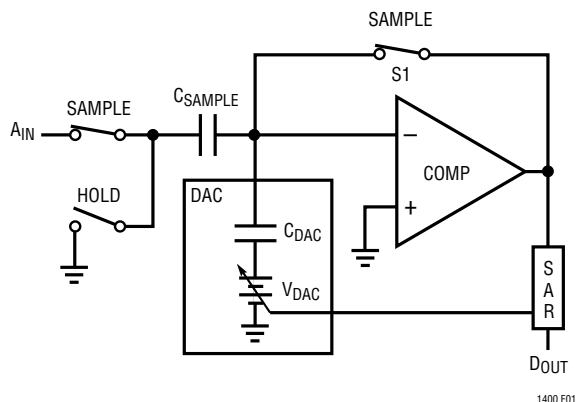

Figure 1. A_{IN} Input

Dynamic Performance

The LTC1400 has excellent high speed sampling capability. FFT (Fast Fourier Transform) test techniques are used to test the ADC's frequency response, distortion and noise at the rated throughput. By applying a low distortion sine wave and analyzing the digital output using an FFT algorithm, the ADC's spectral content can be examined for frequencies outside the fundamental. Figure 2a shows a typical LTC1400 FFT plot.

Signal-to-Noise Ratio

The signal-to-noise plus distortion ratio $[S/(N + D)]$ is the ratio between the RMS amplitude of the fundamental input frequency to the RMS amplitude of all other frequency components at the A/D output. The output is band limited to frequencies from DC to half the sampling frequency. Figure 2a shows a typical spectral content with a 400kHz sampling rate and a 100kHz input. The dynamic performance is excellent for input frequencies up to the Nyquist limit of 200kHz as shown in Figure 2b.

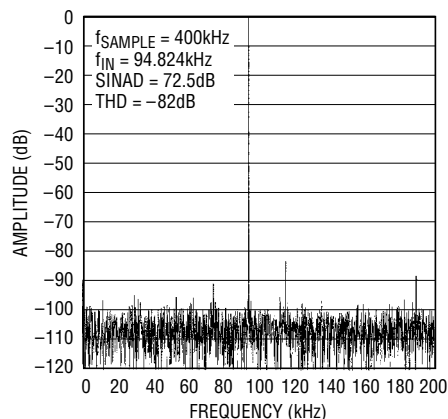

Figure 2a. LTC1400 Nonaveraged, 4096 Point FFT Plot with 100kHz Input Frequency in Bipolar Mode

Effective Number of Bits

The effective number of bits (ENOBs) is a measurement of the effective resolution of an ADC and is directly related to the $S/(N + D)$ by the equation:

$$N = \frac{S/(N+D) - 1.76}{6.02}$$

APPLICATIONS INFORMATION

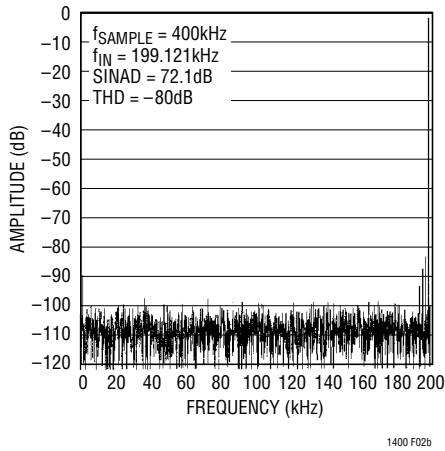

Figure 2b. LTC1400 Nonaveraged, 4096 Point FFT Plot with 200kHz Input Frequency in Bipolar Mode

where N is the effective number of bits of resolution and $S/(N + D)$ is expressed in dB. At the maximum sampling rate of 400kHz, the LTC1400 maintains very good ENOBs up to the Nyquist input frequency of 200kHz (refer to Figure 3).

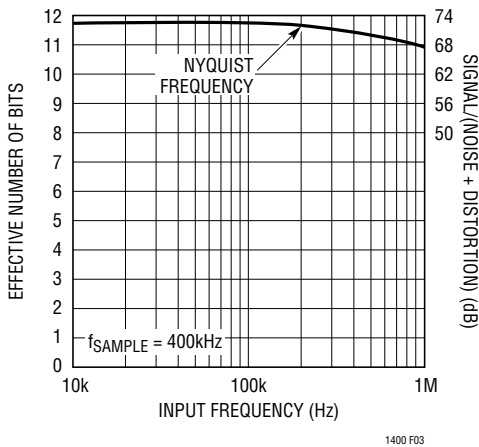

Figure 3. Effective Bits and Signal-to-Noise + Distortion vs Input Frequency in Bipolar Mode

Total Harmonic Distortion

Total harmonic distortion (THD) is the ratio of the RMS sum of all harmonics of the input signal to the fundamental itself. The out-of-band harmonics alias into the frequency band between DC and half of the sampling frequency. THD is expressed as:

$$THD = 20 \log \frac{\sqrt{V_2^2 + V_3^2 + V_4^2 + \dots + V_n^2}}{V_1}$$

where V_1 is the RMS amplitude of the fundamental frequency and V_2 through V_n are the amplitudes of the second through nth harmonics. THD vs input frequency is shown in Figure 4. The LTC1400 has good distortion performance up to the Nyquist frequency and beyond.

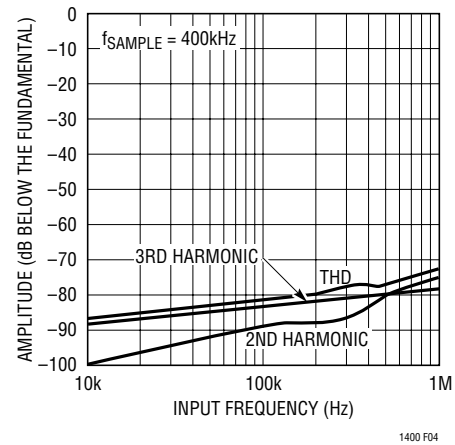

Figure 4. Distortion vs Input Frequency in Bipolar Mode

Intermodulation Distortion

If the ADC input signal consists of more than one spectral component, the ADC transfer function nonlinearity can produce intermodulation distortion (IMD) in addition to THD. IMD is the change in one sinusoidal input caused by the presence of another sinusoidal input at a different frequency.

If two pure sine waves of frequencies f_a and f_b are applied to the ADC input, nonlinearities in the ADC transfer function can create distortion products at sum and difference frequencies of $m f_a \pm n f_b$, where m and $n = 0, 1, 2, 3$, etc. For example, the 2nd order IMD terms include $(f_a + f_b)$ and $(f_a - f_b)$ while the 3rd order IMD terms includes $(2f_a + f_b)$, $(2f_a - f_b)$, $(f_a + 2f_b)$ and $(f_a - 2f_b)$. If the two input sine waves are equal in magnitude, the value (in decibels) of the 2nd order IMD products can be expressed by the following formula.

$$IMD(f_a \pm f_b) = 20 \log \frac{\text{Amplitude at } (f_a \pm f_b)}{\text{Amplitude at } f_a}$$

APPLICATIONS INFORMATION

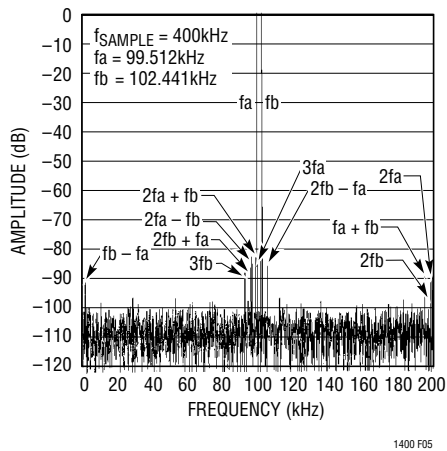

Figure 5. Intermodulation Distortion Plot in Bipolar Mode

Figure 5 shows the IMD performance at a 100kHz input.

Peak Harmonic or Spurious Noise

The peak harmonic or spurious noise is the largest spectral component excluding the input signal and DC. This value is expressed in decibels relative to the RMS value of a full-scale input signal.

Full Power and Full Linear Bandwidth

The full power bandwidth is the input frequency at which the amplitude of the reconstructed fundamental is reduced by 3dB for a full-scale input signal.

The full linear bandwidth is the input frequency at which the $S/(N + D)$ has dropped to 68dB (11 effective bits). The LTC1400 has been designed to optimize input bandwidth, allowing the ADC to undersample input signals with frequencies above the converter's Nyquist Frequency. The noise floor stays very low at high frequencies; $S/(N + D)$ becomes dominated by distortion at frequencies far beyond Nyquist.

Driving the Analog Input

The analog input of the LTC1400 is easy to drive. It draws only one small current spike while charging the sample-and-hold capacitor at the end of a conversion. During conversion, the analog input draws only a small leakage current. The only requirement is that the amplifier driving the analog input must settle after the small current spike before the next conversion starts. Any op amp that

settles in 200ns to small load current transient will allow maximum speed operation. If a slower op amp is used, more settling time can be provided by increasing the time between conversions. Suitable devices capable of driving the ADC's A_{IN} input include the LT[®]1360 and the LT1363 op amps.

LTC1400 comes with a built-in unipolar/bipolar detection circuit. If V_{SS} potential is forced below GND, the internal circuitry will automatically switch to bipolar mode.

The following list is a summary of the op amps that are suitable for driving the LTC1400, more detailed information is available in the Linear Technology databooks or the Linear Technology Website.

LT1215/LT1216: Dual and quad 23MHz, 50V/ μ s single supply op amps. Single 5V to ± 15 V supplies, 6.6mA specifications, 90ns settling to 0.5LSB.

LT1223: 100MHz video current feedback amplifier. ± 5 V to ± 15 V supplies, 6mA supply current. Low distortion up to and above 400kHz. Low noise. Good for AC applications.

LT1227: 140MHz video current feedback amplifier. ± 5 V to ± 15 V supplies, 10mA supply current. Lowest distortion at frequencies above 400kHz. Low noise. Best for AC applications.

LT1229/LT1230: Dual and quad 100MHz current feedback amplifiers. ± 2 V to ± 15 V supplies, 6mA supply current each amplifier. Low noise. Good AC specs.

LT1360: 37MHz voltage feedback amplifier. ± 5 V to ± 15 V supplies. 3.8mA supply current. Good AC and DC specs. 70ns settling to 0.5LSB.

LT1363: 50MHz, 450V/ μ s op amps. ± 5 V to ± 15 V supplies. 6.3mA supply current. Good AC and DC specs. 60ns settling to 0.5LSB.

LT1364/LT1365: Dual and quad 50MHz, 450V/ μ s op amps. ± 5 V to ± 15 V supplies, 6.3mA supply current per amplifier. 60ns settling to 0.5LSB.

Internal Reference

The LTC1400 has an on-chip, temperature compensated, curvature corrected, bandgap reference, which is factory

APPLICATIONS INFORMATION

trimmed to 2.42V. It is internally connected to the DAC and is available at Pin 3 to provide up to 1mA of current to an external load. For minimum code transition noise, the reference output should be decoupled with a capacitor to filter wideband noise from the reference (10 μ F tantalum in parallel with a 0.1 μ F ceramic). The V_{REF} pin can be driven with a DAC or other means to provide input span adjustment in bipolar mode. The V_{REF} pin must be driven to at least 2.45V to prevent conflict with the internal reference. The reference should not be driven to more than 5V.

Figure 6 shows an LT1360 op amp driving the reference pin. Figure 7 shows a typical reference, the LT1019A-5 connected to the LTC1400. This will provide an improved drift (equal to the maximum 5ppm/ $^{\circ}$ C of the LT1019A-5) and a ± 4.231 V full scale. If V_{REF} is forced lower than 2.42V, the REFRDY bit in the serial data output will be forced to low.

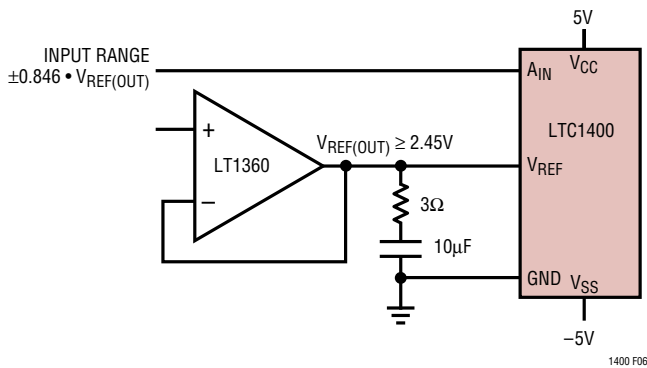

Figure 6. Driving the V_{REF} with the LT1360 Op Amp

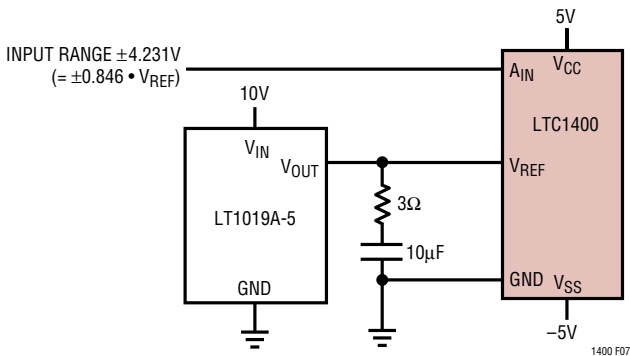

Figure 7. Supplying a 5V Reference Voltage to the LTC1400 with the LT1019A-5

Unipolar/Bipolar Operation and Adjustment

Figure 8 shows the ideal input/output characteristics for the LTC1400. The code transitions occur midway between successive integer LSB values (i.e., 0.5LSB, 1.5LSB, 2.5LSB, ... FS – 1.5LSB). The output code is straight binary with 1LSB = 4.096V/4096 = 1mV. Figure 9 shows the input/output transfer characteristics for the bipolar mode in two's complement format.

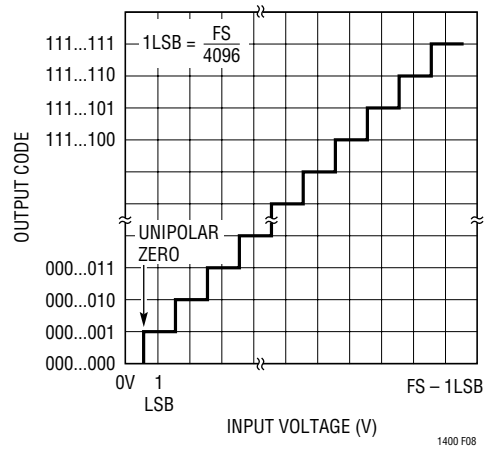

Figure 8. LTC1400 Unipolar Transfer Characteristics

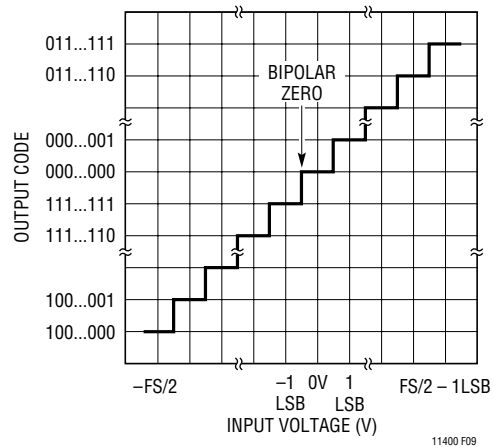

Figure 9. LTC1400 Bipolar Transfer Characteristics

Unipolar Offset and Full-Scale Error Adjustments

In applications where absolute accuracy is important, offset and full-scale errors can be adjusted to zero. Figure 10a shows the extra components required for full-scale

APPLICATIONS INFORMATION

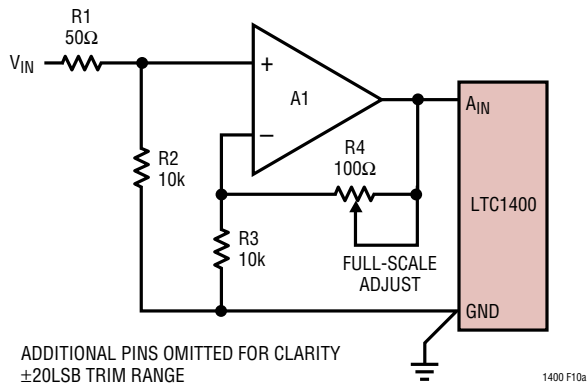

Figure 10a. LTC1400 Full-Scale Adjust Circuit

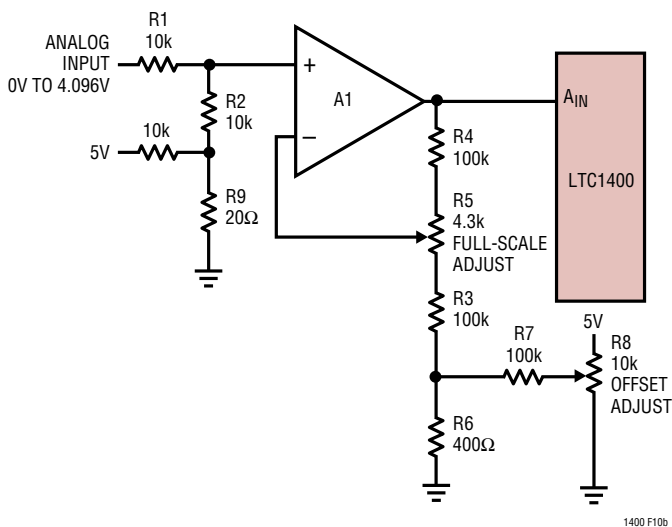

Figure 10b. LTC1400 Offset and Full-Scale Adjust Circuit

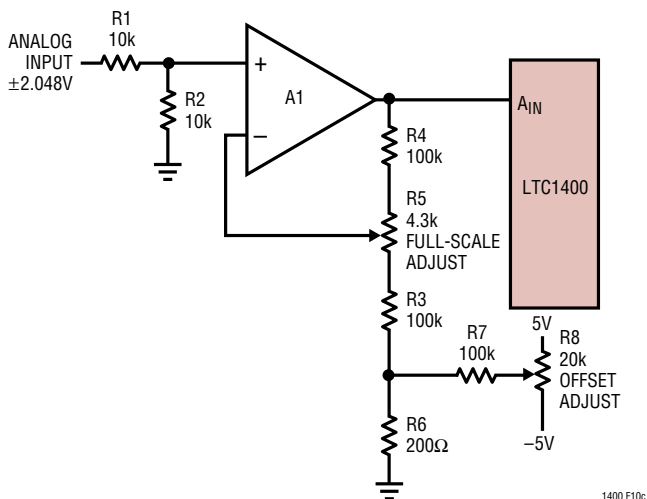

Figure 10c. LTC1400 Bipolar Offset and Full-Scale Adjust Circuit

error adjustment. Figure 10b shows offset and full-scale adjustment. Offset error must be adjusted before full-scale error. Zero offset is achieved by applying 0.5mV (i.e., 0.5LSB) at the input and adjusting the offset trim until the LTC1400 output code flickers between 0000 0000 and 0000 0000 0001. For zero full-scale error, apply an analog input of 4.0945V (FS – 1.5LSB or last code transition) at the input and adjust R5 until the LTC1400 output code flickers between 1111 1111 1110 and 1111 1111 1111.

Bipolar Offset and Full-Scale Error Adjustments

Bipolar offset and full-scale errors are adjusted in a similar fashion to the unipolar case. Bipolar offset error adjustment is achieved by applying an input voltage of –0.5mV (–0.5LSB) to the input in Figure 10c and adjusting the op amp until the ADC output code flickers between 0000 0000 and 1111 1111 1111. For full-scale adjustment, an input voltage of 2.0465V (FS – 1.5LSBs) is applied to the input and R5 is adjusted until the output code flickers between 0111 1111 1110 and 0111 1111 1111.

Board Layout and Bypassing

To obtain the best performance from the LTC1400, a printed circuit board is required. Layout for the printed circuit board should ensure that digital and analog signal lines are separated as much as possible. In particular, care should be taken not to run any digital track alongside an analog signal track or underneath the ADC. The analog input should be screened by GND.

High quality tantalum and ceramic bypass capacitors should be used at the V_{CC} and V_{REF} pins as shown in the Typical Application on the first page of this data sheet. For the bipolar mode, a 0.1 μ F ceramic provides adequate bypassing for the V_{SS} pin. For optimum performance, a 10 μ F surface mount AVX capacitor with a 0.1 μ F ceramic is recommended for the V_{CC} and V_{REF} pins. The capacitors must be located as close to the pins as possible. The traces connecting the pins and the bypass capacitors must be kept short and should be made as wide as possible. In unipolar mode operation, V_{SS} should be isolated from any noise source before shorting to the GND pin.

APPLICATIONS INFORMATION

Input signal leads to A_{IN} and signal return leads from GND (Pin 4) should be kept as short as possible to minimize noise coupling. In applications where this is not possible, a shielded cable between source and ADC is recommended. Also, since any potential difference in grounds between the signal source and ADC appears as an error voltage in series with the input signal, attention should be paid to reducing the ground circuit impedance as much as possible.

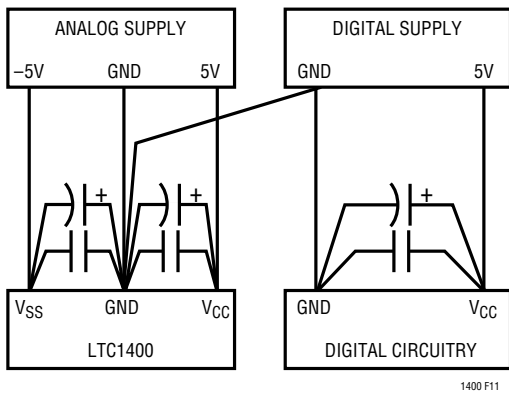

Figure 11. Power Supply Connection

Figure 11 shows the recommended system ground connections. All analog circuitry grounds should be terminated at

the LTC1400 GND pin. The ground return from the LTC1400 Pin 4 to the power supply should be low impedance for noise free operation. Digital circuitry grounds must be connected to the digital supply common.

In applications where the ADC data outputs and control signals are connected to a continuously active microprocessor bus, it is possible to get errors in the conversion results. These errors are due to feedthrough from the microprocessor to the successive approximation comparator. The problem can be eliminated by forcing the microprocessor into a Wait state during conversion or by using three-state buffers to isolate the ADC data bus.

Power-Down Mode

Upon power-up, the LTC1400 is initialized to the active state and is ready for conversion. However, the chip can be easily placed into the Nap or Sleep mode by exercising the right combination of CLK and CONV signal. In the Nap mode all power is off except the internal reference, which is still active and provides 2.42V output voltage to the other circuitry. In this mode, the ADC draws only 6mW of power instead of 75mW (for minimum power, the logic inputs must be within 500mV of the supply rails). The wake-up time from the Nap mode to the active mode is 350ns.

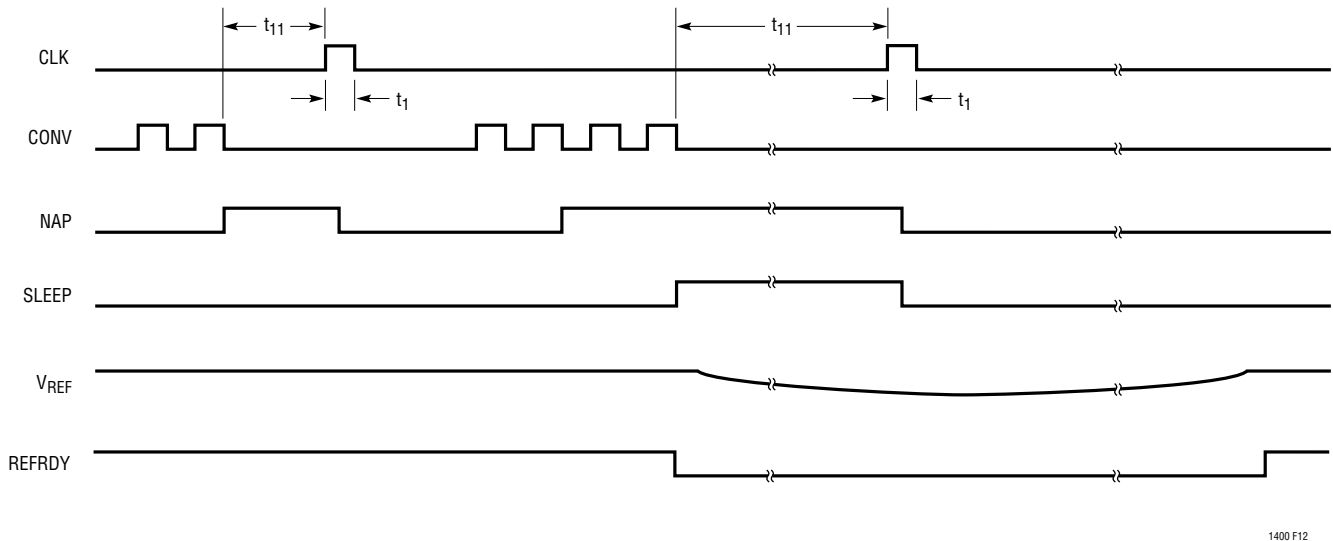

NOTE: NAP AND SLEEP ARE INTERNAL SIGNALS. REFRDY APPEARS AS A BIT IN THE D_{OUT} WORD.

Figure 12. Nap Mode and Sleep Mode Waveforms

APPLICATIONS INFORMATION

In the Sleep mode, power consumption is reduced to a minimum by cutting off the supply to all internal circuitry including the reference. Figure 12 shows the ways to power down the LTC1400. The chip can enter the Nap mode by keeping the CLK signal low and pulsing the CONV signal twice. For Sleep mode operation, CONV signal should be pulsed four times while CLK is kept low.

The LTC1400 can be returned to active mode easily. The rising edge of CLK will wake-up the LTC1400. During the transition from Sleep mode to active mode, the V_{REF} voltage ramp-up time is a function of the loading conditions. With a $10\mu\text{F}$ bypass capacitor, the wake-up time from Sleep mode is typically 4ms. A REFRDY signal will be activated once the reference has settled and is ready for an A/D conversion. This REFRDY bit is output to the D_{OUT} pin before the rest of the A/D converted code.

Digital Interface

The digital interface requires only three digital lines. CLK and CONV are both inputs, and the D_{OUT} output provides the conversion result in serial form.

Figure 13 shows the digital timing diagram of the LTC1400 during the A/D conversion. The CONV rising edge starts the conversion. Once initiated, it can not be restarted until the conversion is completed. If the time from CONV signal to CLK rising edge is less than t_2 , the digital output will be delayed by one clock cycle.

The digital output data is updated on the rising edge of the CLK line. D_{OUT} data should be captured by the receiving system on the rising CLK edge. Data remains valid for a minimum time of t_{10} after the rising CLK edge to allow capture to occur.

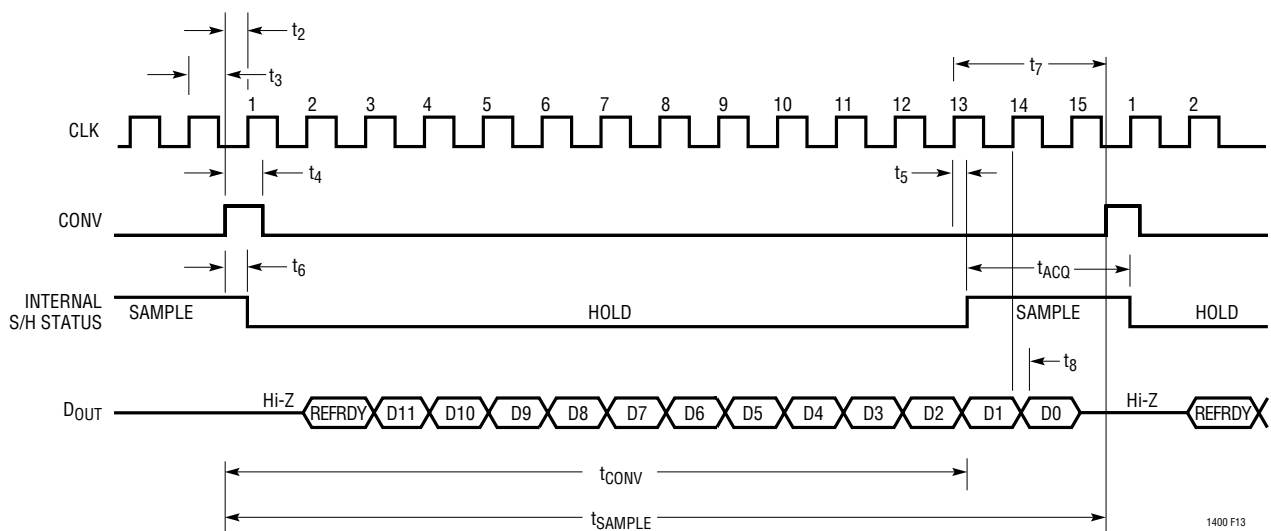

Figure 13. ADC Digital Timing Diagram

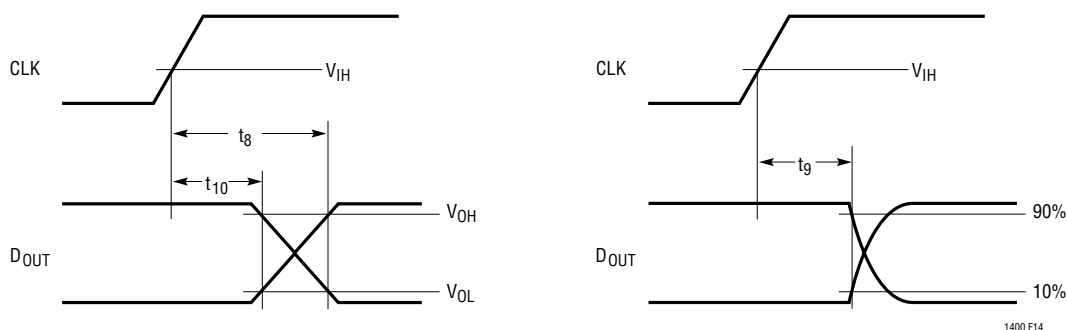
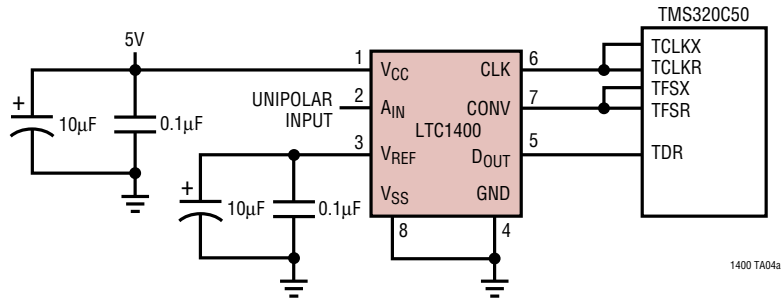

Figure 14. CLK to D_{OUT} Delay

TYPICAL APPLICATIONS

Hardware Interface to TMS320C50's TDM Serial Port (Frame Sync is Generated from TFSX)



Logic Analyzer Waveforms Show 3.2µs Throughput Rate (Input Voltage = 3.046V, Output Code = 1011 1110 0110 = 3046₁₀)

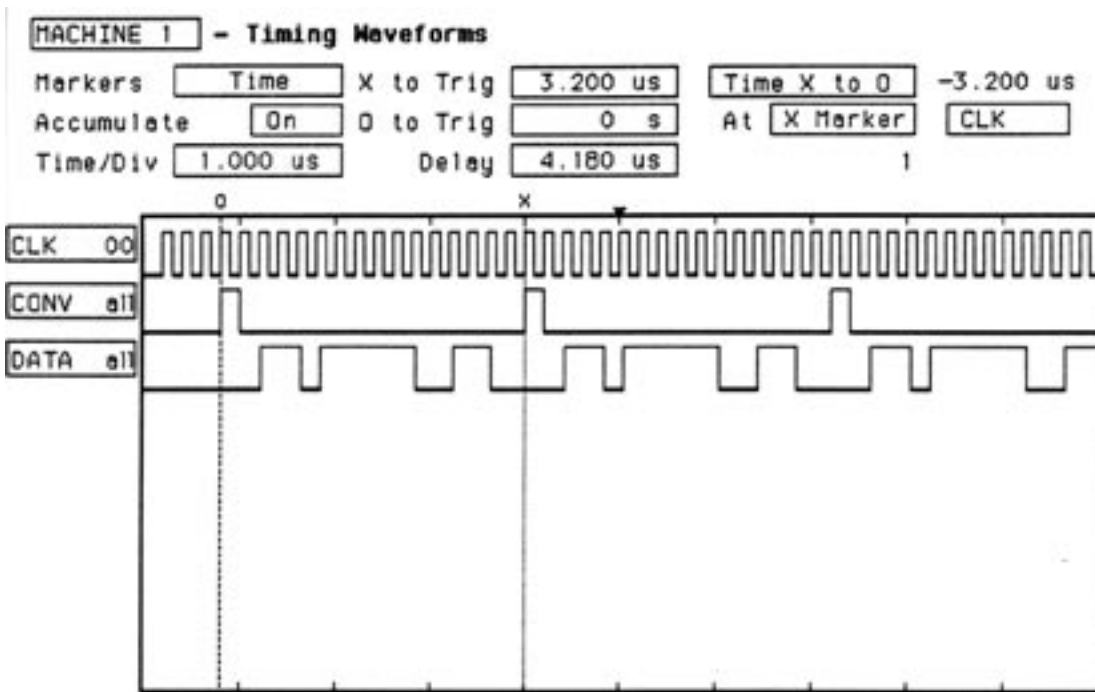

Data from LTC1400 Loaded into TMS320C50's TRCV Register

X	RDY	D11	D10	D9	D8	D7	D6	D5	D4	D3	D2	D1	D0	X	X
---	-----	-----	-----	----	----	----	----	----	----	----	----	----	----	---	---

1400 TA05c

Data Stored in TMS320C50's Memory (in Right Justified Format)

0	0	0	RDY	D11	D10	D9	D8	D7	D6	D5	D4	D3	D2	D1	D0
---	---	---	-----	-----	-----	----	----	----	----	----	----	----	----	----	----

1400 TA05d

TYPICAL APPLICATIONS

TMS320C50 Code for Circuit

THIS PROGRAM DEMONSTRATES LTC1400 INTERFACE TO TMS320C50 FRAME SYNC PULSE IS GENERATED FROM TFSX

```

*Initialization*
.mmregs                ; Defines global symbolic names
;- - Initialized data memory to zero
.ds    0F00h          ; Initialize data to zero
DATA0  .word  0        ; Begin sample data location
DATA1  .word  0        ;
DATA2  .word  0        ; Location of data
DATA3  .word  0        ;
DATA4  .word  0        ;
DATA5  .word  0        ; End sample data location
;- - Set up the ISR vector
.ps    080Ah          ; Serial ports interrupts
rint :   B    RECEIVE  ; 0A;
xint :   B    TRANSMIT ; 0C;
trnt :   B    TREC     ; 0E;
txnt :   B    TTRANX   ; 10;
;- - Setup the reset vector
.ps    0A00h
.entry
START:

*TMS320C50 Initialization*
SETC INTM              ; Temporarily disable all interrupts
LDP  #0                ; Set data page pointer to zero
OPL  #0834h, PMST     ; Set up the PMST status and control register
LACC #0
SAMM CWSR              ; Set software wait state to 0
SAMM PDWSR             ;

*Configure Serial Port*
SPLK #0038h, TSPC     ; Set TDM Serial Port
                    ; TDM = 0 Stand Alone mode
                    ; DLB = 0 Not loop back
                    ; FO = 0 16 Bits
                    ; FSM = 1 Burst Mode
                    ; MCM = 1 CLKX is generated internally
                    ; TXM = 1 FSX as output pin
                    ; Put serial port into reset
                    ; (XRST = RRST = 0)
SPLK #00F8h, TSPC     ; Take Serial Port out of reset
                    ; (XRST = RRST = 1)
SPLK #0FFFFh, IFR     ; Clear all the pending interrupts

```

```

*Start Serial Communication*
SACL TDXR              ; Generate frame sync pulse
SPLK #040h, IMR       ; Turn on TRNT receiver interrupt
CLRC INTM             ; Enable interrupt
CLRC SXM              ; For Unipolar input, set for right shift
                    ; with no sign extension
MAR  *AR7              ; Load the auxiliary register pointer with seven
LAR  AR7, #0F00h      ; Load the auxiliary register seven with #0F00h
                    ; as the begin address for data storage
WAIT: NOP              ; Wait for a receive interrupt
      NOP              ;
      NOP              ;
SACL TDXR              ; !! regenerate the frame sync pulse
B    WAIT              ;
;- - - - - end of main program - - - - -

```

Receiver Interrupt Service Routine

```

TREC:
LAMB TRCV              ; Load the data received from LTC1400
SFR                    ; Shift right two times
SFR                    ;
AND  #1FFFh, 0         ; ANDed with #1FFFh
                    ; For converting the data to right
                    ; justified format
                    ;
SACL *, 0              ; Write to data memory pointed by AR7 and
                    ; increase the memory address by one
LACC AR7               ;
SUB  #0F05h, 0         ; Compare to end sample address #0F05h
BCND END_TRCV, GEQ     ; If the end sample address has exceeded jump
                    ; to END_TRCV
                    ;
SPLK #040h, IMR       ; Else Re-enable the TRNT receive interrupt
RETE                    ; Return to main program and enable interrupt

```

After Obtained the Data from LTC1400, Program Jump to END_TRCV

```

END_TRCV:
SPLK #002h, IMR       ; Enable INT2 for program to halt
CLRC INTM
SUCCESS:
B    SUCCESS

```

Fill the Unused Interrupt with RETE, to avoid program get "lost"

```

TTRANX:
RETE
RECEIVE:
RETE
TRANSMIT:
RETE
INT2:
B halt                ; Halts the running CPU

```

TYPICAL APPLICATIONS

LTC1400 Interface to ADSP2181's SPORT0 (Frame Sync is Generated from RFS0)

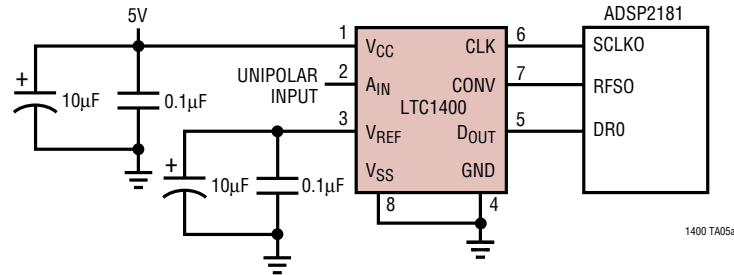

Logic Analyzer Waveforms Show 2.88µs Throughput Rate (Input Voltage = 2.240V, Output Code = 1000 1100 0000 = 2240₁₀)

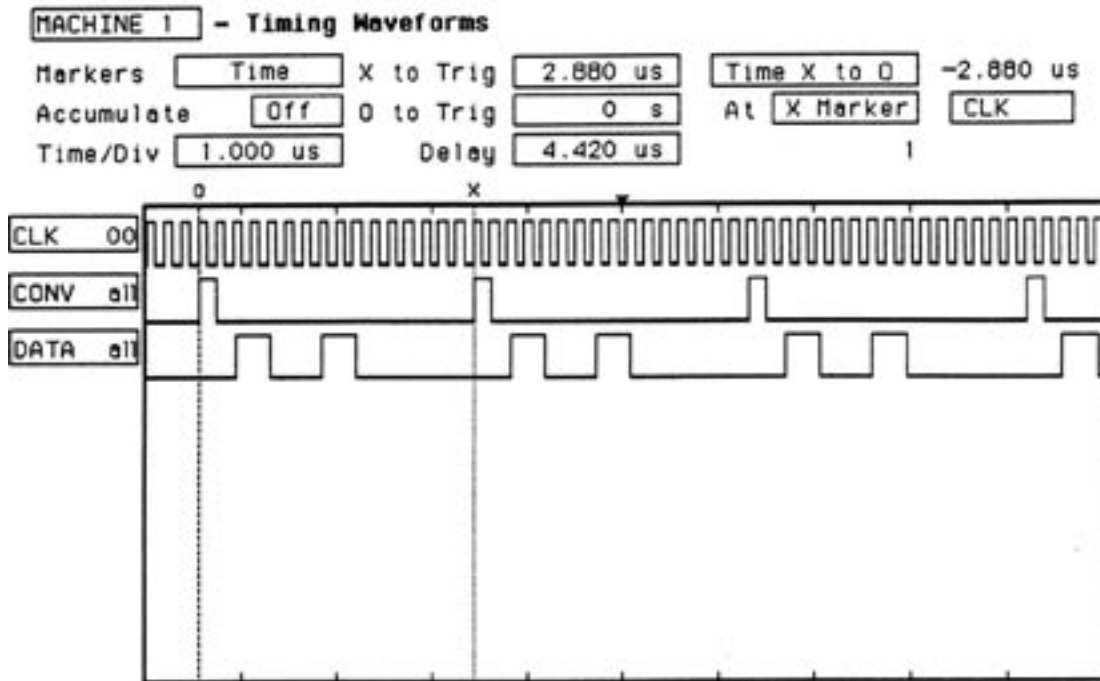

Data from LTC1400 (Normal Mode)

X	RDY	D11	D10	D9	D8	D7	D6	D5	D4	D3	D2	D1	D0	X	X
---	-----	-----	-----	----	----	----	----	----	----	----	----	----	----	---	---

1400 TA05c

Data Stored in ADSP2181's Memory (Normal Mode, SLEN = D)

0	0	0	RDY	D11	D10	D9	D8	D7	D6	D5	D4	D3	D2	D1	D0
---	---	---	-----	-----	-----	----	----	----	----	----	----	----	----	----	----

1400 TA05d

TYPICAL APPLICATIONS

ADSP2181 Code for Circuit

**THIS PROGRAM DEMONSTRATES LTC1400 INTERFACE TO ADSP-2181
FRAME SYNC PULSE IS GENERATED FROM RFS0**

```

/*Section 1: Initialization*/
.module/ram/abs = 0 adsp1tc; /*define the program module*/
jump start; /*jump over interrupt vectors*/
nop; nop; nop;
rti; rti; rti; rti; /*code vectors here upon IRQ2 int*/
rti; rti; rti; rti; /*code vectors here upon IRQL1 int*/
rti; rti; rti; rti; /*code vectors here upon IRQL0 int*/
rti; rti; rti; rti; /*code vectors here upon SPORT0 TX int*/
ax0 = rx0; /*Section 5*/
dm (0x2000) = ax0; /*begin of SPORT0 receive interrupt*/
rti; /* */
/* */
/*end of SPORT0 receive interrupt*/
rti; rti; rti; rti; /*code vectors here upon /IRQE int*/
rti; rti; rti; rti; /*code vectors here upon BDMA interrupt*/
rti; rti; rti; rti; /*code vectors here upon SPORT1 TX (IRQ1) int*/
rti; rti; rti; rti; /*code vectors here upon SPORT1 RX (IRQ0) int*/
rti; rti; rti; rti; /*code vectors here upon TIMER int*/
rti; rti; rti; rti; /*code vectors here upon POWER DOWN int*/

/*Section 2: Configure SPORT0*/
start:
/*to configure SPORT0 control reg*/
/*SPORT0 address = 0X3FF6*/
/*RFS is used for frame sync generation*/
/*RFS0 is internal, TFS is not use*/
/*bit 0-3 = Slen*/
/*F = 15 = 1111*/
/*E = 14 = 1110*/
/*D = 13 = 1101*/
/*bit 4,5 data type right justified zero filled MSB*/
/*bit 6 INVRFS = 0*/
/*bit 7 INVTFS = 0*/
/*bit 8 IRFS = 1 receive internal frame sync*/
/*bit 9,10,11 are for TFS (don't care)*/
/*bit 12 TFSW = 1 receive is Normal mode*/
/*bit 13 RTFS = 1 receive is framed mode*/
/*bit 14 ISCLK internal = 1*/
/*bit 15 multichannel mode = 0*/
ax0 = 0x6B0D; /*normal mode, bit12 = 0*/
/*if alternate mode bit12 = 1, ax0 = 0x7F0E*/

dm (0x3FF6) =ax0;

```

```

/*Section 3: configure CLKDIV and RFSDIV, setup interrupts*/
/*to configure CLKDIV reg*/
ax0 = 2;
dm(0x3FF5) = ax0; /*set the serial clock divide modulus reg
SCLKDIV*/
/*the input clock frequency = 16.67MHz*/
/*CLKOUT frequency = 2x = 33MHz*/
/*SCLK= 1/2*CLKOUT*/(SCLKDIV+1)*/
/*for SCLKDIV = 2, SCLK = 33/6 = 5.5MHz*/

/*to Configure RFSDIV*/
ax0 = 15; /*set the RFSDIV reg = 15*/
/* = > the frame sync pulse for every 16 SCLK*/
/*if frame sync pulse in every 15 SCLK, ax0 = 14*/

dm(0x3FF4) = ax0;
/*to setup interrupt*/
ifc = 0x0066; /*clear any extraneous SPORT interrupts*/
icntl = 0; /*IRQXB = level sensitivity*/
/*disable nesting interrupt*/

imask= 0x0020; /*bit 0 = timer int = 0*/
/*bit 1 = SPORT1 or IRQ0B int = 0*/
/*bit 2 = SPORT1 or IRQ1B int = 0*/
/*bit 3 = BDMA int = 0*/
/*bit 4 = IRQEB int = 0*/
/*bit 5 = SPORT0 receive int = 1*/
/*bit 6 = SPORT0 transmit int = 0*/
/*bit 7 = IRQ2B int = 0*/
/*enable SPORT0 receive interrupt*/

/*Section 4: Configure System Control Register and Start Communication*/
/*to configure system control reg*/
ax0 = dm(0x3FFF); /*read the system control reg*/
ay0 = 0xFFFF;
ar = ax0 AND ay0; /*set wait state to zero*/
ay0 = 0x1000;
ar = ar OR ay0; /*bit12 = 1, enable SPORT0*/
dm(0x3FFF) = ar;
/*frame sync pulse regenerated automatically*/
cntr = 5000;
do waitloop until ce;
nop;
nop;
nop;
nop;
nop;
nop;
nop;
waitloop: nop;
rts;
.endmod;

```

TYPICAL APPLICATIONS

Quick Look Circuit for Converting Data to Parallel Format

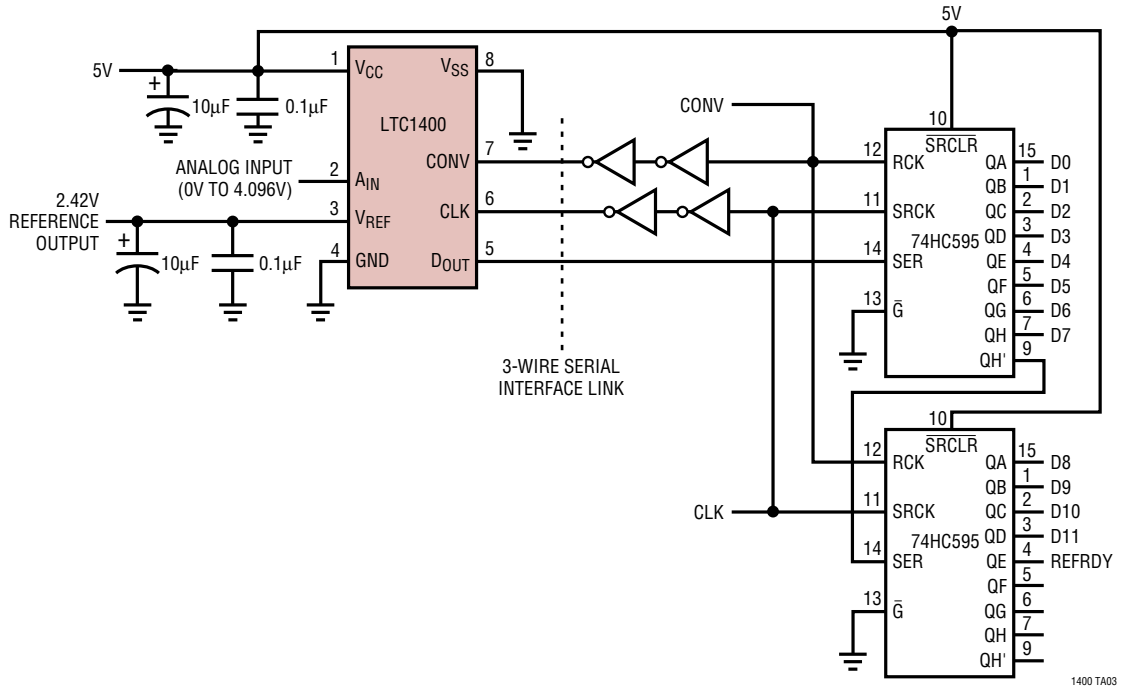

PACKAGE DESCRIPTION Dimensions in inches (millimeters) unless otherwise noted.

S8 Package 8-Lead Plastic Small Outline (Narrow 0.150) (LTC DWG # 05-08-1610)

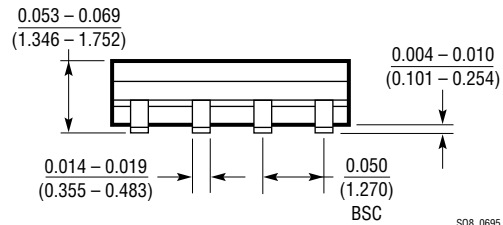
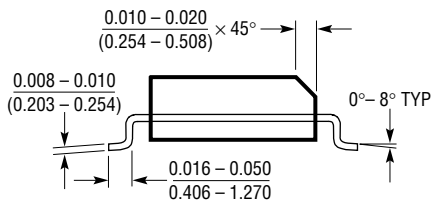
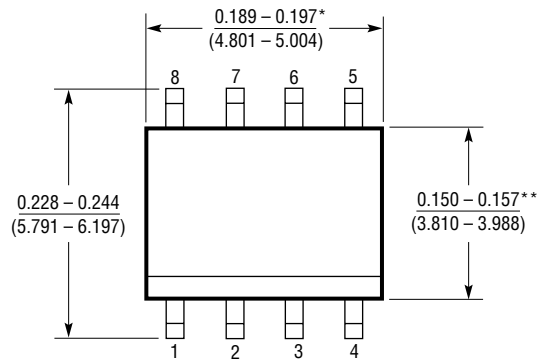

*DIMENSION DOES NOT INCLUDE MOLD FLASH. MOLD FLASH SHALL NOT EXCEED 0.006" (0.152mm) PER SIDE

**DIMENSION DOES NOT INCLUDE INTERLEAD FLASH. INTERLEAD FLASH SHALL NOT EXCEED 0.010" (0.254mm) PER SIDE

S08 0695

TYPICAL APPLICATIONS

LTC1400 Interface to TMS320C50

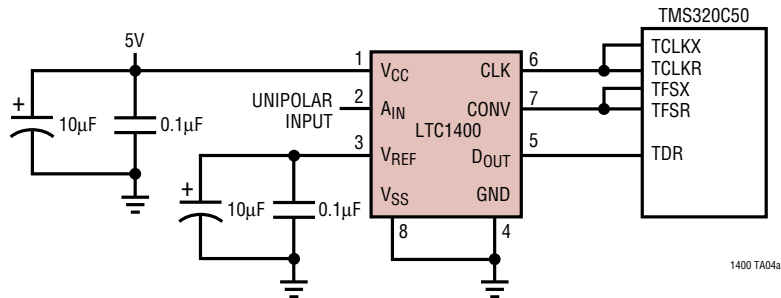

LTC1400 Interface to ADSP2181

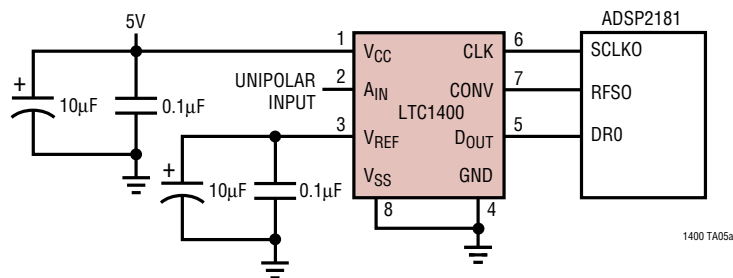

RELATED PARTS

PART NUMBER	DESCRIPTION	COMMENTS
LTC1285/LTC1288	12-Bit, 3V, 7.5/6.6ksps, Micropower Serial ADCs	0.48mW, 1 or 2 Channel Input, SO-8
LTC1286/LTC1298	12-Bit, 5V 12.5/11.16ksps, Micropower Serial ADCs	1.25mW, 1 or 2 Channel Input, SO-8
LTC1290	12-Bit, 50ksps 8-Channel Serial ADC	5V or ± 5V Input Range, 30mW, Full-duplex
LTC1296	12-Bit, 46.5ksps 8-Channel Serial ADC	5V or ± 5V Input Range, 30mW, Half-duplex
LTC1403/LTC1403A	12-/14-Bit, 2.8Msps Serial ADCs	3V, 15mW, MSOP Package
LTC1407/LTC1407A	12-/14-Bit, 3Msps Simultaneous Sampling ADCs	3V, 14mW, 2-Channel Differential Inputs, MSOP Package
LTC1417	14-Bit, 400ksps Serial ADC	5V or ± 5V, 20mW, Internal Reference, SSOP-16
LTC1609	16-Bit, 200ksps Serial ADC	5V, Configurable Bipolar or Unipolar Inputs to ±10V
LTC1860L/LTC1861L	12-Bit, 3V, 150ksps Serial ADCs	1.22mW, 1-/2-Channel Inputs, MSOP and SO-8
LTC1860/LTC1861	12-Bit, 5V, 250ksps Serial ADCs	4.25mW, 1-/2-Channel Inputs, MSOP and SO-8
LTC1864L/LTC1864L	16-Bit, 3V, 150KSPS Serial ADCs	1.22mW, 1-/2-Channel Inputs, MSOP and SO-8
LTC1864/LTC1864	16-Bit, 5V, 250ksps Serial ADCs	4.25mW, 1-/2-Channel Inputs, MSOP and SO-8

Looking for pricing, stock, or lifecycle information?

Click below to explore more details on WIN SOURCE:

 [View LTC1400CS8#PBF on WIN SOURCE](#)

 [Linear Technology](#) Information

Optimize Your Supply Chain with WIN SOURCE Solutions

-  Global Sourcing Solution
-  Obsolete Management
-  Cost Control Management
-  Shortage Management
-  Alternative Solution
-  Excess Inventory Management