



**THE DATASHEET OF
LTC1417CGN#PBF**



Low Power 14-Bit, 400ksps Sampling ADC Converter with Serial I/O

FEATURES

- 16-Pin Narrow SSOP Package (SO-8 Footprint)
- **Sample Rate: 400ksps**
- **$\pm 1.25\text{LSB INL}$ and $\pm 1\text{LSB DNL Max}$**
- **Power Dissipation: 20mW (Typ)**
- **Single Supply 5V or $\pm 5\text{V}$ Operation**
- **Serial Data Output**
- No Missing Codes Over Temperature
- Power Shutdown: Nap and Sleep
- External or Internal Reference
- Differential High Impedance Analog Input
- Input Range: 0V to 4.096V or $\pm 2.048\text{V}$
- 81dB S/(N + D) and -95dB THD at Nyquist

APPLICATIONS

- High Speed Data Acquisition
- Digital Signal Processing
- Isolated Data Acquisition Systems
- Audio and Telecom Processing
- Spectrum Instrumentation

DESCRIPTION

The LTC[®]1417 is a low power, 400ksps, 14-bit A/D converter. This versatile device can operate from a single 5V or $\pm 5\text{V}$ supplies. An onboard high performance sample-and-hold, a precision reference and internal trimming minimize external circuitry requirements. The low 20mW power dissipation is made even more attractive with two user-selectable power shutdown modes.

The LTC1417 converts 0V to 4.096V unipolar inputs when using a 5V supply and $\pm 2.048\text{V}$ bipolar inputs when using $\pm 5\text{V}$ supplies. DC specs include $\pm 1.25\text{LSB INL}$, $\pm 1\text{LSB DNL}$ and no missing codes over temperature. Outstanding AC performance includes 81dB S/(N + D) and -95dB THD at a Nyquist input frequency of 200kHz.

The internal clock is trimmed for 2 μs maximum conversion time. A separate convert start input and a data ready signal (BUSY) ease connections to FIFOs, DSPs and microprocessors.

 LTC and LT are registered trademarks of Linear Technology Corporation.

EQUIVALENT BLOCK DIAGRAM

A 400kHz, 14-Bit Sampling A/D Converter in a Narrow 16-Lead SSOP Package

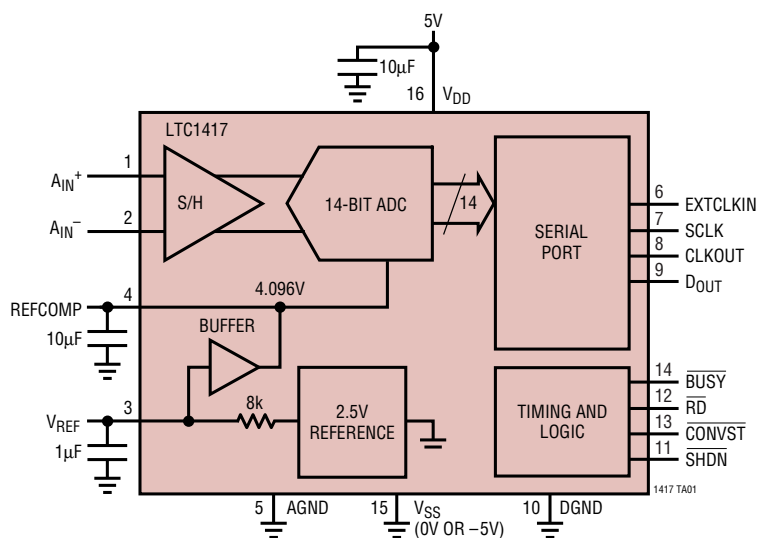

Effective Bits and Signal-to-(Noise + Distortion) vs Input Frequency

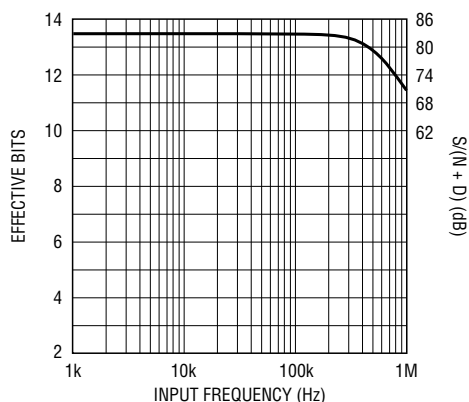

sn1417 1417fas

ABSOLUTE MAXIMUM RATINGS

(Notes 1, 2)

Positive Supply Voltage (V_{DD})	6V
Negative Supply Voltage (V_{SS})	
Bipolar Operation Only	-6V to GND
Total Supply Voltage (V_{DD} to V_{SS})	
Bipolar Operation Only	12V
Analog Input Voltage (Note 3)	
Unipolar Operation	-0.3V to ($V_{DD} + 0.3V$)
Bipolar Operation	($V_{SS} - 0.3$) to ($V_{DD} + 0.3V$)
Digital Input Voltage (Note 4)	
Unipolar Operation	-0.3V to 10V
Bipolar Operation	($V_{SS} - 0.3V$) to 10V
Digital Output Voltage	
Unipolar Operation	-0.3 to ($V_{DD} + 0.3V$)
Bipolar Operation	($V_{SS} - 0.3V$) to ($V_{DD} + 0.3V$)
Power Dissipation	500mW
Operating Temperature Range	
LTC1417AC/LTC1417C	0°C to 70°C
LTC1417AI/LTC1417I	-40°C to 85°C
Storage Temperature Range	-65°C to 150°C
Lead Temperature (Soldering, 10 sec)	300°C

PACKAGE/ORDER INFORMATION

<p>TOP VIEW</p> <p>GN PACKAGE 16-LEAD (NARROW) PLASTIC SSOP $T_{JMAX} = 110^{\circ}C$, $\theta_{JA} = 95^{\circ}C/W$</p>	ORDER PART NUMBER
	<p>LTC1417ACGN LTC1417CGN LTC1417AIGN LTC1417IGN</p>
	GN PART MARKING
	<p>1417A 1417 1417AI 1417I</p>

Consult LTC Marketing for parts specified with wider operating temperature ranges.

CONVERTER CHARACTERISTICS

The ● indicates specifications which apply over the full operating temperature range, otherwise specifications are at $T_A = 25^{\circ}C$. Specifications are measured while using the internal reference unless otherwise noted. (Notes 5, 6)

PARAMETER	CONDITIONS	LTC1417			LTC1417A			UNITS
		MIN	TYP	MAX	MIN	TYP	MAX	
Resolution		●	14		14			Bits
No Missing Codes		●	13		14			Bits
Integral Linearity Error	(Note 7)	●	±0.8	±2	±0.5	±1.25		LSB
Differential Linearity Error		●	±0.7	±1.5	±0.35	±1		LSB
Transition Noise	(Note 12)		0.33		0.33			LSB _{RMS}
Offset Error	External Reference (Note 8)	●	±5	±20	±2	±10		LSB
Full-Scale Error	Internal Reference		±15	±60	±15	±60		LSB
	External Reference = 2.5V		±5	±30	±5	±15		LSB
Full-Scale Tempco	$I_{OUT(REF)} = 0$, Internal Reference, $0^{\circ}C \leq T_A \leq 70^{\circ}C$		±15		±10			ppm/°C
	$I_{OUT(REF)} = 0$, Internal Reference, $-40^{\circ}C \leq T_A \leq 85^{\circ}C$				±20			ppm/°C
	$I_{OUT(REF)} = 0$, External Reference				±1			ppm/°C

ANALOG INPUT

The ● indicates specifications which apply over the full operating temperature range, otherwise specifications are at $T_A = 25^{\circ}C$. (Note 5)

SYMBOL	PARAMETER	CONDITIONS	MIN	TYP	MAX	UNITS
V_{IN}	Analog Input Range (Note 9)	$4.75V \leq V_{DD} \leq 5.25V$ (Unipolar)	●	0 to 4.096		V
		$4.75V \leq V_{DD} \leq 5.25V$, $-5.25V \leq V_{SS} \leq -4.75V$ (Bipolar)	●	±2.048		V
I_{IN}	Analog Input Leakage Current	CONVST = High	●		±1	μA

sn1417 1417ias

ANALOG INPUT

The ● indicates specifications which apply over the full operating temperature range, otherwise specifications are at $T_A = 25^\circ\text{C}$. (Note 5)

SYMBOL	PARAMETER	CONDITIONS	MIN	TYP	MAX	UNITS
C_{IN}	Analog Input Capacitance	Between Conversions (Sample Mode) During Conversions (Hold Mode)		14 3		pF pF
t_{ACQ}	Sample-and-Hold Acquisition Time		●	150	500	ns
t_{AP}	Sample-and-Hold Aperture Time			-1.5		ns
t_{jitter}	Sample-and-Hold Aperture Time Jitter			5		pSRMS
CMRR	Analog Input Common Mode Rejection Ratio	$0V < (A_{IN}^+ = A_{IN}^-) < 4.096V$ (Unipolar) $-2.048V < (A_{IN}^+ = A_{IN}^-) < 2.048V$ (Bipolar)		65 65		dB dB

DYNAMIC ACCURACY

The ● indicates specifications which apply over the full operating temperature range, otherwise specifications are at $T_A = 25^\circ\text{C}$. (Note 5)

SYMBOL	PARAMETER	CONDITIONS	MIN	TYP	MAX	UNITS
S/(N + D)	Signal-to-(Noise + Distortion) Ratio	100kHz Input Signal	79	81		dB
THD	Total Harmonic Distortion	100kHz Input Signal, First Five Harmonics	-85	-95		dB
SFDR	Spurious Free Dynamic Range	200kHz Input Signal		-98		dB
IMD	Intermodulation Distortion	$f_{IN1} = 97.3\text{kHz}$, $f_{IN2} = 104.6\text{kHz}$		-97		dB
	Full Power Bandwidth			10		MHz
	Full Linear Bandwidth	$S/(N + D) \geq 77\text{dB}$		0.8		MHz

INTERNAL REFERENCE CHARACTERISTICS

The ● indicates specifications which apply over the full operating temperature range, otherwise specifications are at $T_A = 25^\circ\text{C}$. (Note 5)

PARAMETER	CONDITIONS	MIN	TYP	MAX	UNITS	
V_{REF} Output Voltage	$I_{OUT} = 0$	●	2.480	2.500	2.520	V
V_{REF} Output Tempco	$I_{OUT} = 0$, $0^\circ\text{C} \leq T_A \leq 70^\circ\text{C}$ $I_{OUT} = 0$, $-40^\circ\text{C} \leq T_A \leq 85^\circ\text{C}$			± 10 ± 20	ppm/ $^\circ\text{C}$ ppm/ $^\circ\text{C}$	
V_{REF} Line Regulation	$4.75V \leq V_{DD} \leq 5.25V$ $-5.25V \leq V_{SS} \leq -4.75V$			0.05 0.05	LSB/V LSB/V	
V_{REF} Output Resistance	$0.1\text{mA} \leq I_{OUT} \leq 0.1\text{mA}$			8	$k\Omega$	

DIGITAL INPUTS AND DIGITAL OUTPUTS

The ● indicates specifications which apply over the full operating temperature range, otherwise specifications are at $T_A = 25^\circ\text{C}$. (Note 5)

SYMBOL	PARAMETER	CONDITIONS	MIN	TYP	MAX	UNITS
V_{IH}	High Level Input Voltage	$V_{DD} = 5.25V$	●	2.4		V
V_{IL}	Low Level Input Voltage	$V_{DD} = 4.75V$	●		0.8	V
I_{IN}	Digital Input Current	$V_{IN} = 0V$ to V_{DD}	●		± 10	μA
C_{IN}	Digital Input Capacitance			1.4		pF
V_{OH}	High Level Output Voltage	$V_{DD} = 4.75V$, $I_O = -10\mu\text{A}$ $V_{DD} = 4.75V$, $I_O = -200\mu\text{A}$	●	4.0	4.74	V V
V_{OL}	Low Level Output Voltage	$V_{DD} = 4.75V$, $I_O = 160\mu\text{A}$ $V_{DD} = 4.75V$, $I_O = -1.6\text{mA}$	●		0.05 0.10	V V
I_{OZ}	High-Z Output Leakage D_{OUT} , CLK_{OUT}	$V_{OUT} = 0V$ to V_{DD} , \overline{RD} High	●		± 10	μA
C_{OZ}	High-Z Output Capacitance D_{OUT} , CLK_{OUT}	\overline{RD} High (Note 9)	●		15	pF
I_{SOURCE}	Output Source Current	$V_{OUT} = 0V$		-10		mA
I_{SINK}	Output Sink Current	$V_{OUT} = V_{DD}$		10		mA

POWER REQUIREMENTS

The ● indicates specifications which apply over the full operating temperature range, otherwise specifications are at $T_A = 25^\circ\text{C}$. (Note 5)

SYMBOL	PARAMETER	CONDITIONS	MIN	TYP	MAX	UNITS
V_{DD}	Positive Supply Voltage (Notes 10, 11)		4.75		5.25	V
V_{SS}	Negative Supply Voltage (Note 10)	Bipolar Only ($V_{SS} = 0\text{V}$ for Unipolar)	-4.75		-5.25	V
I_{DD}	Positive Supply Current	Unipolar, \overline{RD} High (Note 5)	●	4.0	5.5	mA
		Bipolar, \overline{RD} High (Note 5)	●	4.3	6.0	mA
	Nap Mode Sleep Mode	$\overline{SHDN} = 0\text{V}$, $\overline{RD} = 0\text{V}$ $\overline{SHDN} = 0\text{V}$, $\overline{RD} = 5\text{V}$		750 0.1		μA μA
I_{SS}	Negative Supply Current	Bipolar, \overline{RD} High (Note 5)	●	2.0	2.8	mA
	Nap Mode	$\overline{SHDN} = 0\text{V}$, $\overline{RD} = 0\text{V}$		0.7		μA
	Sleep Mode	$\overline{SHDN} = 0\text{V}$, $\overline{RD} = 5\text{V}$		1.5		nA
P_{DIS}	Power Dissipation	Unipolar	●	20.0	27.5	mW
		Bipolar	●	31.5	44	mW

TIMING CHARACTERISTICS

The ● indicates specifications which apply over the full operating temperature range, otherwise specifications are at $T_A = 25^\circ\text{C}$. (Note 5)

SYMBOL	PARAMETER	CONDITIONS	MIN	TYP	MAX	UNITS
$f_{\text{SAMPLE}(\text{MAX})}$	Maximum Sampling Frequency		●	400		kHz
t_{CONV}	Conversion Time		●	1.8	2.25	μs
t_{ACQ}	Acquisition Time		●	150	500	ns
$t_{\text{ACQ}} + t_{\text{CONV}}$	Acquisition Plus Conversion Time		●	2.1	2.5	μs
t_1	$\overline{SHDN} \uparrow$ to $\overline{\text{CONVST}} \downarrow$ Wake-Up Time from Nap Mode	(Note 10)		500		ns
t_2	$\overline{\text{CONVST}}$ Low Time	(Notes 10, 11)	●	40		ns
t_3	$\overline{\text{CONVST}}$ to $\overline{\text{BUSY}}$ Delay	$C_L = 25\text{pF}$	●	35	70	ns
t_4	Data Ready Before $\overline{\text{BUSY}} \uparrow$	$C_L = 25\text{pF}$	●	7	12	ns
t_5	Delay Between Conversions	(Note 10)	●	250		ns
t_6	Wait Time $\overline{RD} \downarrow$ After $\overline{\text{BUSY}} \uparrow$		●	-5		ns
t_7	Data Access Time After $\overline{RD} \downarrow$	$C_L = 25\text{pF}$	●	15	30	ns
					40	ns
		$C_L = 100\text{pF}$	●	20	40	ns
					55	ns
t_8	Bus Relinquish Time		●		35	ns
t_9	\overline{RD} Low Time		●	t_7		ns
t_{10}	$\overline{\text{CONVST}}$ High Time		●	40		ns
t_{11}	Delay Time, $\text{SCLK} \downarrow$ to D_{OUT} Valid	$C_L = 25\text{pF}$	●	15	40	ns
t_{12}	Time from Previous Data Remain Valid After $\text{SCLK} \downarrow$	$C_L = 25\text{pF}$	●	5	10	ns
f_{SCLK}	Shift Clock Frequency	(Note 13)	●	0	20	MHz
f_{EXTCLKIN}	External Conversion Clock Frequency		●	0.05	9	MHz
$t_{\text{dEXTCLKIN}}$	Delay Time, $\overline{\text{CONVST}} \downarrow$ to External Conversion Clock Input	(Note 9)	●		20	μs

TIMING CHARACTERISTICS The ● indicates specifications which apply over the full operating temperature range, otherwise specifications are at $T_A = 25^\circ\text{C}$. (Note 5)

SYMBOL	PARAMETER	CONDITIONS	MIN	TYP	MAX	UNITS
$t_{H\ SCLK}$	SCLK High Time	(Note 9)	● 10			ns
$t_{L\ SCLK}$	SCLK Low Time	(Note 9)	● 10			ns
$t_{H\ EXTCLKIN}$	EXTCLKIN High Time		● 0.04		20	μs
$t_{L\ EXTCLKIN}$	EXTCLKIN Low Time		● 0.04		20	μs
f_{CLKOUT}	Conversion Clock Output Frequency	Internal Conversion Clock Mode (EXTCLKIN = 5V)		9.4		MHz
		External Conversion Clock Mode (EXTCLKIN is Driven by an External Conversion Clock Input)		$f_{EXTCLKIN}$		MHz

Note 1: Absolute Maximum Ratings are those values beyond which the life of a device may be impaired.

Note 2: All voltage values are with respect to ground with DGND and AGND wired together (unless otherwise noted).

Note 3: When these pin voltages are taken below V_{SS} or above V_{DD} , they will be clamped by internal diodes. This product can handle input currents greater than 100mA without latchup if the pin is driven below V_{SS} (ground for unipolar mode) or above V_{DD} .

Note 4: When these pin voltages are taken below V_{SS} they will be clamped by internal diodes. This product can handle input currents greater than 100mA below V_{SS} without latchup. These pins are not clamped to V_{DD} .

Note 5: $V_{DD} = 5\text{V}$, $V_{SS} = -5\text{V}$, $f_{SAMPLE} = 400\text{kHz}$, $t_r = t_f = 5\text{ns}$ unless otherwise specified.

Note 6: Linearity, offset and full-scale specifications apply for a single-ended A_{IN}^+ input with A_{IN}^- grounded.

Note 7: Integral nonlinearity is defined as the deviation of a code from a straight line passing through the actual endpoints of the transfer curve. The deviation is measured from the center of the quantization band.

Note 8: Bipolar offset is the offset voltage measured from -0.5LSB when the output code flickers between 0000 0000 0000 00 and 1111 1111 1111 11.

Note 9: Guaranteed by design, not subject to test.

Note 10: Recommended operating conditions.

Note 11: The falling $\overline{\text{CONVST}}$ edge starts a conversion. If $\overline{\text{CONVST}}$ returns high at a critical point during the conversion it can create small errors. For best results ensure that $\overline{\text{CONVST}}$ returns high either within 625ns after conversion start or after $\overline{\text{BUSY}}$ rises.

Note 12: Typical RMS noise at the code transitions. See Figure 2 for histogram.

Note 13: t_{11} of 40ns maximum allows f_{SCLK} up to 10MHz for rising capture with 50% duty cycle. f_{SCLK} up to 20MHz for falling capture with 5ns setup time.

TYPICAL PERFORMANCE CHARACTERISTICS ($T_A = 25^\circ\text{C}$, unless otherwise specified)

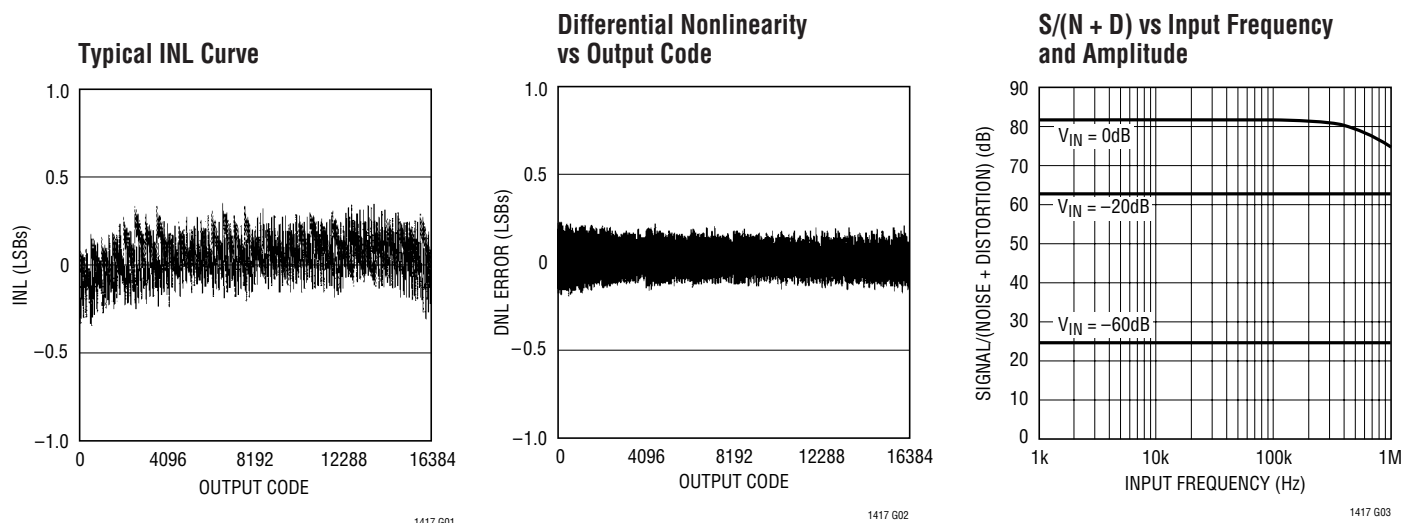

TYPICAL PERFORMANCE CHARACTERISTICS ($T_A = 25^\circ\text{C}$, unless otherwise specified)

Signal-to-Noise Ratio vs Input Frequency

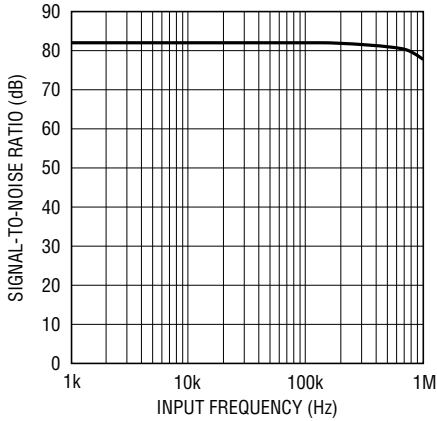

1417 G04

Distortion vs Input Frequency

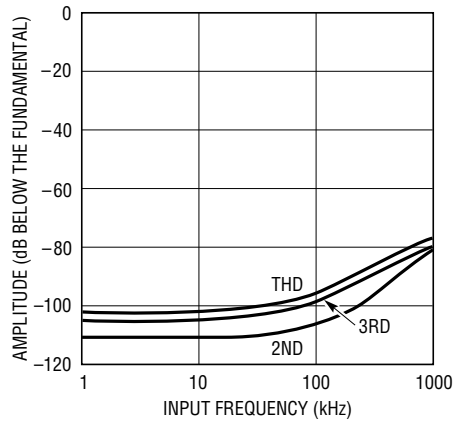

1417 G05

Spurious-Free Dynamic Range vs Input Frequency

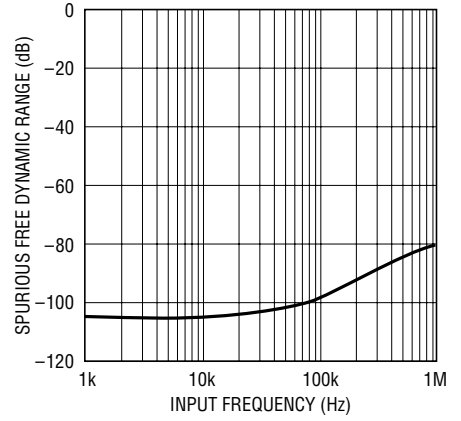

1417 G06

Nonaveraged, 4096 Point FFT, Input Frequency = 10kHz

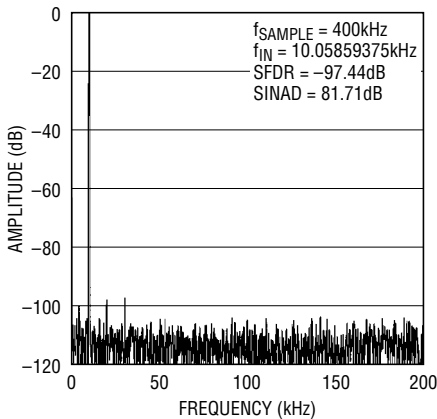

1417 G07

Nonaveraged, 4096 Point FFT, Input Frequency = 200kHz

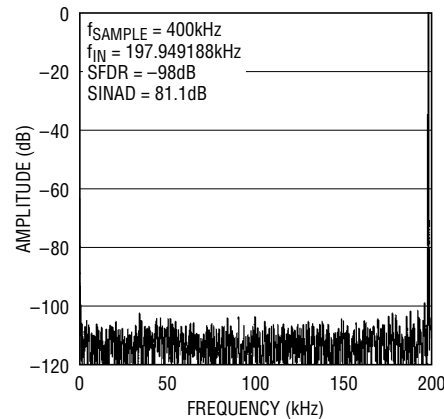

1417 G08

Intermodulation Distortion Plot

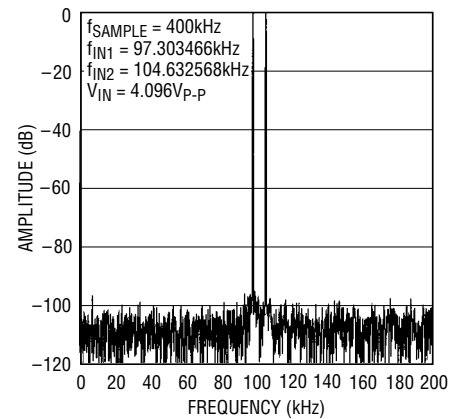

1417 G09

Power Supply Feedthrough vs Ripple Frequency

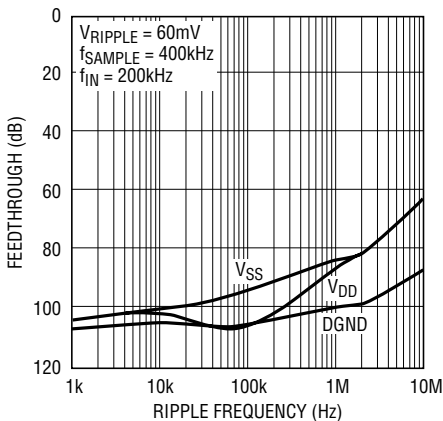

1417 G10

Input Common Mode Rejection vs Input Frequency

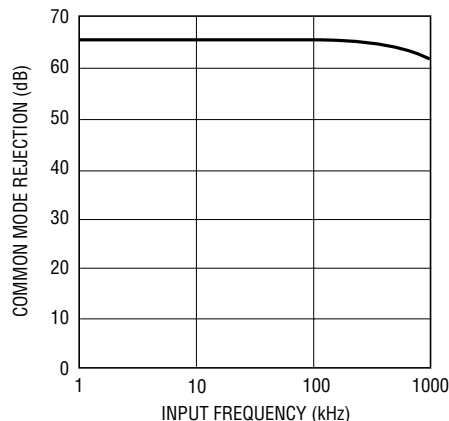

1417 G11

Input Offset Voltage Shift vs Source Resistance

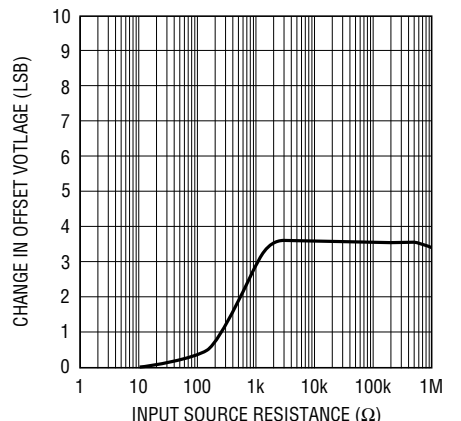

1417 G12

TYPICAL PERFORMANCE CHARACTERISTICS ($T_A = 25^\circ\text{C}$, unless otherwise specified)

V_{DD} Supply Current vs Temperature (Unipolar Mode)

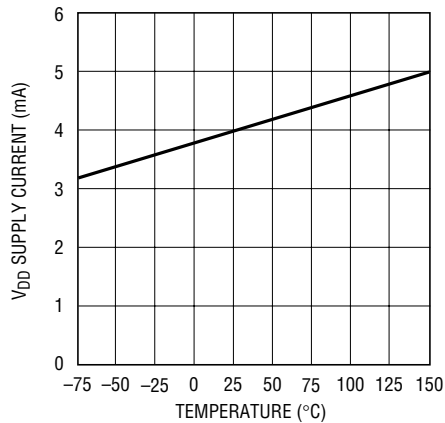

1417 G13

V_{DD} Supply Current vs Temperature (Bipolar Mode)

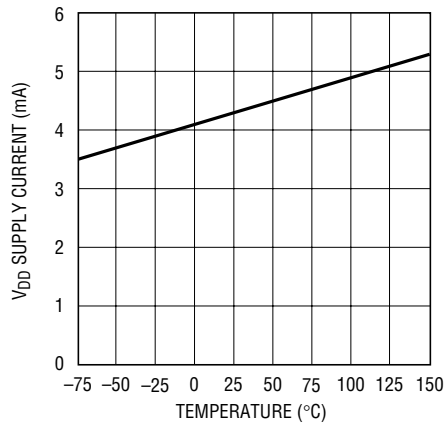

1417 G14

V_{SS} Supply Current vs Temperature (Bipolar Mode)

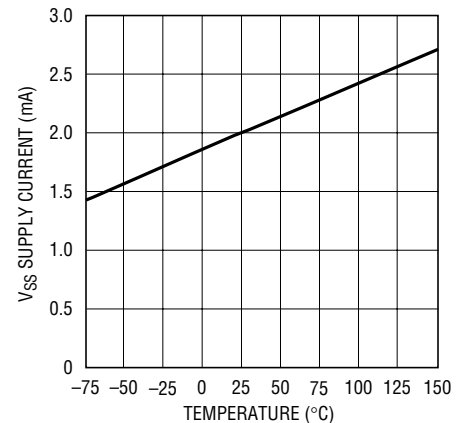

1417 G15

V_{DD} Supply Current vs Sampling Frequency (Unipolar Mode)

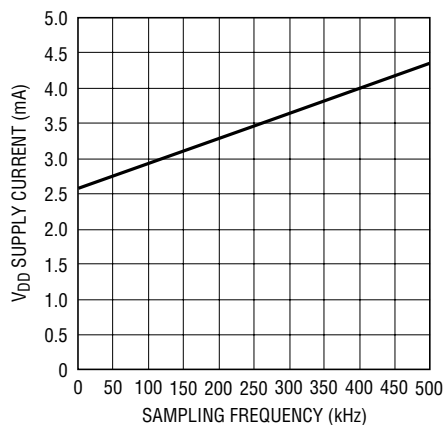

1417 G16

V_{DD} Supply Current vs Sampling Frequency (Bipolar Mode)

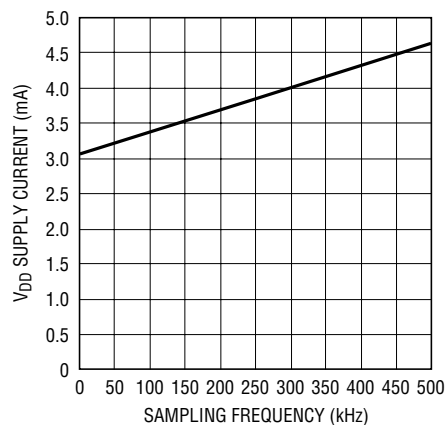

1417 G17

V_{SS} Supply Current vs Sampling Frequency (Bipolar Mode)

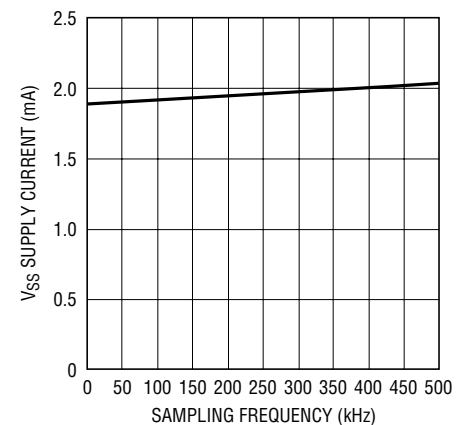

1417 G18

PIN FUNCTIONS

A_{IN}^+ (Pin 1): Positive Analog Input.

A_{IN}^- (Pin 2): Negative Analog Input.

V_{REF} (Pin 3): 2.50V Reference Output. Bypass to AGND with 1 μ F.

REFCOMP (Pin 4): 4.096V Reference Output. Bypass to AGND using 10 μ F tantalum in parallel with 0.1 μ F ceramic.

AGND (Pin 5): Analog Ground.

EXTCLKIN (Pin 6): External Conversion Clock Input. A 5V input will enable the internal conversion clock.

SCLK (Pin 7): Data Clock Input.

CLKOUT (Pin 8): Conversion Clock Output.

D_{OUT} (Pin 9): Serial Data Output.

DGND (Pin 10): Digital Ground.

SHDN (Pin 11): Power Shutdown Input. Low selects shutdown. Shutdown mode selected by \overline{RD} . $\overline{RD} = 0V$ for Nap mode and $\overline{RD} = 5V$ for Sleep mode.

\overline{RD} (Pin 12): Read Input. This enables the output drivers. \overline{RD} also sets the shutdown mode when SHDN goes low. \overline{RD} and SHDN low selects the quick wake-up Nap mode, \overline{RD} high and SHDN low selects Sleep mode.

sn1417 1417fas

PIN FUNCTIONS

CONVST (Pin 13): Conversion Start Signal. This active low signal starts a conversion on its falling edge.

BUSY (Pin 14): The $\overline{\text{BUSY}}$ output shows the converter status. It is low when a conversion is in progress.

V_{SS} (Pin 15): Negative Supply, -5V for Bipolar Operation. Bypass to AGND using $10\mu\text{F}$ tantalum in parallel with $0.1\mu\text{F}$ ceramic. Analog ground for unipolar operation.

V_{DD} (Pin 16): 5V Positive Supply. Bypass to AGND with $10\mu\text{F}$ tantalum in parallel with $0.1\mu\text{F}$ ceramic.

TEST CIRCUITS

Load Circuits for Access Timing

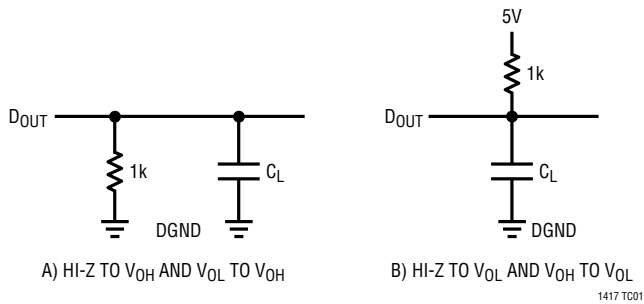

Load Circuits for Output Float Delay

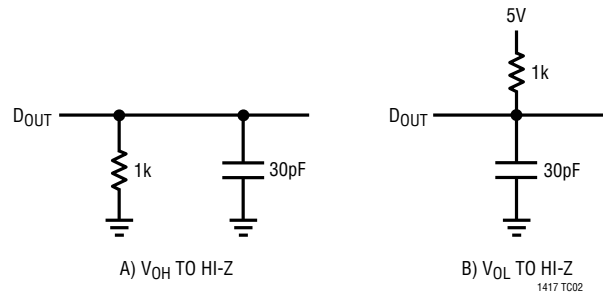

FUNCTIONAL BLOCK DIAGRAM

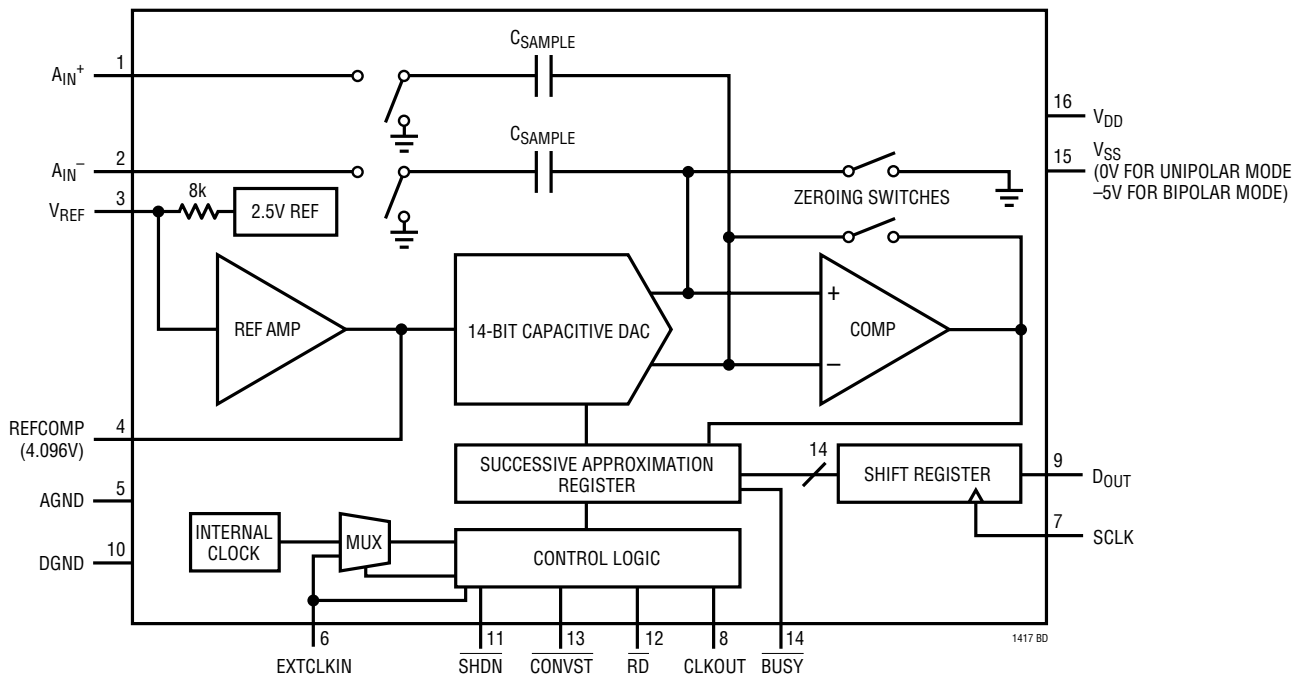

APPLICATIONS INFORMATION

CONVERSION DETAILS

The LTC1417 uses a successive approximation algorithm and an internal sample-and-hold circuit to convert an analog signal to a 14-bit serial output. The ADC is complete with a precision reference and an internal clock. The control logic provides easy interface to microprocessors and DSPs (please refer to Digital Interface section for the data format).

Conversion start is controlled by the $\overline{\text{CONVST}}$ input. At the start of the conversion, the successive approximation register (SAR) is reset. Once a conversion cycle has begun, it cannot be restarted.

During the conversion, the internal differential 14-bit capacitive DAC output is sequenced by the SAR from the most significant bit (MSB) to the least significant bit (LSB). Referring to Figure 1, the A_{IN}^+ and A_{IN}^- inputs are connected to the sample-and-hold capacitors (C_{SAMPLE}) during the acquire phase and the comparator offset is nulled by the zeroing switches. In this acquire phase, a minimum delay of 500ns will provide enough time for the sample-and-hold capacitors to acquire the analog signal. During the convert phase, the comparator zeroing switches open, placing the comparator in compare mode. The input switches connect the C_{SAMPLE} capacitors to ground, transferring the differential analog input charge onto the

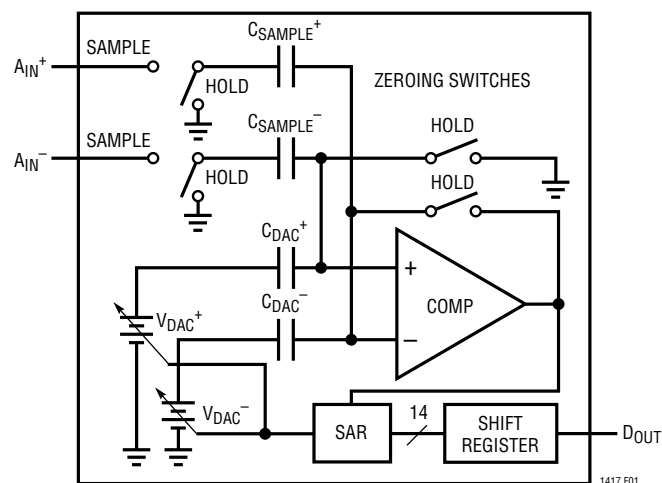

Figure 1. Simplified Block Diagram

summing junction. This input charge is successively compared with the binary weighted charges supplied by the differential capacitive DAC. Bit decisions are made by the high speed comparator. At the end of a conversion, the differential DAC output balances the A_{IN}^+ and A_{IN}^- input charges. The SAR contents (a 14-bit data word) that represent the difference of A_{IN}^+ and A_{IN}^- are output through the serial pin D_{OUT} .

DC Performance

One way of measuring the transition noise associated with a high resolution ADC is to use a technique where a DC signal is applied to the input of the ADC and the resulting output codes are collected over a large number of conversions. For example in Figure 2, the distribution of output code is shown for a DC input that has been digitized 4096 times. The distribution is Gaussian and the RMS code transition is about 0.33LSB.

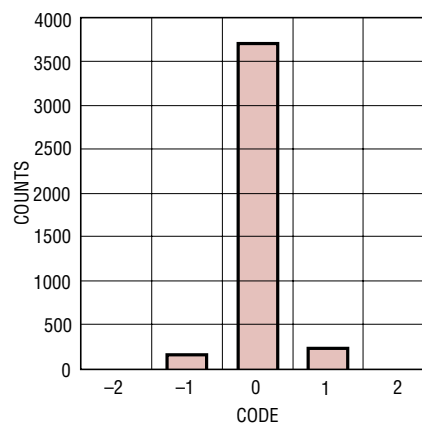

Figure 2. Histogram for 4096 Conversions

DYNAMIC PERFORMANCE

The LTC1417 has excellent high speed sampling capability. FFT (Fast Fourier Transform) test techniques are used to test the ADC's frequency response, distortion and noise performance at the rated throughput. By applying a low distortion sine wave and analyzing the digital output using an FFT algorithm, the ADC's spectral content can be examined for frequencies beyond the fundamental. Figure 3 shows a typical LTC1417 FFT plot.

APPLICATIONS INFORMATION

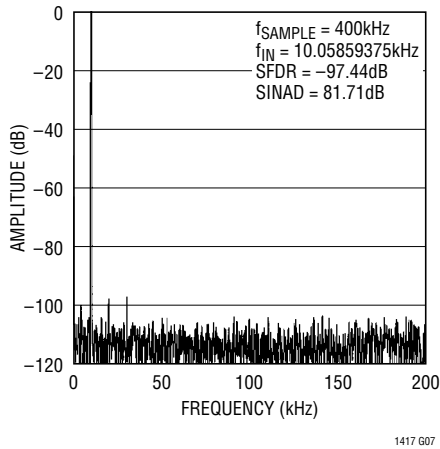

Figure 3a. LTC1417 Nonaveraged, 4096 Point FFT, Input Frequency = 10kHz

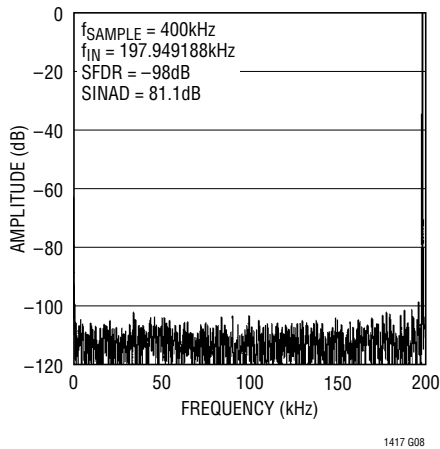

Figure 3b. LTC1417 Nonaveraged, 4096 Point FFT, Input Frequency = 200kHz

Signal-to-Noise Ratio

The signal-to-noise plus distortion ratio $[S/(N + D)]$ is the ratio between the RMS amplitude of the fundamental input frequency to the RMS amplitude of all other frequency components at the A/D output. The output is band limited to frequencies from above DC and below half the sampling frequency. Figure 3b shows a typical spectral content with a 400kHz sampling rate and a 200kHz input. The dynamic performance is excellent for input frequencies up to and beyond the Nyquist limit of 200kHz.

Effective Number of Bits

The effective number of bits (ENOBs) is a measurement of the resolution of an ADC and is directly related to the $S/(N + D)$ by the equation:

$$\text{ENOB (N)} = [S/(N + D) - 1.76]/6.02$$

where N is the effective number of bits of resolution and $S/(N + D)$ is expressed in dB. At the maximum sampling rate of 400kHz, the LTC1417 maintains near ideal ENOBs up to the Nyquist input frequency of 200kHz (refer to Figure 4).

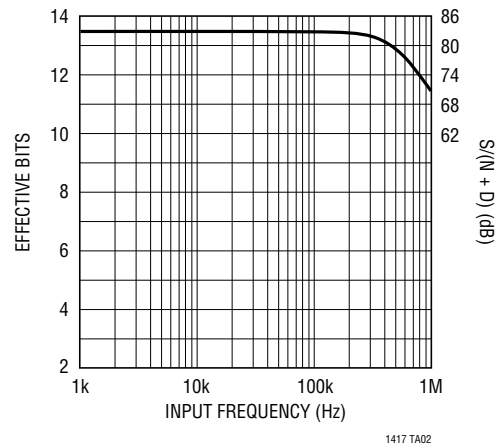

Figure 4. Effective Bits and Signal/(Noise + Distortion) vs Input Frequency

Total Harmonic Distortion

Total harmonic distortion (THD) is the ratio of the RMS sum of all harmonics of the input signal to the fundamental itself. The out-of-band harmonics alias into the frequency band between DC and half the sampling frequency. THD is expressed as:

$$\text{THD} = 20\text{Log} \frac{\sqrt{V_2^2 + V_3^2 + V_4^2 + \dots + V_n^2}}{V_1}$$

where V_1 is the RMS amplitude of the fundamental frequency and V_2 through V_n are the amplitudes of the second through nth harmonics. THD vs Input Frequency is shown in Figure 5. The LTC1417 has good distortion performance up to the Nyquist frequency and beyond.

APPLICATIONS INFORMATION

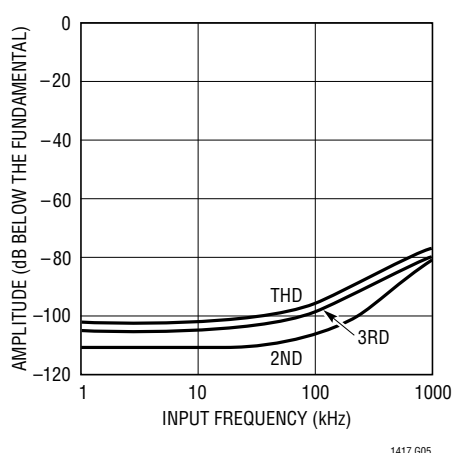

Figure 5. Distortion vs Input Frequency

Intermodulation Distortion

If the ADC input signal consists of more than one spectral component, the ADC transfer function nonlinearity can produce intermodulation distortion (IMD) in addition to THD. IMD is the change in one sinusoidal input caused by the presence of another sinusoidal input at a different frequency.

If two pure sine waves of frequencies f_a and f_b are applied to the ADC input, nonlinearities in the ADC transfer function can create distortion products at the sum and difference frequencies of $m f_a \pm n f_b$, where m and $n = 0, 1, 2, 3$, etc. For example, 2nd order IMD terms include $(f_a \pm f_b)$. If the two input sine waves are equal in magnitude, the value (in decibels) of the 2nd-order IMD products can be expressed by the following formula:

$$\text{IMD}(f_a + f_b) = 20 \text{Log} \frac{\text{Amplitude at } (f_a \pm f_b)}{\text{Amplitude at } f_a}$$

Peak Harmonic or Spurious Noise

The peak harmonic or spurious noise is the largest spectral component excluding the input signal and DC. This value is expressed in decibels relative to the RMS value of a full-scale input signal.

Full-Power and Full-Linear Bandwidth

The full-power bandwidth is the input frequency at which the amplitude of the reconstructed fundamental is reduced by 3dB from a full-scale input signal.

The full-linear bandwidth is the input frequency at which the $S/(N + D)$ has dropped to 77dB (12.5 effective bits). The LTC1417 has been designed to optimize input bandwidth, allowing the ADC to undersample input signals with frequencies above the converter's Nyquist Frequency. The noise floor stays very low at high frequencies; $S/(N + D)$ becomes dominated by distortion at frequencies far beyond Nyquist.

DRIVING THE ANALOG INPUT

The differential analog inputs of the LTC1417 are easy to drive. The inputs may be driven differentially or as a single-ended input (i.e., the A_{IN}^- input is grounded). The A_{IN}^+ and A_{IN}^- inputs are sampled at the same instant. Any unwanted signal that is common to both inputs will be reduced by the common mode rejection of the sample-and-hold circuit. The inputs draw only one small current spike while charging the sample-and-hold capacitors at the end of conversion. During conversion, the analog inputs draw only a small leakage current. If the source impedance of the driving circuit is low, then the LTC1417 inputs can be driven directly. As source impedance increases, so will acquisition time (see Figure 7). For minimum acquisition time, with high source impedance, a buffer amplifier must be used. The only requirement is that the amplifier driving the analog input(s) must settle after the small current spike before the next conversion starts — 500ns for full throughput rate.

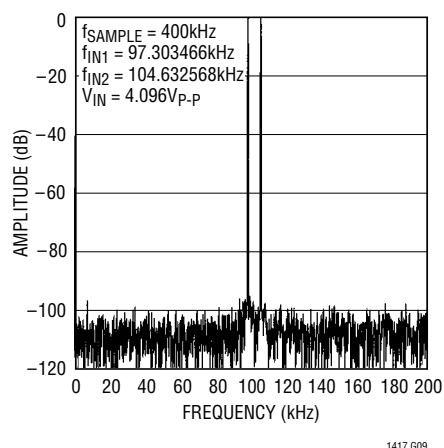
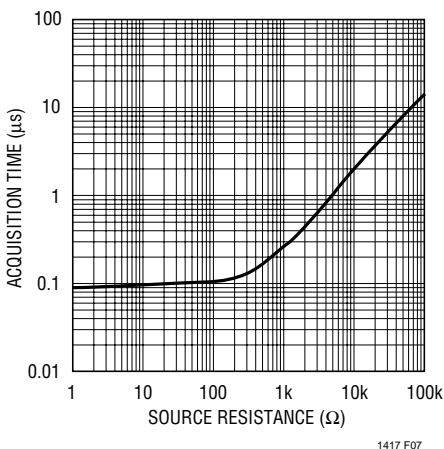

Figure 6. Intermodulation Distortion Plot

APPLICATIONS INFORMATION

Figure 7. t_{ACQ} vs Source Resistance

Choosing an Input Amplifier

Choosing an input amplifier is easy if a few requirements are taken into consideration. First, choose an amplifier that has a low output impedance ($<100\Omega$) at the closed-loop bandwidth frequency. For example, if an amplifier is used in a gain of 1 and has a closed-loop bandwidth of 10MHz, then the output impedance at 10MHz must be less than 100Ω . The second requirement is that the closed-loop bandwidth must be greater than 10MHz to ensure adequate small-signal settling for full throughput rate. If slower op amps are used, more settling time can be provided by increasing the time between conversions.

The best choice for an op amp to drive the LTC1417 will depend on the application. Generally, applications fall into two categories: AC applications where dynamic specifications are most critical and time domain applications where DC accuracy and settling time are most critical. The following list is a summary of the op amps that are suitable for driving the LTC1417. More detailed information is available in the Linear Technology Databooks and on the LinearView™ CD-ROM.

LT®1354: 12MHz, $400V/\mu s$ Op Amp. 1.25mA maximum supply current. Good AC and DC specifications. Suitable for dual supply application.

LT1357: 25MHz, $600V/\mu s$ Op Amp. 2.5mA maximum supply current. Good AC and DC specifications. Suitable for dual supply application.

LT1360: 50MHz Voltage Feedback Amplifier. 3.8mA supply current, $\pm 2.5V$ to $\pm 15V$ supplies. High A_{VOL} , 1mV offset and 80ns settling to 1mV (4V step, inverting and noninverting configurations) make it suitable for fast DC applications. Excellent AC specifications. Dual and quad versions are available as LT1361 and LT1362.

LT1468: 90MHz Voltage Feedback Amplifier. $\pm 5V$ to $\pm 15V$ supplies. Lower distortion and noise. Settles to 0.01% in 770ns. Distortion is $-115dB$ to 20kHz.

LT1498/LT1499: 10MHz, $6V/\mu s$, Dual/Quad Rail-to-Rail Input and Output Op Amps. 1.7mA supply current per amplifier. 2.2V to $\pm 15V$ supplies. Good AC performance, input noise voltage = $12nV/\sqrt{Hz}$ (typ).

LT1630/LT1631: 30MHz, $10V/\mu s$, Dual/Quad Rail-to-Rail Input and Output Precision Op Amps. 3.5mA supply current per amplifier. 2.7V to $\pm 15V$ supplies. Best AC performance, input noise voltage = $6nV/\sqrt{Hz}$ (typ), THD = $-86dB$ at 100kHz.

LT1813: Dual 100MHz $750V/\mu s$ 3mA VFA. 5V to $\pm 5V$ supplies. Distortion is $-86dB$ to 100kHz and $-77dB$ to 1MHz with $\pm 5V$ supplies ($2V_{p-p}$ into 500Ω). Great part for fast AC applications with $\pm 5V$ supplies.

Input Filtering

The noise and the distortion of the input amplifier and other circuitry must be considered since they will add to the LTC1417 noise and distortion. The small-signal bandwidth of the sample-and-hold circuit is 10MHz. Any noise or distortion products that are present at the analog inputs will be summed over this entire bandwidth. Noisy input circuitry should be filtered prior to the analog inputs to minimize noise. A simple 1-pole RC filter is sufficient for many applications. For example, Figure 8 shows a 1000pF

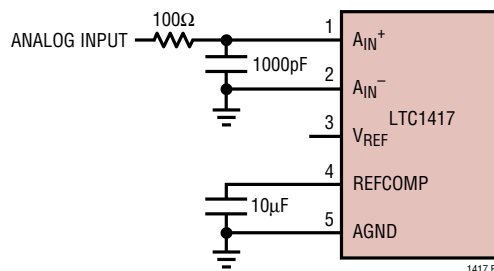

Figure 8. RC Input Filter

APPLICATIONS INFORMATION

capacitor from $+A_{IN}$ to ground and a 100Ω source resistor to limit the input bandwidth to 1.6MHz . The 1000pF capacitor also acts as a charge reservoir for the input sample-and-hold and isolates the ADC input from sampling glitch sensitive circuitry. High quality capacitors and resistors should be used since these components can add distortion. NPO and silver mica type dielectric capacitors have excellent linearity. Carbon surface mount resistors can also generate distortion from self heating and from damage that may occur during soldering. Metal film surface mount resistors are much less susceptible to both problems.

Input Range

The $\pm 2.048\text{V}$ and 0V to 4.096V input ranges of the LTC1417 are optimized for low noise and low distortion. Most op amps also perform well over these ranges, allowing direct coupling to the analog inputs and eliminating the need for special translation circuitry.

Some applications may require other input ranges. The LTC1417 differential inputs and reference circuitry can accommodate other input ranges often with little or no additional circuitry. The following sections describe the reference and input circuitry and how they affect the input range.

INTERNAL REFERENCE

The LTC1417 has an on-chip, temperature compensated, curvature corrected, bandgap reference which is factory trimmed to 2.500V . It is internally connected to a reference amplifier and is available at Pin 3. An $8\text{k}\Omega$ resistor is in series with the output so that it can be easily overdriven in applications where an external reference is required, see Figure 9. A capacitor must be connected between the

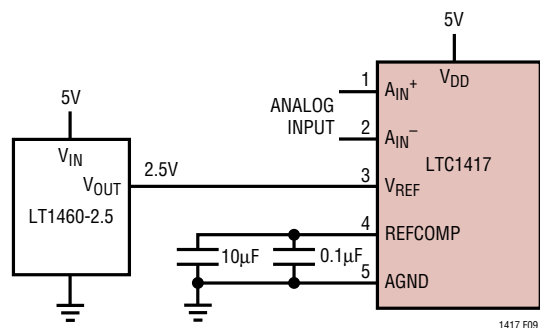

Figure 9. Using the LT1460 as an External Reference

reference amplifier compensation pin (REFCOMP, Pin 4) and ground. The reference is stable with capacitors of $1\mu\text{F}$ or greater. For the best noise performance, a $10\mu\text{F}$ in parallel with a $0.1\mu\text{F}$ ceramic is recommended.

The V_{REF} pin can be driven with a DAC or other means to provide input span adjustment. The reference should be kept in the range of 2.25V to 2.75V for specified linearity.

UNIPOLAR / BIPOLAR OPERATION AND ADJUSTMENT

Figure 10a shows the input/output characteristics for the LTC1417. The code transitions occur midway between successive integer LSB values (i.e., 0.5LSB , 1.5LSB , 2.5LSB , ... $\text{FS} - 1.5\text{LSB}$). The output code is natural binary with $1\text{LSB} = \text{FS}/16384 = 4.096\text{V}/16384 = 250\mu\text{V}$. Figure 10b shows the input/output transfer characteristics for the bipolar mode in two's complement format.

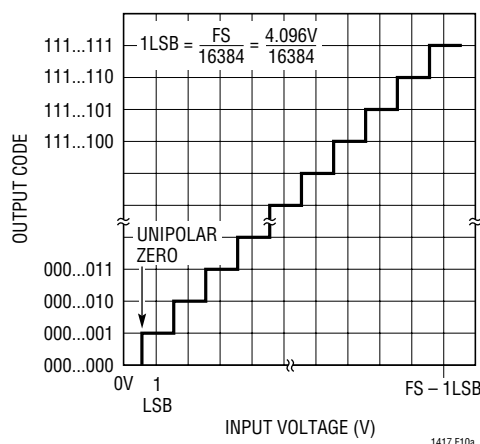

Figure 10a. LTC1417 Unipolar Transfer Characteristics

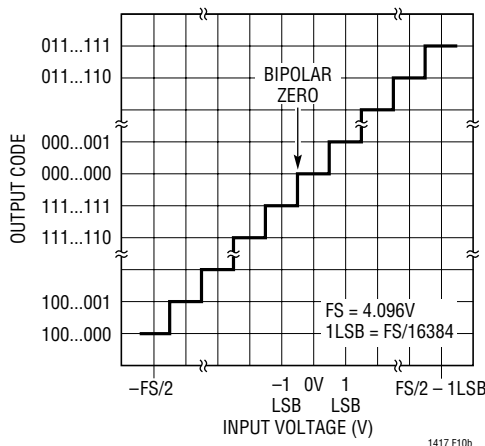

Figure 10b. LTC1417 Bipolar Transfer Characteristics

sn1417 1417fas

APPLICATIONS INFORMATION

Unipolar Offset and Full-Scale Error Adjustment

In applications where absolute accuracy is important, offset and full-scale errors can be adjusted to zero. Offset error must be adjusted before full-scale error. Figures 11a and 11b show the extra components required for full-scale error adjustment. Zero offset is achieved by adjusting the offset applied to the A_{IN}^- input. For zero offset error, apply $125\mu\text{V}$ (i.e., 0.5LSB) at the input and adjust the offset at the A_{IN}^- input until the output code flickers between 0000 0000 0000 00 and 0000 0000 0000 01. For full-scale adjustment, an input voltage of 4.095625V ($\text{FS} - 1.5\text{LSBs}$) is applied to A_{IN}^+ and R2 is adjusted until the output code flickers between 1111 1111 1111 10 and 1111 1111 1111 11.

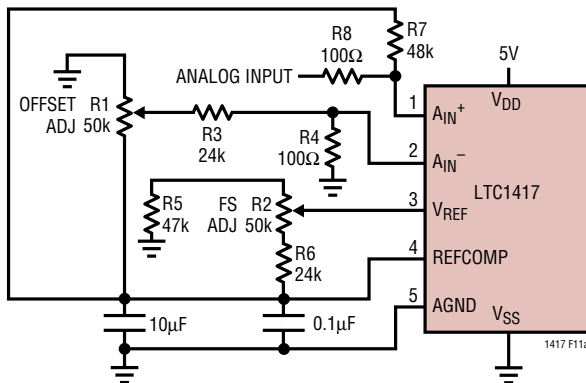

**Figure 11a. Offset and Full-Scale Adjust Circuit
If -5V Is Not Available**

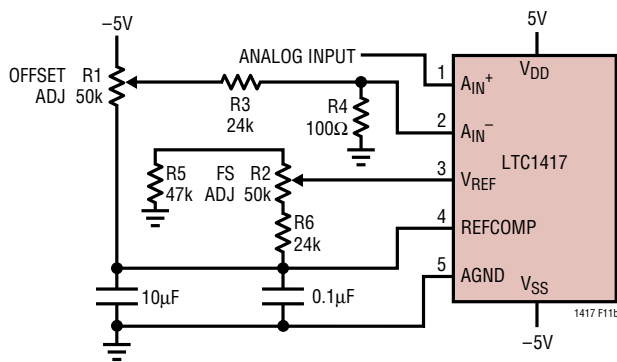

**Figure 11b. Offset and Full-Scale Adjust Circuit
If -5V Is Available**

Bipolar Offset and Full-Scale Error Adjustment

Bipolar offset and full-scale errors are adjusted in a similar fashion to the unipolar case using the circuit in Figure 11b. Again, bipolar offset error must be adjusted before full-scale error. Bipolar offset error adjustment is achieved by adjusting the offset applied to the A_{IN}^- input. For zero offset error, apply $-125\mu\text{V}$ (i.e., -0.5LSB) at A_{IN}^+ and adjust the offset at the A_{IN}^- input until the output code flickers between 0000 0000 0000 00 and 1111 1111 1111 11. For full-scale adjustment, an input voltage of 2.047625V ($\text{FS} - 1.5\text{LSBs}$) is applied to A_{IN}^+ and R2 is adjusted until the output code flickers between 0111 1111 1111 10 and 0111 1111 1111 11.

BOARD LAYOUT AND GROUNDING

To obtain the best performance from the LTC1417, a printed circuit board with ground plane is required. The ground plane under the ADC area should be as free of breaks and holes as possible, such that a low impedance path between all ADC grounds and all ADC decoupling capacitors is provided. It is critical to prevent digital noise from being coupled to the analog input, reference or analog power supply lines. Layout should ensure that digital and analog signal lines are separated as much as possible. In particular, care should be taken not to run any digital track alongside an analog signal track.

An analog ground plane separate from the logic system ground should be established under and around the ADC. Pin 5 (AGND) and Pin 10 (DGND) and all other analog grounds should be connected to this single analog ground plane. The REFCOMP bypass capacitor and the V_{DD} bypass capacitor should also be connected to this analog ground plane. No other digital grounds should be connected to this analog ground plane. Low impedance analog and digital power supply common returns are essential to low noise operation of the ADC and the foil width for these tracks should be as wide as possible. In applications where the ADC data outputs and control signals are connected to a continuously active microprocessor bus, it is possible to get errors in the conversion results. These errors are due to feedthrough from the microprocessor to the successive approximation comparator. The problem can be eliminated by forcing the microprocessor into a

APPLICATIONS INFORMATION

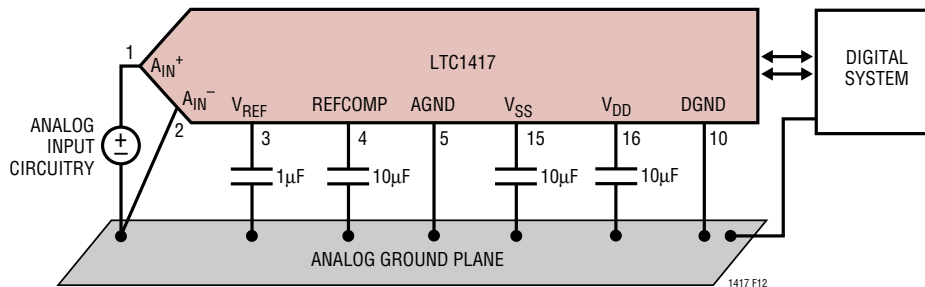

Figure 12. Power Supply Grounding Practice

wait state during conversion or by using three-state buffers to isolate the ADC data bus. The traces connecting the pins and bypass capacitors must be kept short and should be made as wide as possible.

The LTC1417 has differential inputs to minimize noise coupling. Common mode noise on the A_{IN}^+ and A_{IN}^- leads will be rejected by the input CMRR. The A_{IN}^- input can be used as a ground sense for the A_{IN}^+ input; the LTC1417 will hold and convert the difference voltage between A_{IN}^+ and A_{IN}^- . The leads to A_{IN}^+ (Pin 1) and A_{IN}^- (Pin 2) should be kept as short as possible. In applications where this is not possible, the A_{IN}^+ and A_{IN}^- traces should be run side by side to equalize coupling.

SUPPLY BYPASSING

High quality, low series resistance ceramic, $10\mu\text{F}$ bypass capacitors should be used at the V_{DD} and REFCOMP pins. Surface mount ceramic capacitors such as Taiyo Yuden LMK325BJ106MN provide excellent bypassing in a small board space. Alternatively $10\mu\text{F}$ tantalum capacitors in parallel with $0.1\mu\text{F}$ ceramic capacitors can be used.

Bypass capacitors must be located as close to the pins as possible. The traces connecting the pins and the bypass capacitors must be kept short and should be made as wide as possible.

Example Layout

Figures 13a, 13b, 13c and 13d show the schematic and layout of a suggested evaluation board. The layout demonstrates the proper use of decoupling capacitors and ground plane with a 2-layer printed circuit board.

POWER SHUTDOWN

The LTC1417 provides two power shutdown modes, Nap and Sleep, to save power during inactive periods. The Nap mode reduces ADC power dissipation by 80% and leaves only the digital logic and reference powered up. The wake-up time from Nap to active is 500ns (see Figure 14). In Sleep mode, all bias currents are shut down and only leakage current remains—about $2\mu\text{A}$. Wake-up time from Sleep mode is much slower since the reference circuit must power up and settle to 0.005% for full 14-bit accuracy. Sleep mode wake-up time is dependent on the value of the capacitor connected to the REFCOMP (Pin 4). The wake-up time is 30ms with the recommended $10\mu\text{F}$ capacitor. Shutdown is controlled by Pin 11 (SHDN); the ADC is in shutdown when it is low. The shutdown mode is selected with Pin 12 ($\overline{\text{RD}}$); low selects Nap mode, high selects Sleep mode.

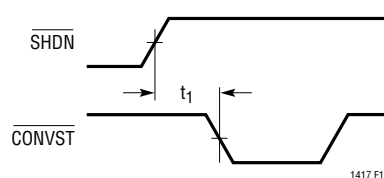

Figure 14. SHDN to CONVST Wake-Up Timing

APPLICATIONS INFORMATION

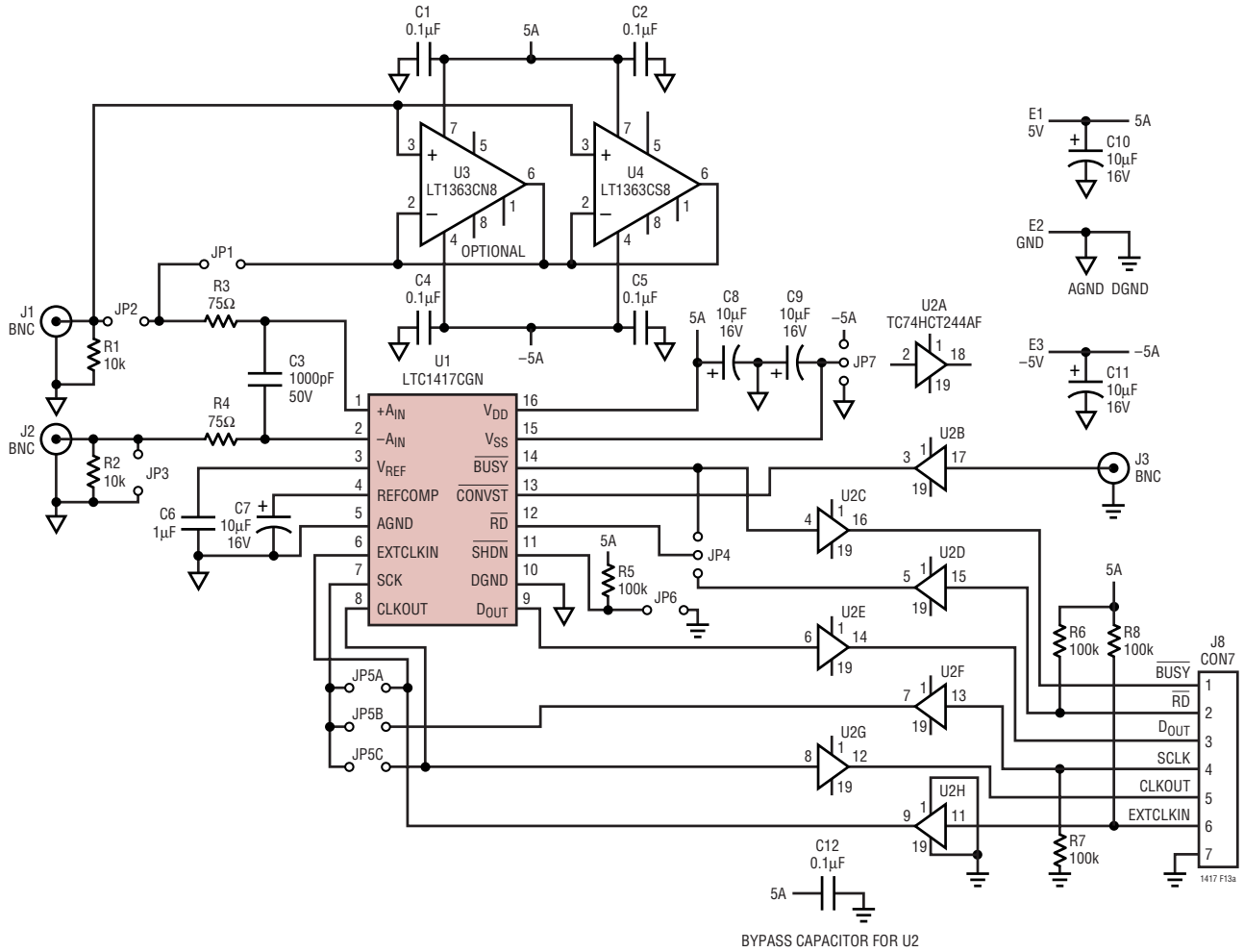

Figure 13a. Suggested Evaluation Circuit Schematic

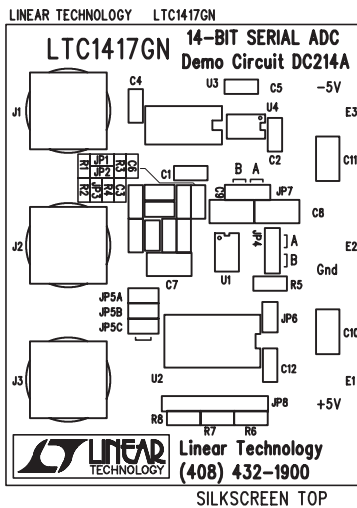

Figure 13b. Suggested Evaluation Circuit Board—Component Side Silkscreen

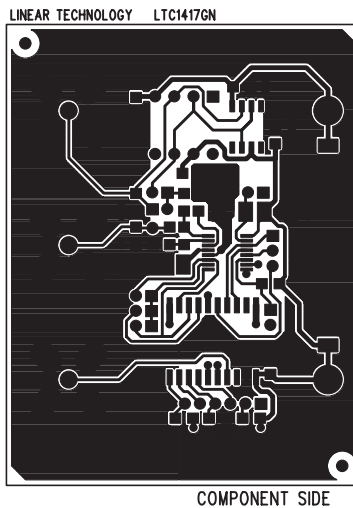

Figure 13c. Suggested Evaluation Circuit Board—Component Side

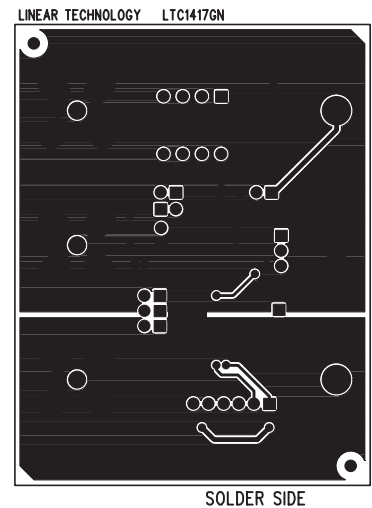

Figure 13d. Suggested Evaluation Circuit Board—Solder Side

sn1417 1417fas

APPLICATIONS INFORMATION

DIGITAL INTERFACE

The LTC1417 operates in serial mode. The \overline{RD} control input is common to all peripheral memory interfacing. Only four digital interface lines are required, SCLK, \overline{CONVST} , EXTCLKIN and D_{OUT}. SCLK, the serial data shift clock can be an external input or supplied by the LTC1417's internal clock.

Internal Clock

The ADC has an internal clock. Either the internal clock or an external clock may be used as the conversion clock (see Figure 15). The internal clock is factory trimmed to achieve a typical conversion time of 1.8 μ s, and a maximum conversion time over the full operating temperature range of 2.5 μ s. No external adjustments are required, and with the guaranteed maximum acquisition time of 0.5 μ s, throughput performance of 400ksp/s is assured.

Conversion Control

Conversion start is controlled by the signal applied to the \overline{CONVST} input. A falling edge on the signal applied to the \overline{CONVST} pin starts a conversion. Once initiated, it cannot be restarted until the conversion is complete. Converter

status is indicated by the \overline{BUSY} output. \overline{BUSY} is low during a conversion.

Data Output

Output will be active when \overline{RD} is low. A high \overline{RD} will three-state the output. In unipolar mode ($V_{SS} = 0V$), the data will be in straight binary format (corresponding to the unipolar input range). In bipolar mode ($V_{SS} = -5V$), the data will be in two's complement format (corresponding to the bipolar input range).

Serial Output Mode

Conversions are started by a falling \overline{CONVST} edge. After a conversion is completed and the output shift register has been updated, \overline{BUSY} will go high and valid data will be available on D_{OUT} (Pin 9). This data can be clocked out either before the next conversion starts or it can be clocked out during the next conversion. To enable the serial data output buffer and shift clock, \overline{RD} must be low.

Figure 15 shows a function block diagram of the LTC1417. There are two pieces to this circuitry: the conversion clock selection circuit (EXTCLKIN and CLKOUT) and the serial port (SCLK, D_{OUT} and \overline{RD}).

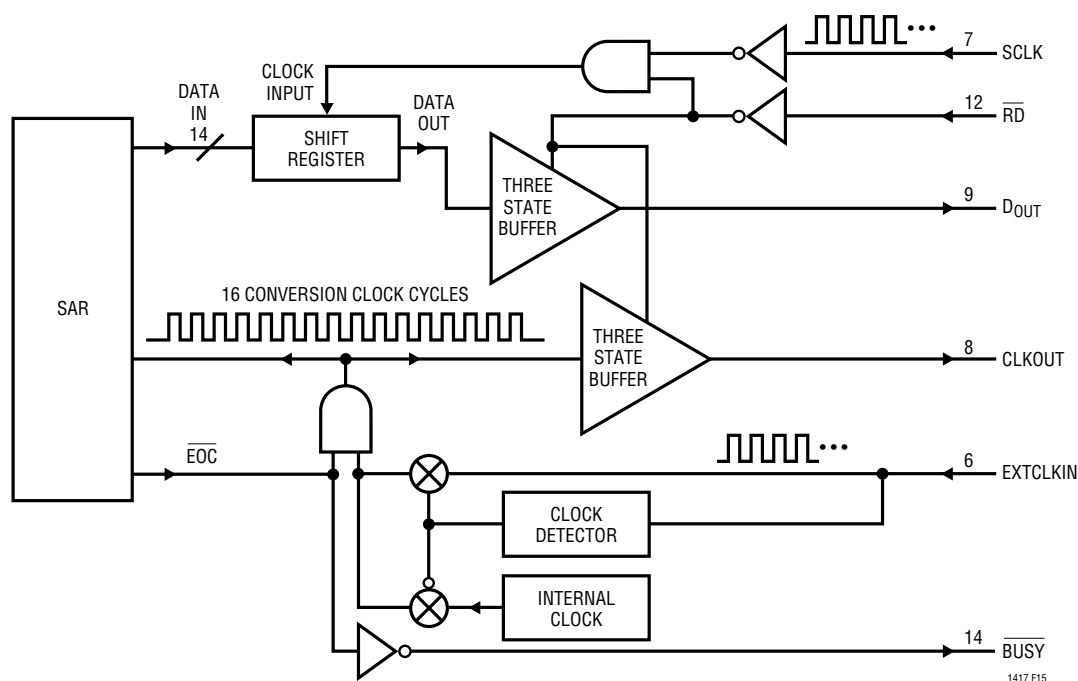

Figure 15. Functional Block Diagram

APPLICATIONS INFORMATION

Conversion Clock Selection

In Figure 15, the conversion clock controls the internal ADC operation. The conversion clock can be either internal or external. By connecting EXTCLKIN high, the internal clock is selected. This clock generates 16 clock cycles which feed into the SAR for each conversion.

To select an external conversion clock, apply an external conversion clock to EXTCLKIN (Pin 6). (When an external shift clock (SCLK) is used during a conversion, the SCLK should be used as the external conversion clock to avoid the noise generated by the asynchronous clocks. To maintain accuracy, the external conversion clock frequency must be between 50kHz and 9MHz.) The SAR sends an end of conversion signal, \overline{EOC} , that gates the external conversion clock so that only 16 clock cycles can go into the SAR, even if the external clock, EXTCLKIN, contains more than 16 cycles.

When \overline{RD} is low, these 16 cycles of conversion clock (whether internally or externally generated) will appear on CLKOUT during each conversion and then CLKOUT will remain low until the next conversion. If desired, CLKOUT can be used as a master clock to drive the serial port. Because CLKOUT is running during the conversion, it is important to avoid excessive loading that can cause large supply transients and create noise. For the best performance, limit CLKOUT loading to 20pF.

Serial Port

The serial port in Figure 15 is made up of a 16-bit shift register and a three-state output buffer that are controlled by two inputs: SCLK and \overline{RD} . The serial port has one output, D_{OUT} , that provides the serial output data.

The SCLK is used to clock the shift register. Data may be clocked out with the internal conversion clock operating as a master by connecting CLKOUT (Pin 8) to SCLK (Pin 7) or with an external data clock applied to SCLK. The minimum number of SCLK cycles required to transfer a data word is 14. Normally, SCLK contains 16 clock cycles for a word length of 16 bits; 14 bits with MSB first, followed by two trailing zeros.

A logic high on \overline{RD} disables SCLK and three-states D_{OUT} . In case of using a continuous SCLK, \overline{RD} can be controlled to limit the number of shift clocks to the desired number (i.e., 16 cycles) and to three-state D_{OUT} after the data transfer.

In power shutdown mode ($\overline{SHDN} = \text{low}$), a high \overline{RD} selects Sleep mode while a low \overline{RD} selects Nap mode.

D_{OUT} outputs the serial data; 14 bits, MSB first, on the falling edge of each SCLK (see Figures 16 and 17). If 16 SCLKs are provided, the 14 data bits will be followed by two zeros. The MSB (D13) will be valid on the first rising and the first falling edge of the SCLK. D12 will be valid on the second rising and the second falling edge as will all the remaining bits. The data may be captured using either edge. The largest hold time margin is achieved if data is captured on the rising edge of SCLK.

\overline{BUSY} gives the end-of-conversion indication. When the LTC1417 is configured as a serial bus master, \overline{BUSY} can be used as a framing pulse. To three-state the serial port after transferring the serial output data, \overline{BUSY} and \overline{RD} should be connected together at the ADC (see Figure 17).

Figures 17 to 20 show several serial modes of operation, demonstrating the flexibility of the LTC1417 serial interface.

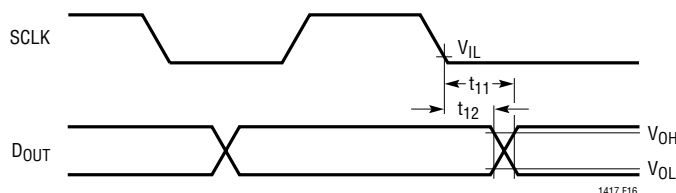

Figure 16. SCLK to D_{OUT} Delay

APPLICATIONS INFORMATION

Serial Data Output During a Conversion

Using Internal Clock for Conversion and Data Transfer.

Figure 17 shows data from the previous conversion being clocked out during the conversion with the LTC1417 internal clock providing both the conversion clock and the SCLK. The internal clock has been optimized for the fastest

conversion time; consequently, this mode can provide the best overall speed performance. To select the internal conversion clock, tie EXTCLKIN (Pin 6) high. The internal clock appears on CLKOUT (Pin 8) which can be tied to SCLK (Pin 7) to supply the SCLK.

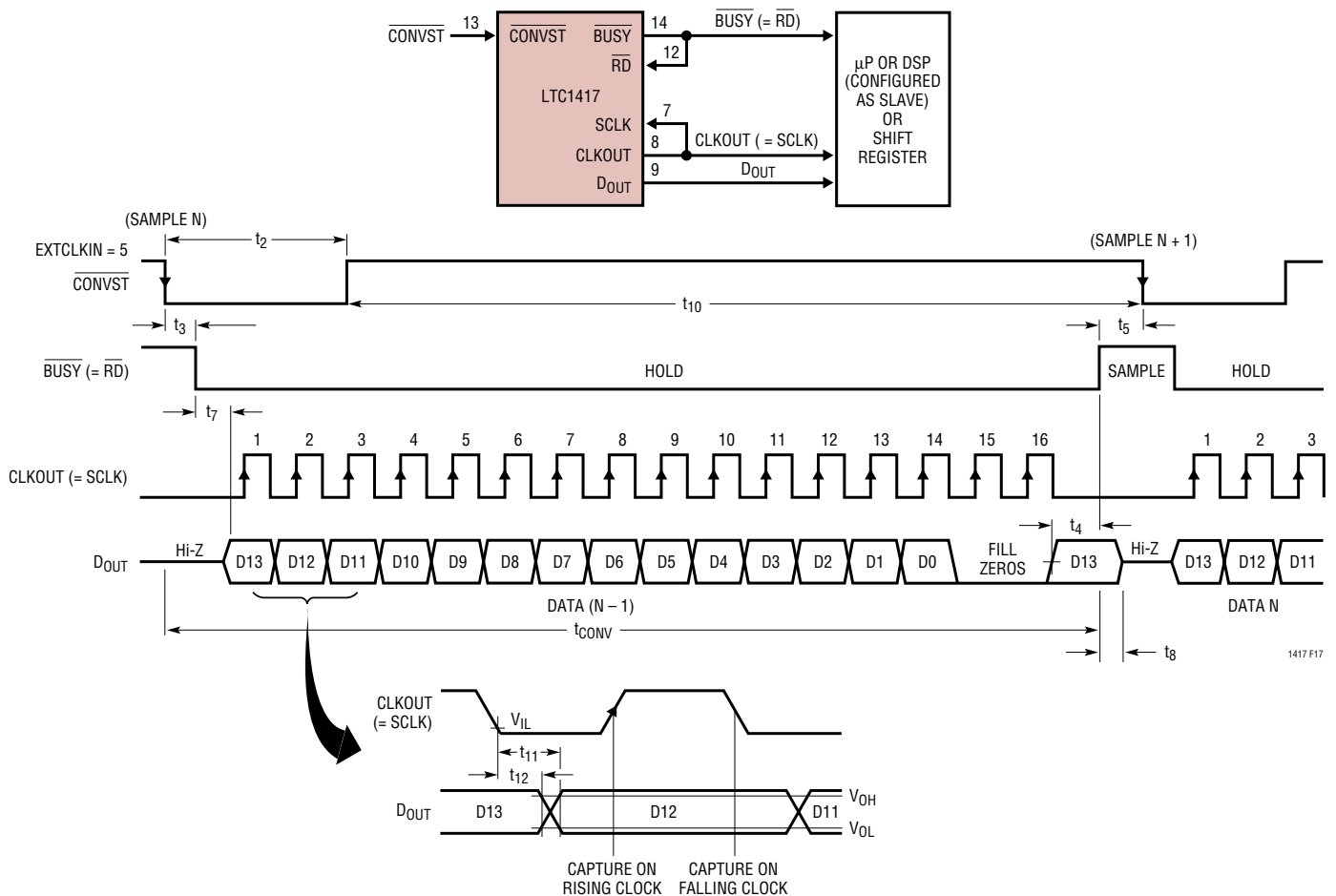

Figure 17. Internal Conversion Clock Selected. Data Transferred During Conversion Using the ADC Clock Output as a Master Shift Clock (SCLK Driven from CLKOUT)

APPLICATIONS INFORMATION

Using External Clock for Conversion and Data Transfer. In Figure 18, data from the previous conversion is output during the conversion with an external clock providing both the conversion clock and the shift clock. To select an external conversion clock, apply the clock to EXTCLKIN. The same clock is also applied to SCLK to provide a data

shift clock. To maintain conversion accuracy, the external clock frequency must be between 50kHz and 9MHz.

Using an external clock to transfer data while an internal clock controls the conversion process is not recommended. As both signals are asynchronous, clock noise can corrupt the conversion result.

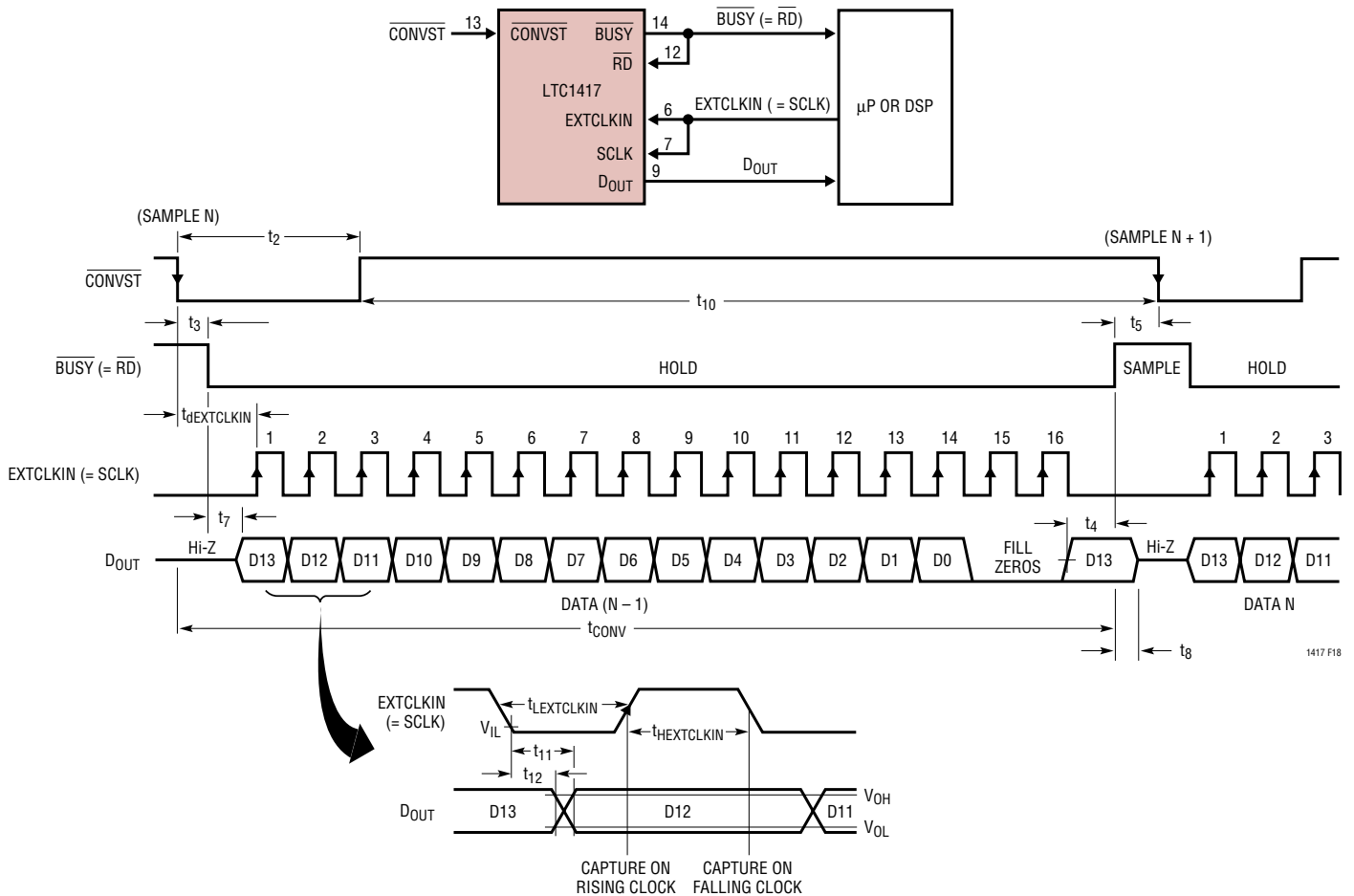

Figure 18. External Conversion Clock Selected. Data Transferred During Conversion Using the External Clock (External Clock Drives Both EXTCLKIN and SCLK)

APPLICATIONS INFORMATION

Serial Data Output After a Conversion

Using an Internal Conversion Clock and an External Data Clock. In this mode, data is output after the end of each conversion and before the next conversion is started (Figure 19). The internal clock is used as the conversion clock and an external clock is used for the SCLK. This mode is useful in applications where the processor acts as a serial bus master device. This mode is SPI and

MICROWIRE™ compatible. It also allows operation when the SCLK frequency is very low (less than 30kHz). To select the internal conversion clock, tie EXTCLKIN high. The external SCLK is applied to SCLK. RD can be used to gate the external SCLK, such that data will clock only after RD goes low and to three-state D_{OUT} after data transfer. If more than 16 SCLKs are provided, more zeros will be filled in after the data word indefinitely.

MICROWIRE is a trademark of National Semiconductor Corporation.

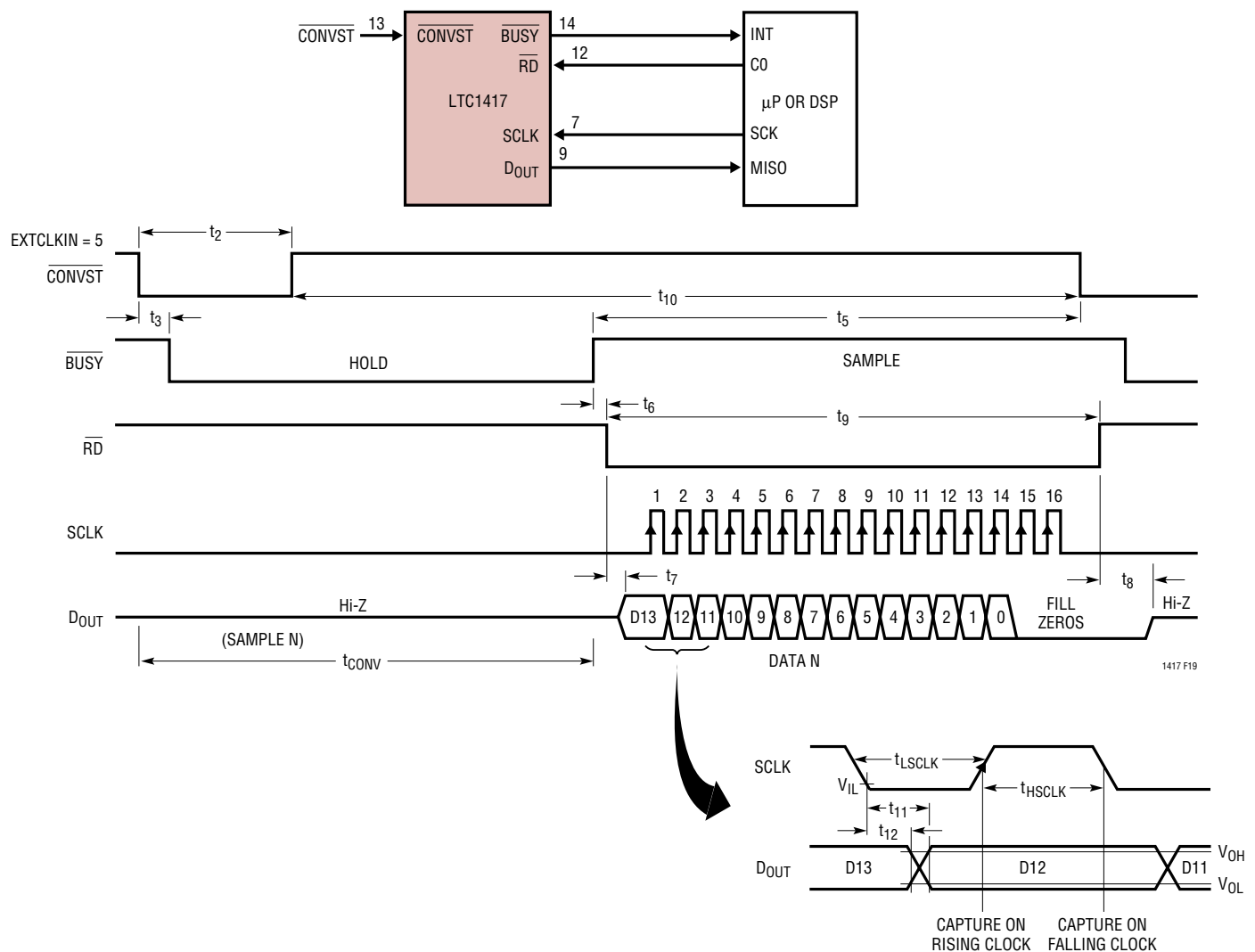

Figure 19. Internal Conversion Clock Selected. Data Transferred After Conversion Using an External SCLK. BUSY↑ Indicates End of Conversion

APPLICATIONS INFORMATION

Using an External Conversion Clock and an External Data Clock. In Figure 20, data is also output after each conversion is completed and before the next conversion is started. An external clock is used for the conversion clock and either another or the same external clock is used for the SCLK. This mode is identical to Figure 19 except that an external clock is used for the conversion. This mode allows the user to synchronize the A/D conversion to an external clock either to have precise control of the internal bit test timing or to provide a precise conversion time. As in

Figure 19, this mode works when the SCLK frequency is very low (less than 30kHz). However, the external conversion clock must be between 30kHz and 9MHz to maintain accuracy. If more than 16 SCLKs are provided, more zeros will be filled in after the data word indefinitely. To select the external conversion clock, apply an external conversion clock to EXTCLKIN. The external SCLK is applied to SCLK. \overline{RD} can be used to gate the external SCLK such that data will be clocked out only after \overline{RD} goes low.

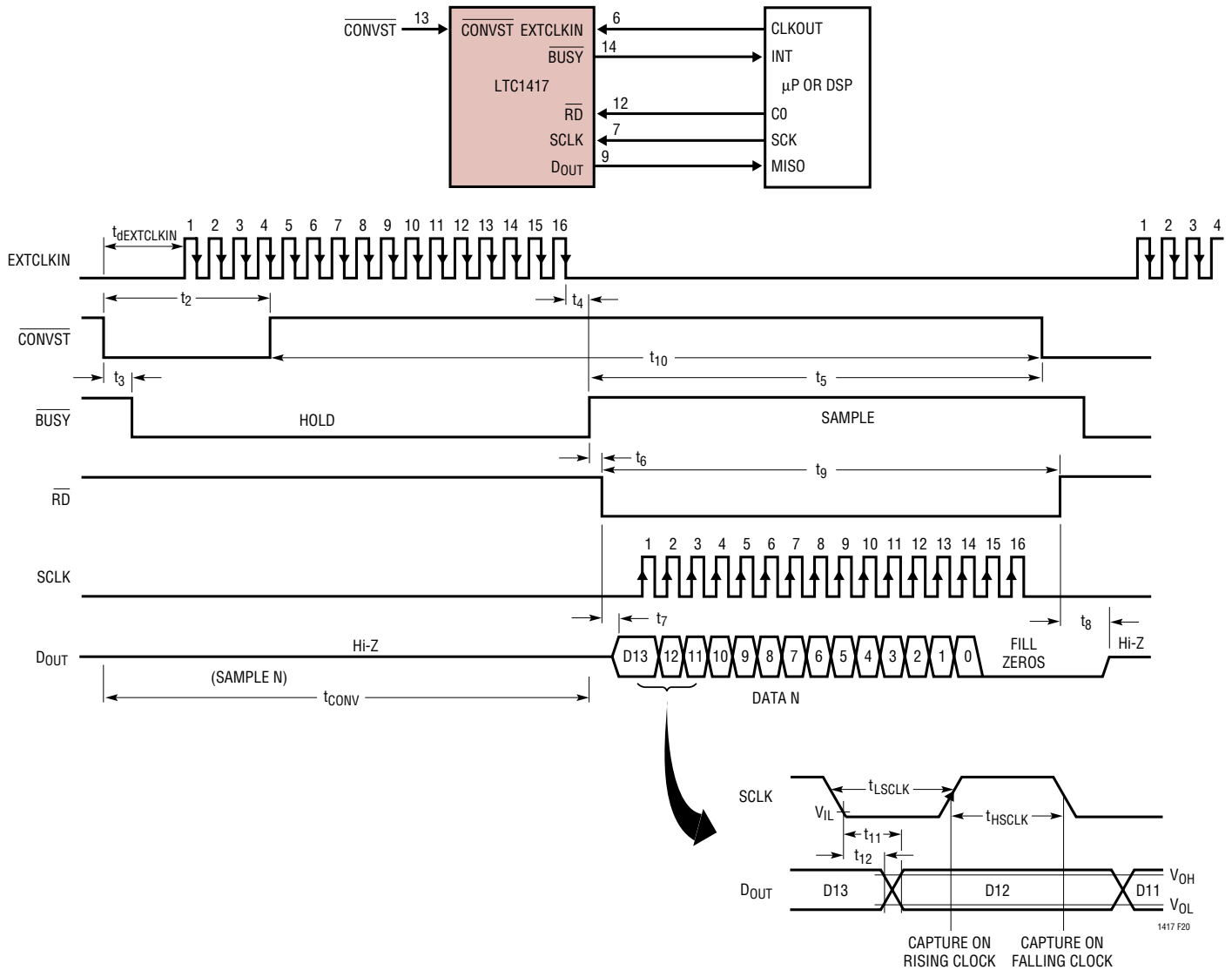

Figure 20. External Conversion Clock Selected. Data Transferred After Conversion Using an External SCLK. BUSY↑ Indicates End of Conversion

TYPICAL APPLICATIONS

Figure 21 shows the connections necessary for interfacing the LTC1417 and LTC1391 8-channel signal acquisition system to an SPI port. With the sample software routine shown in Listing A, the SPI uses MOSI to send serial data to the LTC1391 8-channel multiplexer, selecting one of eight MUX channels.

While data is sent to the LTC1391, SPI uses MISO to retrieve conversion data from the LTC1417. After the data transfer is complete, the conversion start signal is sent to

the LTC1417. The end of conversion is signaled by a logic high on the $\overline{\text{BUSY}}$ output. When this occurs, data is exchanged between the LTC1417/LTC1391 and the controller.

The timing diagram in Figure 22 shows the relation between MUX channel selection data and the conversion data that are simultaneously exchanged. There is a two conversion delay between the MUX data selects a given channel and when that channel's data is retrieved.

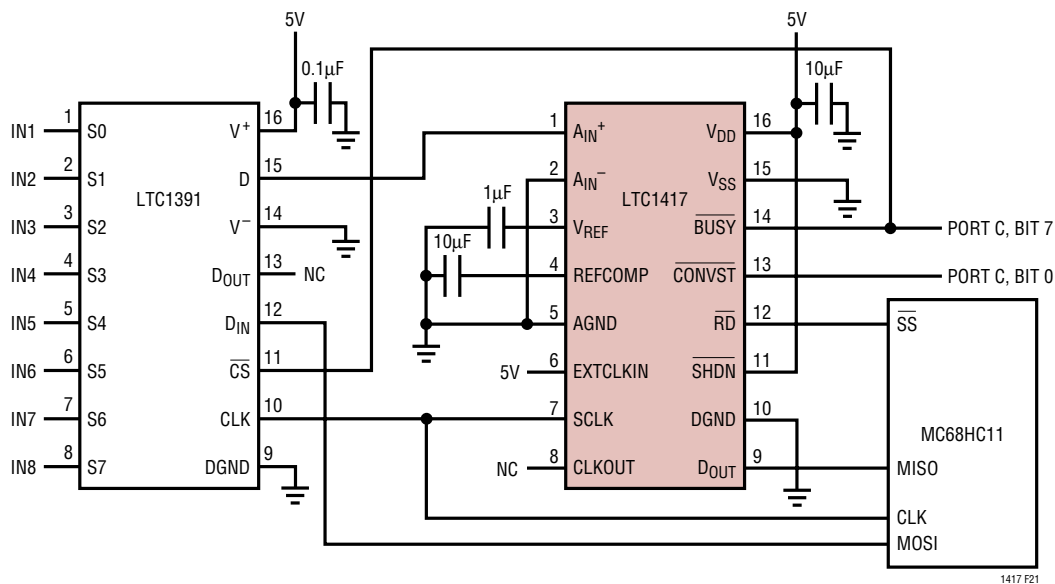

Figure 21. 0V to 4.096V, 8-Channel Data Acquisition System Configured for Control and Data Retrieval by a 68HC11 µC. Code is Shown in Listing A

TYPICAL APPLICATIONS

Listing A

```

*****
*
* This example program retrieves data from a previous LTC1417
* conversion and loads the next LTC1391 MUX channel. It stores the
* 14-bit, right justified data in two consecutive memory locations.
* It finishes by initiating the next conversion.
*
*****
*
*****
* 68HC11 register definitions *
*****
*
PIOC EQU $1002 Parallel I/O control register
* "STAF,STAI,CWOM,HNDS, OIN, PLS, EGA,INVB"
PORTC EQU $1003 Port C data register
* "Bit7,Bit6,Bit5,Bit4,Bit3,Bit2,Bit1,Bit0"
DDRC EQU $1007 Port D data direction register
* "Bit7,Bit6,Bit5,Bit4,Bit3,Bit2,Bit1,Bit0"
* 1 = output, 0 = input
PORTD EQU $1008 Port D data register
* " - , - , SS* ,CSK ;MOSI,MISO,TxD ,RxD "
DDRD EQU $1009 Port D data direction register
SPCR EQU $1028 SPI control register
* "SPIE,SPE ,DWOM,MSTR;SPOL,CPHA,SPR1,SPR0"
SPSR EQU $1029 SPI status register
* "SPIF,WCOL, - ,MODF; - , - , - , - "
SPDR EQU $102A SPI data register; Read-Buffer; Write-Shifter
*
* RAM variables to hold the LTC1417's 14 conversion result
*
DIN1 EQU $00 This memory location holds the LTC1417's bits 13 - 08
DIN2 EQU $01 This memory location holds the LTC1417's bits 07 - 00
MUX EQU $02 This memory location holds the MUX address data
*
*****
* Start GETDATA Routine *
*****
*
ORG $C000 Program start location
INIT1 LDAA #$03 0,0,0,0,0,0,1,1
* "STAF=0,STAI=0,CWOM=0,HNDS=0, OIN=0, PLS=0, EGA=1,INVB=1"
* STAA PIOC Ensures that the PIOC register's status is the same
* as after a reset, necessary of simple Port D manipulation
LDAA #$01 0,0,0,0,0,0,0,1
* "Bit7=input,-,-,-,-,-,-,-,Bit0=output"
* Bit7 used for BUSY signal input, Bit0 used for CONVST
* signal output
STAA DDRC The direction of PortD's bits are now set
LDAA PORTC Get contents of Port C
ORAA #%00000001 Set Bit0 high
STAA PORTC Initialize CONVST to a logic high
LDAA #$2F -,-,1,0;1,1,1,1
* -, -, SS*-Hi, SCK-Lo, MOSI-Hi, MISO-Hi, X, X
STAA PORTD Keeps SS* a logic high when DDRD, bit 5 is set
LDAA #$38 -, -,1,1;1,0,0,0
STAA DDRD SS* , SCK, MOSI are configured as Outputs
* MISO, TxD, RxD are configured as Inputs
* DDRD's bit 5 is a 1 so that port D's SS* pin is a general output
LDAA #$50
STAA SPCR The SPI is configured as Master, CPHA = 0, CPOL = 0
* and the clock rate is E/2

```

TYPICAL APPLICATIONS

```

*           (This assumes an E-Clock frequency of 4MHz. For higher
*           E-Clock frequencies, change the above value of $50 to a
*           value that ensures the SCK frequency is 2MHz or less.)
GETDATAPSHX
    PSHY
    PSHA
*
*****
* Setup indecies                                     *
*****
*
    LDX    #$0    The X register is used as a pointer to the memory
*           locations that hold the conversion data
    LDY    #$1000
*
*****
* The next short loop ensures that the *
* LTC1417's conversion is finished *
* before starting the SPI data transfer *
*****
*
CONVENDLDAA    PORTC    Retrieve the contents of port D
    ANDA    #%10000000    Look at Bit7
*           Bit7 = Hi; the LTC1417's conversion is complete
*           Bit7 = Lo; the LTC1417's conversion is not
*           complete
    BPL    CONVEND    Branch to the loop's beginning while Bit7 remains
*           low
*
*****
* This routine sends data to the LTC1417 and sets its MUX channel. The *
* very first time this routine is entered produces invalid data. Each *
* time thereafter, the data will correspond to the previous active *
* CONVST signal sent to the LTC1417. *
*****
*
    LDAA    #$00    Dummy value for upper byte of 16-bit SPI transfer
    BCLR    PORTD,Y %00100000    This sets the SS* output bit to a logic
*           low, selecting the LTC1417
    STAA    SPDR    Transfer Accum. A contents to SPI register to initiate
*           serial transfer
WAITMX1 LDAA    SPSR    Get SPI transfer status
    BPL    WAITMX1If the transfer is not finished, read status
    LDAA    SPDR    Load accumulator A with the current byte of LTC1417 data
*           that was just received
    STAA    DIN1    Transfer the LTC1417's high byte (Bit13 - Bit6) to memory
    LDAA    MUX    Retrieve MUX address
    ORAA    #$08    Set the MUX's ENABLE bit
    STAA    SPDR    Transfer Accum. A contents to SPI register to initiate
*           serial transfer
WAITMX2 LDAA    SPSR    Get SPI transfer status
    BPL    WAITMX2If the transfer is not finished, read status
    BSET    PORTD,Y %00100000    This sets the SS* output bit to a logic
*           high, de-selecting the LTC1417
    LDAA    SPDR    Load accumulator A with the current byte of LTC1417 data
*           that was just received
    STAA    DIN2    Transfer the LTC1417's low byte (Bit5 - Bit0) to memory
    LDD    DIN1    Load the contents of DIN1 and DIN2 into the double
*           accumulator D
    LSRD
    LSRD
*           Two logical shifts to the right to right justify the
*           14-bit conversion results
    STD    DIN1    Place right justified result back in memory

```

TYPICAL APPLICATIONS

```

*
*****
* Initiate a LTC1417 conversion *
*****
*
    BCLR  PORTC,Y %00000001  This sets PORTC, Bit0 output to a logic
*                               low, initiating a conversion
    BSET  PORTC,Y %00000001  This resets PORTC, Bit0 output to a logic
*                               high, returning CONVST to a logic high
*
    PULA          Restore the A register
    PULY          Restore the Y register
    PULX          Restore the X register
    RTS
    
```

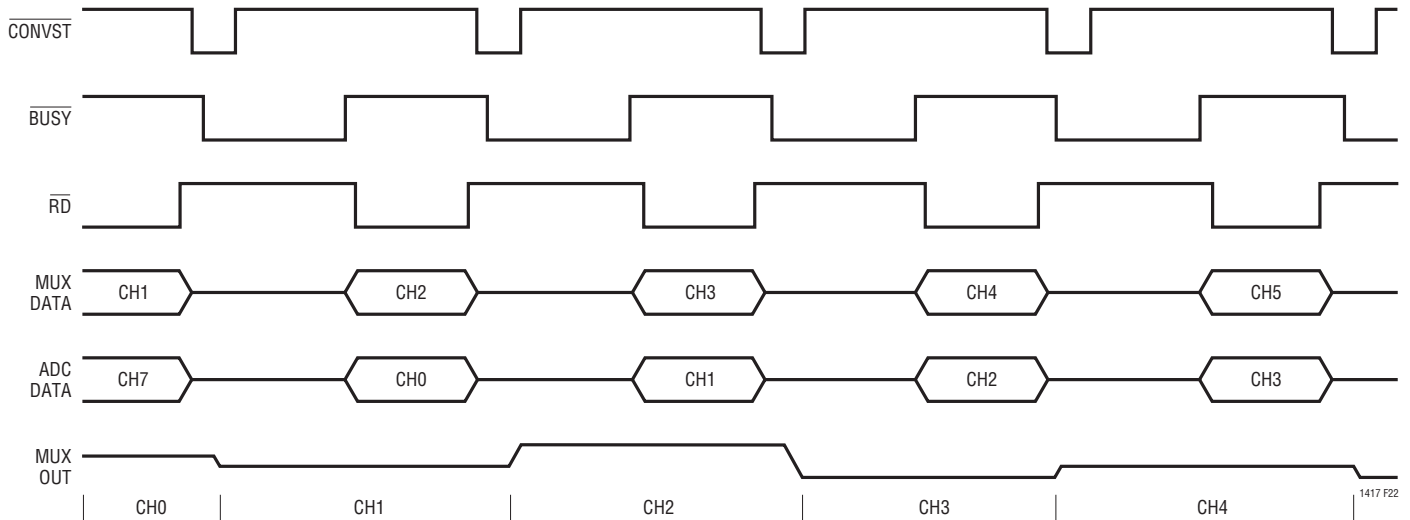

Figure 22. This Diagram Shows the Relationship Between the Selected LTC1391 MUX Channel and the Conversion Data Retrieved from the LTC1417 When Using the Sample Program in Listing A. At Any Point in Time, a Two Conversion Delay Exists Between the Selected MUX Channel and When Its Data Is Retrieved

TYPICAL APPLICATIONS

Figure 23 uses the DG408 to select one of eight $\pm 2.048V$ bipolar signals and apply it to the LTC1417's analog input. The circuit is designed to connect to a 68HC11 μC . The MUX's parallel input is connected to the controller's port C and the LTC1417's serial interface is accessed through the controller's SPI interface.

The sequence to generate a conversion is shown in sample program Listing B. The first step selects a MUX channel. This is followed by initiating a conversion and waiting for \overline{BUSY} to go high, signifying end of conversion. Once \overline{BUSY} goes low, the SPI is used to retrieve the 14-bit conversion data. The timing relationships between the various control signals and data transmission are shown in Figure 24.

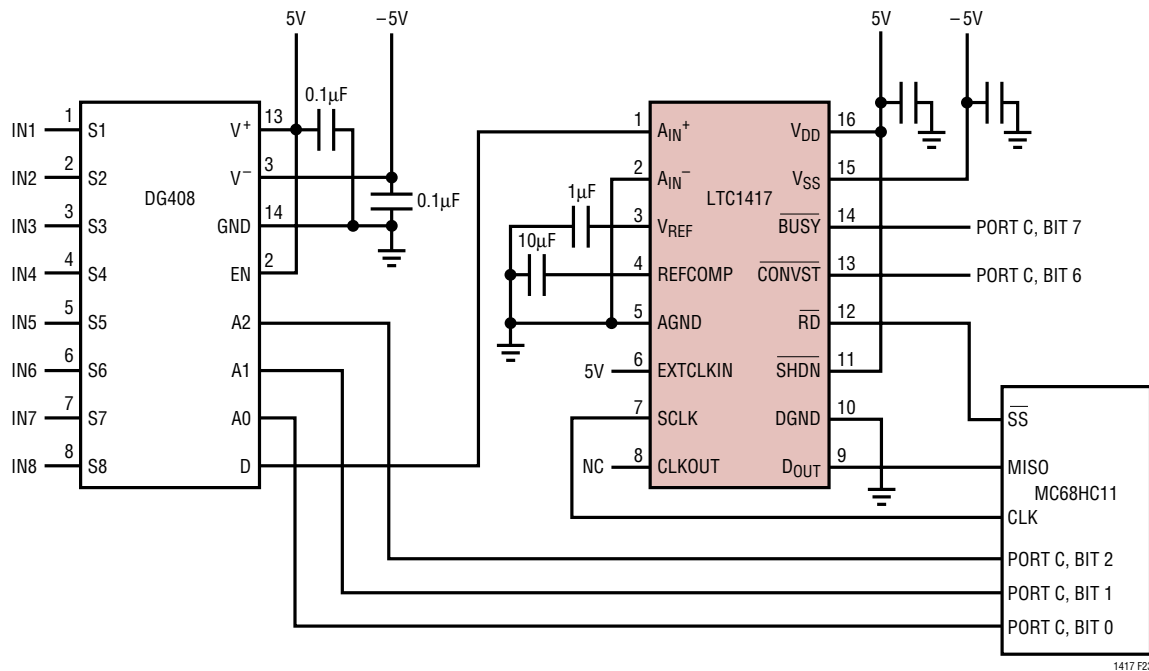

Figure 23. With an Input Range of $\pm 2.048V$ for Each of Eight Inputs, This Data Acquisition System is Configured for Communication with the 68HC11 μC

TYPICAL APPLICATIONS

Listing B

```

*****
*
* This example program selects a DG408 MUX channel using parallel
* port C, initiates a conversion, and retrieves data from the LTC1417.
* It stores the 14-bit, right justified data in two consecutive memory
* locations.
*
*****
*
*****
* 68HC11 register definitions
*****
*
PIOC EQU $1002 Parallel I/O control register
* "STAF,STAI,CWOM,HNDS, OIN, PLS, EGA,INVB"
PORTC EQU $1003 Port C data register
* "Bit7,Bit6,Bit5,Bit4,Bit3,Bit2,Bit1,Bit0"
DDRC EQU $1007 Port D data direction register
* "Bit7,Bit6,Bit5,Bit4,Bit3,Bit2,Bit1,Bit0"
* 1 = output, 0 = input
PORTD EQU $1008 Port D data register
* " - , - , SS* ,CSK ;MOSI,MISO,TxD ,RxD "
DDRD EQU $1009 Port D data direction register
SPCR EQU $1028 SPI control register
* "SPIE,SPE ,DWOM,MSTR;SPOL,CPHA,SPR1,SPR0"
SPSR EQU $1029 SPI status register
* "SPIF,WCOL, - ,MODF; - , - , - , - "
SPDR EQU $102A SPI data register; Read-Buffer; Write-Shifter
*
* RAM variables to hold the LTC1417's 14 conversion result
*
DIN1 EQU $00 This memory location holds the LTC1417's bits 13 - 08
DIN2 EQU $01 This memory location holds the LTC1417's bits 07 - 00
MUX EQU $02 This memory location holds the MUX address data
*
*****
* Start GETDATA Routine
*****
*
ORG $C000 Program start location
INIT1 LDAA #$03 0,0,0,0,0,0,1,1
* "STAF=0,STAI=0,CWOM=0,HNDS=0, OIN=0, PLS=0, EGA=1,INVB=1"
* STAA PIOC Ensures that the PIOC register's status is the same
* as after a reset, necessary of simple Port D manipulation
* LDAA #$47 0,1,0,0,0,1,1,1
* "Bit7=input,Bit6=output,- ,- ,- ,Bit2=output,Bit1=output,
* Bit0=output"
* Bit7 used for BUSY input
* Bit6 used for CONVST signal output
* Bits 2 - 0 are used for the MUX address
* STAA DDRC Direction of PortD's bit are now set
* LDAA #$2F -,-,1,0;1,1,1,1
* -, -, SS*-Hi, SCK-Lo, MOSI-Hi, MISO-Hi, X, X
* STAA PORTD Keeps SS* a logic high when DDRD, Bit5 is set
* LDAA #$38 -,-,1,1;1,0,0,0
* STAA DDRD SS* , SCK, MOSI are configured as Outputs
* MISO, TxD, RxD are configured as Inputs
* DDRD's Bit5 is a 1 so that port D's SS* pin is a general output
* LDAA #$50
* STAA SPCR The SPI is configured as Master, CPHA = 0, CPOL = 0
* and the clock rate is E/2
* (This assumes an E-Clock frequency of 4MHz. For higher

```

TYPICAL APPLICATIONS

```

*           E-Clock frequencies, change the above value of $50 to a
*           value that ensures the SCK frequency is 2MHz or less.)
GETDATAPSHX
    PSHY
    PSHA
*
*****
* Setup indecies
*****
*
    LDX    #$0    The X register is used as a pointer to the memory
*           locations that hold the conversion data
    LDY    #$1000
*
*****
* Initialize the LTC1417's CONVST input
* to a logic high before a conversion
* start
*****
*
    BSET   PORTC,Y %01000000    This sets PORTC, Bit6 output to a logic
*                               high, forcing CONVST to a logic high
*
*****
* Retrieve the MUX address from memory
* and send it to the DG408
*****
*
    LDAA   PORTC    Capture the contents of PortC
    ORAA   MUX      "Add" the MUX address
    STAA   PORTC    Select the MUX channel
*
*****
* Initiate a LTC1417 conversion
*****
*
    BCLR   PORTC,Y %01000000    This sets PORTC, Bit6 output to a logic
*                               low, initiating a conversion
    BSET   PORTC,Y %01000000    This resets PORTC, Bit6 output to a logic
*                               high, returning CONVST to a logic high
*
*****
* The next short loop ensures that the
* LTC1417's conversion is finished
* before starting the SPI data transfer
*****
*
CONVENDLDAA   PORTC    Retrieve the contents of port D
    ANDA    #%10000000    Look at Bit7
*
*                               Bit7 = Hi; the LTC1417's conversion is complete
*                               Bit7 = Lo; the LTC1417's conversion is not
*                               complete
    BPL    CONVEND      Branch to the loop's beginning while Bit7
*                               remains high
*
*****
* This routine sends data to the LTC1417 and sets its MUX channel. The
* very first time this routine is entered produces invalid data. Each
* time thereafter, the data will correspond to the previous active
* CONVST signal sent to the LTC1417.
*****
*

```

TYPICAL APPLICATIONS

```

*      BCLR  PORTD,Y %00100000    This sets the SS* output bit to a logic
*                                  low, selecting the LTC1417
TRFLP1 LDAA  #$0                  Load accumulator A with a null byte for SPI transfer
      STAA  SPDR                  This writes the byte into the SPI data register and
*                                  starts the transfer
WAIT1  LDAA  SPSR                 This loop waits for the SPI to complete a serial
*                                  transfer/exchange by reading the SPI Status Register
*      BPL   WAIT1                The SPIF (SPI transfer complete flag) bit is the SPSR's
*                                  MSB and is set to one at the end of an SPI transfer. The
*                                  branch will occur while SPIF is a zero.
      LDAA  SPDR                  Load accumulator A with the current byte of LTC1417 data
*                                  that was just received
      STAA  0,X                   Transfer the LTC1417's data to memory
      INX                               Increment the pointer
      CPX  #DIN2+1                Has the last byte been transferred/exchanged?
*      BNE  TRFLP1                If the last byte has not been reached, then proceed to
*                                  the next byte for transfer/exchange
*      BSET  PORTD,Y %00100000    This sets the SS* output bit to a logic
*                                  high, de-selecting the LTC1417
*      LDD  DIN1                  Load the contents of DIN1 and DIN2 into the double
*                                  accumulator D
      LSRD
      LSRD                          Two logical shifts to right justify the 14-bit
*                                  conversion results
      STD  DIN1                   Return right justified data to memory
      PULA                          Restore the A register
      PULY                          Restore the Y register
      PULX                          Restore the X register
      RTS
    
```

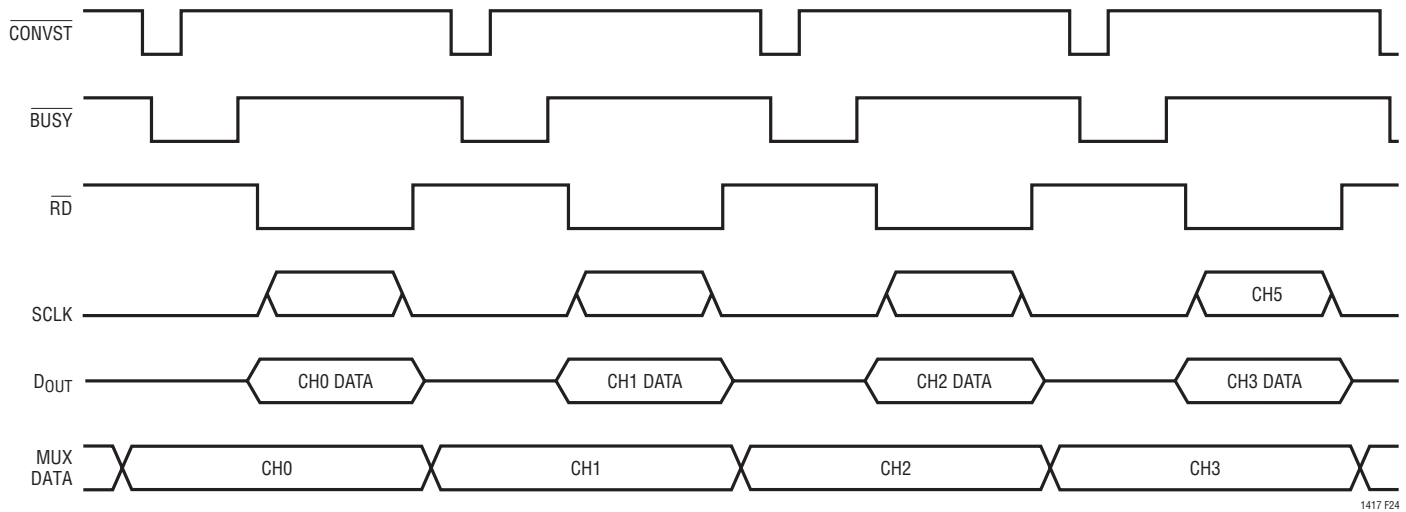
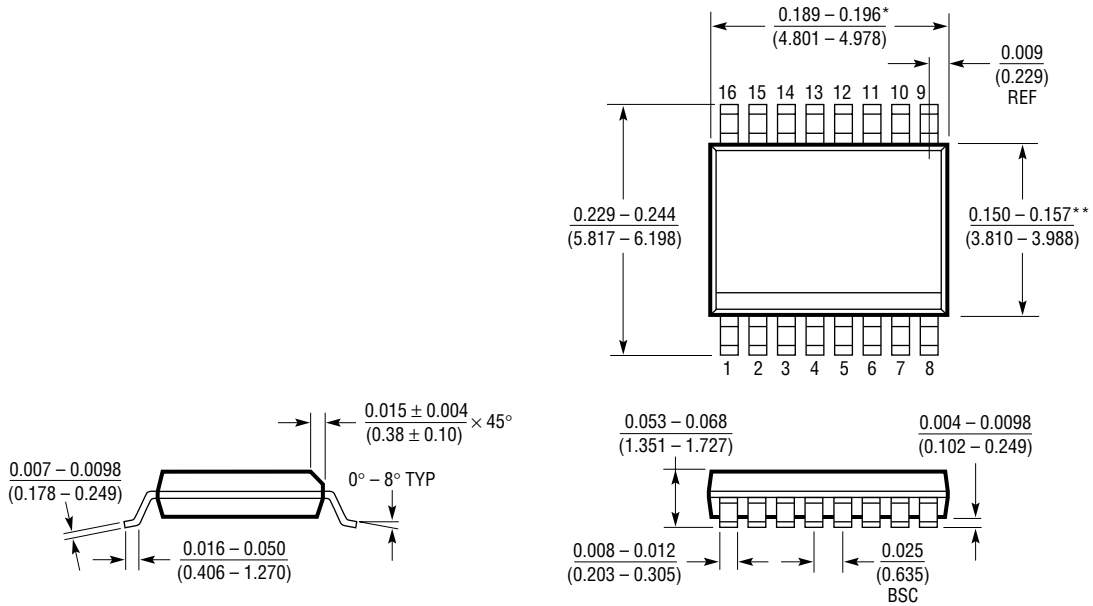

Figure 24. Using the Sample Program In Listing 2, the LTC1417, Combined with the DG408 8-Channel MUX, Has No Latency Between the Selected Input Voltage and Its Conversion Data as Shown In the Timing Relationship Above

PACKAGE DESCRIPTION

GN Package
16-Lead Plastic SSOP (Narrow 0.150)
 (LTC DWG # 05-08-1641)



- * DIMENSION DOES NOT INCLUDE MOLD FLASH. MOLD FLASH SHALL NOT EXCEED 0.006" (0.152mm) PER SIDE
- ** DIMENSION DOES NOT INCLUDE INTERLEAD FLASH. INTERLEAD FLASH SHALL NOT EXCEED 0.010" (0.254mm) PER SIDE

GN16 (SSOP) 0398

RELATED PARTS

PART NUMBER	DESCRIPTION	COMMENTS
ADCs		
LTC1274/LTC1277	Low Power, 12-Bit, 100ksps ADCs with Parallel Output	10mW Power Dissipation, Parallel/Byte Interface
LTC1401	Serial 3V, 12-Bit, 200ksps ADC in SO-8	15mW, Internal Reference and Low Power Shutdown Mode
LTC1404	Serial 12-Bit, 600ksps ADC in SO-8	5V or $\pm 5V$, Internal Reference and Shutdown
LTC1412	12-Bit, 3Msps Sampling ADC with Parallel Output	Best Dynamic Performance, SINAD = 72dB at Nyquist
LTC1415	Single 5V, 12-Bit, 1.25Msps ADC with Parallel Output	55mW Power Dissipation, 72dB SINAD
LTC1416	Low Power, 14-Bit, 400ksps ADC with Parallel Output	70mW Power Dissipation, 80.5dB SINAD
LTC1418	Low Power, 14-Bit, 200ksps ADC with Parallel and Serial I/O	True 14-Bit Linearity, 81.5dB, SINAD, 15mW Dissipation
LTC1419	Low Power, 14-Bit, 800ksps ADC with Parallel Output	True 14-Bit Linearity, 81.5dB SINAD, 150mW Dissipation
LTC1604	16-Bit, 333ksps Sampling ADC with Parallel Output	$\pm 2.5V$ Input, 90dB SINAD, 100dB THD
LTC1605	Single 5V, 16-Bit, 100ksps ADC with Parallel Output	Low Power, $\pm 10V$ Inputs, Parallel/Byte Interface
DACs		
LTC1595	Serial 16-Bit CMOS Multiplying DAC in SO-8	$\pm 1LSB$ Max INL/DNL, 1nV • sec Glitch, DAC8043 Upgrade
LTC1596	Serial 16-Bit CMOS Multiplying DAC	$\pm 1LSB$ Max INL/DNL, DAC8143/AD7543 Upgrade
LTC1650	Serial 16-Bit $\pm 5V$ Voltage Output DAC	Low Noise and Low Glitch Rail-to-Rail V_{OUT}
LTC1655	Serial 16-Bit Voltage Output DAC	Low Power, SO-8 with Internal Reference
LTC1658	Serial 14-Bit Voltage Output DAC	Low Power, 8-Lead MSOP Rail-to-Rail V_{OUT}
Reference		
LT1019-2.5	Precision Bandgap Reference	0.05% Max, 5ppm/ $^{\circ}C$ Max
LT1460-2.5	Micropower 3-Terminal Bandgap Reference	0.075% Max, 10ppm/ $^{\circ}C$ Max
LT1461-2.5	Ultraprecise Micropower Low Dropout Reference	0.04%, 3ppm/ $^{\circ}C$

Looking for pricing, stock, or lifecycle information?

Click below to explore more details on WIN SOURCE:

 [View LTC1417CGN#PBF on WIN SOURCE](#)

 [Linear Technology](#) Information

Optimize Your Supply Chain with WIN SOURCE Solutions

-  Global Sourcing Solution
-  Obsolete Management
-  Cost Control Management
-  Shortage Management
-  Alternative Solution
-  Excess Inventory Management