

Micropower, Regulated 5V Charge Pump DC/DC Converter

FEATURES

- Ultralow Power: Typical Operating $I_{CC} = 12\mu\text{A}$
- Short Circuit/Thermal Protection
- Regulated $5V \pm 4\%$ Output
- 2V to 5V Input Range
- No Inductors
- I_{CC} in Shutdown: $< 1\mu\text{A}$
- Output Current: 20mA ($V_{IN} > 2V$)
50mA ($V_{IN} > 3V$)
- Shutdown Disconnects Load from V_{IN}
- Internal Oscillator: 600kHz
- Compact Application Circuit (0.1 in^2)
- 8-Pin SO Package

APPLICATIONS

- 2-Cell to 5V Conversion
- Li-Ion Battery Backup Supplies
- Local 3V to 5V Conversion
- 5V Flash Memory Programmer
- Smart Card Readers

DESCRIPTION

The LTC[®]1516 is a micropower charge pump DC/DC converter that produces a regulated 5V output from a 2V to 5V supply. Extremely low supply current ($12\mu\text{A}$ typical with no load, $< 1\mu\text{A}$ in shutdown) and low external parts count (two $0.22\mu\text{F}$ flying capacitors and two $10\mu\text{F}$ capacitors at V_{IN} and V_{OUT}) make the LTC1516 ideally suited for small, light load battery-powered applications. Typical efficiency ($V_{IN} = 3V$) exceeds 70% with load currents between $50\mu\text{A}$ and 50mA. Modulating the SHDN pin keeps the typical efficiency above 70% with load currents all the way down to $10\mu\text{A}$.

The LTC1516 operates as either a doubler or a tripler depending on V_{IN} and output load conditions to improve overall efficiency. The part has thermal shutdown and can survive a continuous short from V_{OUT} to GND. In shutdown the load is disconnected from V_{IN} .

The LTC1516 is available in an 8-pin SO package in both commercial and industrial temperature grades.

 LTC and LT are registered trademarks of Linear Technology Corporation.

TYPICAL APPLICATION

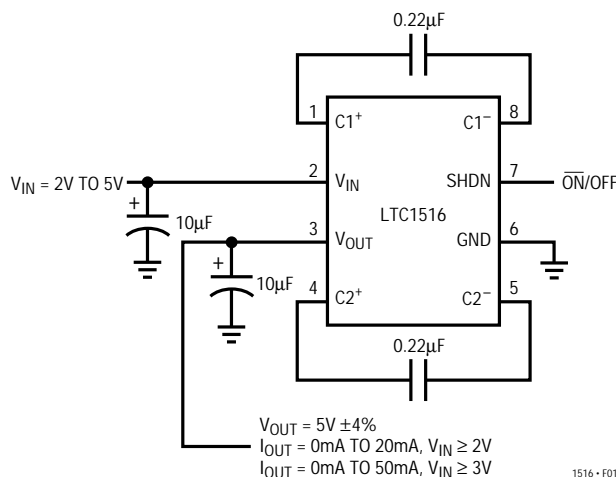
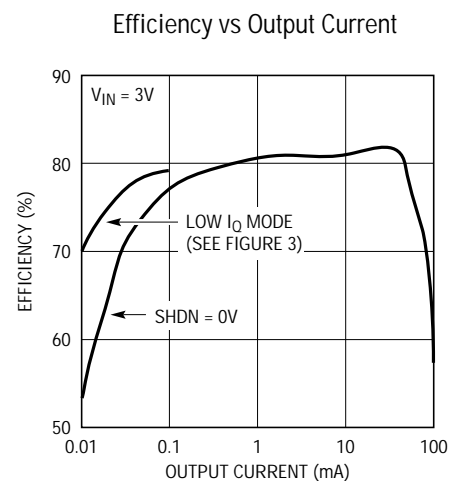

Figure 1. Regulated 5V Output from a 2V to 5V Input



ABSOLUTE MAXIMUM RATINGS

(Note 1)

V_{IN} to GND	-0.3V to 6V
V_{OUT} to GND	-0.3V to 6V
SHDN to GND	-0.3V to 6V
V_{OUT} Short-Circuit Duration	Indefinite
Operating Temperature Range	
Commercial	0°C to 70°C
Industrial	-40°C to 85°C
Storage Temperature Range	-65°C to 150°C
Lead Temperature (Soldering, 10 sec)	300°C

PACKAGE/ORDER INFORMATION

<p>S8 PACKAGE 8-LEAD PLASTIC SO $T_{JMAX} = 125^{\circ}\text{C}$, $\theta_{JA} = 150^{\circ}\text{C/W}$</p>	ORDER PART NUMBER
	LTC1516CS8 LTC1516IS8
	S8 PART MARKING
	1516 1516I

Consult factory for Military grade parts.

ELECTRICAL CHARACTERISTICS

$V_{IN} = 2\text{V to } 5\text{V}$, $C_1 = C_2 = 0.22\mu\text{F}$, $C_{IN} = C_{OUT} = 10\mu\text{F}$, T_{MIN} to T_{MAX} unless otherwise specified (Note 3).

SYMBOL	PARAMETER	CONDITIONS	MIN	TYP	MAX	UNITS	
V_{IN}	Input Voltage		●	2	5	V	
V_{OUT}	Output Voltage	$2\text{V} \leq V_{IN} \leq 5\text{V}$, $I_{OUT} \leq 20\text{mA}$	●	4.8	5.2	V	
		$3\text{V} \leq V_{IN} \leq 3.6\text{V}$, $I_{OUT} \leq 50\text{mA}$	●	4.8	5.2	V	
		$3.6\text{V} \leq V_{IN} \leq 5\text{V}$, $I_{OUT} \leq 50\text{mA}$, $T_A = 25^{\circ}\text{C}$ (Note 2)	●	4.8	5.2	V	
I_{CC}	Supply Current	$2\text{V} \leq V_{IN} \leq 5\text{V}$, $I_{OUT} = 0\text{mA}$, $\text{SHDN} = 0\text{V}$	●		12	20	μA
		$2\text{V} \leq V_{IN} \leq 5\text{V}$, $I_{OUT} = 0\text{mA}$, $\text{SHDN} = V_{IN}$	●		0.005	1	μA
	Output Ripple	Full Load			100	mV	
	Efficiency	$V_{IN} = 3\text{V}$, $I_{OUT} = 20\text{mA}$			82	%	
f_{OSC}	Switching Frequency	Full Load			600	kHz	
V_{IH}	SHDN Input Threshold		●	(0.7)(V_{IN})		V	
V_{IL}			●		0.4	V	
I_{IH}	SHDN Input Current	$V_{SHDN} = V_{IN}$	●	-1	1	μA	
I_{IL}		$V_{SHDN} = 0\text{V}$	●	-1	1	μA	
t_{ON}	V_{OUT} Turn-On Time	$V_{IN} = 3\text{V}$, $I_{OUT} = 0\text{mA}$ (Note 3)			500	μs	

The ● denotes specifications which apply over the full operating temperature range.

Note 1: Absolute Maximum Ratings are those values beyond which the life of the device may be impaired

Note 2: At input voltages > 3.6V and ambient temperatures > 70°C, continuous power dissipation must be derated to maintain junction temperatures below 125°C. Derate 6mW/°C above 70°C in SO-8.

Note 3: The LTC1516 is tested with the capacitors shown in Figure 1.

TYPICAL PERFORMANCE CHARACTERISTICS

Efficiency vs Input Voltage

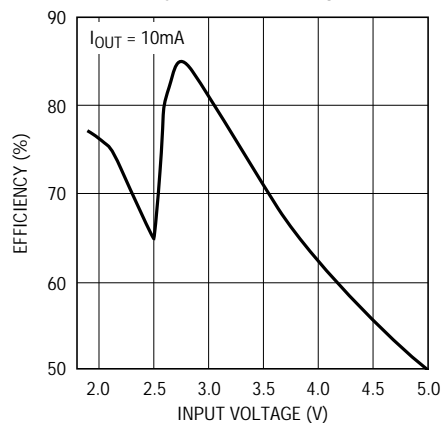

1516 • G01

Output Current vs Input Voltage

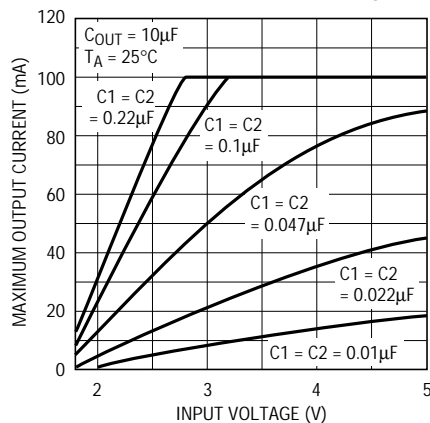

1516 • G02

No Load Supply Current vs Input Voltage

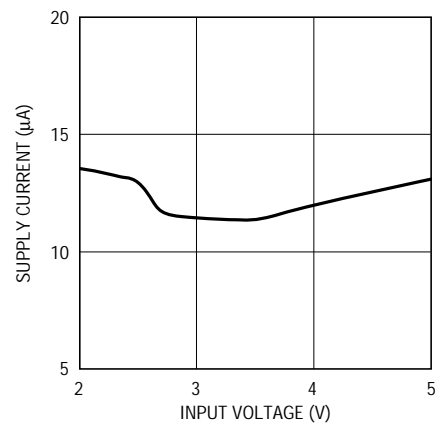

1516 • G03

Output Voltage vs Input Voltage

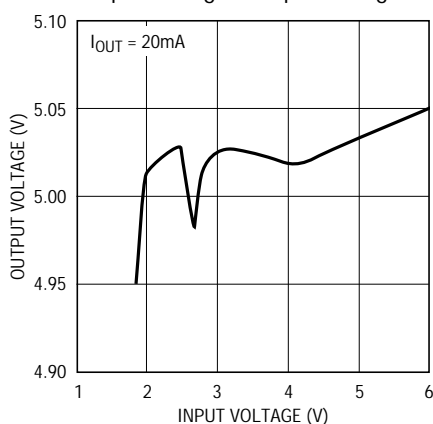

1516 • G04

Output Voltage vs Output Current

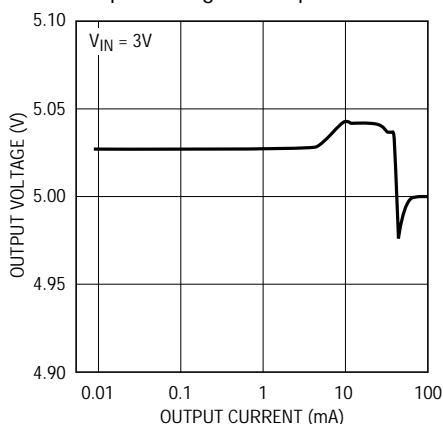

1516 • G05

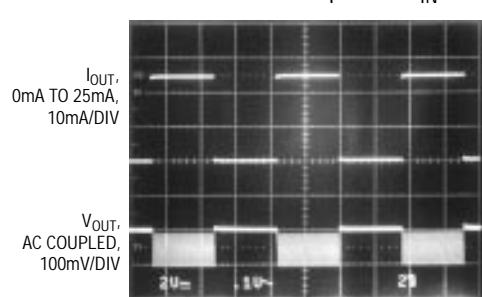
Load Transient Response, $V_{IN} = 3\text{V}$ 

1516 • G04

PIN FUNCTIONS

C1⁺ (Pin 1): Flying Capacitor 1, Positive Terminal. V_{IN} (Pin 2): Input Supply Voltage. V_{OUT} (Pin 3): 5V Output Voltage ($V_{OUT} = 0\text{V}$ in Shutdown).C2⁺ (Pin 4): Flying Capacitor 2, Positive Terminal.C2⁻ (Pin 5): Flying Capacitor 2, Negative Terminal.

GND (Pin 6): Ground.

SHDN (Pin 7): Active High CMOS Logic-Level Shutdown Input.

C1⁻ (Pin 8): Flying Capacitor 1, Negative Terminal.

BLOCK DIAGRAM

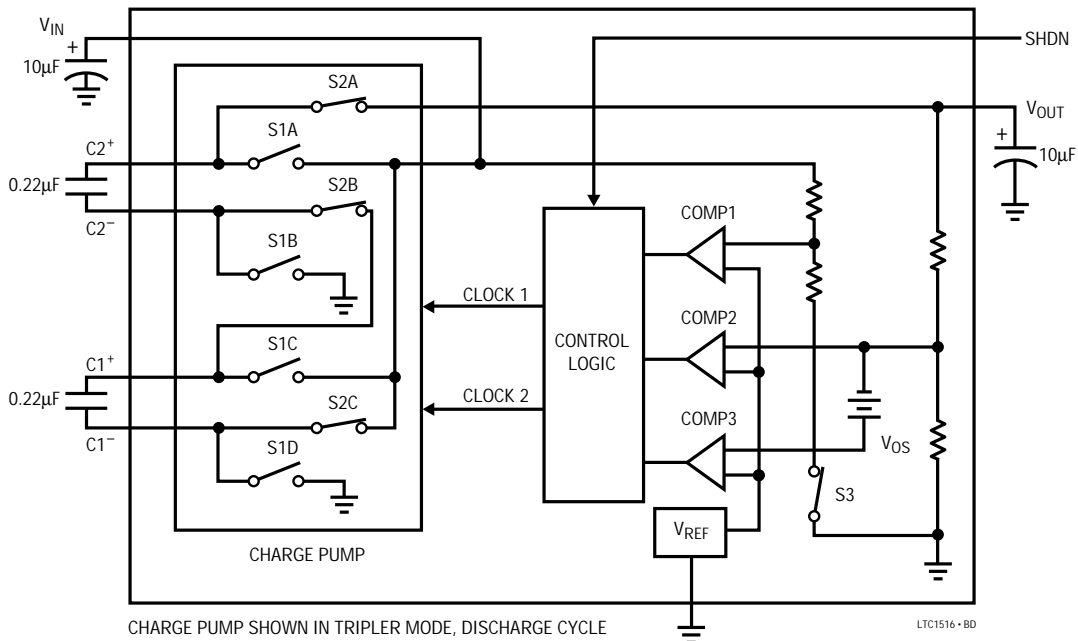

APPLICATIONS INFORMATION

Operation

The LTC1516 uses a switched capacitor charge pump to boost V_{IN} from 2V to 5V to a regulated $5V \pm 4\%$ output voltage. Regulation is achieved by sensing the output voltage through an internal resistor divider and enabling the charge pump when the output voltage droops below the lower trip point of COMP2. When the charge pump is enabled, a 2-phase, nonoverlapping clock controls the charge pump switches. Clock 1 closes the S1 switches which enable the flying capacitors, C1 and C2, to charge up to the V_{IN} voltage. Clock 2 closes the S2 switches which stack C1 and C2 in series with V_{IN} and connect the top plate of C2 to the output capacitor at V_{OUT} . This sequence of charging and discharging continues at a free-running frequency of 600kHz (typ) until the output has risen to the upper trip point of COMP2 and the charge pump is disabled. When the charge pump is disabled, the LTC1516 draws only $8\mu A$ (typ) from V_{IN} which provides high efficiency at low load conditions.

To achieve the highest efficiency over the entire V_{IN} range, the LTC1516 operates as either a doubler or a tripler

depending on V_{IN} and output load conditions. COMP1 and COMP2 determine whether the charge pump is in doubler mode or tripler mode. COMP1 forces the part into tripler mode if V_{IN} is $< 2.55V$, regardless of output load. When V_{IN} is $> 2.55V$, the part will be in doubler mode using only C2 as a flying capacitor. In doubler mode, if the output droops by 50mV under heavy loads, COMP3 will force the charge pump into tripler mode until V_{OUT} climbs above the upper trip point of COMP3. Under these V_{IN} and load conditions, the nominal V_{OUT} will be approximately 50mV lower than the no load nominal V_{OUT} . This method of sensing V_{IN} and output load results in efficiency greater than 80% with V_{IN} between 2.5V and 3V.

In shutdown mode, all circuitry is turned off and the part draws only leakage current ($< 1\mu A$) from the V_{IN} supply. V_{OUT} is also disconnected from V_{IN} . The SHDN pin is a CMOS input with a threshold of approximately $V_{IN}/2$; however, the SHDN pin can be driven by logic levels that exceed the V_{IN} voltage. The part enters shutdown mode when a logic high is applied to the SHDN pin. The SHDN pin cannot float; it must be driven with a logic high or low.

APPLICATIONS INFORMATION

Short-Circuit/Thermal Protection

During short-circuit conditions, the LTC1516 will draw between 200mA and 400mA from V_{IN} causing a rise in the junction temperature. On-chip thermal shutdown circuitry disables the charge pump once the junction temperature exceeds 135°C, and reenables the charge pump once the junction temperature falls back to 115°C. The LTC1516 will cycle in and out of thermal shutdown indefinitely without latchup or damage until the V_{OUT} short is removed.

Capacitor Selection

For best performance, it is recommended that low ESR capacitors be used for both C_{IN} and C_{OUT} to reduce noise and ripple. The C_{IN} and C_{OUT} capacitors should be either ceramic or tantalum and should be 10 μ F or greater. If the input source impedance is very low, C_{IN} may not be needed. Increasing the size of C_{OUT} to 22 μ F or greater will reduce output voltage ripple.

Ceramic or tantalum capacitors are recommended for the flying caps C1 and C2 with values in the range of 0.1 μ F to 1 μ F. Note that large value flying caps (>0.22 μ F) will increase output ripple unless C_{OUT} is also increased. For very low load applications, C1 and C2 may be reduced to 0.01 μ F to 0.047 μ F. This will reduce output ripple at the expense of efficiency and maximum output current.

Output Ripple

Normal LTC1516 operation produces voltage ripple on the V_{OUT} pin. Output voltage ripple is required for the LTC1516 to regulate. Low frequency ripple exists due to the hysteresis in the sense comparator and propagation delays in the charge pump enable/disable circuits. High frequency ripple is also present mainly due to ESR (Equivalent Series Resistance) in the output capacitor. Typical output ripple under maximum load is 100mV_{P-P} with a low ESR 10 μ F output capacitor.

The magnitude of the ripple voltage depends on several factors. High input voltages ($V_{IN} > 3.3V$) increase the output ripple since more charge is delivered to C_{OUT} per clock cycle. Large C1 and C2 flying capacitors (>0.22 μ F) also increase ripple for the same reason. Large output current load and/or a small output capacitor (<10 μ F) results in

higher ripple due to higher output voltage dV/dt. High ESR capacitors (ESR > 0.5 Ω) on the output pin cause high frequency voltage spikes on V_{OUT} with every clock cycle.

There are several ways to reduce the output voltage ripple. A larger C_{OUT} capacitor (22 μ F or greater) will reduce both the low and high frequency ripple due to the lower C_{OUT} charging and discharging dV/dt and the lower ESR typically found with higher value (larger case size) capacitors. A low ESR ceramic output capacitor will minimize the high frequency ripple, but will not reduce the low frequency ripple unless a high capacitance value is chosen. A reasonable compromise is to use a 10 μ F to 22 μ F tantalum capacitor in parallel with a 1 μ F to 3.3 μ F ceramic capacitor on V_{OUT} to reduce both the low and high frequency ripple. An RC filter may also be used to reduce high frequency voltage spikes (see Figure 2).

In low load or high V_{IN} applications, smaller values for C1 and C2 may be used to reduce output ripple. The smaller C1 and C2 flying capacitors (0.022 μ F to 0.1 μ F) deliver less charge per clock cycle to the output capacitor resulting in lower output ripple. However, the smaller value flying caps also reduce the maximum I_{OUT} capability as well as efficiency.

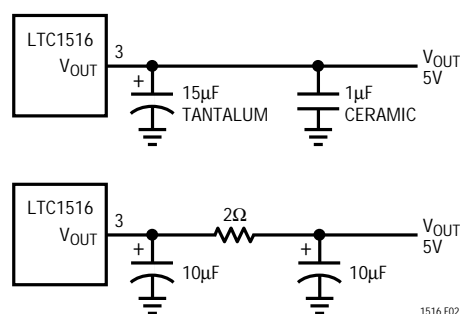

Figure 2. Output Ripple Reduction Techniques

Inrush Currents

During normal operation, V_{IN} will experience current transients in the 100mA to 200mA range whenever the charge pump is enabled. During start-up, these inrush currents may approach 500mA. For this reason, it is important to minimize the source resistance between the input supply and the V_{IN} pin to prevent start-up problems and large input voltage transients.

APPLICATIONS INFORMATION

Ultralow Quiescent Current ($I_Q < 5\mu A$) Regulated Supply

The LTC1516 contains an internal resistor divider (refer to Block Diagram) which draws only $1.5\mu A$ (typ) from V_{OUT} . During no-load conditions, the internal load causes a droop rate of only $150mV$ per second on V_{OUT} with $C_{OUT} = 10\mu F$. Applying a $5Hz$ to $100Hz$, 95% to 98% duty cycle signal to the SHDN pin ensures that the circuit of Figure 3 comes out of shutdown frequently enough to maintain regulation during no-load or low-load conditions. Since the part spends nearly all of its time in shutdown, the no-load quiescent current (see Figure 4a) is approximately equal to $(V_{OUT})(1.5\mu A)/(V_{IN})(Efficiency)$.

The LTC1516 must be out of shutdown for a minimum duration of $200\mu s$ to allow enough time to sense the output and keep it in regulation. As the V_{OUT} load current increases, the frequency with which the part is taken out of shutdown must also be increased to prevent V_{OUT} from drooping below $4.8V$ during the OFF phase (see Figure 4b). A $100Hz$ 98% duty cycle signal on the SHDN pin ensures proper regulation with load currents as high as $100\mu A$. When load current greater than $100\mu A$ is needed, the SHDN pin must be forced low as in normal operation. The typical no-load supply current for this circuit with $V_{IN} = 3V$ is only $3.2\mu A$.

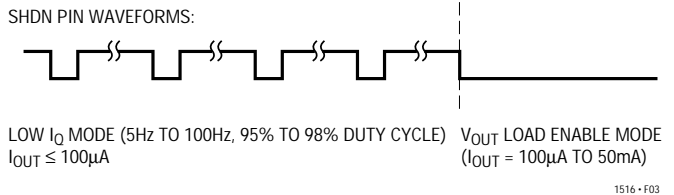
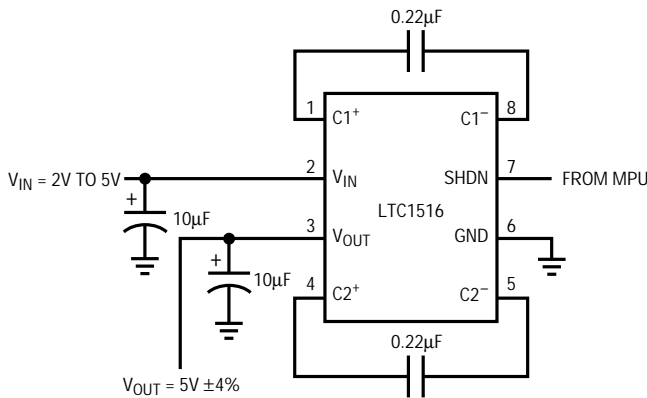

1516-F03

Figure 3. Ultralow Quiescent Current ($<5\mu A$) Regulated Supply

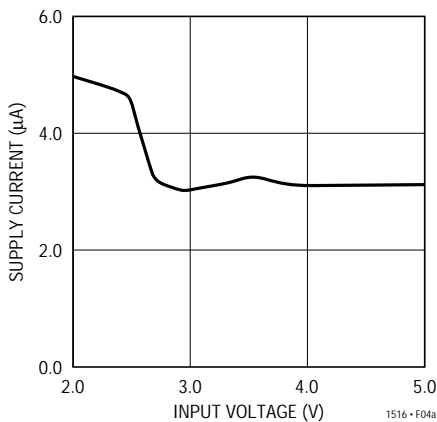

1516-F04a

Figure 4a. No Load I_{CC} vs Input Voltage for Circuit in Figure 3

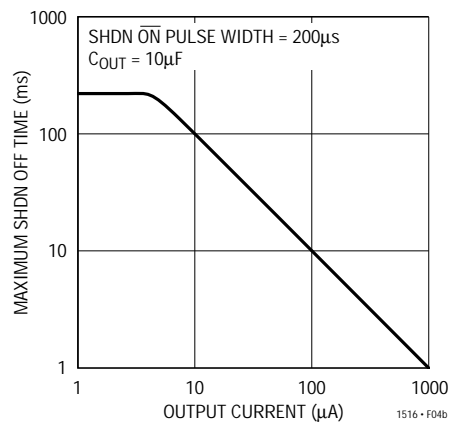

1516-F04b

Figure 4b. Maximum SHDN OFF Time vs Output Load Current for Ultralow I_Q Operation

APPLICATIONS INFORMATION

Paralleling Devices

Two or more LTC1516's may be connected in parallel to provide higher output currents. The V_{IN} , V_{OUT} , GND and SHDN pins may be tied together, but the C1 and C2 pins must be kept separate (see Figure 5). Separate C_{IN} and C_{OUT} capacitors may be required to reduce output noise and ripple if the paralleled devices cannot be kept close together. Otherwise, single C_{IN} and C_{OUT} capacitors may be used with each being 2× (or 3× if three parts are paralleled, etc.) in value.

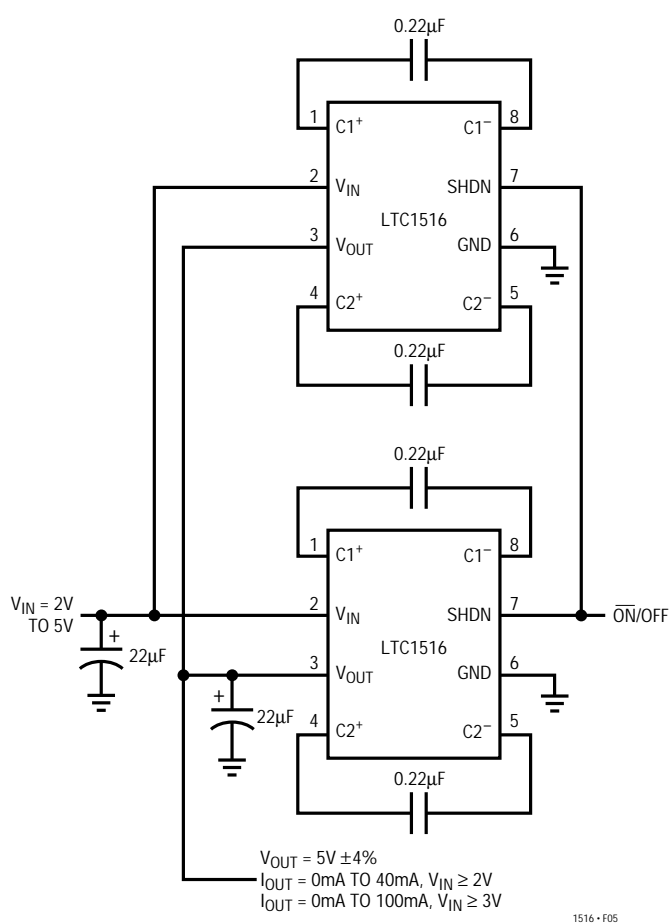

Figure 5. Paralleling Devices

General Layout Considerations

Due to the high switching frequency and high transient currents produced by the LTC1516, careful board layout is a must. A clean board layout using a ground plane and short connections to all capacitors will improve performance and ensure proper regulation under all conditions (refer to Figure 6).

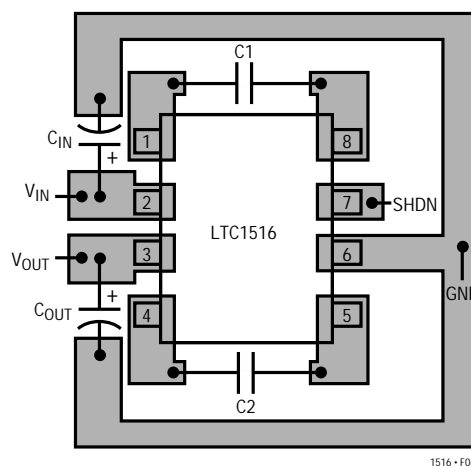
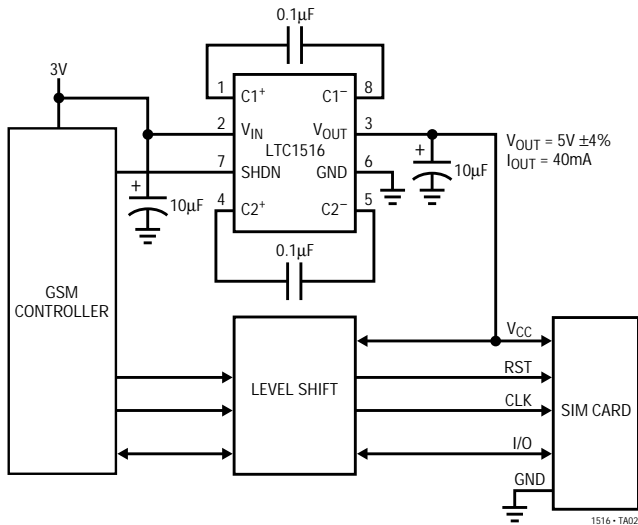

Figure 6. Suggested Component Placement for LTC1516

LTC1516

TYPICAL APPLICATIONS

Fault-Protected SIM Interface Supply for GSM Cellular Phones



Generating 5V and a Negative Supply

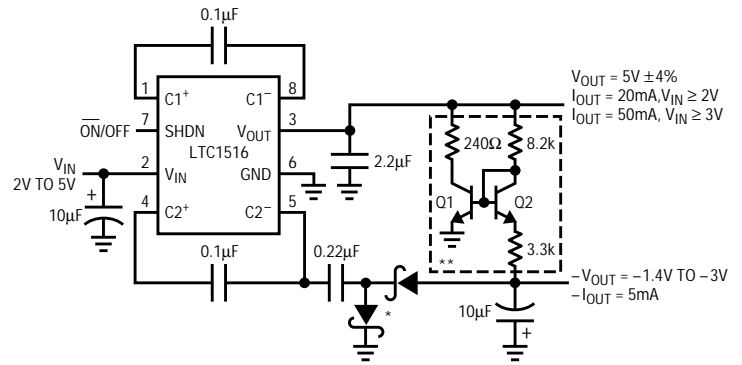

*CENTRAL SEMICONDUCTOR CMPSH-35 DUAL SCHOTTKY
 **OPTIONAL CIRCUITRY FOR MAINTAINING $-V_{OUT}$ AT LOW V_{OUT} LOADS
 Q1, Q2: 2N3904

1516-1A03

PACKAGE DESCRIPTION Dimensions in inches (millimeters) unless otherwise noted.

S8 Package
 8-Lead Plastic Small Outline (Narrow 0.150)
 (LTC DWG # 05-08-1610)

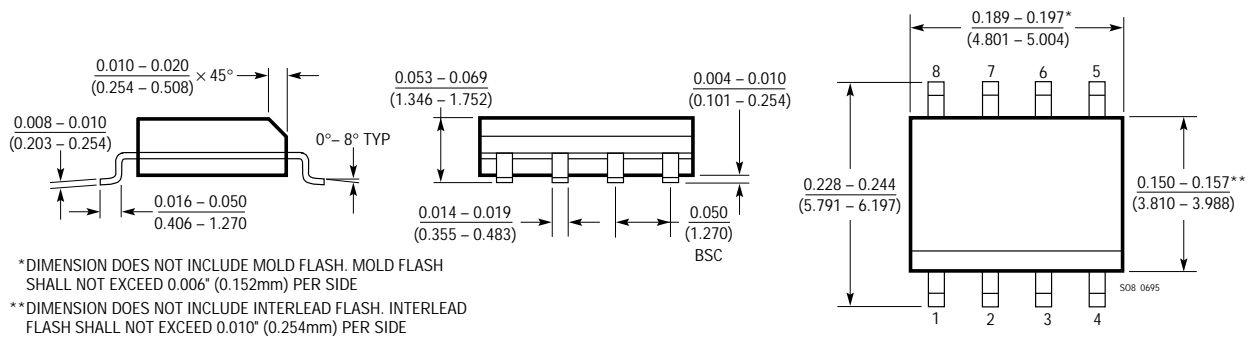

RELATED PARTS

PART NUMBER	DESCRIPTION	COMMENTS
LT [®] 1054	100mA Switched Capacitor Converter	Includes Reference and Amplifier for Regulation
LTC1144	20mA Switched Capacitor Converter for Up to 20V Inputs	Includes Micropower Shutdown (8µA)
LTC1261	Positive to Negative Regulated Switched Capacitor Converter	Low Noise (5mV) Output for Up to 10mA Loads
LTC1262	5V to 12V Regulated Switched Capacitor Converter	Up to 30mA at Regulated Output
LTC1550/51	Low Noise Switched Capacitor Regulated Converter	Provides -4.1V at 20mA with <1mV Ripple

Looking for pricing, stock, or lifecycle information?

Click below to explore more details on WIN SOURCE:

 [View LTC1516IS8#PBF](#) on WIN SOURCE

 [Linear Technology](#) Information

Optimize Your Supply Chain with WIN SOURCE Solutions

-  Global Sourcing Solution
-  Obsolete Management
-  Cost Control Management
-  Shortage Management
-  Alternative Solution
-  Excess Inventory Management