



**THE DATASHEET OF
LTC1517CS5-5#TRMPBF**



Micropower, Regulated 5V Charge Pump in a 5-Pin SOT-23 Package

FEATURES

- **Ultralow Power:** $I_{CC} = 6\mu\text{A}$ Typ
- **Short-Circuit/Thermal Protected**
- $5\text{V} \pm 4\%$ Regulated Output
- V_{IN} Range: 2.7V to 5V
- **Output Current:** 10mA ($V_{IN} \geq 2.7\text{V}$)
20mA ($V_{IN} \geq 3\text{V}$)
- No Inductors
- **Ultrasmall Application Circuit (0.045in²)**
- 800kHz Switching Frequency
- Available in 5-Pin SOT-23

APPLICATIONS

- Cellular Telephones
- Battery-Operated Equipment
- Local Power Supplies
- Handheld Instruments
- PCMCIA Supplies

DESCRIPTION

The LTC[®]1517-5 is a micropower charge pump DC/DC converter that produces a regulated 5V output. The input voltage range is 2.7V to 5V. Extremely low operating current (typically 6 μA with no load) and low external parts count (one 0.1 μF flying capacitor and two small bypass capacitors at V_{IN} and V_{OUT}) make the part ideally suited for small, light load battery-powered applications. The total printed circuit board area of the application circuit shown below is only 0.045in².

The part operates as a Burst Mode[™] switched-capacitor voltage doubler to produce a regulated output. The part has thermal shutdown capability and can survive a continuous short circuit from V_{OUT} to GND. The device is available in a 5-pin SOT-23 package.

LTC, LTC and LT are registered trademarks of Linear Technology Corporation. Burst Mode is a trademark of Linear Technology Corporation.

TYPICAL APPLICATION

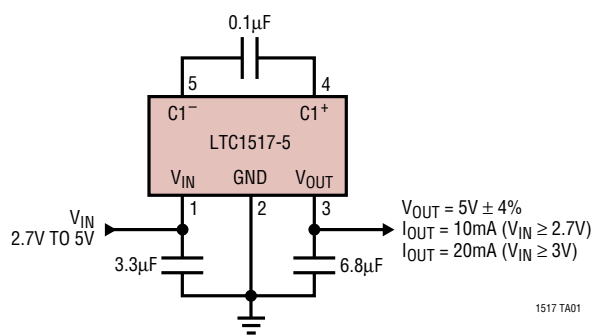

Typical Output Voltage vs Output Current

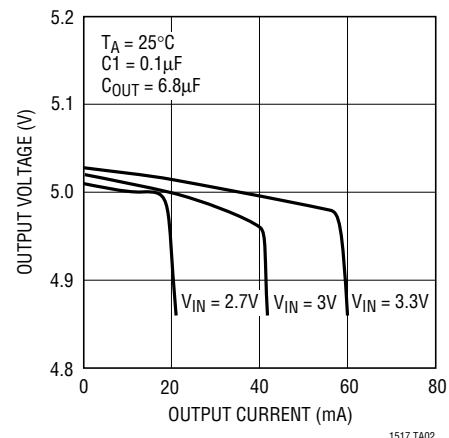

ABSOLUTE MAXIMUM RATINGS

(Note 1)

V_{IN} to GND	-0.3V to 6V
V_{OUT} to GND	-0.3V to 6V
V_{OUT} Short-Circuit Duration	Indefinite
Operating Temperature Range:	
Commercial	0°C to 70°C
Extended (Note 2)	-40°C to 85°C
Storage Temperature Range	-65°C to 150°C
Lead Temperature (Soldering, 10 sec)	300°C

PACKAGE/ORDER INFORMATION

<p>TOP VIEW</p> <p>V_{IN} 1 5 $C1^-$</p> <p>GND 2</p> <p>V_{OUT} 3 4 $C1^+$</p> <p>S5 PACKAGE 5-LEAD PLASTIC SOT-23 $T_{JMAX} = 125^{\circ}C$, $\theta_{JA} = 256^{\circ}C/W$</p>	ORDER PART NUMBER
	LTC1517CS5-5 LTC1517ES5-5
	S5 PART MARKING
	LTCX LTF

Consult factory for Industrial and Military grade parts and for -3 and -3.3 version availability.

ELECTRICAL CHARACTERISTICS

$V_{IN} = 2.7V$ to $5V$, $C1 = 0.1\mu F$, $C_{IN} = 3.3\mu F$, $C_{OUT} = 6.8\mu F$, T_{MIN} to T_{MAX} , unless otherwise noted.

SYMBOL	PARAMETER	CONDITIONS	MIN	TYP	MAX	UNITS
V_{IN}	Operating Input Voltage		2.7		5	V
V_{OUT}	Output Voltage	$2.7V \leq V_{IN} \leq 5V$, $I_{OUT} \leq 10mA$	4.8	5.0	5.2	V
		$3V \leq V_{IN} \leq 5V$, $I_{OUT} \leq 20mA$	4.8	5.0	5.2	V
I_{CC}	Input Supply Current	$2.7V \leq V_{IN} \leq 5V$, $I_{OUT} = 0$		6	15	μA
	V_{OUT} Ripple	$V_{IN} = 3V$, $I_{OUT} = 20mA$, $C_{OUT} = 6.8\mu F$		75		mV _{P-P}
f_{OSC}	Oscillator Frequency			800		kHz
t_{ON}	V_{OUT} Turn-On Time	$V_{IN} = 3V$		1		ms

The ● denotes specifications that apply over the full operating temperature range.

Note 1: Absolute Maximum Ratings are those values beyond which the life of the device may be impaired.

Note 2: Extended grade parts are 100% tested at $T_A = 25^{\circ}C$. Performance at $-40^{\circ}C$ and $85^{\circ}C$ is assured by design, characterization and correlation with statistical process controls.

TYPICAL PERFORMANCE CHARACTERISTICS

Output Voltage vs Input Voltage

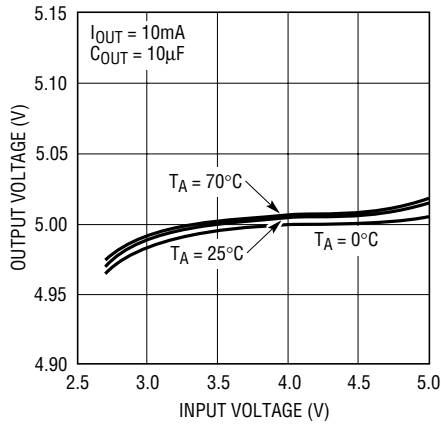

1517-5 G01

Efficiency vs Input Voltage

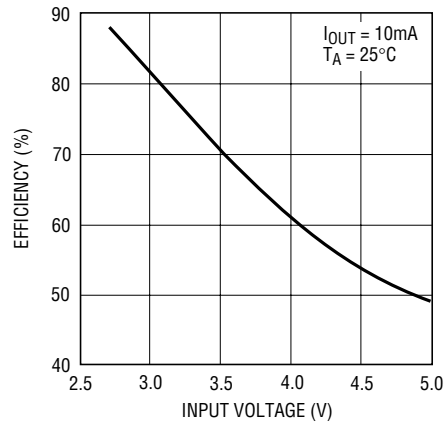

1517-5 G02

Output Ripple vs Input Voltage

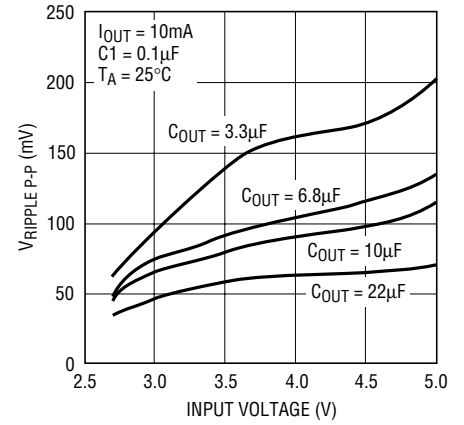

1517-5 G03

No Load Input Current vs Input Voltage

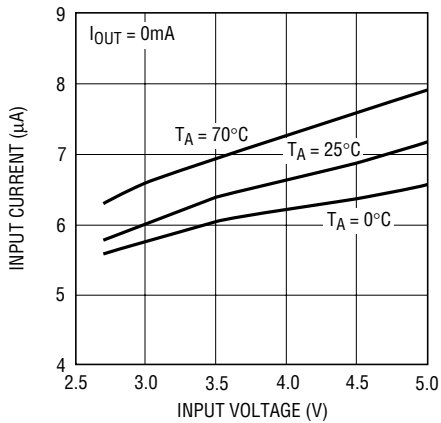

1517-5 G04

Efficiency vs Output Current

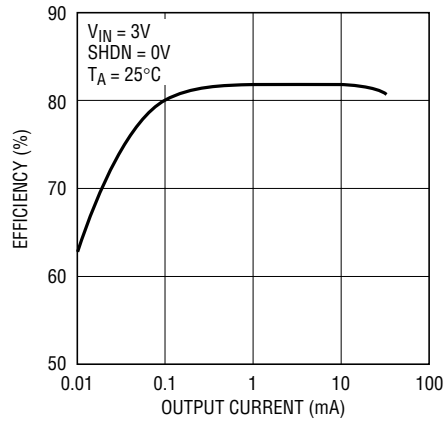

1517-5 G05

Load Transient Response

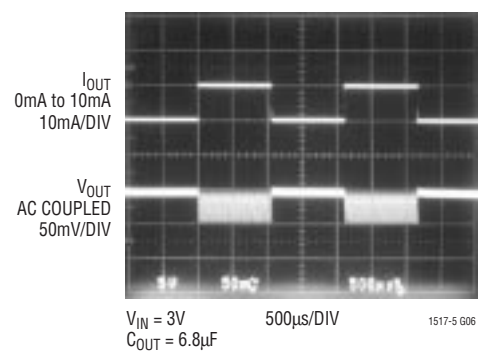

1517-5 G06

PIN FUNCTIONS

V_{IN} (Pin 1): Charge Pump Input Voltage. May be between 2.7V and 5V. V_{IN} should be bypassed with a $\geq 3.3\mu\text{F}$ low ESR capacitor as close as possible to the pin for best performance.

GND (Pin 2): Ground. Should be tied to a ground plane for best performance.

V_{OUT} (Pin 3): Regulated Output Voltage. V_{OUT} should be bypassed with a $\geq 3.3\mu\text{F}$ low ESR capacitor as close as possible to the pin for best performance.

C1⁺ (Pin 4): Charge Pump Flying Capacitor Positive Terminal.

C1⁻ (Pin 5): Charge Pump Flying Capacitor Negative Terminal.

SIMPLIFIED BLOCK DIAGRAM

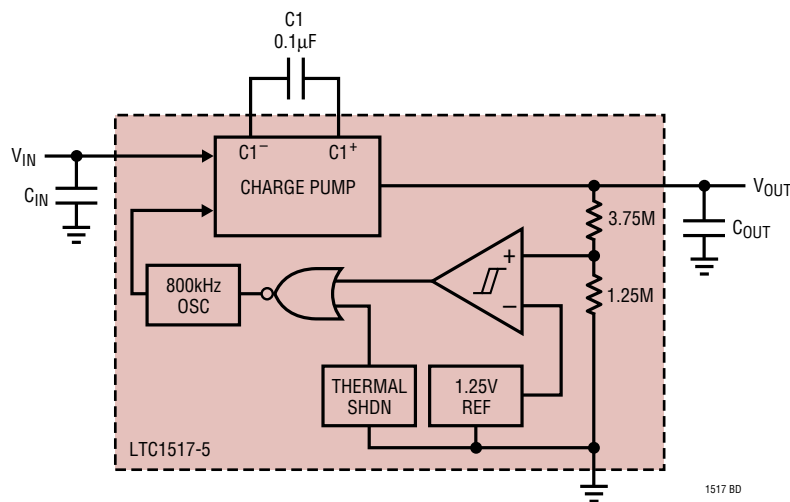

APPLICATIONS INFORMATION

Operation

The LTC1517-5 uses a switched-capacitor charge pump to boost V_{IN} to a $5V \pm 4\%$ regulated output. The part achieves regulation by sensing the output voltage through an internal resistor divider and enabling the charge pump when the divided output droops below the comparator's lower trip point (set by V_{REF}). When the charge pump is enabled, a 2-phase nonoverlapping clock controls the internal charge pump switches. Flying capacitor C1 is charged to V_{IN} on phase one of the clock. On phase two of the clock, C1 is stacked in series with V_{IN} and connected to V_{OUT} through an internal switch. This sequence of charging and discharging the flying capacitor occurs at a free running frequency of 800kHz (typ) and continues until the divided output voltage reaches the upper trip point of the comparator. Once the output is back in regulation, the charge pump is disabled. This method of bursting the charge pump on and off enables the LTC1517-5 to achieve high efficiency at extremely low output loads.

Capacitor Selection

For best performance, it is recommended that low ESR capacitors be used for both C_{IN} and C_{OUT} to reduce noise and ripple. The C_{IN} and C_{OUT} capacitors should be either ceramic or tantalum and should be $3.3\mu F$ or greater. Ceramic capacitors will provide the smallest size and lowest ESR for a given capacitance. If the input source impedance is very low ($< 0.5\Omega$), C_{IN} may not be needed. Ceramic capacitors are recommended for the flying capacitor C1 with values of $0.1\mu F$ or $0.22\mu F$. Smaller value flying capacitors may be used in low I_{OUT} applications.

Output Ripple

Normal LTC1517-5 operation produces voltage ripple on the V_{OUT} pin. Output voltage ripple is required for the part to regulate. Low frequency ripple exists due to the hysteresis in the sense comparator and propagation delays in the charge pump enable/disable circuits. High frequency ripple is also present mainly from the ESR (equivalent series resistance) in the output capacitor. Typical output ripple with $V_{IN}=3V$ under maximum load is 100mV peak-to-peak with a low ESR ($< 0.5\Omega$) $3.3\mu F$ output capacitor (minimum recommended C_{OUT}). For applications requiring V_{IN} to exceed 3.3V or for applications requiring $< 100mV$ of peak-to-peak ripple, a $6.8\mu F$ to $10\mu F$ C_{OUT} capacitor is recommended. Slight further decreases in output ripple can be achieved by using C_{OUT} capacitors larger than $10\mu F$.

Short-Circuit/Thermal Protection

During short-circuit conditions, the LTC1517-5 will draw between 50mA and 200mA from V_{IN} , causing a rise in junction temperature. On-chip thermal shutdown circuitry disables the charge pump once the junction temperature exceeds approximately $160^\circ C$. The charge pump is reenabled once the junction temperature drops to approximately $145^\circ C$. The LTC1517-5 will cycle in and out of thermal shutdown indefinitely without latchup or damage until the V_{OUT} short is removed.

TYPICAL APPLICATIONS

Low Noise Boosted 5V Supply

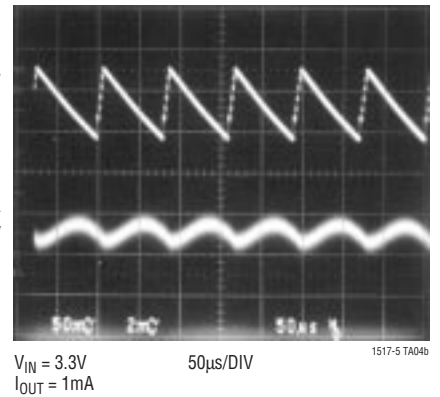
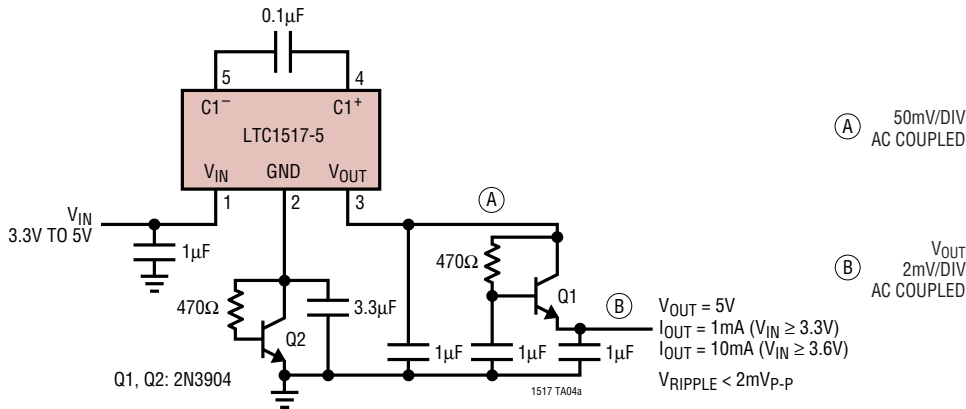

Generating 5V and a Negative Supply

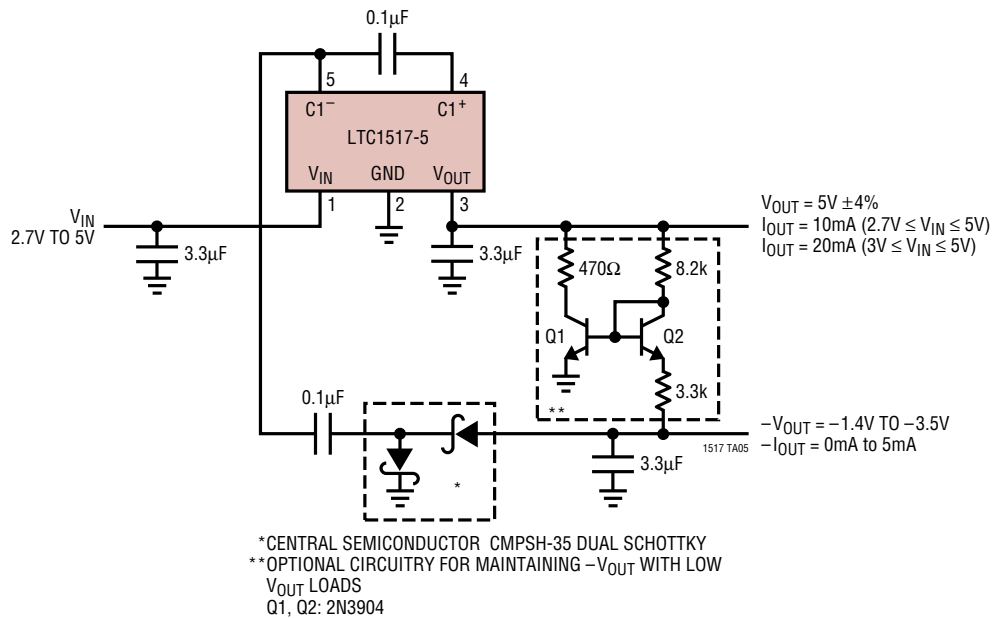

PACKAGE DESCRIPTION

Dimensions in inches (millimeters) unless otherwise noted.

S5 Package 5-Lead Plastic SOT-23 (LTC DWG # 05-08-1633)

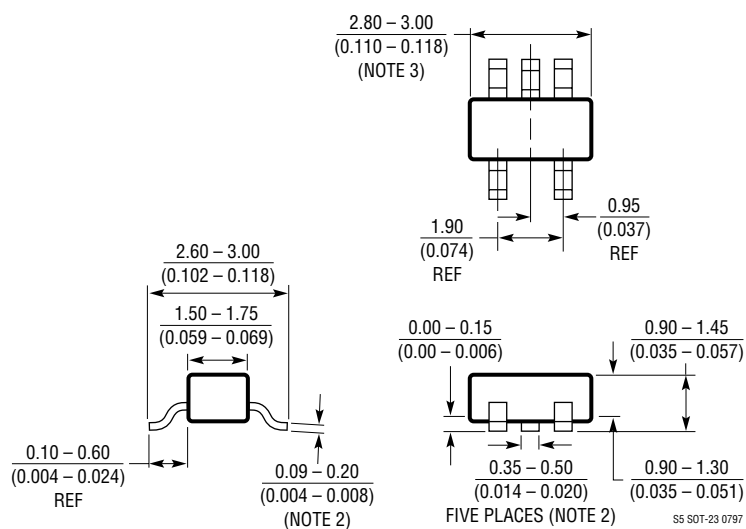

NOTE:

1. DIMENSIONS ARE IN MILLIMETERS
2. DIMENSIONS ARE INCLUSIVE OF PLATING
3. DIMENSIONS ARE EXCLUSIVE OF MOLD FLASH AND METAL BURR
4. MOLD FLASH SHALL NOT EXCEED 0.254mm
5. PACKAGE EIAJ REFERENCE IS SC-74A (EIAJ)

TYPICAL APPLICATION

3.3V to 1.9V, 6A Power Supply

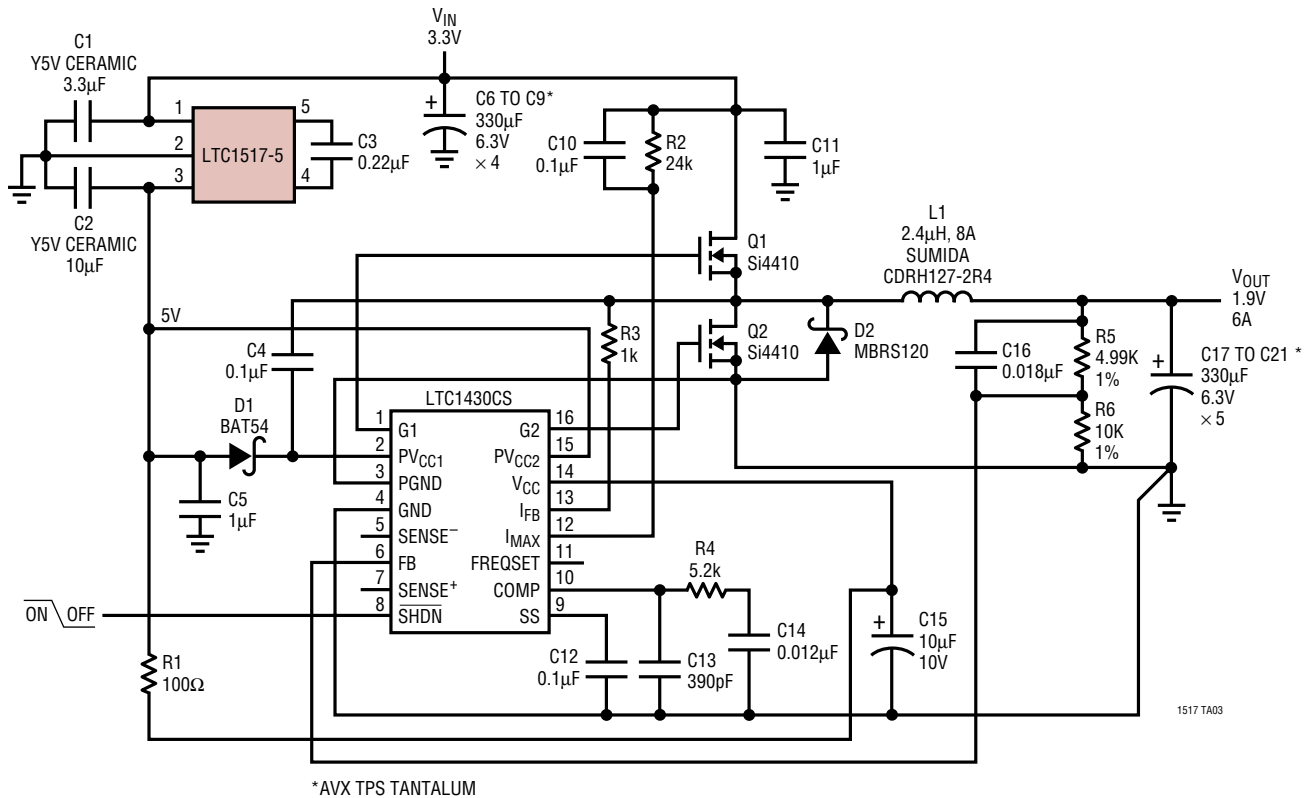



RELATED PARTS

PART NUMBER	DESCRIPTION	COMMENTS
LTC1514-X	Step-Up/Step-Down Switched-Capacitor DC/DC Converter with Low Battery Comparator	3.3V or 5V Output Up to 50mA
LTC1515 Series	Step-Up/Step-Down Switched-Capacitor DC/DC Converter with Reset	Fixed or Adjustable Output Up to 50mA
LTC1516	Micropower Regulated 5V Charge Pump DC/DC Converter	20mA for $V_{IN} \geq 2V$, 50mA for $V_{IN} \geq 3V$
LTC1522	Micropower Regulated 5V Charge Pump DC/DC Converter	Same as LTC1517-5 with Shutdown, Available in MSOP

Looking for pricing, stock, or lifecycle information?

Click below to explore more details on WIN SOURCE:

-  [View LTC1517CS5-5#TRMPBF on WIN SOURCE](#)
-  [Linear Technology Information](#)

Optimize Your Supply Chain with WIN SOURCE Solutions

-  Global Sourcing Solution
-  Obsolete Management
-  Cost Control Management
-  Shortage Management
-  Alternative Solution
-  Excess Inventory Management