



**THE DATASHEET OF  
LTC1517ES5-3.3#TRMPBF**



# Micropower, Regulated 3.3V Charge Pump in a 5-Pin SOT-23 Package

## FEATURES

- **Ultralow Power:**  $I_{CC} = 6\mu\text{A Typ}$
- **Short-Circuit/Thermal Protected**
- $3.3\text{V} \pm 4\%$  Regulated Output
- $V_{IN}$  Range: 2V to 4.4V
- **Output Current:**  $8\text{mA}$  ( $V_{IN} \geq 2\text{V}$ )  
 $15\text{mA}$  ( $V_{IN} \geq 2.5\text{V}$ )
- No Inductors
- **Ultrasmall Application Circuit** ( $0.045\text{in}^2$ )
- 700kHz Switching Frequency
- Available in 5-Pin SOT-23

## APPLICATIONS

- Cellular Telephones
- Battery-Operated Equipment
- Local Power Supplies
- Handheld Instruments
- PCMCIA Supplies

## DESCRIPTION

The LTC<sup>®</sup>1517-3.3 is a micropower charge pump DC/DC converter that produces a regulated 3.3V output. The input voltage range is 2V to 4.4V, allowing a single cell lithium battery to produce a regulated 3.3V output over the entire life of the battery. Extremely low operating current (typically  $6\mu\text{A}$  with no load) and low external parts count (one  $0.1\mu\text{F}$  flying capacitor and two small bypass capacitors at  $V_{IN}$  and  $V_{OUT}$ ) make the part ideally suited for small, light load battery-powered applications. The total printed circuit board area of the application circuit shown below is only  $0.045\text{in}^2$ .

The part operates as a Burst Mode<sup>™</sup> switched-capacitor voltage doubler to produce a regulated output. The part has thermal shutdown capability and can survive a continuous short circuit from  $V_{OUT}$  to GND. The device is available in a 5-pin SOT-23 package.

LT, LTC and LT are registered trademarks of Linear Technology Corporation. Burst Mode is a trademark of Linear Technology Corporation.

## TYPICAL APPLICATION

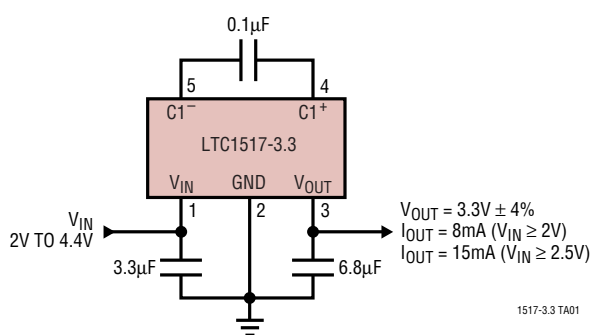

Typical Output Voltage  
vs Output Current

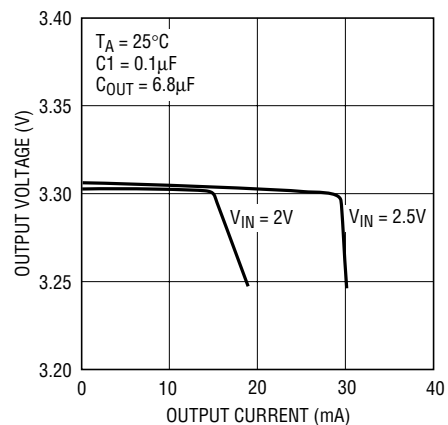

## ABSOLUTE MAXIMUM RATINGS

(Note 1)

$V_{IN}$ to GND .....	-0.3V to 6V
$V_{OUT}$ to GND .....	-0.3V to 6V
$V_{OUT}$ Short-Circuit Duration .....	Indefinite
Operating Temperature Range:	
Commercial .....	0°C to 70°C
Extended .....	-40°C to 85°C
Storage Temperature Range .....	-65°C to 150°C
Lead Temperature (Soldering, 10 sec) .....	300°C

## PACKAGE/ORDER INFORMATION

	ORDER PART NUMBER
	LTC1517CS5-3.3 LTC1517ES5-3.3
	S5 PART MARKING
	LTEF LTTE

Consult factory for Industrial and Military grade parts.

## ELECTRICAL CHARACTERISTICS

$V_{IN} = 2V$  to  $4.4V$ ,  $C_1 = 0.1\mu F$ ,  $C_{IN} = 3.3\mu F$ ,  $C_{OUT} = 6.8\mu F$ ,  $T_{MIN}$  to  $T_{MAX}$ , unless otherwise noted.

SYMBOL	PARAMETER	CONDITIONS	MIN	TYP	MAX	UNITS	
$V_{IN}$	Operating Input Voltage		●	2.0	4.4	V	
$V_{OUT}$	Output Voltage	$2V \leq V_{IN} \leq 4.4V$ , $I_{OUT} \leq 8mA$	●	3.17	3.3	3.43	V
		$2.5V \leq V_{IN} \leq 4.4V$ , $I_{OUT} \leq 15mA$	●	3.17	3.3	3.43	V
$I_{CC}$	Input Supply Current	$2V \leq V_{IN} \leq 4.4V$ , $I_{OUT} = 0$	●		6	15	$\mu A$
	$V_{OUT}$ Ripple	$V_{IN} = 2.5V$ , $I_{OUT} = 15mA$ , $C_{OUT} = 6.8\mu F$			50		mV <sub>p-p</sub>
$f_{OSC}$	Oscillator Frequency			700		kHz	
$t_{ON}$	$V_{OUT}$ Turn-On Time	$V_{IN} = 2.5V$			1		ms
$I_{SC}$	Output Short-Circuit Current	$V_{IN} = 3V$			60		mA

The ● denotes specifications that apply over the full operating temperature range.

**Note 1:** Absolute Maximum Ratings are those values beyond which the life of the device may be impaired.

**Note 2:** Extended grade parts are 100% tested at  $T_A = 25^\circ C$ . Performance at  $-40^\circ C$  and  $85^\circ C$  is assured by design, characterization and correlation with statistical process controls.

# TYPICAL PERFORMANCE CHARACTERISTICS

**Output Voltage vs Input Voltage**

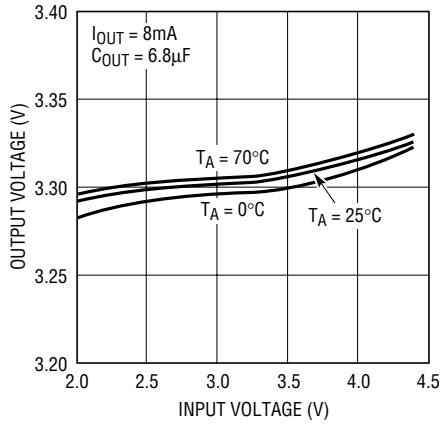

1517 G01

**Efficiency vs Input Voltage**

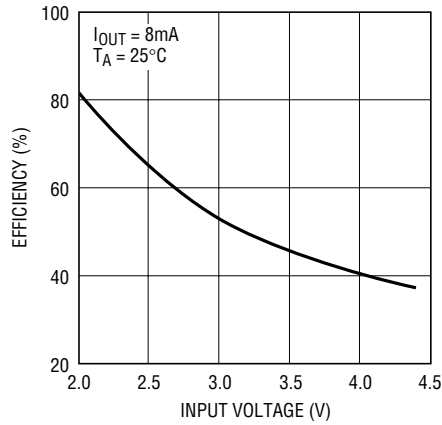

1517 G02

**Output Ripple vs Input Voltage**

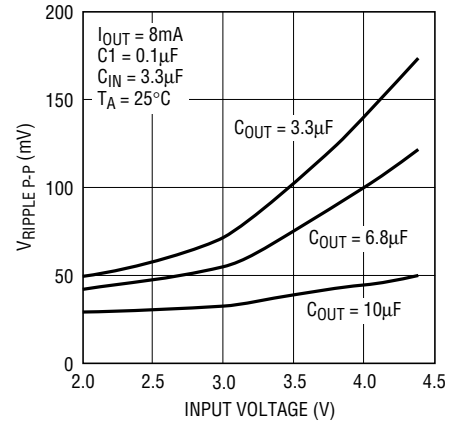

1517 G03

**No Load Input Current vs Input Voltage**

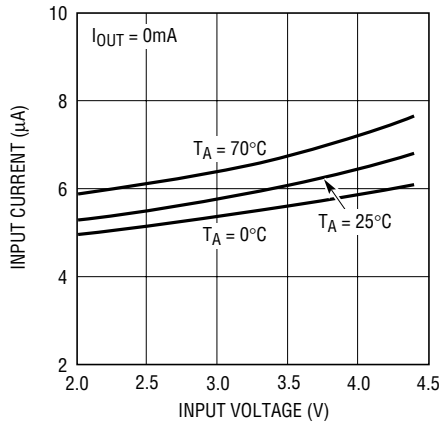

1517 G04

**Typical Efficiency vs Output Current**

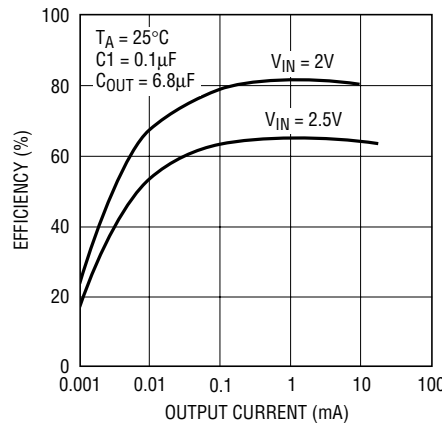

1517 TA02

**Load Transient Response**

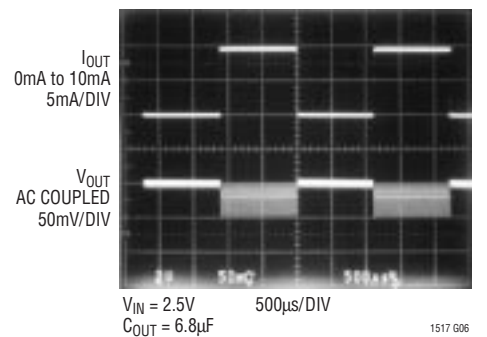

1517 G06

**Typical Output Current vs Temperature**

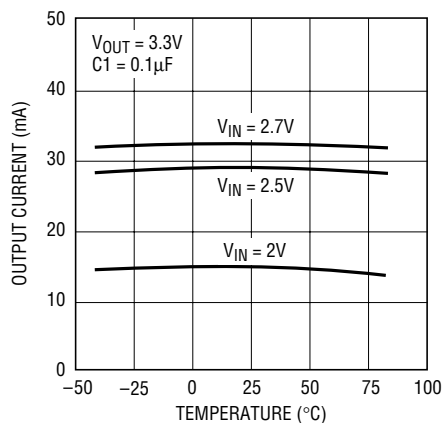

1517 G09

**V<sub>OUT</sub> Short-Circuit Current vs Input Voltage**

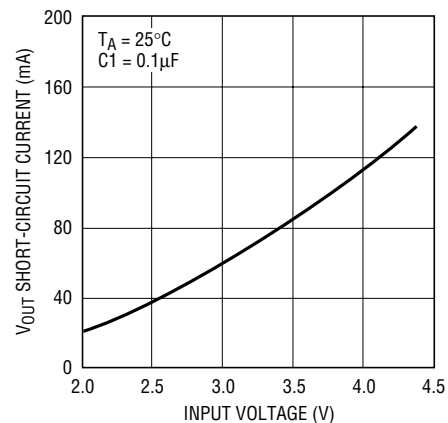

1517 G10

## TYPICAL PERFORMANCE CHARACTERISTICS

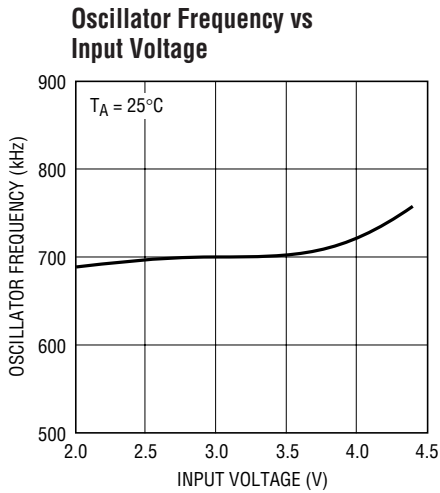

1517 G07

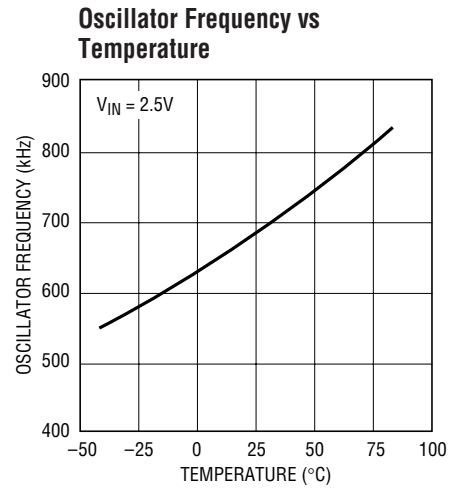

1517 G08

## PIN FUNCTIONS

**V<sub>IN</sub> (Pin 1):** Charge Pump Input Voltage. May be between 2V and 4.4V. V<sub>IN</sub> should be bypassed with a ≥3.3μF low ESR capacitor as close as possible to the pin for best performance.

**GND (Pin 2):** Ground. Should be tied to a ground plane for best performance.

**V<sub>OUT</sub> (Pin 3):** Regulated Output Voltage. V<sub>OUT</sub> should be bypassed with a ≥3.3μF low ESR capacitor as close as possible to the pin for best performance.

**C1<sup>+</sup> (Pin 4):** Charge Pump Flying Capacitor Positive Terminal.

**C1<sup>-</sup> (Pin 5):** Charge Pump Flying Capacitor Negative Terminal.

## SIMPLIFIED BLOCK DIAGRAM

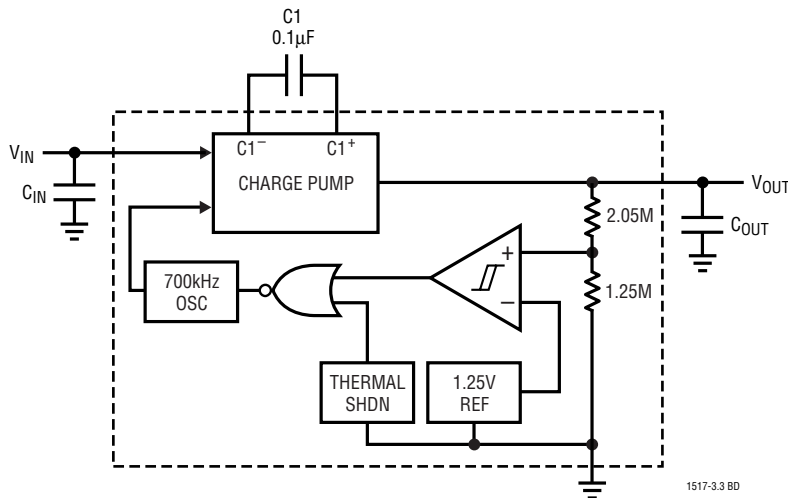

1517-3.3 BD

## APPLICATIONS INFORMATION

### Operation

The LTC1517-3.3 uses a switched-capacitor charge pump to boost  $V_{IN}$  to a  $3.3V \pm 4\%$  regulated output. The part achieves regulation by sensing the output voltage through an internal resistor divider and enabling the charge pump when the divided output droops below the comparator's lower trip point (set by  $V_{REF}$ ). When the charge pump is enabled, a 2-phase nonoverlapping clock controls the internal charge pump switches. Flying capacitor C1 is charged to  $V_{IN}$  on phase one of the clock. On phase two of the clock, C1 is stacked in series with  $V_{IN}$  and connected to  $V_{OUT}$  through an internal switch. This sequence of charging and discharging the flying capacitor occurs at a free running frequency of 700kHz (typ) and continues until the divided output voltage reaches the upper trip point of the comparator. Once the output is back in regulation, the charge pump is disabled. This method of bursting the charge pump on and off enables the LTC1517-3.3 to achieve high efficiency at extremely low output loads.

### Capacitor Selection

For best performance, it is recommended that low ESR capacitors be used for both  $C_{IN}$  and  $C_{OUT}$  to reduce noise and ripple. The  $C_{IN}$  and  $C_{OUT}$  capacitors should be either ceramic or tantalum and should be  $3.3\mu F$  or greater. Ceramic capacitors will provide the smallest size for a given capacitance. If the input source impedance is very low ( $< 0.5\Omega$ ),  $C_{IN}$  may not be needed. Ceramic capacitors are recommended for the flying capacitor C1 with values of  $0.1\mu F$  or  $0.22\mu F$ . Smaller value flying capacitors may be used in low  $I_{OUT}$  applications.

### Output Ripple

Normal LTC1517-3.3 operation produces voltage ripple on the  $V_{OUT}$  pin. Output voltage ripple is required for the parts to regulate. Low frequency ripple exists due to the hysteresis in the sense comparator and propagation delays in the charge pump enable/disable circuits. High frequency ripple is also present mainly from the ESR (equivalent series resistance) in the output capacitor. Typical output ripple with  $V_{IN} = 2.5V$  under maximum load is 75mV peak-to-peak with a low ESR  $3.3\mu F$  output capacitor (minimum recommended  $C_{OUT}$ ). For applications requiring  $V_{IN}$  to exceed 3.3V or for applications requiring less than 75mV of peak-to-peak ripple, a  $6.8\mu F$  to  $10\mu F$   $C_{OUT}$  capacitor is recommended. Slight further decreases in output ripple can be achieved by using  $C_{OUT}$  capacitors larger than  $10\mu F$ .

### Short-Circuit/Thermal Protection

During short-circuit conditions, the LTC1517-3.3 will draw between 20mA and 150mA from  $V_{IN}$ , causing a rise in junction temperature. On-chip thermal shutdown circuitry disables the charge pump once the junction temperature exceeds approximately  $160^{\circ}C$ . The charge pump is reenabled once the junction temperature drops to approximately  $145^{\circ}C$ . The LTC1517-3.3 will cycle in and out of thermal shutdown indefinitely without latchup or damage until the  $V_{OUT}$  short is removed.

## TYPICAL APPLICATIONS

### Low Noise Boosted 3.3V Supply



(A) 50mV/DIV  
AC COUPLED

(B)  $V_{OUT}$   
2mV/DIV  
AC COUPLED

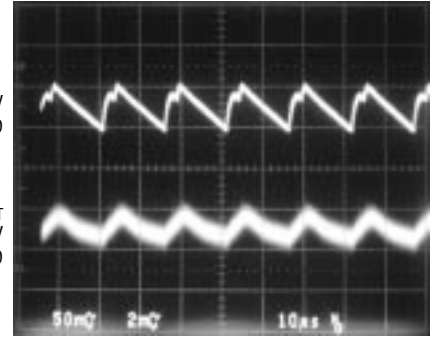

$V_{IN} = 2.7V$   
 $I_{OUT} = 5mA$

10μs/DIV

1517 TA04b

### Generating 3.3V and a Negative Supply

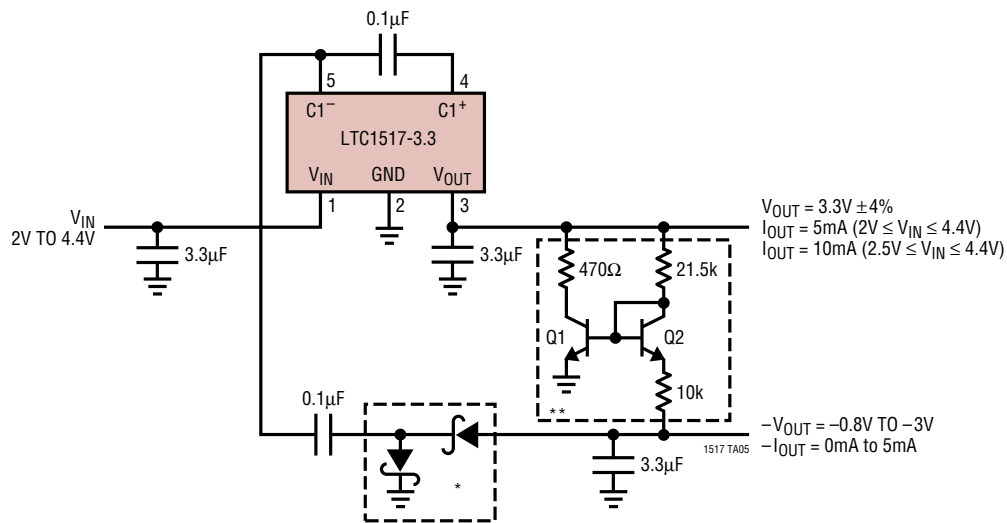

\*CENTRAL SEMICONDUCTOR CMPSH-35 DUAL SCHOTTKY  
 \*\*OPTIONAL CIRCUITRY FOR MAINTAINING  $-V_{OUT}$  WITH LOW  
 $V_{OUT}$  LOADS  
 Q1, Q2: 2N3904

**PACKAGE DESCRIPTION**

Dimensions in inches (millimeters) unless otherwise noted.

**S5 Package**  
**5-Lead Plastic SOT-23**  
 (LTC DWG # 05-08-1633)

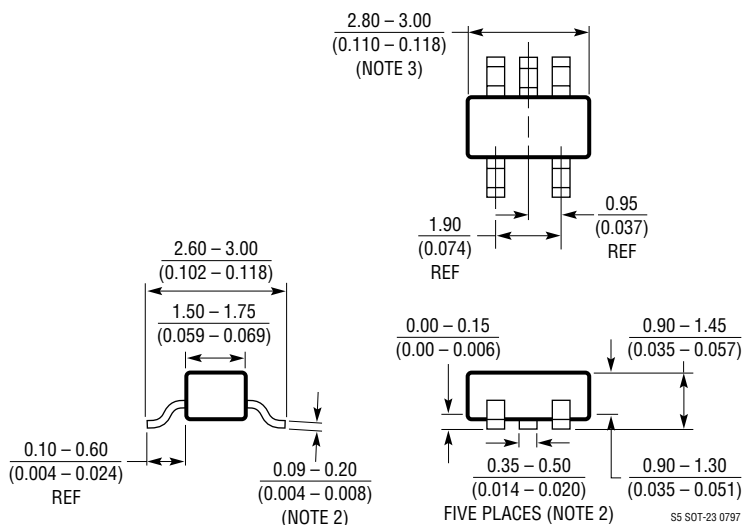

## NOTE:

1. DIMENSIONS ARE IN MILLIMETERS
2. DIMENSIONS ARE INCLUSIVE OF PLATING
3. DIMENSIONS ARE EXCLUSIVE OF MOLD FLASH AND METAL BURR
4. MOLD FLASH SHALL NOT EXCEED 0.254mm
5. PACKAGE EIAJ REFERENCE IS SC-74A (EIAJ)

# TYPICAL APPLICATION

Low Power Battery Backup Supply with Autoswitchover and No Reverse Current

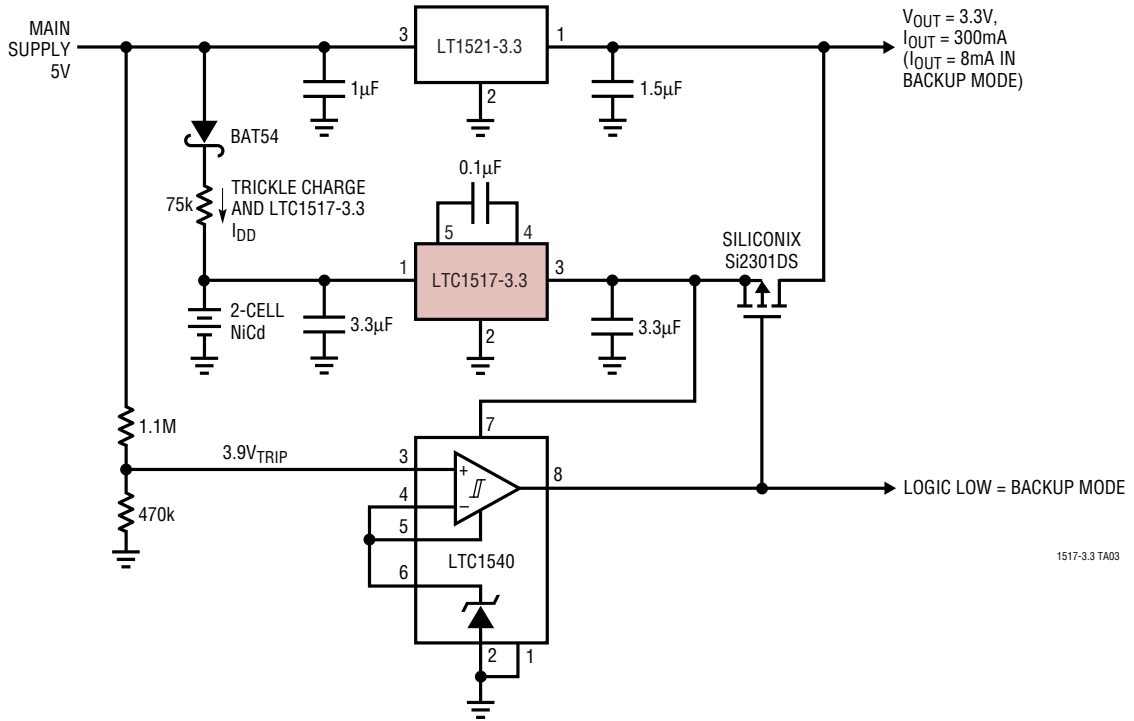

1517-3.3 TA03

## RELATED PARTS

PART NUMBER	DESCRIPTION	COMMENTS
LTC1514-X	Step-Up/Step-Down Switched-Capacitor DC/DC Converter with Low Battery Comparator	3.3V or 5V Output up to 50mA
LTC1515	Step-Up/Step-Down Switched-Capacitor DC/DC Converter with POR	Fixed or Adjustable Output up to 50mA
LTC1516	Micropower Regulated 5V Charge Pump DC/DC Converter	20mA for V <sub>IN</sub> ≥ 2V, 50mA for V <sub>IN</sub> ≥ 3V
LTC1517-5	Micropower Regulated 5V Charge Pump in a 5-Pin SOT-23 Package	I <sub>OUT</sub> up to 20mA
LTC1522	Micropower Regulated 5V Charge Pump DC/DC Converter	Same as LTC1517-5 with Shutdown

## Looking for pricing, stock, or lifecycle information?

Click below to explore more details on WIN SOURCE:

 [View LTC1517ES5-3.3#TRMPBF on WIN SOURCE](#)

 [Linear Technology](#) Information

## Optimize Your Supply Chain with WIN SOURCE Solutions

-  Global Sourcing Solution
-  Obsolete Management
-  Cost Control Management
-  Shortage Management
-  Alternative Solution
-  Excess Inventory Management