



**THE DATASHEET OF
LTC1622CMS8#PBF**



Low Input Voltage Current Mode Step-Down DC/DC Controller

FEATURES

- High Efficiency
- Constant Frequency 550kHz Operation
- V_{IN} Range: 2V to 10V
- Multiampere Output Currents
- OPTI-LOOP™ Compensation Minimizes C_{OUT}
- Selectable, Burst Mode Operation
- Low Dropout Operation: 100% Duty Cycle
- Synchronizable up to 750kHz
- Current Mode Operation for Excellent Line and Load Transient Response
- Low Quiescent Current: 350 μ A
- Shutdown Mode Draws Only 15 μ A Supply Current
- $\pm 1.9\%$ Reference Accuracy
- Available in 8-Lead MSOP

APPLICATIONS

- 1- or 2-Cell Li-Ion Powered Applications
- Cellular Telephones
- Wireless Modems
- Portable Computers
- Distributed 3.3V, 2.5V or 1.8V Power Systems
- Scanners
- Battery-Powered Equipment

LT, LTC and LT are registered trademarks of Linear Technology Corporation. Burst Mode and OPTI-LOOP are a trademarks of Linear Technology Corporation.

DESCRIPTION

The LTC[®]1622 is a constant frequency current mode step-down DC/DC controller providing excellent AC and DC load and line regulation. The device incorporates an accurate undervoltage feature that shuts the LTC1622 down when the input voltage falls below 2V.

The LTC1622 boasts a $\pm 1.9\%$ output voltage accuracy and consumes only 350 μ A of quiescent current. For applications where efficiency is a prime consideration and the load current varies from light to heavy, the LTC1622 can be configured for Burst Mode™ operation. Burst Mode operation enhances low current efficiency and extends battery run time. Burst Mode operation is inhibited during synchronization or when the SYNC/MODE pin is pulled low to reduce noise and possible RF interference.

High constant operating frequency of 550kHz allows the use of a small inductor. The device can also be synchronized up to 750kHz for special applications. The high frequency operation and the available 8-lead MSOP package create a high performance solution in an extremely small amount of PCB area.

To further maximize the life of the battery source, the P-channel MOSFET is turned on continuously in dropout (100% duty cycle). In shutdown, the device draws a mere 15 μ A.

TYPICAL APPLICATION

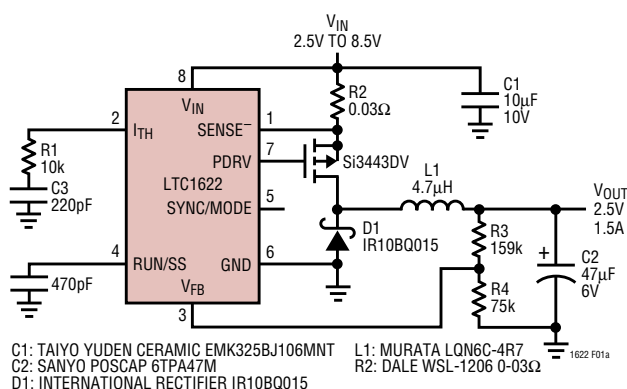
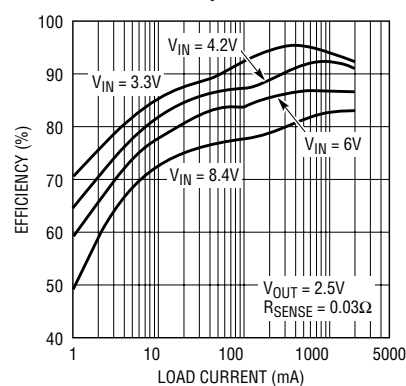

Figure 1. High Efficiency Step-Down Converter

Efficiency vs Load Current with Burst Mode Operation Enabled



ABSOLUTE MAXIMUM RATINGS (Note 1)

Input Supply Voltage (V_{IN})	-0.3V to 10V	Operating Temperature Range	
RUN/SS Voltage	-0.3V to 2.4V	Commercial	0°C to 70°C
SYNC/MODE Voltage	-0.3V to V_{IN}	Industrial	-45°C to 85°C
SENSE ⁻ Voltage	2.4V to V_{IN}	Junction Temperature (Note 2)	125°C
PDRV Peak Output Current (< 10 μ s)	1A	Lead Temperature (Soldering, 10 sec)	300°C
Storage Ambient Temperature Range	-65°C to 150°C		

PACKAGE/ORDER INFORMATION

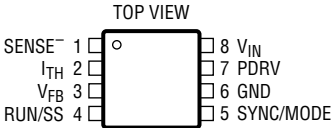
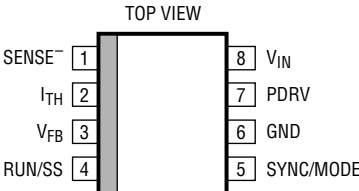
 <p>TOP VIEW</p> <p>SENSE⁻ 1, I_{TH} 2, V_{FB} 3, RUN/SS 4, 8 V_{IN}, 7 PDRV, 6 GND, 5 SYNC/MODE</p> <p>MS8 PACKAGE 8-LEAD PLASTIC MSOP T_{JMAX} = 125°C, θ_{JA} = 250°C/W</p>	ORDER PART NUMBER	 <p>TOP VIEW</p> <p>SENSE⁻ 1, I_{TH} 2, V_{FB} 3, RUN/SS 4, 8 V_{IN}, 7 PDRV, 6 GND, 5 SYNC/MODE</p> <p>S8 PACKAGE 8-LEAD PLASTIC SO T_{JMAX} = 125°C, θ_{JA} = 150°C/W</p>	ORDER PART NUMBER
	LTC1622CMS8		LTC1622CS8 LTC1622IS8
	MS8 PART MARKING		S8 PART MARKING
	LTDB		1622 1622I

Consult factory for Military grade parts.

ELECTRICAL CHARACTERISTICS

The ● denotes specifications which apply over the full operating temperature range, otherwise specifications are at $T_A = 25^\circ\text{C}$. $V_{IN} = 4.2\text{V}$

SYMBOL	PARAMETER	CONDITIONS	MIN	TYP	MAX	UNITS
I_{VFB}	Feedback Current	(Note 3) $V_{FB} = 0.8\text{V}$		10	70	nA
V_{FB}	Regulated Feedback Voltage	(Note 3) Commercial Grade (Note 3) Industrial Grade	● 0.785 ● 0.780	0.8	0.815 0.820	V
V_{OVL}	Output Overvoltage Lockout	Referenced to Nominal V_{OUT}	4	16	25	%
ΔV_{OSENSE}	Reference Voltage Line Regulation	$V_{IN} = 4.2\text{V}$ to 8.5V (Note 3)		0.04	0.08	%/V
$V_{LOADREG}$	Output Voltage Load Regulation	Measured in Servo Loop; $V_{ITH} = 0.2\text{V}$ to 0.625V Measured in Servo Loop; $V_{ITH} = 0.9\text{V}$ to 0.625V		0.3 -0.3	0.5 -0.5	%
I_S	Input DC Supply Current	(Note 4)				
	Burst Mode Inhibited	$V_{IN} = 2.3\text{V}$		450		μA
	Sleep Mode	$V_{ITH} = 0\text{V}$, $V_{SYNC/MODE} = 2.4\text{V}$		350	400	μA
	Shutdown	$V_{RUN/SS} = 0\text{V}$		15	30	μA
	Shutdown	$V_{RUN/SS} = 0\text{V}$, $V_{IN} = V_{UVLO} - 0.1\text{V}$		4	10	μA
$V_{RUN/SS}$	RUN/SS Threshold	Commercial Grade Industrial Grade	● 0.4 ● 0.3	0.7	0.9 1.0	V
$I_{RUN/SS}$	Soft-Start Current Source	$V_{RUN/SS} = 0\text{V}$	1	2.5	5	μA
f_{OSC}	Oscillator Frequency	$V_{FB} = 0.8\text{V}$ $V_{FB} = 0\text{V}$	475 75	550 110	625 140	kHz
$V_{SYNC/MODE}$	SYNC/MODE Threshold	$V_{SYNC/MODE}$ Ramping Down		1	1.5	V
V_{UVLO}	Undervoltage Lockout	V_{IN} Ramping Down V_{IN} Ramping Up	● 1.55	1.92 1.97	2.3 2.36	V

ELECTRICAL CHARACTERISTICS The ● denotes specifications which apply over the full operating temperature range, otherwise specifications are at $T_A = 25^\circ\text{C}$. $V_{IN} = 4.2\text{V}$

SYMBOL	PARAMETER	CONDITIONS	MIN	TYP	MAX	UNITS
PDRV t_r	Gate Drive Rise Time	$C_{LOAD} = 3000\text{pF}$		80	140	ns
PDRV t_f	Gate Drive Fall Time	$C_{LOAD} = 3000\text{pF}$		100	140	ns
$\Delta V_{SENSE(MAX)}$	Maximum Current Sense Voltage		● 80	110	140	mV

Note 1: Absolute Maximum Ratings are those values beyond which the life of a device may be impaired.

Note 2: T_J is calculated from the ambient temperature T_A and power dissipation P_D according to the following formula:

LTC1622CS8; $T_J = T_A + (P_D \cdot 150^\circ\text{C/W})$,
 LTC1622CMS8; $T_J = T_A + (P_D \cdot 250^\circ\text{C/W})$

Note 3: The LTC1622 is tested in a feedback loop that servos V_{FB} to the feedback point for the error amplifier ($V_{I_{TH}} = 0.8\text{V}$).

Note 4: Dynamic supply current is higher due to the gate charge being delivered at the switching frequency.

TYPICAL PERFORMANCE CHARACTERISTICS

Shutdown Current vs Supply Voltage

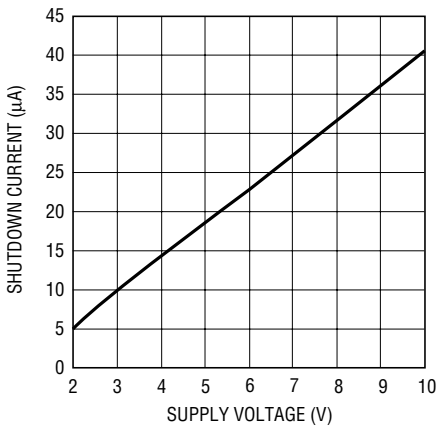

1622 G01

RUN/SS Current vs Supply Voltage

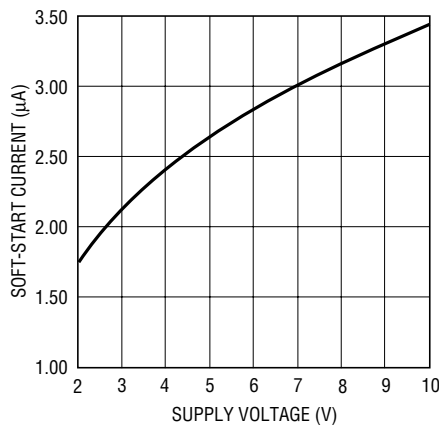

1622 G02

Maximum Current Sense Voltage vs Duty Cycle

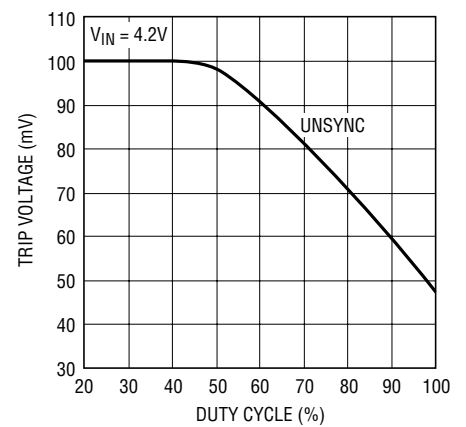

1622 G03

Normalized Oscillator Frequency vs Temperature

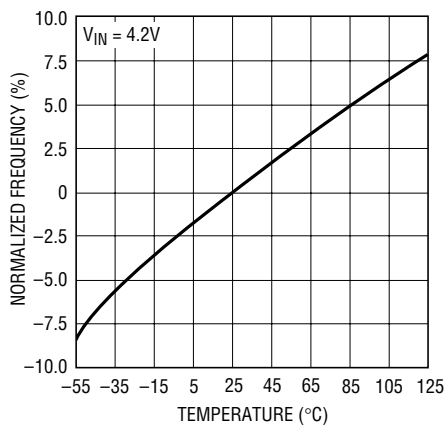

1622 G04

Reference Voltage vs Temperature

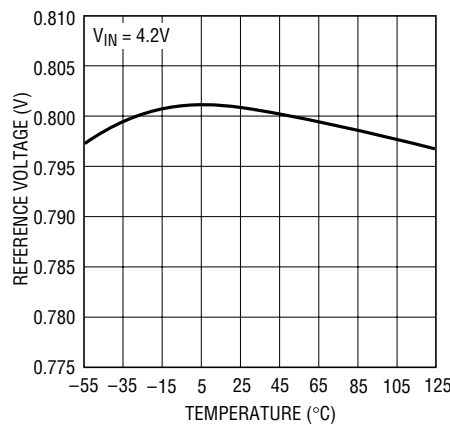

1622 G05

Undervoltage Lockout Voltage vs Temperature

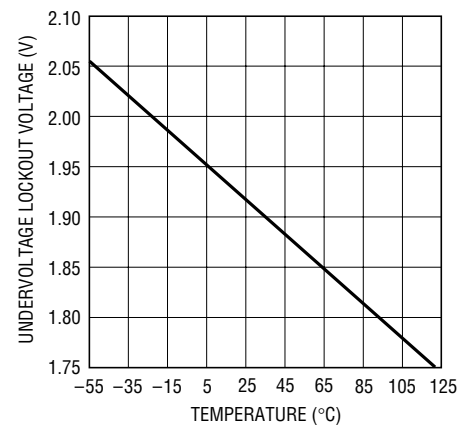

1622 G06

TYPICAL PERFORMANCE CHARACTERISTICS

Efficiency vs Load Current for Figure 1 with Burst Mode Operation Defeated

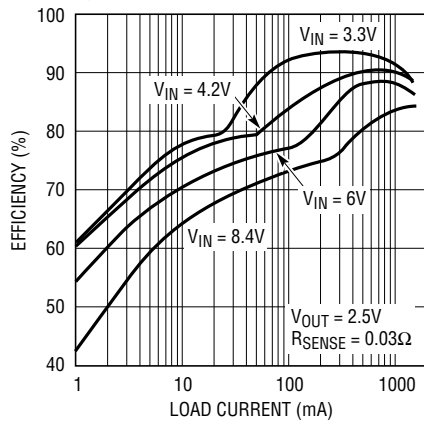

1622 G07

Load Step Transient Response Burst Enabled

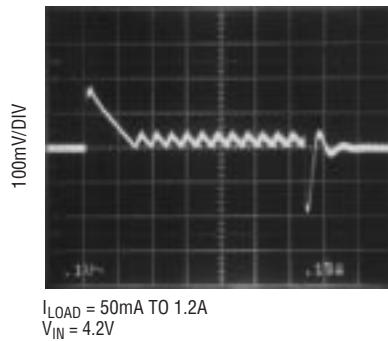

1622 G08

Load Step Transient Response Burst Inhibited

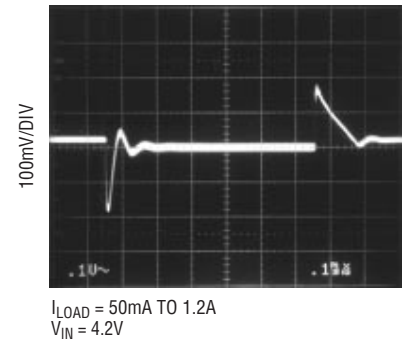

1622 G09

PIN FUNCTIONS

SENSE⁻ (Pin 1): The Negative Input to the Current Comparator.

I_{TH} (Pin 2): Error Amplifier Compensation Point. The current comparator threshold increases with this control voltage. Nominal voltage range for this pin is 0V to 1.2V.

V_{FB} (Pin 3): Receives the feedback voltage from an external resistive divider across the output capacitor.

RUN/SS (Pin 4): Combination of Soft-Start and Run Control Inputs. A capacitor to ground at this pin sets the ramp time to full output current. The time is approximately 0.45s/μF. Forcing this pin below 0.4V causes all circuitry to be shut down.

SYNC/MODE (Pin 5): This pin performs three functions. Greater than 2V on this pin allows Burst Mode operation at low load currents, while grounding or applying a clock signal on this pin defeats Burst Mode operation. An external clock between 625kHz and 750kHz applied to this pin forces the LTC1622 to operate at the external clock frequency. *Do not attempt to synchronize below 625kHz.* Pin 5 has an internal 1μA pull-up current source.

GND (Pin 6): Ground Pin.

PDRV (PIN 7): Gate Drive for the External P-Channel MOSFET. This pin swings from 0V to V_{IN}.

V_{IN} (Pin 8): Main Supply Pin. Must be closely decoupled to ground Pin 6.

OPERATION (Refer to Functional Diagram)

the I_{TH} pin will drop. When the I_{TH} voltage goes below 0.12V, the sleep signal goes high, turning off the external MOSFET. The sleep signal goes low when the I_{TH} voltage rises above 0.22V and the LTC1622 resumes normal operation. The next oscillator cycle will turn the external MOSFET on and the switching cycle repeats.

Frequency Synchronization

The LTC1622 can be externally driven by a TTL/CMOS compatible clock signal up to 750kHz. *Do not* synchronize the LTC1622 below its maximum default operating frequency of 625kHz as this may cause abnormal operation and an undesired frequency spectrum. The LTC1622 is synchronized to the rising edge of the clock. The external clock pulse width must be at least 100ns and not more than the period minus 200ns.

Synchronization is inhibited when the feedback voltage is below 0.3V. This is to prevent inductor current buildup under short-circuit conditions. Burst Mode operation is deactivated when the LTC1622 is externally driven by a clock.

Dropout Operation

When the input supply voltage decreases towards the output voltage, the rate of change of inductor current during the ON cycle decreases. This reduction means that the P-channel MOSFET will remain on for more than one oscillator cycle since the inductor current has not ramped up to the threshold set by EA. Further reduction in input supply voltage will eventually cause the P-channel MOSFET to be turned on 100%, i.e., DC. The output voltage will then be determined by the input voltage minus the voltage drop across the MOSFET, the sense resistor and the inductor.

Undervoltage Lockout

To prevent operation of the P-channel MOSFET below safe input voltage levels, an undervoltage lockout is incorporated into the LTC1622. When the input supply voltage drops below 2V, the P-channel MOSFET and all circuitry is turned off except the undervoltage block, which draws only several microamperes.

Short-Circuit Protection

When the output is shorted to ground, the frequency of the oscillator will be reduced to about 110kHz. This lower frequency allows the inductor current to safely discharge, thereby preventing current runaway. The oscillator's frequency will gradually increase to its nominal value when the feedback voltage increases above 0.65V. Note that synchronization is inhibited until the feedback voltage goes above 0.3V.

Overvoltage Protection

As a further protection, the overvoltage comparator in the LTC1622 will turn the external MOSFET off when the feedback voltage has risen 16% above the reference voltage of 0.8V. This comparator has a typical hysteresis of 35mV.

Slope Compensation and Peak Inductor Current

The inductor's peak current is determined by:

$$I_{PK} = \frac{V_{ITH}}{10(R_{SENSE})}$$

when the LTC1622 is operating below 40% duty cycle. However, once the duty cycle exceeds 40%, slope compensation begins and effectively reduces the peak inductor current. The amount of reduction is given by the curves in Figure 2.

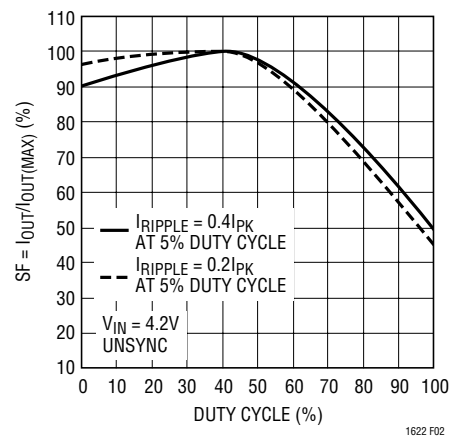

Figure 2. Maximum Output Current vs Duty Cycle

APPLICATIONS INFORMATION

The basic LTC1622 application circuit is shown in Figure 1. External component selection is driven by the load requirement and begins with the selection of L and R_{SENSE} . Next, the Power MOSFET and the output diode D1 are selected followed by C_{IN} and C_{OUT} .

R_{SENSE} Selection for Output Current

R_{SENSE} is chosen based on the required output current. With the current comparator monitoring the voltage developed across R_{SENSE} , the threshold of the comparator determines the inductor's peak current. The output current the LTC1622 can provide is given by:

$$I_{OUT} = \frac{0.08}{R_{SENSE}} - \frac{I_{RIPPLE}}{2}$$

where I_{RIPPLE} is the inductor peak-to-peak ripple current (see Inductor Value Calculation section).

A reasonable starting point for setting ripple current is $I_{RIPPLE} = (0.4)(I_{OUT})$. Rearranging the above equation, it becomes:

$$R_{SENSE} = \frac{1}{(15)(I_{OUT})} \text{ for Duty Cycle} < 40\%$$

However, for operation that is above 40% duty cycle, slope compensation has to be taken into consideration to select the appropriate value to provide the required amount of current. Using Figure 2, the value of R_{SENSE} is:

$$R_{SENSE} = \frac{SF}{(15)(I_{OUT})(100)}$$

Inductor Value Calculation

The operating frequency and inductor selection are inter-related in that higher operating frequencies permit the use of a smaller inductor for the same amount of inductor ripple current. However, this is at the expense of efficiency due to an increase in MOSFET gate charge losses.

The inductance value also has a direct effect on ripple current. The ripple current, I_{RIPPLE} , decreases with higher inductance or frequency and increases with higher V_{IN} or

V_{OUT} . The inductor's peak-to-peak ripple current is given by:

$$I_{RIPPLE} = \frac{V_{IN} - V_{OUT}}{f(L)} \left(\frac{V_{OUT} + V_D}{V_{IN} + V_D} \right)$$

where f is the operating frequency. Accepting larger values of I_{RIPPLE} allows the use of low inductances, but results in higher output voltage ripple and greater core losses. A reasonable starting point for setting ripple current is $I_{RIPPLE} = 0.4(I_{OUT(MAX)})$. Remember, the maximum I_{RIPPLE} occurs at the maximum input voltage.

With Burst Mode operation selected on the LTC1622, the ripple current is normally set such that the inductor current is continuous during the burst periods. Therefore, the peak-to-peak ripple current should not exceed:

$$I_{RIPPLE} \leq \frac{0.036}{R_{SENSE}}$$

This implies a minimum inductance of:

$$L_{MIN} = \frac{V_{IN} - V_{OUT}}{f \left(\frac{0.036}{R_{SENSE}} \right)} \left(\frac{V_{OUT} + V_D}{V_{IN} + V_D} \right)$$

(Use $V_{IN(MAX)} = V_{IN}$)

A smaller value than L_{MIN} could be used in the circuit; however, the inductor current will not be continuous during burst periods.

Inductor Core Selection

Once the value for L is known, the type of inductor must be selected. High efficiency converters generally cannot afford the core loss found in low cost powdered iron cores, forcing the use of more expensive ferrite, molypermalloy or Kool Mu® cores. Actual core loss is independent of core size for a fixed inductor value, but it is very dependent on inductance selected. As inductance increases, core losses go down. Unfortunately, increased inductance requires more turns of wire and therefore copper losses will increase. Ferrite designs have very low core losses and are

Kool Mu is a registered trademark of Magnetics, Inc.

APPLICATIONS INFORMATION

preferred at high switching frequencies, so design goals can concentrate on copper loss and preventing saturation. Ferrite core materials saturate “hard,” which means that the inductance collapses abruptly when the peak design current is exceeded. This results in an abrupt increase in inductor ripple current and consequently, output voltage ripple. Do not allow the core to saturate!

Molypermalloy (from Magnetics, Inc.) is a very good, low loss core material for toroids, but it is more expensive than ferrite. A reasonable compromise from the same manufacturer is Kool Mu. Toroids are very space efficient, especially when you can use several layers of wire. Because they generally lack a bobbin, mounting is more difficult. However, new surface mountable designs that do not increase the height significantly are available.

Power MOSFET Selection

An external P-channel power MOSFET must be selected for use with the LTC1622. The main selection criteria for the power MOSFET are the threshold voltage $V_{GS(TH)}$ and the “on” resistance $R_{DS(ON)}$, reverse transfer capacitance C_{RSS} and total gate charge.

Since the LTC1622 is designed for operation down to low input voltages, a sublogic level threshold MOSFET ($R_{DS(ON)}$ guaranteed at $V_{GS} = 2.5V$) is required for applications that work close to this voltage. When these MOSFETs are used, make sure that the input supply to the LTC1622 is less than the absolute maximum MOSFET V_{GS} rating, typically 8V. The gate drive voltage levels are from ground to V_{IN} .

The required minimum $R_{DS(ON)}$ of the MOSFET is governed by its allowable power dissipation. For applications that may operate the LTC1622 in dropout, i.e., 100% duty cycle, at its worst case the required $R_{DS(ON)}$ is given by:

$$R_{DS(ON)DC=100\%} = \frac{P_P}{(I_{OUT(MAX)})^2(1 + \delta p)}$$

where P_P is the allowable power dissipation and δp is the temperature dependency of $R_{DS(ON)}$. $(1 + \delta p)$ is generally given for a MOSFET in the form of a normalized $R_{DS(ON)}$ vs temperature curve, but $\delta p = 0.005/^\circ C$ can be used as an approximation for low voltage MOSFETs.

In applications where the maximum duty cycle is less than 100% and the LTC1622 is in continuous mode, the $R_{DS(ON)}$ is governed by:

$$R_{DS(ON)} \cong \frac{P_P}{(DC)I_{OUT}^2(1 + \delta p)}$$

where DC is the maximum operating duty cycle of the LTC1622.

When the LTC1622 is operating in continuous mode, the MOSFET power dissipation is:

$$P_{MOSFET} = \frac{V_{OUT} + V_D}{V_{IN} + V_D} (I_{OUT})^2 (1 + \delta p) R_{DS(ON)} + K (V_{IN})^2 (I_{OUT}) (C_{RSS}) (f)$$

where K is a constant inversely related to gate drive current. Because of the high switching frequency, the second term relating to switching loss is important not to overlook. The constant $K = 3$ can be used to estimate the contributions of the two terms in the MOSFET dissipation equation.

Output Diode Selection

The catch diode carries load current during the off-time. The average diode current is therefore dependent on the P-channel switch duty cycle. At high input voltages the diode conducts most of the time. As V_{IN} approaches V_{OUT} the diode conducts only a small fraction of the time. The most stressful condition for the diode is when the output is short circuited. Under this condition the diode must safely handle I_{PEAK} at close to 100% duty cycle. Therefore, it is important to adequately specify the diode peak current and average power dissipation so as not to exceed the diode ratings.

Under normal load conditions, the average current conducted by the diode is:

$$I_D = \left(\frac{V_{IN} - V_{OUT}}{V_{IN} + V_D} \right) I_{OUT}$$

APPLICATIONS INFORMATION

The allowable forward voltage drop in the diode is calculated from the maximum short-circuit current as:

$$V_F \approx \frac{P_D}{I_{SC(MAX)}}$$

where P_D is the allowable power dissipation and will be determined by efficiency and/or thermal requirements.

A fast switching diode must also be used to optimize efficiency. Schottky diodes are a good choice for low forward drop and fast switching times. Remember to keep lead length short and observe proper grounding (see Board Layout Checklist) to avoid ringing and increased dissipation.

C_{IN} and C_{OUT} Selection

In continuous mode, the source current of the P-channel MOSFET is a square wave of duty cycle $(V_{OUT} + V_D)/(V_{IN} + V_D)$. To prevent large voltage transients, a low ESR input capacitor sized for the maximum RMS current must be used. The maximum RMS capacitor current is given by:

$$C_{IN} \text{ Required } I_{RMS} \approx I_{MAX} \frac{[V_{OUT}(V_{IN} - V_{OUT})]^{1/2}}{V_{IN}}$$

This formula has a maximum at $V_{IN} = 2V_{OUT}$, where $I_{RMS} = I_{OUT}/2$. This simple worst-case condition is commonly used for design because even significant deviations do not offer much relief. Note that capacitor manufacturer's ripple current ratings are often based on 2000 hours of life. This makes it advisable to further derate the capacitor, or to choose a capacitor rated at a higher temperature than required. Several capacitors may be paralleled to meet the size or height requirements in the design. Due to the high operating frequency of the LTC1622, ceramic capacitors can also be used for C_{IN} . Always consult the manufacturer if there is any question.

The selection of C_{OUT} is driven by the required effective series resistance (ESR). Typically, once the ESR requirement is satisfied, the capacitance is adequate for filtering. The output ripple (ΔV_{OUT}) is approximated by:

$$\Delta V_{OUT} \approx I_{RIPPLE} \left(ESR + \frac{1}{8fC_{OUT}} \right)$$

where f is the operating frequency, C_{OUT} is the output capacitance and I_{RIPPLE} is the ripple current in the inductor. The output ripple is highest at maximum input voltage since ΔI_L increases with input voltage.

The choice of using a smaller output capacitance increases the output ripple voltage due to the frequency dependent term, but can be compensated for by using capacitors of very low ESR to maintain low ripple voltage. The I_{TH} pin OPTI-LOOP compensation components can be optimized to provide stable, high performance transient response regardless of the output capacitors selected.

Manufacturers such as Nichicon, United Chemicon and Sanyo should be considered for high performance through-hole capacitors. The OS-CON semiconductor dielectric capacitor available from Sanyo has the lowest ESR (size) product of any aluminum electrolytic at a somewhat higher price. Once the ESR requirement for C_{OUT} has been met, the RMS current rating generally far exceeds the $I_{RIPPLE(P-P)}$ requirement.

In surface mount applications, multiple capacitors may have to be paralleled to meet the ESR or RMS current handling requirements of the application. Aluminum electrolytic and dry tantalum capacitors are both available in surface mount configurations. In the case of tantalum, it is critical that the capacitors are surge tested for use in switching power supplies. An excellent choice is the AVX TPS, AVX TPSV and KEMET T510 series of surface mount tantalum, available in case heights ranging from 2mm to 4mm. Other capacitor types include Sanyo OS-CON, Sanyo POSCAP, Nichicon PL series and the Panasonic SP series.

Low Supply Operation

Although the LTC1622 can function down to 2V, the maximum allowable output current is reduced when V_{IN} decreases below 3V. Figure 3 shows the amount of change as the supply is reduced down to 2V. Also shown in Figure 3 is the effect of V_{IN} on V_{REF} as V_{IN} goes below 2.3V. Remember the maximum voltage on the I_{TH} pin defines

APPLICATIONS INFORMATION

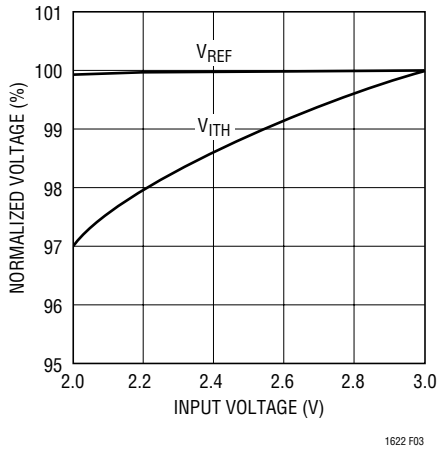

Figure 3. Line Regulation of V_{REF} and V_{ITH}

the maximum current sense voltage that sets the maximum output current.

Setting Output Voltage

The LTC1622 develops a 0.8V reference voltage between the feedback (Pin 3) terminal and ground (see Figure 4). By selecting resistor R1, a constant current is caused to flow through R1 and R2 to set the output voltage. The regulated output voltage is determined by:

$$V_{OUT} = 0.8 \left(1 + \frac{R2}{R1} \right)$$

For most applications, a 30k resistor is suggested for R1. To prevent stray pickup, an optional 100pF capacitor is suggested across R1 located close to LTC1622.

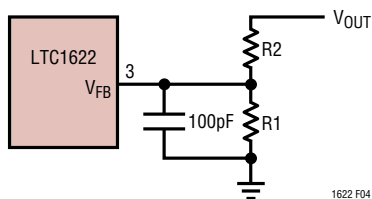

Figure 4. Setting Output Voltage

Efficiency Considerations

The efficiency of a switching regulator is equal to the output power divided by the input power times 100%. It is often useful to analyze individual losses to determine what

is limiting the efficiency and which change would produce the most improvement. Efficiency can be expressed as:

$$\text{Efficiency} = 100\% - (\eta1 + \eta2 + \eta3 + \dots)$$

where $\eta1$, $\eta2$, etc. are the individual losses as a percentage of input power.

Although all dissipative elements in the circuit produce losses, four main sources usually account for most of the losses in LTC1622 circuits: 1) LTC1622 DC bias current, 2) MOSFET gate charge current, 3) I^2R losses, 4) voltage drop of the output diode and 5) transition losses.

1. The V_{IN} current is the DC supply current, given in the electrical characteristics, that excludes MOSFET driver and control currents. V_{IN} current results in a small loss which increases with V_{IN} .
2. MOSFET gate charge current results from switching the gate capacitance of the power MOSFET. Each time a MOSFET gate is switched from low to high to low again, a packet of charge dQ moves from V_{IN} to ground. The resulting dQ/dt is a current out of V_{IN} which is typically much larger than the DC supply current. In continuous mode, $I_{GATECHG} = f(Qp)$.
3. I^2R losses are predicted from the DC resistances of the MOSFET, inductor and current shunt. In continuous mode the average output current flows through L but is "chopped" between the P-channel MOSFET in series with R_{SENSE} and the output diode. The MOSFET $R_{DS(ON)}$ plus R_{SENSE} multiplied by duty cycle can be summed with the resistance of the inductor to obtain I^2R losses.
4. The output diode is a major source of power loss at high currents and gets worse at high input voltages. The diode loss is calculated by multiplying the forward voltage drop times the diode duty cycle multiplied by the load current. For example, assuming a duty cycle of 50% with a Schottky diode forward voltage drop of 0.4V, the loss increases from 0.5% to 8% as the load current increases from 0.5A to 2A.
5. Transition losses apply to the external MOSFET and increase with higher operating frequencies and input voltages. Transition losses can be estimated from:

APPLICATIONS INFORMATION

$$\text{Transition Loss} = 3(V_{IN})^2 I_{O(MAX)} C_{RSS}(f)$$

Other losses including C_{IN} and C_{OUT} ESR dissipative losses, and inductor core losses, generally account for less than 2% total additional loss.

Run/Soft-Start Function

The RUN/SS pin is a dual purpose pin that provides the soft-start function and a means to shut down the LTC1622. Soft-start reduces input surge current from V_{IN} by gradually increasing the internal current limit. Power supply sequencing can also be accomplished using this pin.

An internal $2.5\mu\text{A}$ current source charges up an external capacitor C_{SS} . When the voltage on the RUN/SS reaches 0.7V the LTC1622 begins operating. As the voltage on RUN/SS continues to ramp from 0.7V to 1.8V, the internal current limit is also ramped at a proportional linear rate. The current limit begins near 0A (at $V_{RUN/SS} = 0.7\text{V}$) and ends at $0.1/R_{SENSE}$ ($V_{RUN/SS} \geq 1.8\text{V}$). The output current thus ramps up slowly, reducing the starting surge current required from the input power supply. If the RUN/SS has been pulled all the way to ground, there will be a delay before the current limit starts increasing and is given by:

$$t_{DELAY} = 2.8 \cdot 10^5 \cdot C_{SS} \text{ in seconds}$$

Pulling the RUN/SS pin below 0.4V puts the LTC1622 into a low quiescent current shutdown ($I_Q < 15\mu\text{A}$).

Foldback Current Limiting

As described in the Output Diode Selection, the worst-case dissipation occurs with a short-circuited output when the diode conducts the current limit value almost continuously. To prevent excessive heating in the diode, foldback current limiting can be added to reduce the current in proportion to the severity of the fault.

Foldback current limiting is implemented by adding diode D_{FB} (1N4148 or equivalent) between the output and the I_{TH} pin as shown in Figure 5. In a hard short ($V_{OUT} = 0\text{V}$), the current will be reduced to approximately 50% of the maximum output current.

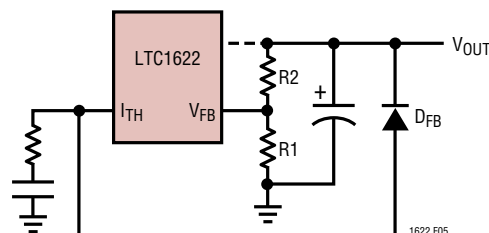

Figure 5. Foldback Current Limiting

Design Example

Assume the LTC1622 is used in a single lithium-ion battery-powered cellular phone application. The V_{IN} will be operating from a maximum of 4.2V down to a minimum of 2.7V. Load current requirement is a maximum of 1.5A but most of the time it will be on standby mode, requiring only 2mA. Efficiency at both low and high load current is important. Output voltage is 2.5V.

In the above application, Burst Mode operation is enabled by connecting Pin 5 to V_{IN} .

$$\text{Maximum Duty Cycle} = \frac{V_{OUT} + V_D}{V_{IN(MIN)} + V_D} = 93\%$$

From Figure 2, SF = 57%.

Use the curve of Figure 2 since the operating frequency is the free running frequency of the LTC1622.

$$R_{SENSE} = \frac{SF}{(15)(I_{OUT})(100)} = \frac{0.57}{(15)(1.5A)} = 0.0253\Omega$$

In the application, a 0.025Ω resistor is used. For the inductor, the required value is:

$$L_{MIN} = \frac{4.2 - 2.5}{550\text{kHz}} \left(\frac{2.5 + 0.3}{4.2 + 0.3} \right) = 1.33\mu\text{H}$$

In the application, a $3.9\mu\text{H}$ inductor is used to reduce inductor ripple current and thus, output voltage ripple.

For the selection of the external MOSFET, the $R_{DS(ON)}$ must be guaranteed at 2.5V since the LTC1622 has to work

APPLICATIONS INFORMATION

down to 2.7V. Let's assume that the MOSFET dissipation is to be limited to $P_P = 250\text{mW}$ and its thermal resistance is 50°C/W . Hence the junction temperature at $T_A = 25^\circ\text{C}$ will be 37.5°C and $\delta p = 0.005 (37.5 - 25) = 0.0625$. The required $R_{DS(ON)}$ is then given by:

$$R_{DS(ON)} \cong \frac{P_P}{DC(I_{OUT})^2 (1 + \delta p)} = 0.11\Omega$$

The P-channel MOSFET requirement can be met by an Si6433DQ.

The requirement for the Schottky diode is the most stringent when $V_{OUT} = 0\text{V}$, i.e., short circuit. With a 0.025Ω R_{SENSE} resistor, the short-circuit current through the Schottky is $0.1/0.025 = 4\text{A}$. An MBR340T3 Schottky diode is chosen. With 4A flowing through, the diode is rated with a forward voltage of 0.4V. Therefore, the worst-case power dissipated by the diode is 1.6W. The addition of D_{FB} (Figure 5) will reduce the diode dissipation to approximately 0.8W.

The input capacitor requires an RMS current rating of at least 0.75A at temperature, and C_{OUT} will require an ESR of 0.1Ω for optimum efficiency.

PC Board Layout Checklist

When laying out the printed circuit board, the following checklist should be used to ensure proper operation of the LTC1622. These items are illustrated graphically in the

layout diagram in Figure 6. Check the following in your layout:

1. Is the Schottky diode closely connected between ground at (–) lead of C_{IN} and drain of the external MOSFET?
2. Does the (+) plate of C_{IN} connect to the sense resistor as closely as possible? This capacitor provides AC current to the MOSFET.
3. Is the input decoupling capacitor ($0.1\mu\text{F}$) connected closely between V_{IN} (Pin 8) and ground (Pin 6)?
4. Connect the end of R_{SENSE} as close to V_{IN} (Pin 8) as possible. The V_{IN} pin is the $SENSE^+$ of the current comparator.
5. Is the trace from the $SENSE^-$ (Pin 1) to the Sense resistor kept short? Does the trace connect close to R_{SENSE} ?
6. Keep the switching node, SW, away from sensitive small signal nodes.
7. Does the V_{FB} pin connect directly to the feedback resistors? The resistive divider R1 and R2 must be connected between the (+) plate of C_{OUT} and signal ground. Optional capacitor C1 should be located as close as possible to the LTC1622.

R1 and R2 should be located as close as possible to the LTC1622. R2 should connect to the output as close to the load as practicable.

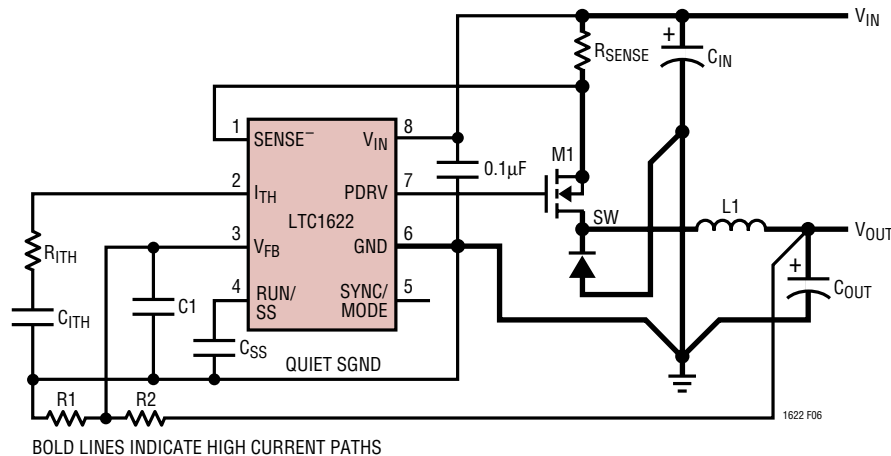
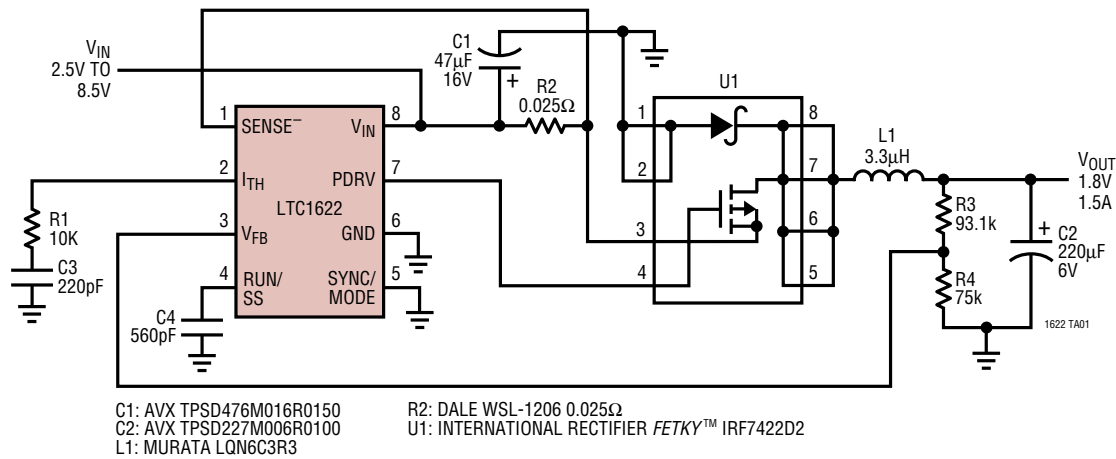

Figure 6. LTC1622 Layout Diagram (See PC Board Layout Checklist)

TYPICAL APPLICATIONS

LTC1622 1.8V/1.5A Regulator with Burst Mode Operation Disabled



LTC1622 2.5V/2A Regulator with Burst Mode Operation Enabled

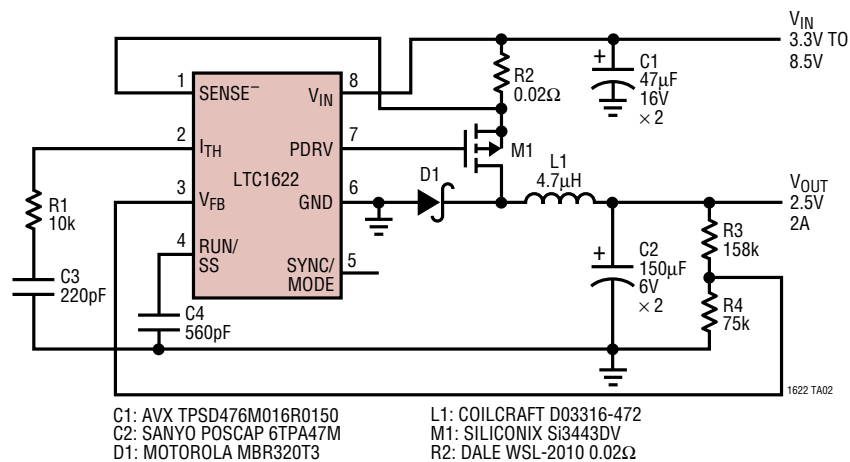

FETKY is a trademark of International Rectifier Corporation.

TYPICAL APPLICATIONS

LTC1622 2.5V/3A Regulator with External Frequency Synchronization

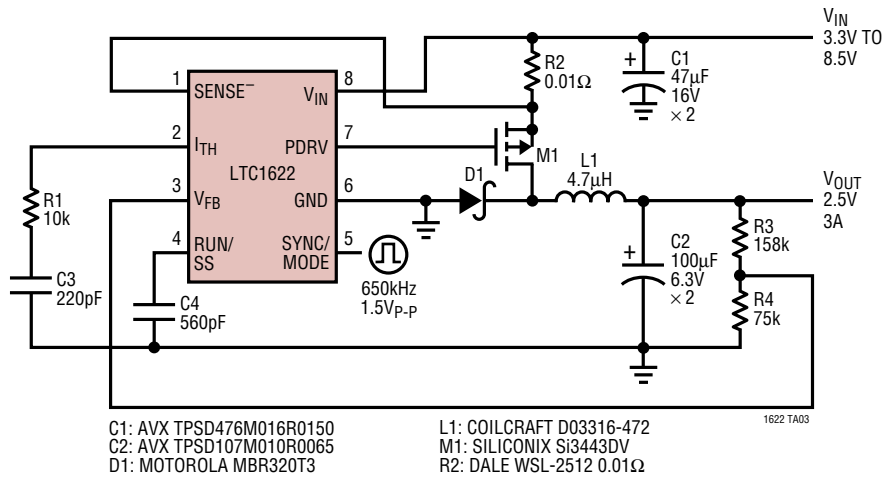

Zeta Converter with Foldback Current Limit

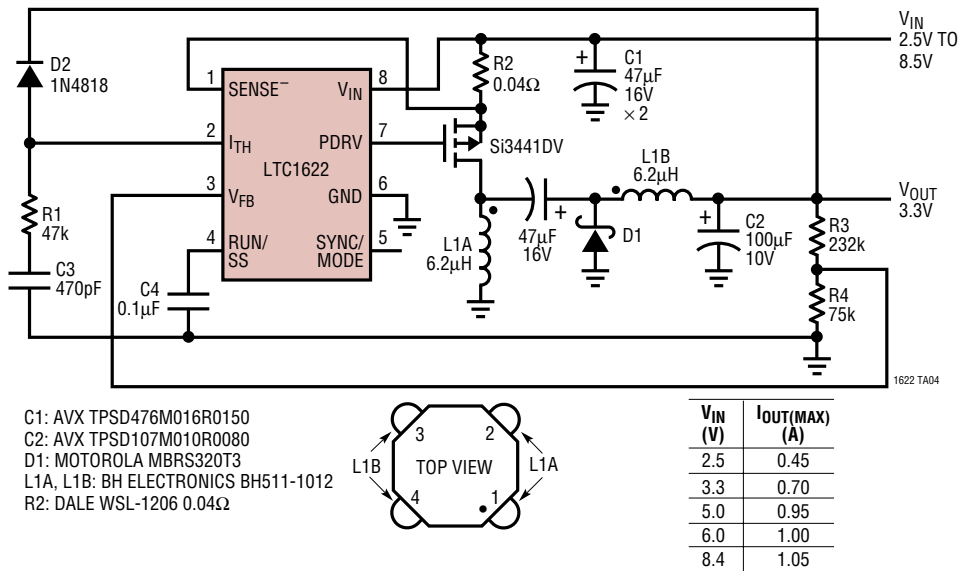

PACKAGE DESCRIPTION Dimensions in inches (millimeters) unless otherwise noted.

MS8 Package
8-Lead Plastic MSOP
 (LTC DWG # 05-08-1660)

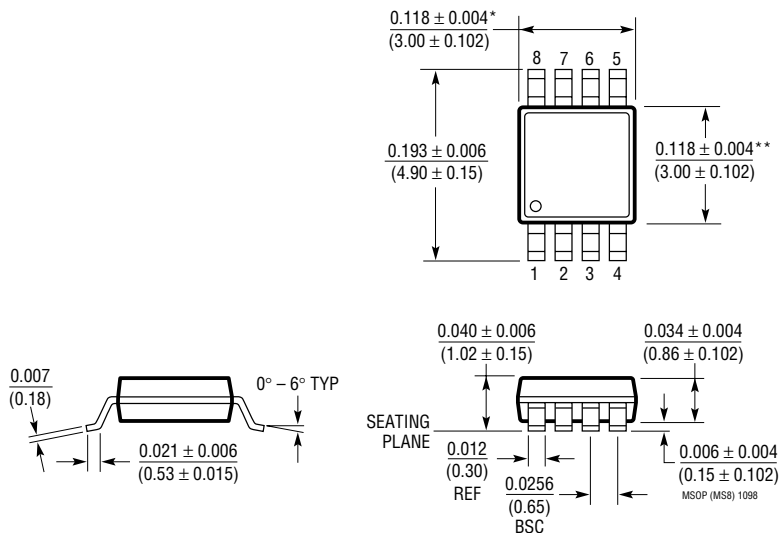

- * DIMENSION DOES NOT INCLUDE MOLD FLASH, PROTRUSIONS OR GATE BURRS. MOLD FLASH, PROTRUSIONS OR GATE BURRS SHALL NOT EXCEED 0.006" (0.152mm) PER SIDE
- ** DIMENSION DOES NOT INCLUDE INTERLEAD FLASH OR PROTRUSIONS. INTERLEAD FLASH OR PROTRUSIONS SHALL NOT EXCEED 0.006" (0.152mm) PER SIDE

S8 Package
8-Lead Plastic Small Outline (Narrow 0.150)
 (LTC DWG # 05-08-1610)

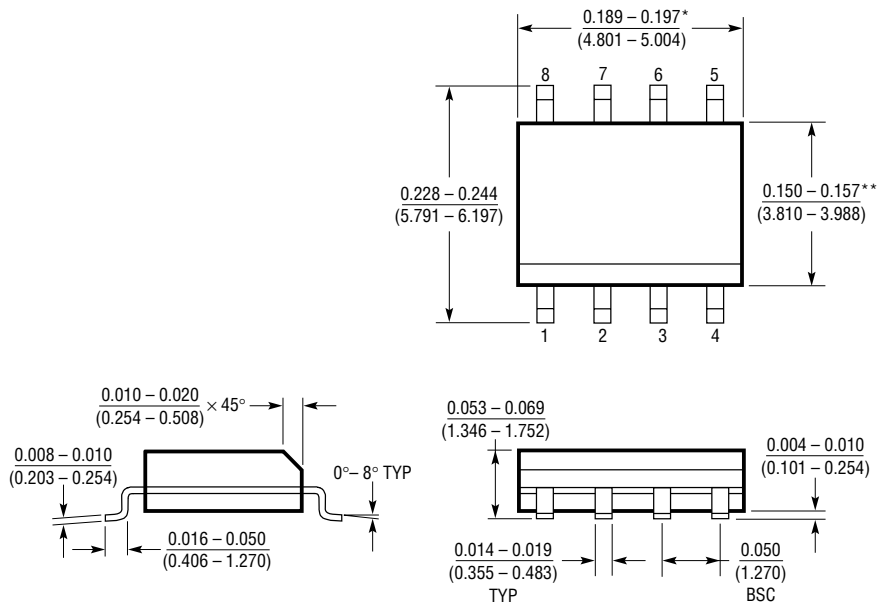

- * DIMENSION DOES NOT INCLUDE MOLD FLASH. MOLD FLASH SHALL NOT EXCEED 0.006" (0.152mm) PER SIDE
- ** DIMENSION DOES NOT INCLUDE INTERLEAD FLASH. INTERLEAD FLASH SHALL NOT EXCEED 0.010" (0.254mm) PER SIDE

S08 1298

TYPICAL APPLICATION

Small Footprint 3.3V/1A Regulator

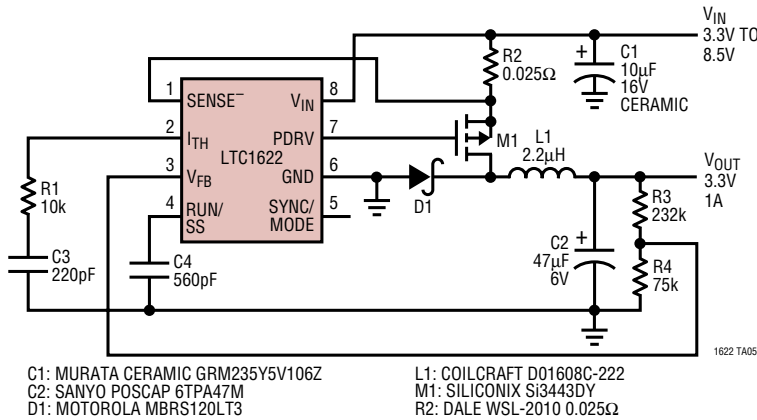

Efficiency vs Load Current

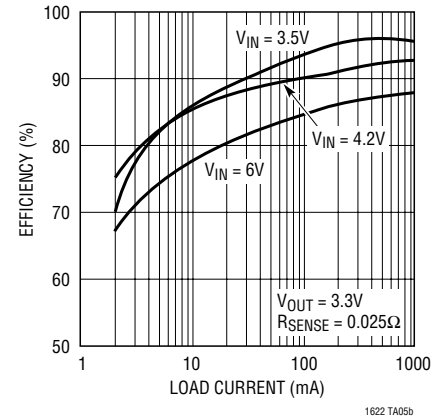

Boost Converter 3.3V/2.5A

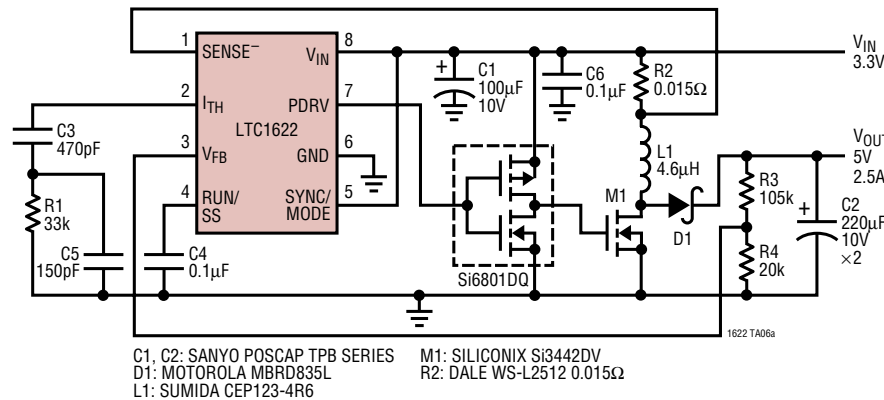

Efficiency vs Load Current With LTC1622 Configured as Boost Converter

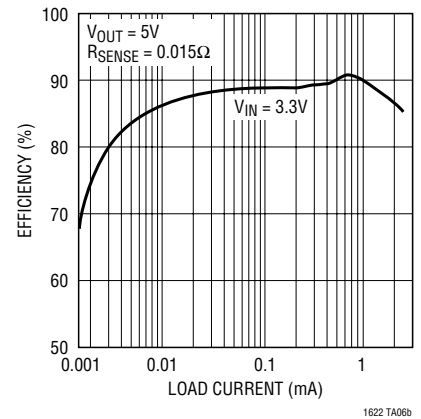

RELATED PARTS

PART NUMBER	DESCRIPTION	COMMENTS
LTC1147 Series	High Efficiency Step-Down Switching Regulator Controllers	100% DC, $3.5V \leq V_{IN} \leq 16V$, HV Version Has $20V_{IN}$
LT1375/LT1376	1.5A, 500kHz Step-Down Switching Regulators	High Frequency, Small Inductor, High Efficiency
LTC1436/LTC1436-PLL	High Efficiency, Low Noise, Synchronous Step-Down Converters	24-Pin Narrow SSOP, $3.5V \leq V_{IN} \leq 36V$
LTC1438/LTC1439	Dual, Low Noise, Synchronous Step-Down Converters	Multiple Output Capability, $3.5V \leq V_{IN} \leq 36V$
LTC1474/LTC1475	Low Quiescent Current Step-Down DC/DC Converters	Monolithic, MSOP, $I_{OUT} = 10\mu A$
LTC1624	High Efficiency SO-8 N-Channel Switching Regulator Controller	8-Pin N-Channel Drive, $3.5V \leq V_{IN} \leq 36V$
LTC1626	Low Voltage, High Efficiency Step-Down DC/DC Converter	Monolithic, Constant Off-Time, $2.5V \leq V_{IN} \leq 6V$
LTC1627/LTC1707	Low Voltage, Monolithic Synchronous Step-Down Regulator	Low Supply Voltage Range: 2.65V to 8V, 0.5A
LTC1628	Dual High Efficiency 2-Phase Step-Down Controller	Antiphase Drive, $3.5V \leq V_{IN} \leq 36V$, Protection
LTC1772	SOT-23 Current Mode Step-Down Controller	6-Lead SOT-23, $2.5V \leq V_{IN} \leq 9.8V$, 550kHz
LTC1735	High Efficiency, Low Noise Synchronous Switching Controller	Burst Mode Operation, Protection, $3.5V \leq V_{IN} \leq 36V$

Looking for pricing, stock, or lifecycle information?

Click below to explore more details on WIN SOURCE:

 [View LTC1622CMS8#PBF on WIN SOURCE](#)

 [Linear Technology](#) Information

Optimize Your Supply Chain with WIN SOURCE Solutions

-  Global Sourcing Solution
-  Obsolete Management
-  Cost Control Management
-  Shortage Management
-  Alternative Solution
-  Excess Inventory Management