



**THE DATASHEET OF
LTC1685CS8#PBF**



52Mbps, Precision Delay, RS485 Fail-Safe Transceiver

FEATURES

- **Precision Propagation Delay Over Temperature:**
Receiver/Driver: 18.5ns \pm 3.5ns
- **High Data Rate: 52Mbps**
- Low t_{PLH}/t_{PHL} Skew:
Receiver/Driver: 500ps Typ
- -7V to 12V RS485 Input Common Mode Range
- **Guaranteed Fail-Safe Receiver Operation Over the Entire Common Mode Range**
- High Receiver Input Resistance: \geq 22k, Even When Unpowered
- Short-Circuit Protected
- Thermal Shutdown Protected
- Driver Maintains High Impedance in Three-State or with Power Off
- Single 5V Supply
- Pin Compatible with LTC485
- 45dB CMRR at 26MHz

APPLICATIONS

- High Speed RS485/RS422 Transceivers
- Level Translator
- Backplane Transceiver
- STS-1/OC-1 Data Transceiver
- Fast-20, Fast-40 SCSI Transceivers

DESCRIPTION

The LTC[®]1685 is a high speed, precision delay RS485 transceiver that can operate at data rates as high as 52Mbps. The device also meets the requirements of RS422.

A unique architecture provides very stable propagation delays and low skew over a wide common mode and ambient temperature range.

The driver and receiver feature three-state outputs, with disabled driver outputs maintaining high impedance over the entire common mode range. A short circuit feature detects shorted outputs and substantially reduces driver output current. A similar feature also protects the receiver output from short circuits. Thermal shutdown circuitry protects from excessive power dissipation.

The receiver has a fail-safe feature that guarantees a high output state when the inputs are shorted or are left floating. The LTC1685 RS485 transceiver guarantees receiver fail-safe operation over the *entire* common mode range (-7V to 12V). Input resistance will remain \geq 22k when the device is unpowered or disabled.

The LTC1685 operates from a single 5V supply and draws only 7mA of supply current.

 LTC and LT are registered trademarks of Linear Technology Corporation.

TYPICAL APPLICATION

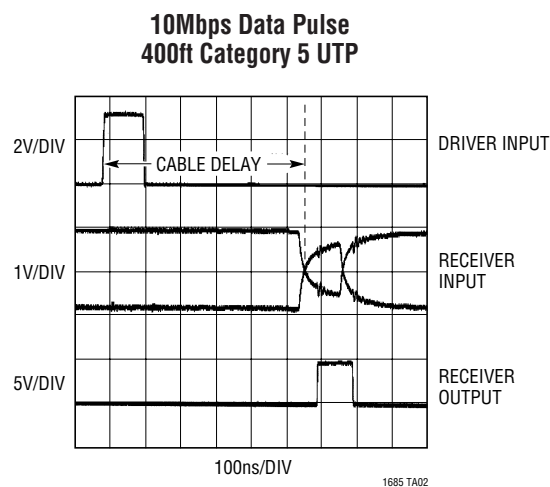
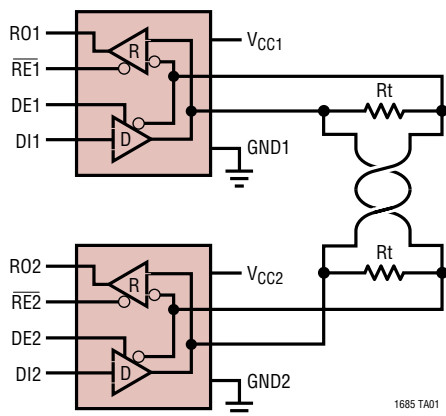

ABSOLUTE MAXIMUM RATINGS

(Note 1)

Supply Voltage (V_{DD})	10V
Control Input Currents	-100mA to 100mA
Control Input Voltages	-0.5V to $V_{DD} + 0.5V$
Driver Input Voltages	-0.5V to $V_{DD} + 0.5V$
Driver Output Voltages	+12V/-7V
Receiver Input Voltages	+12V/-7V
Receiver Output Voltages	-0.5V to $V_{DD} + 0.5V$
Receiver Input Differential	10V
Short-Circuit Duration (Driver V_{OUT} : -7V to 10V, Receiver V_{OUT} : 0V to V_{DD})	Indefinite
Operating Temperature Range	
LTC1685C	0°C to 70°C
LTC1685I	-40°C to 85°C
Storage Temperature Range	-65°C to 150°C
Lead Temperature (Soldering, 10 sec)	300°C

PACKAGE/ORDER INFORMATION

<p>S8 PACKAGE 8-LEAD PLASTIC SO $T_{JMAX} = 125^{\circ}C$, $\theta_{JA} = 150^{\circ}C/W$</p>	ORDER PART NUMBER
	LTC1685CS8 LTC1685IS8
	S8 PART MARKING
	1685 1685I

Consult factory for Military grade parts.

DC ELECTRICAL CHARACTERISTICS

The ● denotes the specifications which apply over the full operating temperature range, otherwise specifications are at $T_A = 25^{\circ}C$. $V_{DD} = 5V \pm 5\%$, unless otherwise noted. (Notes 2, 3)

SYMBOL	PARAMETER	CONDITIONS	MIN	TYP	MAX	UNITS
V_{OD1}	Differential Driver Output (Unloaded)	$I_{OUT} = 0$			V_{DD}	V
V_{OD2}	Differential Driver Output (With Load)	$R = 50\Omega$ (RS422) $R = 27\Omega$ (RS485), Figure 1	2 1.5		V_{DD}	V V
ΔV_{OD}	Change in Magnitude of Driver Differential Output Voltage for Complementary Output States	$R = 27\Omega$ or 50Ω , Figure 1			0.2	V
V_{OC}	Driver Common Mode Output Voltage	$R = 27\Omega$ or 50Ω , $V_{DD} = 5V$, Figure 1	2		3	V
$\Delta V_{OC} $	Change in Magnitude of Driver Common Mode Output Voltage for Complementary Output States	$R = 27\Omega$ or 50Ω , Figure 1			0.2	V
V_{IH}	Input High Voltage	DE, DI, \overline{RE}	2			V
V_{IL}	Input Low Voltage	DE, DI, \overline{RE}			0.8	V
I_{IN1}	Input Current	DE, DI, \overline{RE}	-1		1	μA
I_{IN2}	Input Current (A, B)	$V_A, V_B = 12V$, DE = 0, $V_{DD} = 0V$ or 5.25V $V_A, V_B = -7V$, DE = 0, $V_{DD} = 0V$ or 5.25V			500	μA μA
V_{TH}	Differential Input Threshold Voltage for Receiver	$-7V \leq V_{CM} \leq 12V$	-0.3		0.3	V
ΔV_{TH}	Receiver Input Hysteresis	$V_{CM} = 0V$		25		mV
V_{OH}	Receiver Output High Voltage	$I_{OUT} = -4mA$, $V_{ID} = 300mV$	3.5	4.8		V
V_{OL}	Receiver Output Low Voltage	$I_{OUT} = 4mA$, $V_{ID} = -300mV$			0.4	V
I_{OZR}	Three-State (High Impedance) Output Current at Receiver	$0.4V \leq V_{OUT} \leq 2.4V$	-1		1	μA
I_{DD}	Supply Current	No Load, Pins 2, 3, 4 = 0V or V_{DD}		7	12	mA
I_{OSD1}	Driver Short-Circuit Current, $V_{OUT} = HIGH$	$V_{OUT} = -7V$ or 10V (Note 5)			20	mA

DC ELECTRICAL CHARACTERISTICS

The ● denotes the specifications which apply over the full operating temperature range, otherwise specifications are at $T_A = 25^\circ\text{C}$. $V_{DD} = 5V \pm 5\%$, unless otherwise noted. (Notes 2, 3)

SYMBOL	PARAMETER	CONDITIONS	MIN	TYP	MAX	UNITS	
I_{OSD2}	Driver Short-Circuit Current, $V_{OUT} = \text{LOW}$	$V_{OUT} = -7V$ or $10V$ (Note 5)	●		20	mA	
I_{OSR}	Receiver Short-Circuit Current	$V_{OUT} = 0V$ or V_{DD} (Note 5)	●		20	mA	
R_{IN}	Input Resistance	$-7V \leq V_{CM} \leq 12V$	●	22		k Ω	
C_{IN}	Input Capacitance	A, B Inputs, D, DE, \overline{RE}		3		pF	
	Open-Circuit Input Voltage, Figure 5	$V_{DD} = 5V$ (Note 4)	●	3.2	3.3	3.4	V
Fail-Safe Time	Time to Detect Fail-Safe Condition			2		μs	
CMRR	Receiver Input Common Mode Rejection Ratio	$V_{CM} = 2.6V$, $f = 26\text{MHz}$		45		dB	
C_{LOAD}	Receiver and Driver Output Load Capacitance	(Note 4)	●		500	pF	

SWITCHING CHARACTERISTICS

The ● denotes the specifications which apply over the full operating temperature range, otherwise specifications are at $T_A = 25^\circ\text{C}$. $V_{DD} = 5V$, unless otherwise noted. (Notes 2, 3)

SYMBOL	PARAMETER	CONDITIONS	MIN	TYP	MAX	UNITS	
t_{PLH} , t_{PHL}	Driver Input-to-Output Propagation Delay	$R_{DIFF} = 54\Omega$, $C_{L1} = C_{L2} = 100\text{pF}$, Figures 3, 5, LTC1685C LTC1685I	● ●	15 13	18.5 18.5	22 25	ns ns
t_{SKEW}	Driver Output A-to-Output B Skew	$R_{DIFF} = 54\Omega$, $C_{L1} = C_{L2} = 100\text{pF}$, Figures 3, 5		500			ps
t_r , t_f	Driver Rise/Fall Time	$R_{DIFF} = 54\Omega$, $C_{L1} = C_{L2} = 100\text{pF}$, Figures 3, 5		3.5			ns
t_{ZH}	Driver Enable to Output High	$C_L = 100\text{pF}$, S2 Closed, Figures 4, 6	●		25	50	ns
t_{ZL}	Driver Enable to Output Low	$C_L = 100\text{pF}$, S1 Closed, Figures 4, 6	●		25	50	ns
t_{LZ}	Driver Disable from Low	$C_L = 15\text{pF}$, S1 Closed, Figures 4, 6	●		25	50	ns
t_{HZ}	Driver Disable from High	$C_L = 15\text{pF}$, S2 Closed, Figures 4, 6	●		25	50	ns
t_{PLH} , t_{PHL}	Receiver Input-to-Output Propagation Delay	$C_L = 15\text{pF}$, Figures 3, 7 LTC1685C LTC1685I	● ●	15 13	18.5 18.5	22 25	ns ns
t_{SQD}	Receiver Skew $ t_{PLH} - t_{PHL} $	$C_L = 15\text{pF}$, Figures 3, 7		500			ps
t_{ZL}	Receiver Enable to Output Low	$C_L = 15\text{pF}$, S1 Closed, Figures 2, 8	●		25	50	ns
t_{ZH}	Receiver Enable to Output High	$C_L = 15\text{pF}$, S2 Closed, Figures 2, 8	●		25	50	ns
t_{LZ}	Receiver Disable from Low	$C_L = 15\text{pF}$, S1 Closed, Figures 2, 8	●		25	50	ns
t_{HZ}	Receiver Disable from High	$C_L = 15\text{pF}$, S2 Closed, Figures 2, 8	●		25	50	ns
	Maximum Receiver Input Rise/Fall Times	(Note 4)	●			2000	ns
$t_{PKG-PKG}$	Package-to-Package Skew	Same Temperature (Note 4)		1.5			ns
	Minimum Input Pulse Width	$V_{DD} = 5V \pm 5\%$ (Note 4) LTC1685C LTC1685I	● ●		17 20	19.2 25	ns ns
	Maximum Data Rate	$V_{DD} = 5V \pm 5\%$ (Note 4) LTC1685C LTC1685I	● ●	52 40	60 50		Mbps Mbps
	Maximum Input Frequency	$V_{DD} = 5V \pm 5\%$ (Note 4) LTC1685C LTC1685I	● ●	26 20	30 25		MHz MHz

SWITCHING CHARACTERISTICS

Note 1: Absolute Maximum Ratings are those values beyond which the life of a device may be impaired.

Note 2: All currents into the device pins are positive; all currents out of the device pins are negative.

Note 3: All typicals are given for $V_{DD} = 5V$, $T_A = 25^\circ C$.

Note 4: Guaranteed by design, but not tested.

Note 5: Short-circuit current does not represent output drive capability. When the output detects a short-circuit condition, output drive current is significantly reduced (from hundreds of mA to 20mA max) until the short is removed.

TYPICAL PERFORMANCE CHARACTERISTICS

Receiver Input CMRR

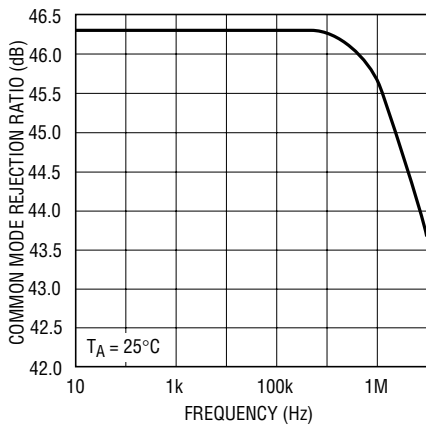

1685 G01

Supply Current vs Data Rate

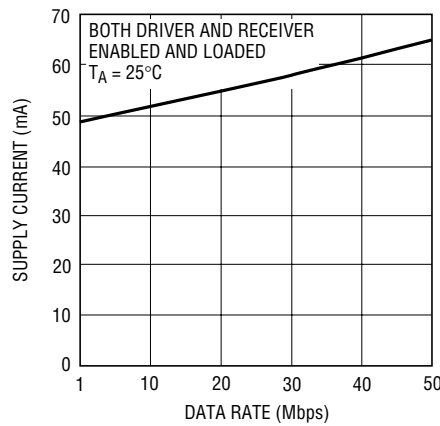

1685 G02

Supply Current vs Temperature

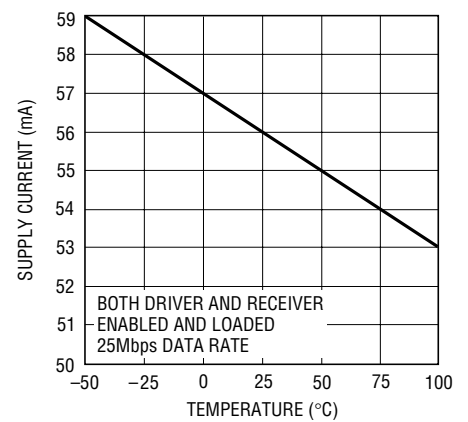

1685 G03

Receiver Propagation Delay vs Load Capacitance

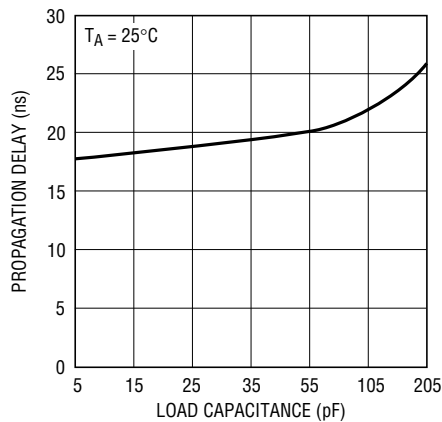

1685 G04

Receiver Propagation Delay vs Common Mode

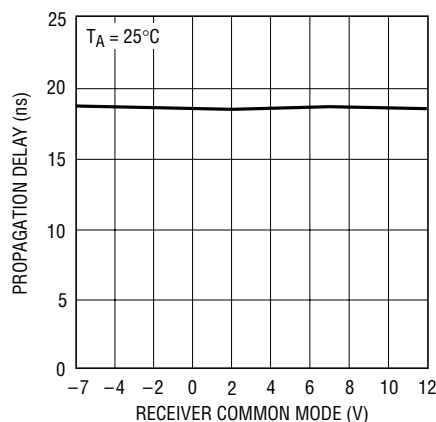

1685 G05

Receiver Propagation Delay vs Input Overdrive

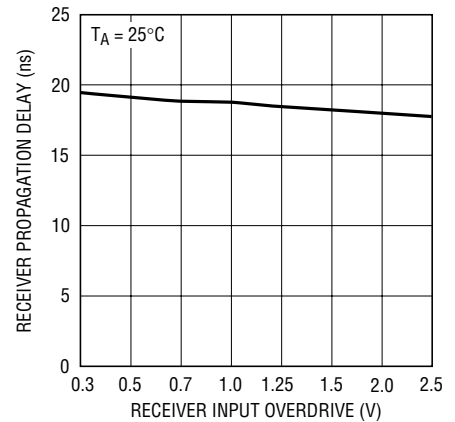

1685 G06

TYPICAL PERFORMANCE CHARACTERISTICS

Receiver Propagation Delay vs Temperature

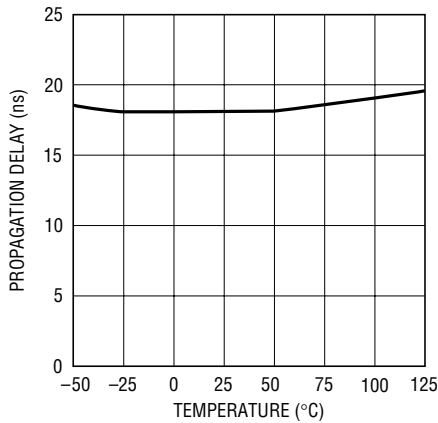

1680 G09

Receiver Maximum Data Rate vs Input Overdrive

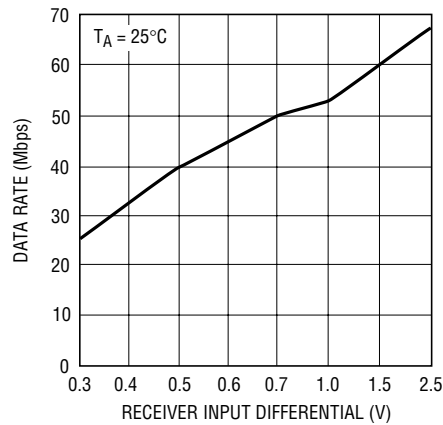

1685 G10

Driver Propagation Delay vs Temperature

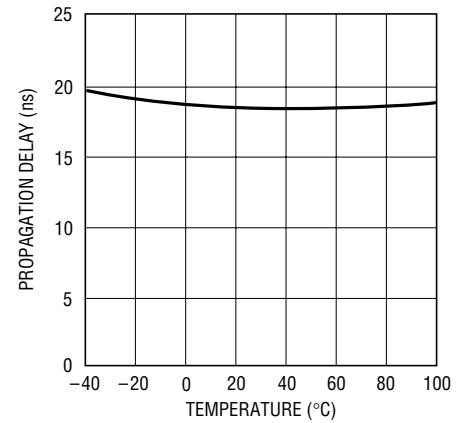

1685 G07

Driver Propagation Delay vs Driver Input Voltage

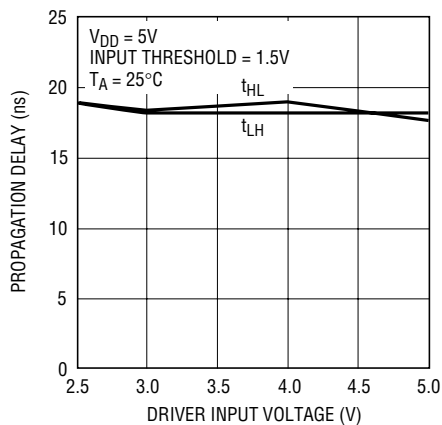

1685 G08

Driver Propagation Delay vs Capacitive Load

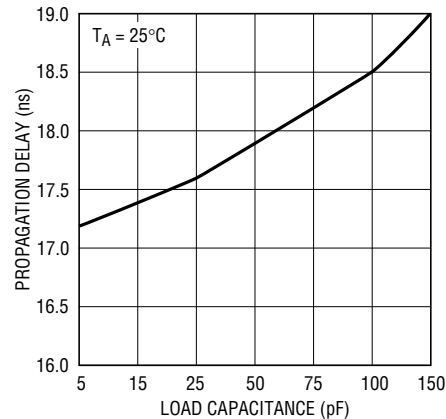

1685 G11

PIN FUNCTIONS

RO (Pin 1): Receiver Output. If $A \geq B$ by 300mV, then RO will be high. If $A \leq B$ by 300mV, then RO will be low.

\overline{RE} (Pin 2): Receiver Enable. $\overline{RE} = \text{Low}$ enables the receiver. $\overline{RE} = \text{High}$ forces receiver output into high impedance state. Do not float.

DE (Pin 3): Driver Enable. $DE = \text{High}$ enables the driver. $DE = \text{Low}$ will force the driver output into a high impedance state and the device will function as a line receiver if \overline{RE} is also low. Do not float.

DI (Pin 4): Driver Input. Controls the states of the A and B outputs only if $DE = \text{High}$. If $DE = \text{Low}$, DI will have no effect on A and B pins. Do not float.

GND (Pin 5): Ground.

A (Pin 6): Noninverting Receiver Input/Driver Output.

B (Pin 7): Inverting Receiver Input/Driver Output.

V_{DD} (Pin 8): Positive Supply, 5V to $\pm 5\%$. Bypass with 0.1 μF ceramic capacitor.

FUNCTION TABLES

Transmitting

\overline{RE}	INPUTS		LINE CONDITION	OUTPUTS	
	DE	DI		B	A
X	1	1	No Fault	0	1
X	1	0	No Fault	1	0
X	0	X	X	Hi-Z	Hi-Z
X	1	X	Fault	$\pm 10\text{mA}$ Current Source	

Receiving

INPUTS		A - B	OUTPUT RO
\overline{RE}	DE		
0	0	$\geq 300\text{mV}$	1
0	0	$\leq -300\text{mV}$	0
0	0	Inputs Open	1
0	0	Inputs Shorted Together A = B = -7V to 12V	1
1	X	X	Hi-Z

TEST CIRCUITS

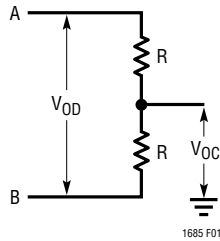

Figure 1. Driver DC Test Load

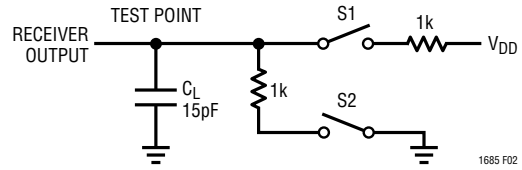

Figure 2. Driver DC Test Load

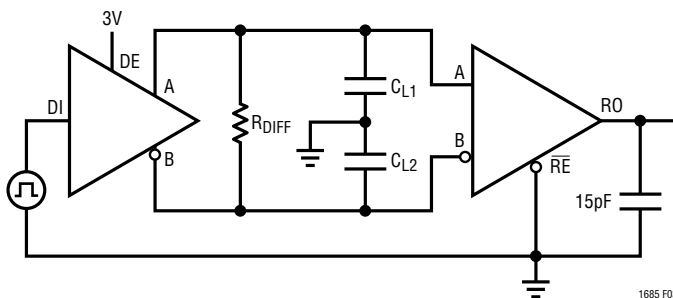

Figure 3. Driver/Receiver Timing Test Circuit

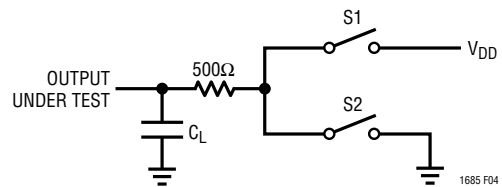

Figure 4. Driver Timing Test Load #2

SWITCHING TIME WAVEFORMS

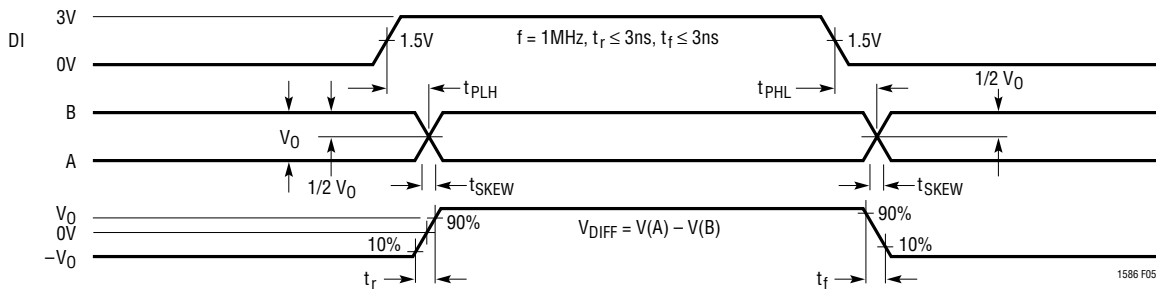

Figure 5. Driver Propagation Delays

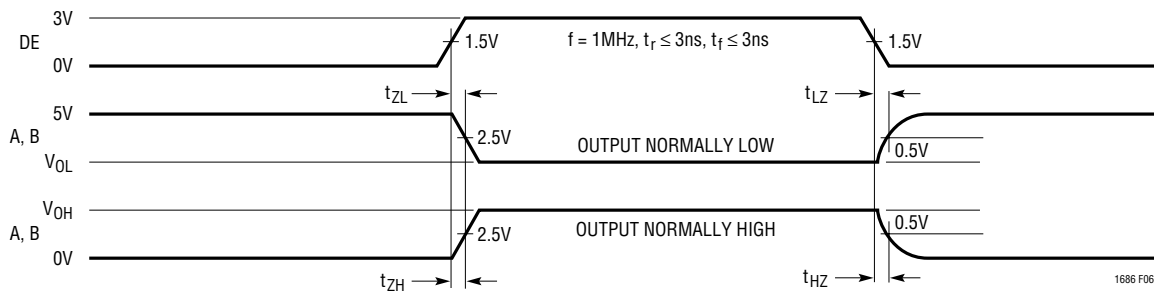

Figure 6. Driver Enable and Disable Times

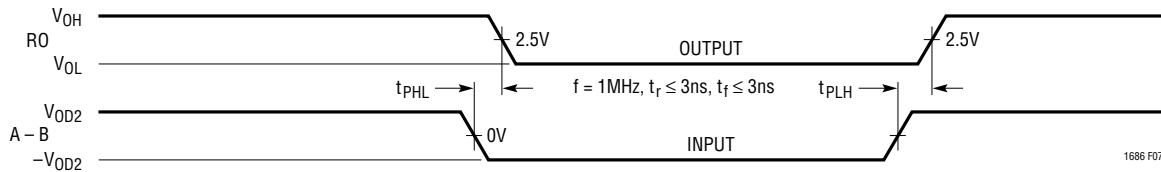

Figure 7. Receiver Propagation Delays

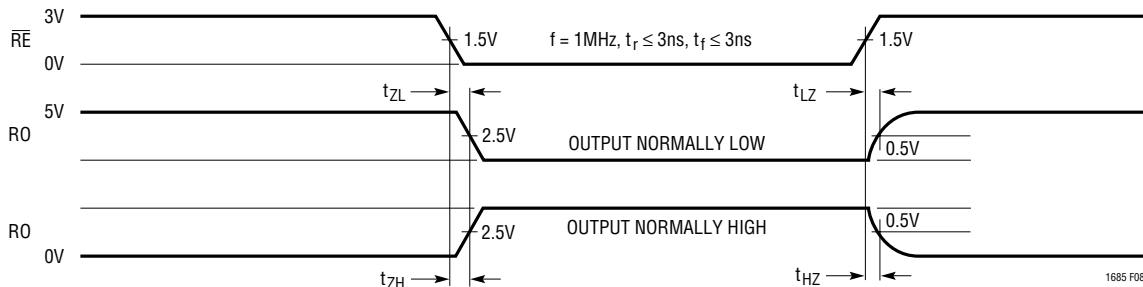

Figure 8. Receiver Enable and Disable Times

EQUIVALENT INPUT NETWORKS

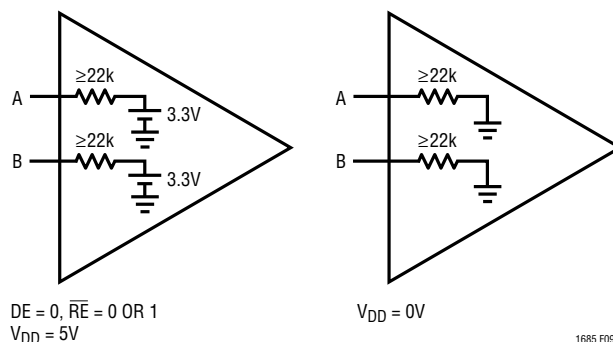

Figure 9. Input Thevenin Equivalent

APPLICATIONS INFORMATION

Theory of Operation

Unlike typical CMOS transceivers whose propagation delay can vary by as much as 500% from package to package and show significant temperature drift, the LTC1685 employs a novel architecture that produces a tightly controlled and temperature compensated propagation delay. The differential timing skew is also minimized between rising and falling output edges of the receiver output and the complementary driver outputs.

The precision timing features of the LTC1685 reduce overall system timing constraints by providing a narrow $\pm 3.5\text{ns}$ window during which valid data appears at the receiver/driver output. The driver and receiver pair will have propagation delays that typically match to within 1ns.

In clocked data systems, the low skew minimizes duty cycle distortion of the clock signal. The LTC1685 can be used at data rates of 52Mbps with less than 5% duty cycle distortion (depending on cable length). When a clock signal is used to retime parallel data, the maximum recommended data transmission rate is 26Mbps to avoid timing errors due to clock distortion.

Fail-Safe Features

The LTC1685 has a fail-safe feature that guarantees the receiver output to be in a logic HIGH state when the inputs are either shorted or left open (note that when inputs are left open, large external leakage currents might override the fail-safe circuitry). In order to maintain good high frequency performance, it was necessary to slow down the transient response of the fail-safe feature. When a line fault is detected, the output will go HIGH typically in $2\mu\text{s}$. **Note that the LTC1685 guarantees fail-safe performance over the *entire* (–7V to 12V) common mode range!**

When the inputs are accidentally shorted (by cutting through a cable, for example), the short circuit fail-safe feature will guarantee a high output logic level. Note also that if the line driver is removed and the termination resistors are left in place, the receiver will see this as a “short” and output a logic HIGH. Both of these fail-safe features will keep the receiver from outputting false data pulses under line fault conditions.

Thermal shutdown and short-circuit protection prevent latchup damage to the LTC1685 during fault conditions.

APPLICATIONS INFORMATION

Output Short-Circuit Protection

The LTC1685 employs voltage sensing short-circuit protection at the output terminals of both the driver and receiver. For a given input polarity, this circuitry determines what the correct output level should be. If the output level is different from the expected, it shuts off the big output devices. For example, if the driver input is $>2V$, it expects the “A” output to be $>3.25V$ and the “B” output to be $<1.75V$. If the “A” output is subsequently shorted to a voltage below $V_{DD}/2$, this circuitry shuts off the big output devices and turns on a smaller device in its place (the converse applies for the “B” output). The outputs then appear as $\pm 10mA$ current sources. Note that under normal operation, the output drivers can sink/source $>50mA$. A time-out period of about $50ns$ is used in order to maintain normal high frequency operation, even under heavy capacitive loads.

If the cable is shorted at a large distance from the device outputs, it is possible for the short to go unnoticed at the driver outputs due to parasitic cable resistance. Additionally, when the cable is shorted, it no longer appears as an ideal transmission line, and the parasitic L_s and C_s might give rise to ringing and even oscillation. All these conditions disappear once the device comes out of short-circuit mode.

For cables with the typical RS485 termination (no DC bias on the cable, such as Figure 10), the LTC1685 will automatically come out of short-circuit mode once the physical short has been removed. With cable terminations with a DC bias (such as Fast-20 and Fast-40 differential SCSI

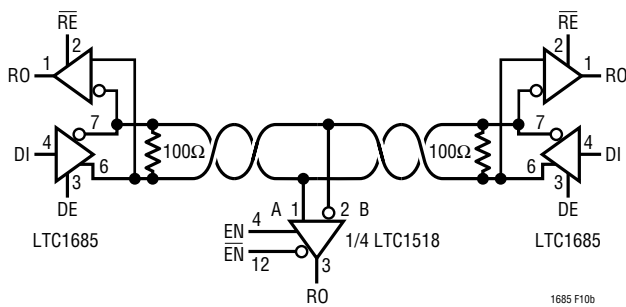

Figure 10

terminators, see Figure 15), the LTC1685 will *not* come out of short-circuit mode automatically upon release of the physical short. In order to resume normal operation, the DE pin has to be pulsed low for at least $200ns$.

High Speed Twisted Pair Transmission

Data rates up to $52Mbps$ can be transmitted over $100ft$ of category 5 twisted pair. Figure 10 shows the LTC1685 receiving differential data from another LTC1685 transceiver. Figure 11a shows a $26MHz$ ($52Mbps$) square wave propagated over $100ft$ of category 5 UTP. Figure 11b shows a more stringent case of propagating a single $20ns$ pulse over $100ft$ of category 5 UTP. Figure 12 shows a $4Mbps$ square wave over $1000ft$ of category 5 unshielded twisted pair.

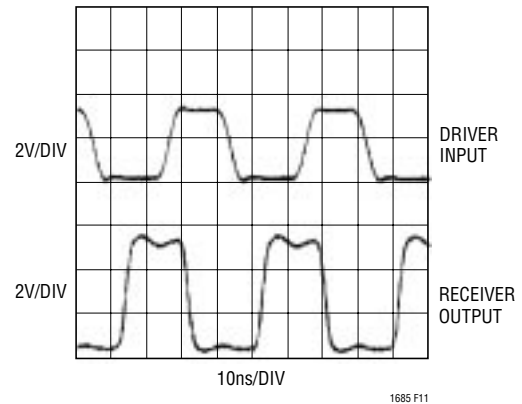

Figure 11a. 100ft of Category 5 UTP: 50Mbps

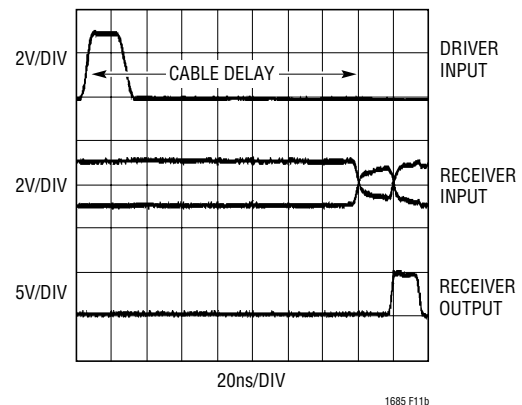

Figure 11b. 100ft of Category 5 UTP: 20ns Pulse

APPLICATIONS INFORMATION

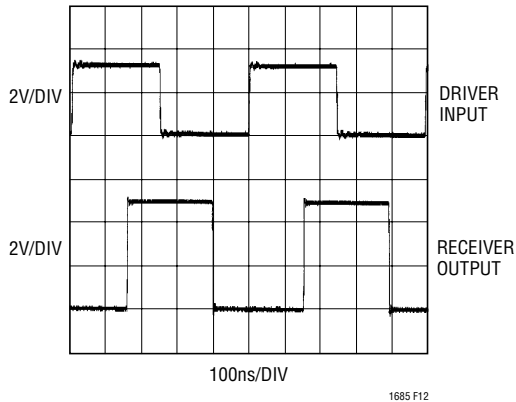

Figure 12. 1000ft of Category 5 UTP: 4Mbps

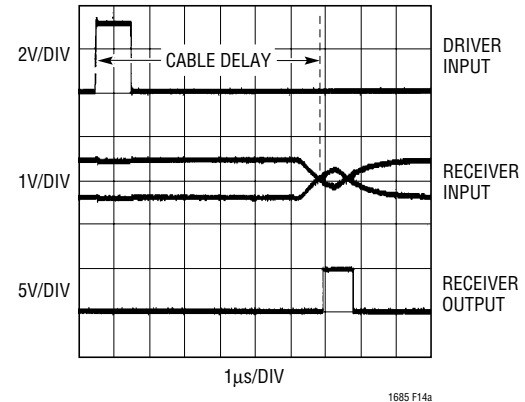

Figure 14a. 4000ft of Category 5 UTP: 1µs Pulse

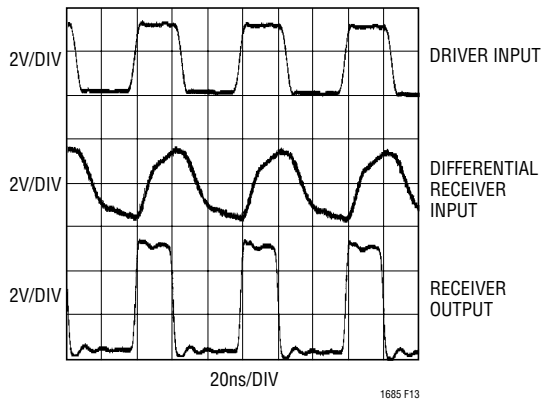

Figure 13. 100ft of Telephone Grade UTP: 30Mbps

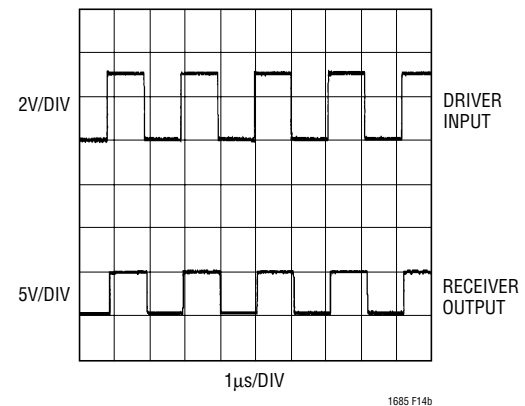

Figure 14b. 4000ft of Category 5 UTP: 1Mbps Square Wave

Very inexpensive unshielded telephone grade twisted pair is shown in Figure 13. In spite of the noticeable loss at the receiver input, the LTC1685 can still transfer 30Mbps at 100ft of telephone grade UTP. Note that under all these conditions, the LTC1685 can pass through a single data pulse equal to the inverse of the data rate (e.g., 20ns for 50Mbps data rate).

Even at distances of 4000ft, 1Mbps data rates are possible using the LTC1685 and category 5 UTP. Figure 14a shows a 1µs pulse propagated down 4000ft of category 5 UTP. Notice both the DC and the AC losses at the receiver input. The DC attenuation is due to the parasitic resistance of the cable. Figure 14b shows a 1Mbps square wave over 4000ft. To transmit at this speed but using longer cable lengths, see the LTC1686/LTC1687 high speed RS485 full-duplex transceivers.

High Speed Backplane Transmission

The LTC1685 can also be used in backplane point-to-point transceiver applications, where the user wants to assure operation even when the common mode goes above or below the rails. It is advisable to terminate the PC traces when approaching maximum speeds. Since the LTC1685 is not intended to drive parallel terminated cables with characteristic impedances much less than that of twisted pair, both ends of the PC trace must be *series terminated* with the characteristic impedance of the trace. For best results, the signal should be routed differentially. The true and complement outputs of the LTC1685 should be routed on adjacent layers of the PC board. The two traces should be routed very symmetrically, minimizing and equalizing parasitics to nearby signal and power/ground layers. For single-ended transmission, route the series terminated

APPLICATIONS INFORMATION

single-ended trace over an adjacent ground plane. Then set the (bypassed) negative input of the receiver to roughly 2.5V. Note that single-ended operation might not reach maximum speeds.

High Speed Differential SCSI (Fast-20, Fast-40 HVD)

The LTC1685's high speed, tight propagation delay window and matched driver/receiver propagation delays make it a natural choice as the external transceiver in high speed differential SCSI applications. Note that the $\pm 3.5\text{ns}$ propagation delay window covers the entire commercial temperature range. If, for example, a group of 16 transceivers is placed on the same board, their temperature difference will be much smaller. Hence, the difference in their propagation delays should be even better than the $\pm 3.5\text{ns}$ specification (typically better than $\pm 2\text{ns}$). The LTC1685 is the most efficient and reliable implementation that meets the Fast-20 and Fast-40 HVD driver and receiver skew specifications.

Power-Up Requirements

The LTC1685 has unique short-circuit protection that shuts off the big output devices (and keeps them off) when a short is detected. When the LTC1685 is powered up with the driver outputs enabled (Figure 15 shows a typical connection), the part will power up in short-circuit mode. After power-up, the user must hold the DE pin of the LTC1685 low for at least 200ns in order to start normal operation. Note also that turning the termination power on/off might induce the LTC1685 to see a "short." Consequently, the DE pin should be held low for 200ns after cable termination power is turned on.

This requirement is solely due to the cable termination (the 165Ω parallel resistance to both power and ground). For applications whose connections to the cable are made exclusively with RS485 devices, the cable can be terminated *only* across the two signal wires (as in Figure 10). With cable distances covering under 25 meters, the common mode range of the LTC1685 should be more than sufficient to account for any ground differences between any two communicating devices. The fact that transmission is differential should greatly improve noise

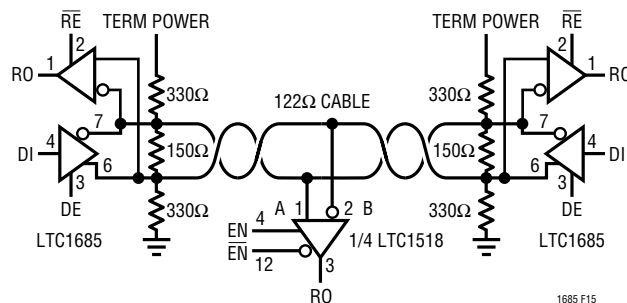

Figure 15. Fast-20, Fast-40 Differential SCSI Application

margin. Furthermore, the good high frequency CMRR of the receiver will serve to reject any common mode interference.

DE, DI Inputs

It is not necessary that the driver input (DI) have 0V to 3V signal levels. The DI input can be driven by CMOS levels (0V to 5V) and still achieve 40Mbps operation. However, duty cycle will be slightly compromised when driven by a CMOS device. Care should be taken to minimize the ringing on the DI input in order to achieve a driver propagation delay within the $\pm 3.5\text{ns}$ window. This also improves the package-to-package matching of propagation delays.

The DE pin should be held low for 200ns after the power-up sequence has been completed. After fault conditions such as an output short or thermal shutdown, the DE pin should be held low for at least 200ns after the fault has been removed. This is usually necessary only if the driver outputs are connected to DC-biased cable terminations (as in Figure 15).

Layout Considerations

A ground plane is recommended when using a high frequency device like the LTC1685. A $0.1\mu\text{F}$ ceramic bypass capacitor less than 1/4 inch away from the V_{DD} pin is recommended. Good bypassing is especially needed when operating at maximum frequency or when package-to-package matching is very important. The PC board traces connected to the "A" and "B" outputs must be kept as symmetrical and short as possible to obtain the same

APPLICATIONS INFORMATION

parasitic board capacitance. This maintains the good matching characteristics of the low-to-high and high-to-low transitions of the LTC1685. Note that output “A” to output “B” capacitance should also be minimized. If routed adjacent to each other on the same layer, they should be separated by an amount at least as wide as the trace widths. If output “A” and output “B” are routed on different signal planes, they should not be routed directly on top of

each other. A trace width’s lateral separation is also recommended.

As mentioned before, care should also be taken when routing the “DI” input. To achieve consistent board-to-board propagation delay, the ringing on this signal should be kept below a few hundred millivolts.

PACKAGE DESCRIPTION Dimensions in inches (millimeters) unless otherwise noted.

S8 Package
8-Lead Plastic Small Outline (Narrow 0.150)
 (LTC DWG # 05-08-1610)

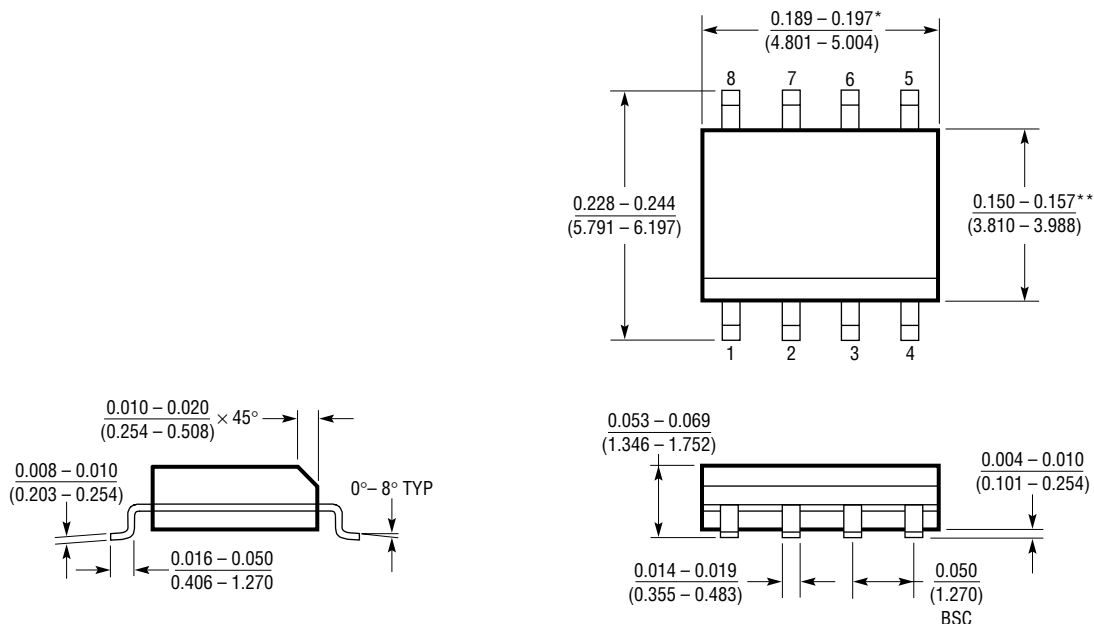

* DIMENSION DOES NOT INCLUDE MOLD FLASH. MOLD FLASH SHALL NOT EXCEED 0.006" (0.152mm) PER SIDE
 ** DIMENSION DOES NOT INCLUDE INTERLEAD FLASH. INTERLEAD FLASH SHALL NOT EXCEED 0.010" (0.254mm) PER SIDE

S08 0695

RELATED PARTS

PART NUMBER	DESCRIPTION	COMMENTS
LTC1485	High Speed RS485 Transceiver	10Mbps, Pin Compatible with LTC485
LTC1518/LTC1519	High Speed Quad RS485 Receivers	52Mbps, Pin Compatible with LTC488/LTC489
LTC1520	High Speed Quad Differential Receiver	52Mbps, $\pm 100\text{mV}$ Threshold, Rail-to-Rail Common Mode
LTC1686/LTC1687	High Speed RS485 Driver/Receiver	52Mbps, Pin Compatible with LTC490/LTC491
LTC1688/LTC1689	High Speed Quad RS485 Drivers	100Mbps, Pin Compatible with LTC486/LTC487

Looking for pricing, stock, or lifecycle information?

Click below to explore more details on WIN SOURCE:

- ⊖ [View LTC1685CS8#PBF on WIN SOURCE](#)
- ⊖ [Linear Technology Information](#)

Optimize Your Supply Chain with WIN SOURCE Solutions

- ✓ Global Sourcing Solution
- ✓ Obsolete Management
- ✓ Cost Control Management
- ✓ Shortage Management
- ✓ Alternative Solution
- ✓ Excess Inventory Management