



**THE DATASHEET OF
LTC1707CS8#TRPBF**



High Efficiency Monolithic Synchronous Step-Down Switching Regulator

FEATURES

- 600mA Output Current ($V_{IN} \geq 4V$)
- High Efficiency: Up to 96%
- Constant Frequency: 350kHz Synchronizable to 550kHz
- 2.85V to 8.5V V_{IN} Range
- 0.8V Feedback Reference Allows Low Voltage Outputs: $0.8V \leq V_{OUT} \leq V_{IN}$
- No Schottky Diode Required
- 1.19V $\pm 1\%$ Reference Output Pin
- Selectable Burst Mode™ Operation/Pulse Skipping Mode
- Low Dropout Operation: 100% Duty Cycle
- Precision 2.7V Undervoltage Lockout
- Current Mode Control for Excellent Line and Load Transient Response
- Low Quiescent Current: 200 μ A
- Shutdown Mode Draws Only 11 μ A Supply Current
- Available in 8-Lead SO Package

APPLICATIONS

- Cellular Telephones
- Portable Instruments
- Wireless Modems
- RF Communications
- Distributed Power Systems
- Single and Dual Cell Lithium

DESCRIPTION

The LTC[®]1707 is a high efficiency monolithic current mode synchronous buck regulator using a fixed frequency architecture. The operating supply range is from 8.5V down to 2.85V, making it suitable for both single and dual lithium-ion battery-powered applications. Burst Mode operation provides high efficiency at low load currents. 100% duty cycle provides low dropout operation, extending operating time in battery-powered systems.

The switching frequency is internally set at 350kHz, allowing the use of small surface mount inductors. For noise sensitive applications it can be externally synchronized up to 550kHz. Burst Mode operation is inhibited during synchronization or when the SYNC/MODE pin is pulled low preventing low frequency ripple from interfering with audio circuitry. Soft-start is provided by an external capacitor.

The internal synchronous MOSFET switch increases efficiency and eliminates the need for an external Schottky diode, saving components and board space. Low output voltages down to 0.8V are easily achieved due to the 0.8V internal reference. The LTC1707 comes in an 8-lead SO package.

LT, LTC and LT are registered trademarks of Linear Technology Corporation. Burst Mode is a trademark of Linear Technology Corporation.

TYPICAL APPLICATION

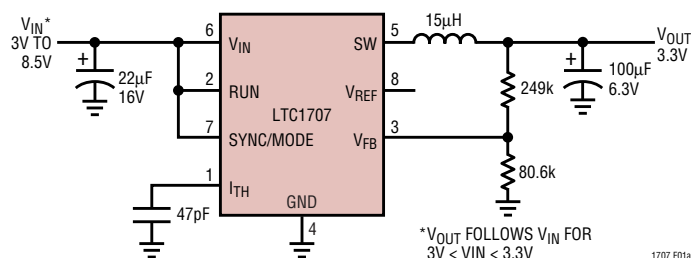

Figure 1a. High Efficiency Low Dropout Step-Down Converter

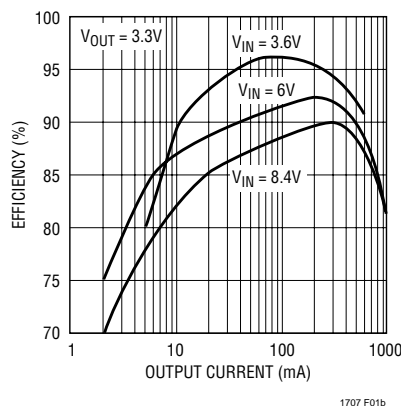

Figure 1b. Efficiency vs Output Load Current

ABSOLUTE MAXIMUM RATINGS

(Note 1)

Input Supply Voltage	-0.3V to 10V
I_{TH} Voltage	-0.3V to 5V
RUN/SS, V_{FB} Voltages	-0.3V to V_{IN}
SYNC/MODE Voltage	-0.3V to V_{IN}
P-Channel Switch Source Current (DC)	800mA
N-Channel Switch Sink Current (DC)	800mA
Peak SW Sink and Source Current	1.5A
Operating Ambient Temperature Range	
Commercial	0°C to 70°C
Industrial	-40°C to 85°C
Junction Temperature (Note 2)	125°C
Storage Temperature Range	-65°C to 150°C
Lead Temperature (Soldering, 10 sec)	300°C

PACKAGE/ORDER INFORMATION

<p>TOP VIEW</p> <p>S8 PACKAGE 8-LEAD PLASTIC SO $T_{JMAX} = 125^{\circ}C, \theta_{JA} = 120^{\circ}C/W$</p>	ORDER PART NUMBER
	LTC1707CS8 LTC1707IS8
	S8 PART MARKING
	1707 1707I

Consult factory for Military grade parts.

ELECTRICAL CHARACTERISTICS

The ● denotes specifications which apply over the full operating temperature range, otherwise specifications are at $T_A = 25^{\circ}C$. $V_{IN} = 5V$ unless otherwise specified.

SYMBOL	PARAMETER	CONDITIONS	MIN	TYP	MAX	UNITS
I_{VFB}	Feedback Current	(Note 3)		6	60	nA
V_{FB}	Regulated Feedback Voltage	(Note 3) ●	0.78	0.80	0.82	V
ΔV_{OVL}	Output Overvoltage Lockout	$\Delta V_{OVL} = V_{OVL} - V_{FB}$	20	60	110	mV
ΔV_{FB}	Reference Voltage Line Regulation	$V_{IN} = 3V$ to $8.5V$ (Note 3)		0.002	0.01	%/V
$V_{LOADREG}$	Output Voltage Load Regulation	I_{TH} Sinking $2\mu A$ (Note 3) I_{TH} Sourcing $2\mu A$ (Note 3)		0.5	0.8	%
I_S	Input DC Bias Current	(Note 4)		300		μA
	Pulse Skipping Mode	$V_{IN} = 8.5V, V_{OUT} = 3.3V, V_{SYNC/MODE} = 0V$		200	320	μA
	Burst Mode Operation	$V_{ITH} = 0V, V_{IN} = 8.5V, V_{SYNC/MODE} = \text{Open}$		11	35	μA
	Shutdown	$V_{RUN/SS} = 0V, 3V < V_{IN} < 8.5V$		6		μA
	Shutdown	$V_{RUN/SS} = 0V, V_{IN} < 3V$				μA
$V_{RUN/SS}$	Run/SS Threshold	$V_{RUN/SS}$ Ramping Positive	0.4	0.7	1.0	V
$I_{RUN/SS}$	Soft-Start Current Source	$V_{RUN/SS} = 0V$	1.2	2.25	3.3	μA
$I_{SYNC/MODE}$	SYNC/MODE Pull-Up Current	$V_{SYNC/MODE} = 0V$	0.5	1.5	2.5	μA
f_{OSC}	Oscillator Frequency	$V_{FB} = 0.7V$ $V_{FB} = 0V$	315	350	385	kHz
V_{UVLO}	Undervoltage Lockout	V_{IN} Ramping Down from $3V$ ($0^{\circ}C$ to $70^{\circ}C$)	2.55	2.70	2.85	V
		V_{IN} Ramping Up from $0V$ ($0^{\circ}C$ to $70^{\circ}C$)	2.60	2.80	3.00	V
		V_{IN} Ramping Down from $3V$ ($-40^{\circ}C$ to $85^{\circ}C$)	2.45	2.70	2.85	V
		V_{IN} Ramping Up from $0V$ ($-40^{\circ}C$ to $85^{\circ}C$)	2.50	2.80	3.00	V
R_{PFET}	$R_{DS(ON)}$ of P-Channel FET	$I_{SW} = -100mA$		0.5	0.7	Ω
R_{NFET}	$R_{DS(ON)}$ of N-Channel FET	$I_{SW} = -100mA$		0.6	0.8	Ω
I_{PK}	Peak Inductor Current	$V_{IN} = 4V, I_{TH} = 1.4V, \text{Duty Cycle} < 40\%$	0.70	0.915	1.10	A
I_{LSW}	SW Leakage	$V_{RUN/SS} = 0V$		± 10	± 1000	nA
V_{REF}	Reference Output Voltage	$I_{REF} = 0\mu A$ ●	1.178	1.19	1.202	mV
ΔV_{REF}	Reference Output Load Regulation	$0V \leq I_{REF} \leq 100\mu A$ ●		2.3	15	mV

Note 1: Absolute Maximum Ratings are those values beyond which the life of a device may be impaired.

Note 2: T_J is calculated from the ambient temperature T_A and power dissipation P_D according to the following formula:

$$T_J = T_A + (P_D \cdot 110^{\circ}C/W)$$

Note 3: The LTC1707 is tested in a feedback loop that servos V_{FB} to the balance point for the error amplifier ($V_{ITH} = 0.8V$).

Note 4: Dynamic supply current is higher due to the gate charge being delivered at the switching frequency.

TYPICAL PERFORMANCE CHARACTERISTICS

Efficiency vs Input Voltage

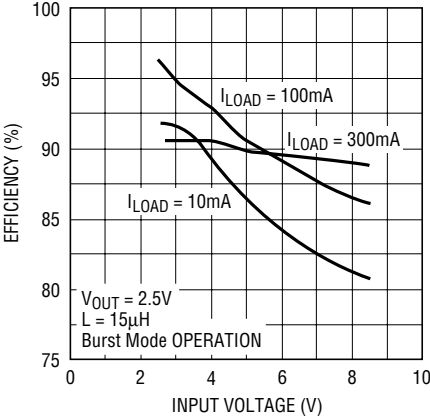

1707 G01

Efficiency vs Load Current

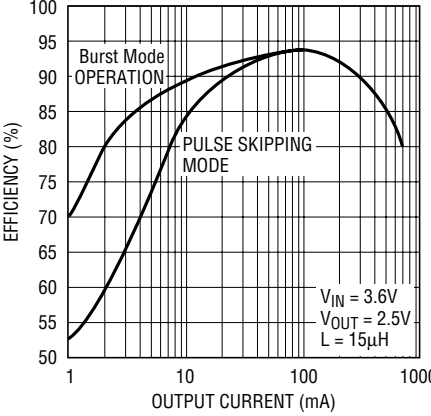

1707 G02

Efficiency vs Load Current

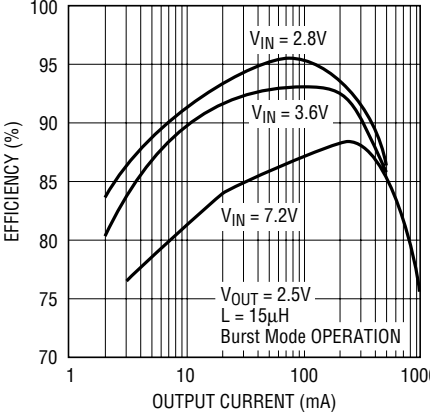

1707 G03

Undervoltage Lockout Threshold vs Temperature

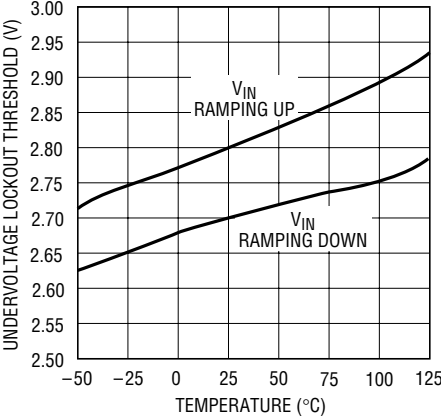

1707 G04

DC Supply Current vs Input Voltage

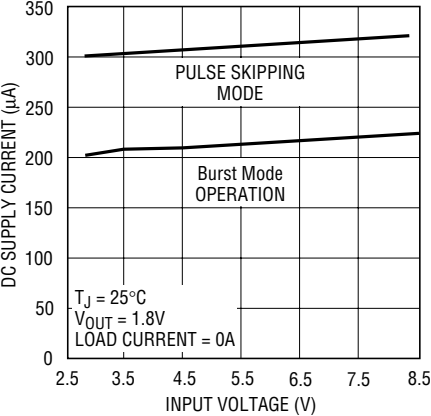

1707 G05

Supply Current in Shutdown vs Input Voltage

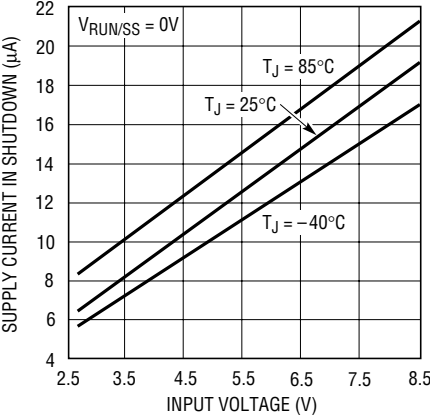

1707 G06

Reference Voltage vs Temperature

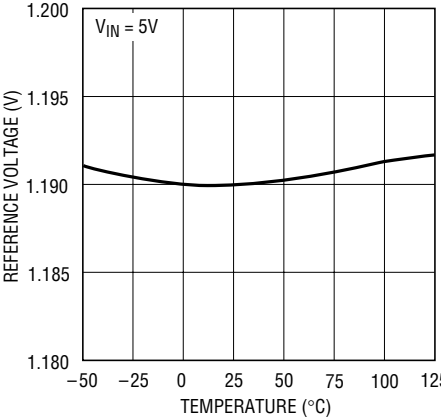

1707 G07

Oscillator Frequency vs Temperature

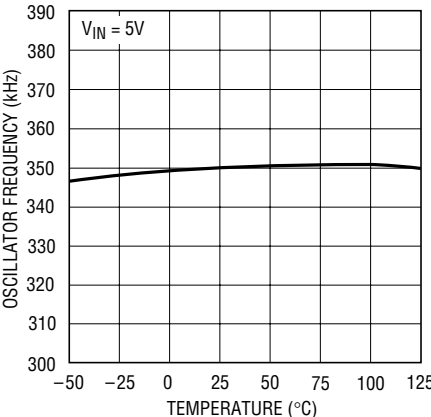

1707 G08

Oscillator Frequency vs Input Voltage

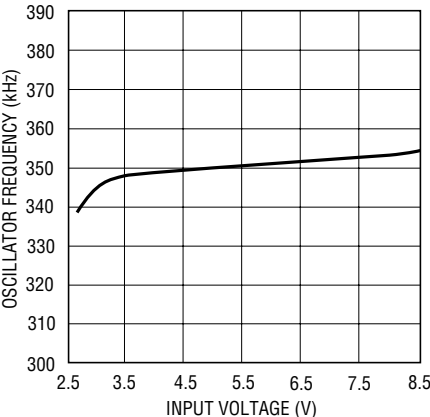

1627 G09

TYPICAL PERFORMANCE CHARACTERISTICS

Maximum Output Current vs Input Voltage

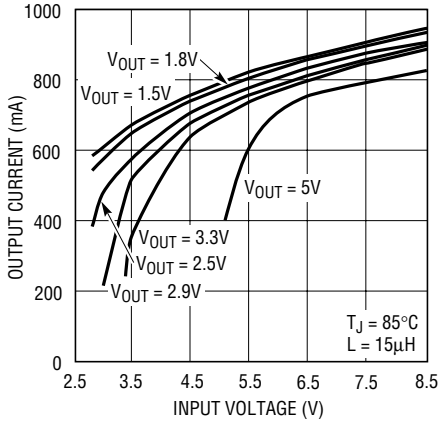

1707 G10

Switch Leakage Current vs Temperature

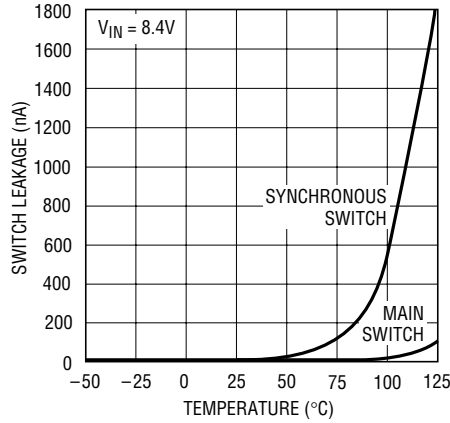

1707 G11

Switch Resistance vs Temperature

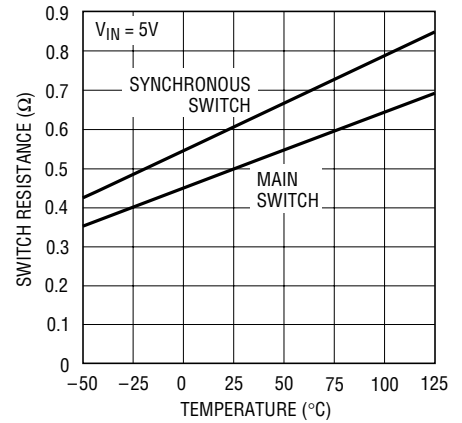

1707 G12

Switch Resistance vs Input Voltage

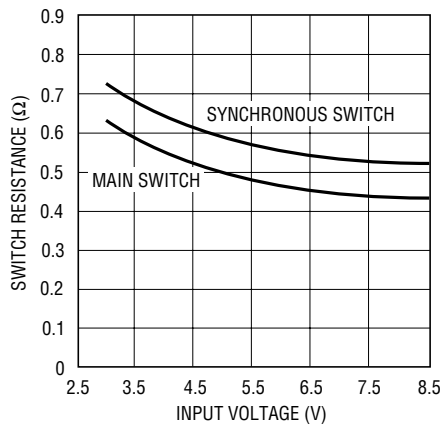

1707 G13

Load Step Transient Response

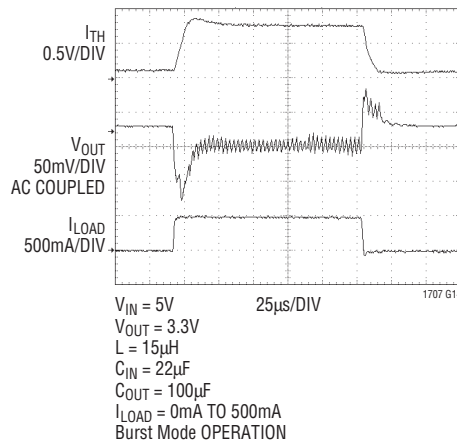

1707 G14

Burst Mode Operation

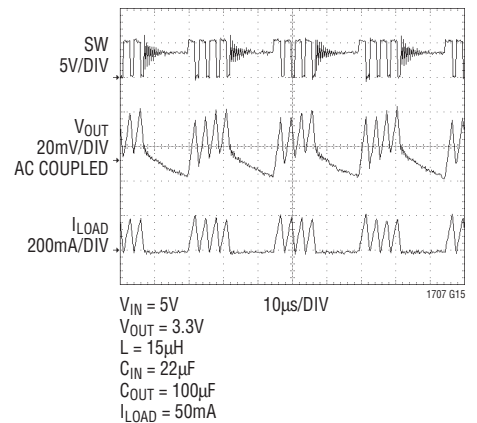

1707 G15

PIN FUNCTIONS

I_{TH} (Pin 1): Error Amplifier Compensation Point. The current comparator threshold increases with this control voltage. Nominal voltage range for this pin is 0V to 1.2V.

RUN/SS (Pin 2): Combination of Soft-Start and Run Control Inputs. A capacitor to ground at this pin sets the ramp time to full current output. The time is approximately $0.5s/\mu F$. Forcing this pin below 0.4V shuts down the LTC1707.

V_{FB} (Pin 3): Feedback Pin. Receives the feedback voltage from an external resistive divider across the output.

GND (Pin 4): Ground Pin.

SW (Pin 5): Switch Node Connection to Inductor. This pin connects to the drains of the internal main and synchronous power MOSFET switches.

V_{IN} (Pin 6): Main Supply Pin. Must be closely decoupled to GND, Pin 4.

SYNC/MODE (Pin 7): This pin performs two functions: 1) synchronize with an external clock and 2) select between two modes of low load current operation. To synchronize with an external clock, apply a TTL/CMOS compatible clock with a frequency between 385kHz and 550kHz. To select Burst Mode operation, float the pin or tie it to V_{IN} . Grounding Pin 7 forces pulse skipping mode operation.

V_{REF} (Pin 8): The Output of a $1.19V \pm 1\%$ Precision Reference. May be loaded up to $100\mu A$ and is stable with up to $2000pF$ load capacitance.

FUNCTIONAL DIAGRAM

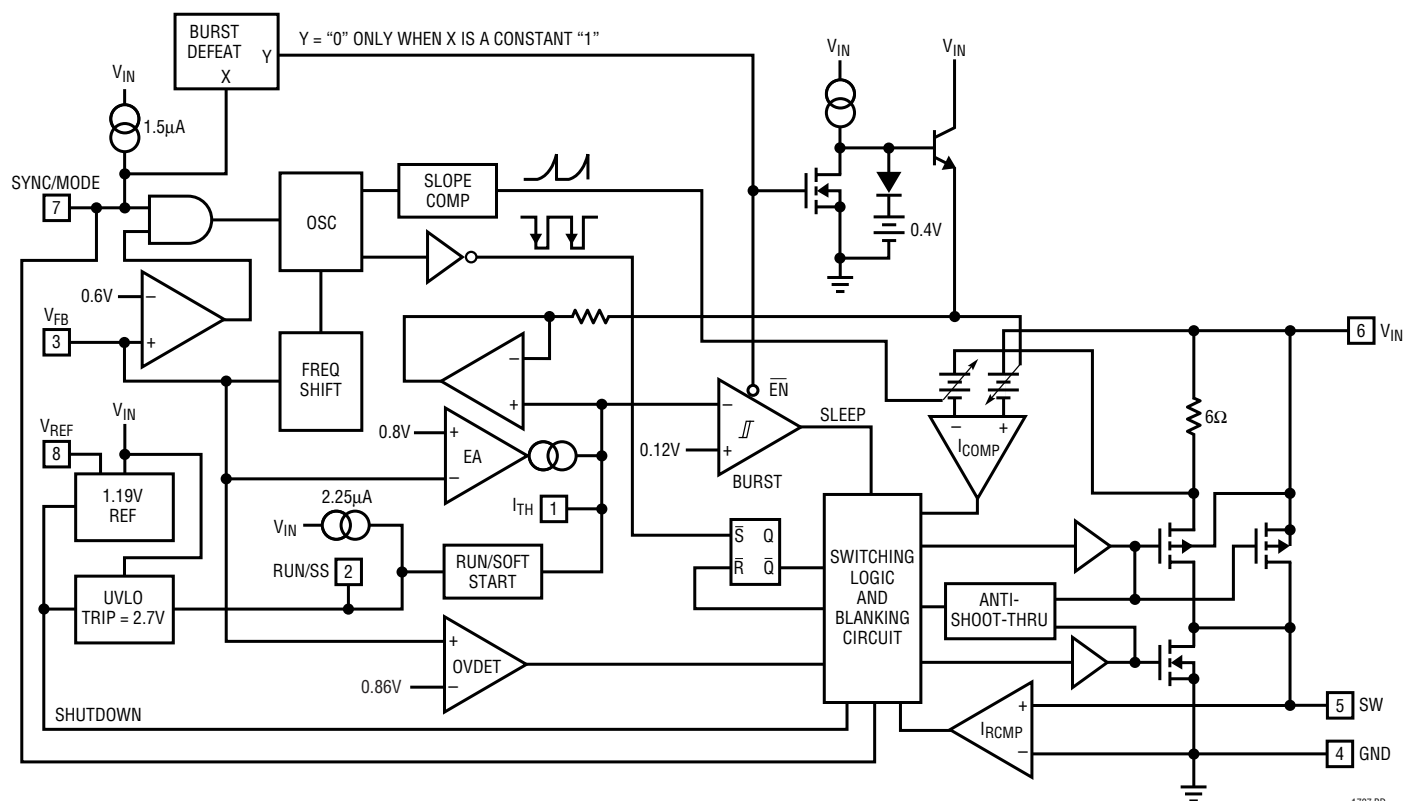

1707 BD

OPERATION (Refer to Functional Diagram)

Main Control Loop

The LTC1707 uses a constant frequency, current mode step-down architecture. Both the main (P-channel MOSFET) and synchronous (N-channel MOSFET) switches are internal. During normal operation, the internal top power MOSFET is turned on each cycle when the oscillator sets the RS latch, and turned off when the current comparator, I_{COMP} , resets the RS latch. The peak inductor current at which I_{COMP} resets the RS latch is controlled by the voltage on the I_{TH} pin, which is the output of error amplifier EA. The V_{FB} pin, described in the Pin Functions section, allows EA to receive an output feedback voltage from an external resistive divider. When the load current increases, it causes a slight decrease in the feedback voltage relative to the 0.8V reference, which, in turn, causes the I_{TH} voltage to increase until the average inductor current matches the new load current. While the top MOSFET is off, the bottom MOSFET is turned on until either the inductor current starts to reverse as indicated by the current reversal comparator I_{RCMP} , or the beginning of the next cycle.

The main control loop is shut down by pulling the RUN/SS pin low. Releasing RUN/SS allows an internal 2.25 μ A current source to charge soft-start capacitor C_{SS} . When C_{SS} reaches 0.7V, the main control loop is enabled with the I_{TH} voltage clamped at approximately 5% of its maximum value. As C_{SS} continues to charge, I_{TH} is gradually released, allowing normal operation to resume.

Comparator OVDET guards against transient overshoots >7.5% by turning the main switch off and keeping it off until the fault is removed.

Burst Mode Operation

The LTC1707 is capable of Burst Mode operation in which the internal power MOSFETs operate intermittently based on load demand. To enable Burst Mode operation, simply allow the SYNC/MODE pin to float or connect it to a logic high. To disable Burst Mode operation and enable pulse skipping mode, connect the SYNC/MODE pin to GND. In this mode, efficiency is lower at light loads, but becomes comparable to Burst Mode operation when the output load exceeds 30mA.

When the converter is in Burst Mode operation, the peak current of the inductor is set to approximately 200mA, even though the voltage at the I_{TH} pin indicates a lower value. The voltage at the I_{TH} pin drops when the inductor's average current is greater than the load requirement. As the I_{TH} voltage drops below 0.12V, the BURST comparator trips, causing the internal sleep line to go high and forcing off both internal power MOSFETs.

In sleep mode, both power MOSFETs are held off and the internal circuitry is partially turned off, reducing the quiescent current to 200 μ A. The load current is now being supplied from the output capacitor. When the output voltage drops, causing I_{TH} to rise above 0.22V, the top MOSFET is again turned on and this process repeats.

Short-Circuit Protection

When the output is shorted to ground, the frequency of the oscillator is reduced to about 35kHz, 1/10 the nominal frequency. This frequency foldback ensures that the inductor current has more time to decay, thereby preventing runaway. The oscillator's frequency will progressively increase to 350kHz (or the synchronized frequency) when V_{FB} rises above 0.3V.

Frequency Synchronization

The LTC1707 can be synchronized with an external TTL/CMOS compatible clock signal with an amplitude of at least 2V_{P-P}. The frequency range of this signal must be from 385kHz to 550kHz. *Do not* attempt to synchronize the LTC1707 below 385kHz as this may cause abnormal operation and an undesired frequency spectrum. The top MOSFET turn-on follows the rising edge of the external source.

When the LTC1707 is synchronized to an external source, the LTC1707 operates in PWM pulse skipping mode. In this mode, when the output load is very low, current comparator I_{COMP} remains tripped for more than one cycle and forces the main switch to stay off for the same number of cycles. Increasing the output load slightly allows constant frequency PWM operation to resume. This mode exhibits low output ripple as well as low audio noise and reduced RF interference while providing reasonable low current efficiency.

OPERATION

Frequency synchronization is inhibited when the feedback voltage V_{FB} is below 0.6V. This prevents the external clock from interfering with the frequency foldback for short-circuit protection.

Dropout Operation

When the input supply voltage decreases toward the output voltage, the duty cycle increases toward the maximum on-time. Further reduction of the supply voltage forces the main switch to remain on for more than one cycle until it reaches 100% duty cycle. The output voltage will then be determined by the input voltage minus the voltage drop across the P-channel MOSFET and the inductor.

In Burst Mode operation or pulse skipping mode operation with the output lightly loaded, the LTC1707 transitions through continuous mode as it enters dropout.

Undervoltage Lockout

A precision undervoltage lockout shuts down the LTC1707 when V_{IN} drops below 2.7V, making it ideal for single lithium-ion battery applications. In lockout, the LTC1707 draws only several microamperes, which is low enough to prevent deep discharge and possible damage to the lithium-ion battery nearing its end of charge. A 100mV hysteresis ensures reliable operation with noisy input supplies.

Low Supply Operation

The LTC1707 is designed to operate down to a 2.85V input voltage. At this voltage the converter is most likely to be running at high duty cycles or in dropout where the main

switch is on continuously. Hence, the I^2R loss is due mainly to the $R_{DS(ON)}$ of the P-channel MOSFET. See Efficiency Considerations in the Applications Information section.

Below $V_{IN} = 4V$, the output current must be derated as shown in Figures 2a and 2b. For applications that require 500mA below $V_{IN} = 4V$, select the LTC1627.

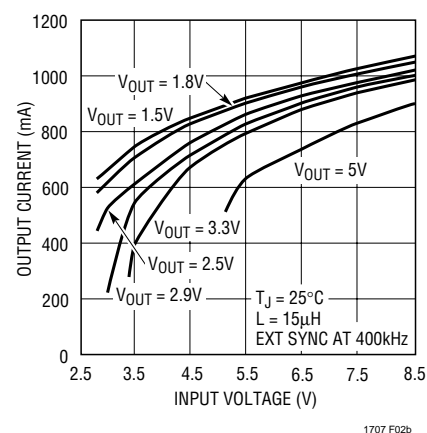

Figure 2b. Maximum Output Current vs Input Voltage (Synchronized)

Slope Compensation and Inductor Peak Current

Slope compensation provides stability by preventing sub-harmonic oscillations. It works by internally adding a ramp to the inductor current signal at duty cycles in excess of 40%. As a result, the maximum inductor peak current is lower for $V_{OUT}/V_{IN} > 0.4$ than when $V_{OUT}/V_{IN} < 0.4$. See the inductor peak current as a function of duty cycle graph in Figure 3. The worst-case peak current reduction occurs

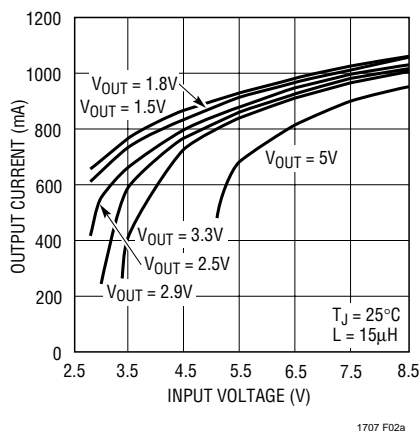

Figure 2a. Maximum Output Current vs Input Voltage (Unsynchronized)

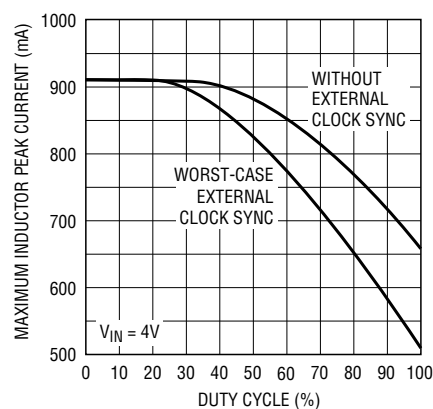

Figure 3. Maximum Inductor Peak Current vs Duty Cycle

APPLICATIONS INFORMATION

with the oscillator synchronized at its minimum frequency, i.e., to a clock just above the oscillator free-running frequency. The actual reduction in average current is less than for peak current.

The basic LTC1707 application circuit is shown in Figure 1a. External component selection is driven by the load requirement and begins with the selection of L followed by C_{IN} and C_{OUT} .

Inductor Value Calculation

The inductor selection will depend on the operating frequency of the LTC1707. The internal preset frequency is 350kHz, but can be externally synchronized up to 550kHz.

The operating frequency and inductor selection are inter-related in that higher operating frequencies allow the use of smaller inductor and capacitor values. However, operating at a higher frequency generally results in lower efficiency because of increased internal gate charge losses.

The inductor value has a direct effect on ripple current. The ripple current ΔI_L decreases with higher inductance or frequency and increases with higher V_{IN} or V_{OUT} .

$$\Delta I_L = \frac{1}{(f)(L)} V_{OUT} \left(1 - \frac{V_{OUT}}{V_{IN}} \right) \quad (1)$$

Accepting larger values of ΔI_L allows the use of low inductances, but results in higher output voltage ripple and greater core losses. A reasonable starting point for setting ripple current is $\Delta I_L = 0.4(I_{MAX})$.

The inductor value also has an effect on Burst Mode operation. The transition to low current operation begins when the inductor current peaks fall to approximately 200mA. Lower inductor values (higher ΔI_L) will cause this to occur at lower load currents, which can cause a dip in efficiency in the upper range of low current operation. In Burst Mode operation, lower inductance values will cause the burst frequency to increase.

Inductor Core Selection

Once the value for L is known, the type of inductor must be selected. High efficiency converters generally cannot afford the core loss found in low cost powdered iron cores,

forcing the use of more expensive ferrite, molypermalloy, or Kool M μ [®] cores. Actual core loss is independent of core size for a fixed inductor value, but it is very dependent on inductance selected. As inductance increases, core losses go down. Unfortunately, increased inductance requires more turns of wire and therefore copper losses will increase.

Ferrite designs have very low core losses and are preferred at high switching frequencies, so design goals can concentrate on copper loss and preventing saturation. Ferrite core material saturates “hard,” which means that inductance collapses abruptly when the peak design current is exceeded. This results in an abrupt increase in inductor ripple current and consequent output voltage ripple. Do not allow the core to saturate!

Kool M μ (from Magnetics, Inc.) is a very good, low loss core material for toroids with a “soft” saturation characteristic. Molypermalloy is slightly more efficient at high (>200kHz) switching frequencies but quite a bit more expensive. Toroids are very space efficient, especially when you can use several layers of wire, while inductors wound on bobbins are generally easier to surface mount. New designs for surface mount are available from Coiltronics, Coilcraft and Sumida.

C_{IN} and C_{OUT} Selection

In continuous mode, the source current of the top MOSFET is a square wave of duty cycle V_{OUT}/V_{IN} . To prevent large voltage transients, a low ESR input capacitor sized for the maximum RMS current must be used. The maximum RMS capacitor current is given by:

$$C_{IN} \text{ required } I_{RMS} \cong I_{MAX} \frac{[V_{OUT}(V_{IN} - V_{OUT})]^{1/2}}{V_{IN}}$$

This formula has a maximum at $V_{IN} = 2V_{OUT}$, where $I_{RMS} = I_{OUT}/2$. This simple worst-case condition is commonly used for design because even significant deviations do not offer much relief. Note that capacitor manufacturer’s ripple current ratings are often based on 2000 hours of life. This makes it advisable to further derate the capacitor, or choose a capacitor rated at a higher temperature than required. Several capacitors may also be paralleled to meet

Kool M μ is a registered trademark of Magnetics, Inc.

APPLICATIONS INFORMATION

size or height requirements in the design. Always consult the manufacturer if there is any question.

The selection of C_{OUT} is driven by the required effective series resistance (ESR). Typically, once the ESR requirement is satisfied, the capacitance is adequate for filtering. The output ripple ΔV_{OUT} is determined by:

$$\Delta V_{OUT} \cong \Delta I_L \left(ESR + \frac{1}{8fC_{OUT}} \right)$$

where f = operating frequency, C_{OUT} = output capacitance and ΔI_L = ripple current in the inductor. The output ripple is highest at maximum input voltage since ΔI_L increases with input voltage. For the LTC1707, the general rule for proper operation is:

$$C_{OUT} \text{ required ESR} < 0.25\Omega$$

Manufacturers such as Nichicon, United Chemicon and Sanyo should be considered for high performance through-hole capacitors. The OS-CON semiconductor dielectric capacitor available from Sanyo has the lowest ESR/size ratio of any aluminum electrolytic at a somewhat higher price. Once the ESR requirement for C_{OUT} has been met, the RMS current rating generally far exceeds the $I_{RIPPLE(P-P)}$ requirement. Remember ESR is typically a direct function of the volume of the capacitor.

In surface mount applications multiple capacitors may have to be paralleled to meet the ESR or RMS current handling requirements of the application. Aluminum electrolytic and dry tantalum capacitors are both available in surface mount configurations. In the case of tantalum, it is critical that the capacitors are surge tested for use in switching power supplies. An excellent choice is the AVX TPS series of surface mount tantalum, available in case heights ranging from 2mm to 4mm. Other capacitor types include Sanyo POSCAP, KEMET T510

and T495 series, Nichicon PL series and Sprague 593D and 595D series. Consult the manufacturer for other specific recommendations.

Output Voltage Programming

The output voltage is set by a resistive divider according to the following formula:

$$V_{OUT} = 0.8V \left(1 + \frac{R2}{R1} \right) \quad (2)$$

The external resistive divider is connected to the output, allowing remote voltage sensing as shown in Figure 4.

Run/Soft-Start Function

The RUN/SS pin is a dual purpose pin that provides the soft-start function and a means to shut down the LTC1707. Soft-start reduces surge currents from V_{IN} by gradually increasing the internal current limit. Power supply sequencing can also be accomplished using this pin.

An internal $2.25\mu A$ current source charges up an external capacitor C_{SS} . When the voltage on RUN/SS reaches 0.7V the LTC1707 begins operating. As the voltage on RUN/SS continues to ramp from 0.7V to 1.8V, the internal current limit is also ramped at a proportional linear rate. The current limit begins at 25mA (at $V_{RUN/SS} \leq 0.7V$) and ends at the Figure 3 value ($V_{RUN/SS} \approx 1.8V$). The output current thus ramps up slowly, charging the output capacitor. If RUN/SS has been pulled all the way to ground, there will be a delay before the current starts increasing and is given by:

$$t_{DELAY} = \frac{0.7C_{SS}}{2.25\mu A}$$

Pulling the RUN/SS pin below 0.4V puts the LTC1707 into a low quiescent current shutdown ($I_Q < 15\mu A$). This pin can be driven directly from logic as shown in Figure 5. Diode

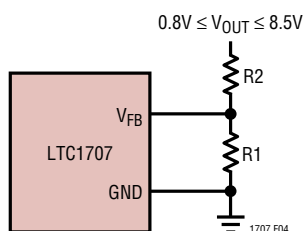

Figure 4. Setting the LTC1707 Output Voltage

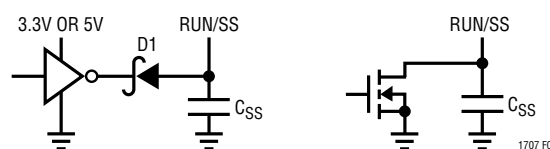

Figure 5. RUN/SS Pin Interfacing

APPLICATIONS INFORMATION

D1 in Figure 5 reduces the start delay but allows C_{SS} to ramp up slowly providing the soft-start function. This diode can be deleted if soft-start is not needed.

Efficiency Considerations

The efficiency of a switching regulator is equal to the output power divided by the input power times 100%. It is often useful to analyze individual losses to determine what is limiting the efficiency and which change would produce the most improvement. Efficiency can be expressed as:

$$\text{Efficiency} = 100\% - (L1 + L2 + L3 + \dots)$$

where L1, L2, etc. are the individual losses as a percentage of input power.

Although all dissipative elements in the circuit produce losses, two main sources usually account for most of the losses in LTC1707 circuits: V_{IN} quiescent current and I^2R losses. The V_{IN} quiescent current loss dominates the efficiency loss at very low load currents whereas the I^2R loss dominates the efficiency loss at medium to high load currents. In a typical efficiency plot, the efficiency curve at very low load currents can be misleading since the actual power lost is of no consequence as illustrated in Figure 6.

1. The V_{IN} quiescent current is due to two components: the DC bias current as given in the electrical characteristics and the internal main switch and synchronous switch gate charge currents. The gate charge current results from switching the gate capacitance of the internal power MOSFET switches. Each time the gate is switched from high to low or from low to high, a packet of charge dQ moves from V_{IN} to ground. The resulting dQ/dt is the current out of V_{IN} that is typically larger than the DC bias current. In continuous mode, $I_{GATECHG} = f(Q_T + Q_B)$ where Q_T and Q_B are the gate charges of the internal top and bottom switches. Both the DC bias and gate charge losses are proportional to V_{IN} and thus their effects will be more pronounced at higher supply voltages.
2. I^2R losses are calculated from the resistances of the internal switches R_{SW} and external inductor R_L . In continuous mode the average output current flowing through inductor L is "chopped" between the main switch and the synchronous switch. Thus, the series resistance looking into SW pin from L is a function of

both top and bottom MOSFET $R_{DS(ON)}$ and the duty cycle (DC) as follows:

$$R_{SW} = (R_{DS(ON)TOP})(DC) + (R_{DS(ON)BOT})(1 - DC)$$

The $R_{DS(ON)}$ for both the top and bottom MOSFETs can be obtained from the Typical Performance Characteristics curves. Thus, to obtain I^2R losses, simply add R_{SW} to R_L and multiply by the square of the average output current.

Other losses including C_{IN} and C_{OUT} ESR dissipative losses, MOSFET switching losses and inductor core and copper losses generally account for less than 2% total additional loss.

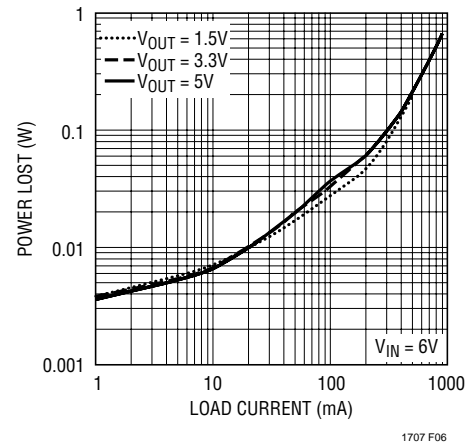

Figure 6. Power Lost vs Load Current

Checking Transient Response

The regulator loop response can be checked by looking at the load transient response. Switching regulators take several cycles to respond to a step in load current. When a load step occurs, V_{OUT} immediately shifts by an amount equal to $(\Delta I_{LOAD} \cdot ESR)$, where ESR is the effective series resistance of C_{OUT} . ΔI_{LOAD} also begins to charge or discharge C_{OUT} , which generates a feedback error signal. The regulator loop then acts to return V_{OUT} to its steady-state value. During this recovery time, V_{OUT} can be monitored for overshoot or ringing that would indicate a stability problem. The internal compensation provides adequate compensation for most applications. But if additional compensation is required, the I_{TH} pin can be used for external compensation as shown in Figure 7 (the 47pF capacitor, C_{C2} , is typically needed for noise decoupling).

APPLICATIONS INFORMATION

A second, more severe transient is caused by switching in loads with large ($>1\mu\text{F}$) supply bypass capacitors. The discharged bypass capacitors are effectively put in parallel with C_{OUT} , causing a rapid drop in V_{OUT} . No regulator can deliver enough current to prevent this problem if the load switch resistance is low and it is driven quickly. The only solution is to limit the rise time of the switch drive so that the load rise time is limited to approximately $(25 \cdot C_{\text{LOAD}})$. Thus, a $10\mu\text{F}$ capacitor charging to 3.3V would require a $250\mu\text{s}$ rise time, limiting the charging current to about 130mA .

PC Board Layout Checklist

When laying out the printed circuit board, the following checklist should be used to ensure proper operation of the LTC1707. These items are also illustrated graphically in the layout diagram of Figure 7. Check the following in your layout:

1. Are the signal and power grounds segregated? The LTC1707 signal ground consists of the resistive divider, the optional compensation network (R_{C} and C_{C1}), C_{SS} , C_{REF} and C_{C2} . The power ground consists of the (-) plate of C_{IN} , the (-) plate of C_{OUT} and Pin 4 of the LTC1707. The power ground traces should be kept short, direct and wide. The signal ground and power ground should converge to a common node in a star-ground configuration.
2. Does the V_{FB} pin connect directly to the feedback resistors? The resistive divider $R1/R2$ must be connected between the (+) plate of C_{OUT} and signal ground.
3. Does the (+) plate of C_{IN} connect to V_{IN} as closely as possible? This capacitor provides the AC current to the internal power MOSFETs.
4. Keep the switching node SW away from sensitive small-signal nodes.

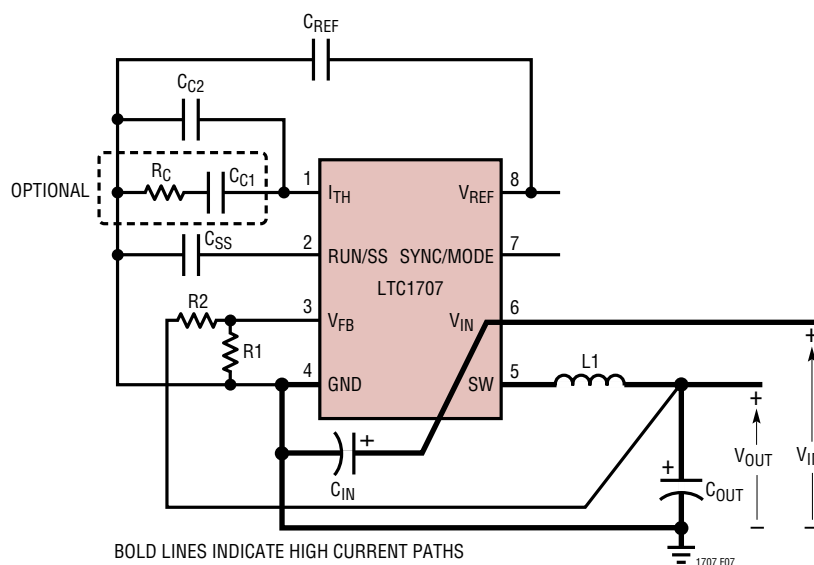

Figure 7. LTC1707 Layout Diagram

APPLICATIONS INFORMATION

Design Example

As a design example, assume the LTC1707 is used in a single lithium-ion battery-powered cellular phone application. The V_{IN} will be operating from a maximum of 4.2V down to about 2.85V. The load current requirement is a maximum of 0.3A but most of the time it will be in standby mode, requiring only 2mA. Efficiency at both low and high load currents is important. Output voltage is 2.5V. With this information we can calculate L using equation (1),

$$L = \frac{1}{(f)(\Delta I_L)} V_{OUT} \left(1 - \frac{V_{OUT}}{V_{IN}} \right) \quad (3)$$

Substituting $V_{OUT} = 2.5V$, $V_{IN} = 4.2V$, $\Delta I_L = 120mA$ and $f = 350kHz$ in equation (3) gives:

$$L = \frac{2.5V}{(350kHz)(120mA)} \left(1 - \frac{2.5V}{4.2V} \right) = 24.1\mu H$$

A 22 μH inductor works well for this application. For best efficiency choose a 1A inductor with less than 0.25 Ω series resistance.

C_{IN} will require an RMS current rating of at least 0.15A at temperature and C_{OUT} will require an ESR of less than 0.25 Ω . In most applications, the requirements for these capacitors are fairly similar.

For the feedback resistors, choose $R1 = 80.6k$. $R2$ can then be calculated from equation (2) to be:

$$R2 = \left(\frac{V_{OUT}}{0.8} - 1 \right) R1 = 171k; \text{ use } 169k$$

Figure 8 shows the complete circuit along with its efficiency curve.

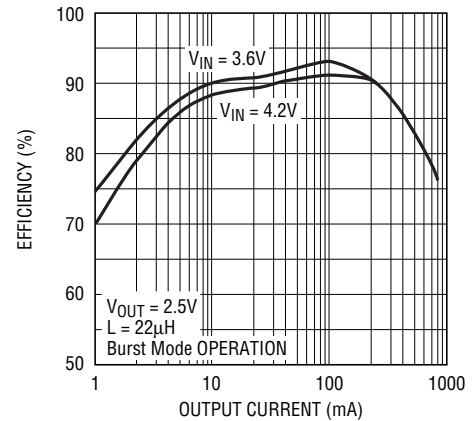
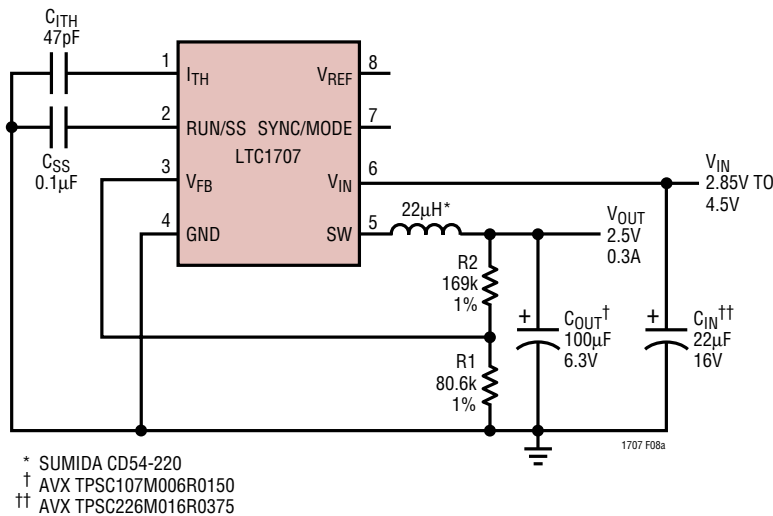
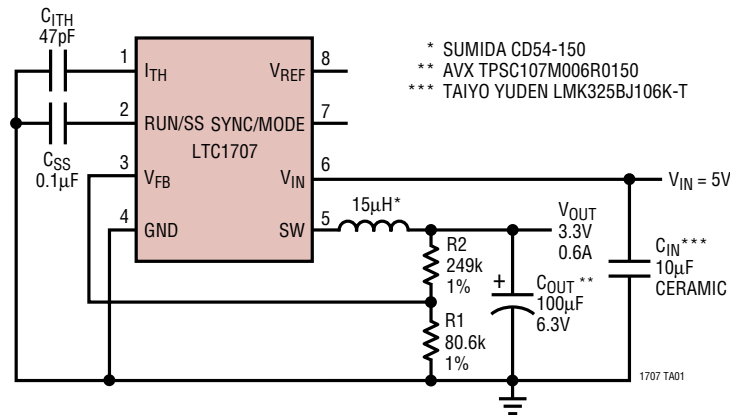

Figure 8. Single Lithium-Ion to 2.5V/0.3A Regulator from Design Example

TYPICAL APPLICATIONS

5V Input to 3.3V/0.6A Regulator



Double Lithium-Ion Battery to 5V/0.5A Low Dropout Regulator

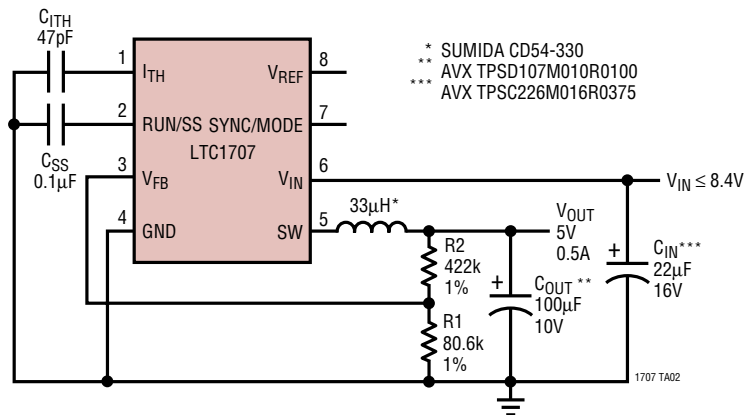

TYPICAL APPLICATIONS

3.3V Input to 2.5V/0.4A Regulator

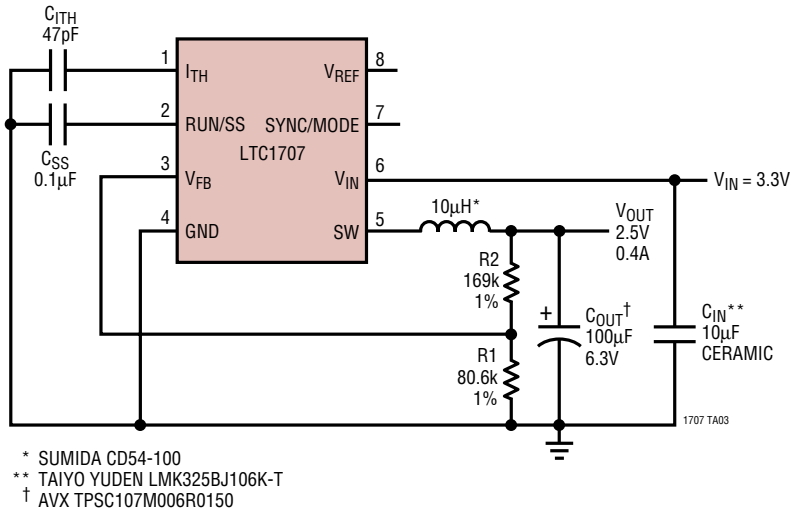

Double Lithium-Ion to 2.5V/0.5A Regulator

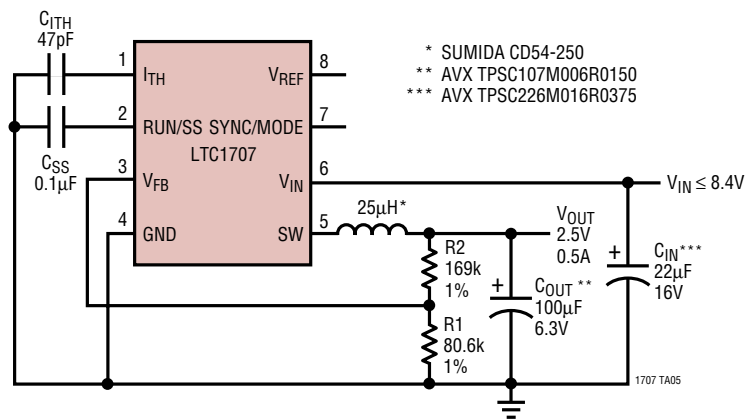

PACKAGE DESCRIPTION Dimensions in inches (millimeters) unless otherwise noted.

S8 Package
8-Lead Plastic Small Outline (Narrow 0.150)
 (LTC DWG # 05-08-1610)

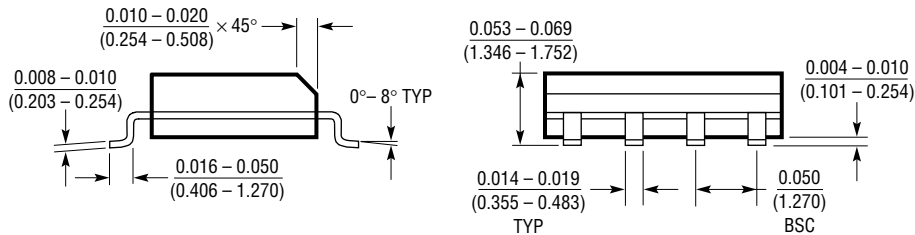
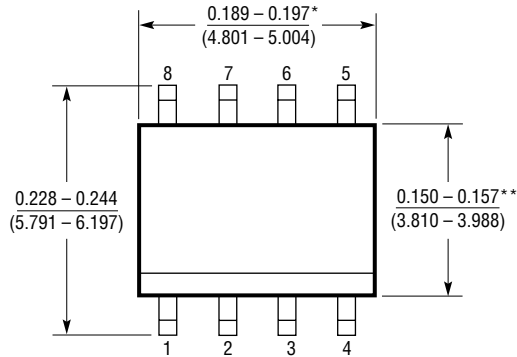

*DIMENSION DOES NOT INCLUDE MOLD FLASH. MOLD FLASH SHALL NOT EXCEED 0.006" (0.152mm) PER SIDE
 **DIMENSION DOES NOT INCLUDE INTERLEAD FLASH. INTERLEAD FLASH SHALL NOT EXCEED 0.010" (0.254mm) PER SIDE

S08 1298

TYPICAL APPLICATION

Single Lithium-Ion to 1.8V/0.3A Regulator

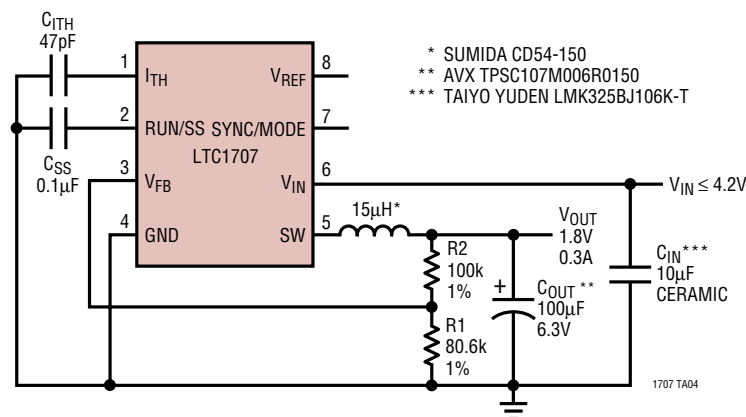

RELATED PARTS

PART NUMBER	DESCRIPTION	COMMENTS
LTC1174/LTC1174-3.3 LTC1174-5	High Efficiency Step-Down and Inverting DC/DC Converters	Monolithic Switching Regulators, I_{OUT} to 450mA, Burst Mode Operation
LTC1265	1.2A, High Efficiency Step-Down DC/DC Converter	Constant Off-Time, Monolithic, Burst Mode Operation
LT [®] 1375/LT1376	1.5A, 500kHz Step-Down Switching Regulators	High Frequency, Small Inductor, High Efficiency
LTC1436A/LTC1436A-PLL	High Efficiency, Low Noise, Synchronous Step-Down Converters	24-Pin Narrow SSOP
LTC1474/LTC1475	Low Quiescent Current Step-Down DC/DC Converters	Monolithic, I_{OUT} to 250mA, $I_Q = 10\mu A$, 8-Pin MSOP
LTC1504A	Monolithic Synchronous Step-Down Switching Regulator	Low Cost, Voltage Mode I_{OUT} to 500mA, V_{IN} from 4V to 10V
LTC1622	Low Input Voltage Current Mode Step-Down DC/DC Controller	550kHz Constant Frequency, External P-Channel Switch, I_{OUT} to 4A, V_{IN} From 2V to 10V
LTC1626	Low Voltage, High Efficiency Step-Down DC/DC Converter	Monolithic, Constant Off-Time, I_{OUT} to 600mA, Low Supply Voltage Range: 2.5V to 6V
LTC1627	Monolithic Synchronous Step-Down Switching Regulator	Constant Frequency, I_{OUT} to 500mA, Secondary Winding Regulation, V_{IN} from 2.65V to 8.5V
LTC1701	Monolithic Current Mode Step-Down Switching Regulator	Constant Off-Time, I_{OUT} to 500mA, 1MHz Operation, V_{IN} from 2.5V to 5.5V
LTC1735	High Efficiency, Synchronous Step-Down Converter	16-Pin SO and SSOP, V_{IN} Up to 36V, Fault Protection
LTC1772	Low Input Voltage Current Mode Step-Down DC/DC Controller	550kHz, 6-Pin SOT-23, I_{OUT} Up to 5A, V_{IN} from 2.2V to 10V
LTC1877	High Efficiency Monolithic Step-Down Regulator	550kHz, MS8, V_{IN} Up to 10V, $I_Q = 10\mu A$, I_{OUT} to 600mA
LTC1878	High Efficiency Monolithic Step-Down Regulator	550kHz, MS8, V_{IN} Up to 6V, $I_Q = 10\mu A$, I_{OUT} to 600mA

Looking for pricing, stock, or lifecycle information?

Click below to explore more details on WIN SOURCE:

 [View LTC1707CS8#TRPBF on WIN SOURCE](#)

 [Linear Technology](#) Information

Optimize Your Supply Chain with WIN SOURCE Solutions

-  Global Sourcing Solution
-  Obsolete Management
-  Cost Control Management
-  Shortage Management
-  Alternative Solution
-  Excess Inventory Management