



**THE DATASHEET OF  
LTC1778EGN#TR**



## FEATURES

- No Sense Resistor Required
- True Current Mode Control
- Optimized for High Step-Down Ratios
- $t_{ON(MIN)} \leq 100ns$
- Extremely Fast Transient Response
- Stable with Ceramic  $C_{OUT}$
- Dual N-Channel MOSFET Synchronous Drive
- Power Good Output Voltage Monitor (LTC1778)
- Adjustable On-Time (LTC1778-1)
- Wide  $V_{IN}$  Range: 4V to 36V
- $\pm 1\%$  0.8V Voltage Reference
- Adjustable Current Limit
- Adjustable Switching Frequency
- Programmable Soft-Start
- Output Overvoltage Protection
- Optional Short-Circuit Shutdown Timer
- Micropower Shutdown:  $I_Q < 30\mu A$
- Available in a 16-Pin Narrow SSOP Package

## APPLICATIONS

- Notebook and Palmtop Computers
- Distributed Power Systems

## DESCRIPTION

The LTC<sup>®</sup>1778 is a synchronous step-down switching regulator controller optimized for CPU power. The controller uses a valley current control architecture to deliver very low duty cycles with excellent transient response without requiring a sense resistor. Operating frequency is selected by an external resistor and is compensated for variations in  $V_{IN}$ .

Discontinuous mode operation provides high efficiency operation at light loads. A forced continuous control pin reduces noise and RF interference, and can assist secondary winding regulation by disabling discontinuous operation when the main output is lightly loaded.

Fault protection is provided by internal foldback current limiting, an output overvoltage comparator and optional short-circuit shutdown timer. Soft-start capability for supply sequencing is accomplished using an external timing capacitor. The regulator current limit level is user programmable. Wide supply range allows operation from 4V to 36V at the input and from 0.8V up to  $(0.9)V_{IN}$  at the output.

LT, LTC and LT are registered trademarks of Linear Technology Corporation. No  $R_{SENSE}$  is a trademark of Linear Technology Corporation. All other trademarks are the property of their respective owners. Protected by U.S. Patents, including 5481178, 6100678, 6580258, 5847554, 6304066

## TYPICAL APPLICATION

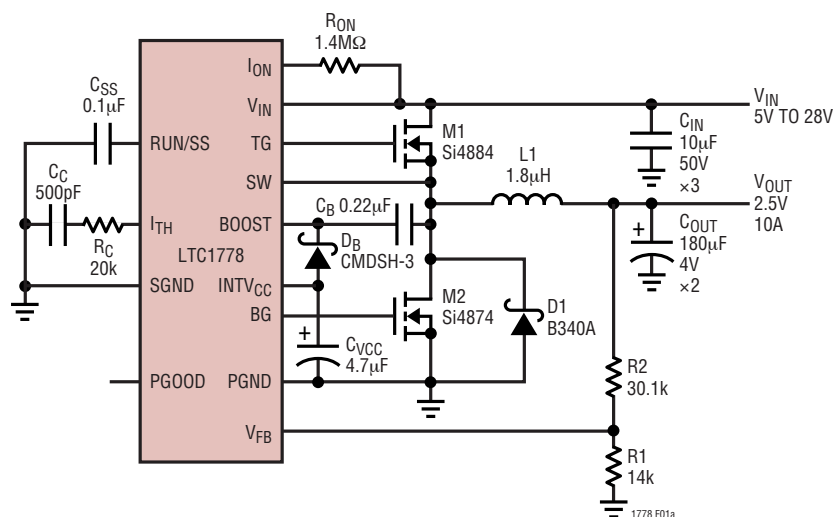
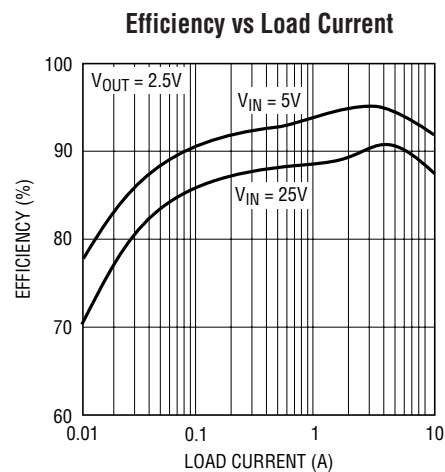

Figure 1. High Efficiency Step-Down Converter



1778 F01b

# LTC1778/LTC1778-1

## ABSOLUTE MAXIMUM RATINGS (Note 1)

Input Supply Voltage ( $V_{IN}$ , $I_{ON}$ ) .....	36V to -0.3V	TG, BG, INTV <sub>CC</sub> , EXTV <sub>CC</sub> Peak Currents .....	2A
Boosted Topside Driver Supply Voltage (BOOST) .....	42V to -0.3V	TG, BG, INTV <sub>CC</sub> , EXTV <sub>CC</sub> RMS Currents .....	50mA
SW Voltage .....	36V to -5V	Operating Ambient Temperature Range (Note 4)	
EXTV <sub>CC</sub> , (BOOST - SW), RUN/SS, PGOOD Voltages .....	7V to -0.3V	LTC1778E .....	-40°C to 85°C
FCB, V <sub>ON</sub> , V <sub>RNG</sub> Voltages .....	INTV <sub>CC</sub> + 0.3V to -0.3V	LTC1778I .....	-40°C to 125°C
I <sub>TH</sub> , V <sub>FB</sub> Voltages .....	2.7V to -0.3V	Junction Temperature (Note 2) .....	125°C
		Storage Temperature Range .....	-65°C to 150°C
		Lead Temperature (Soldering, 10 sec) .....	300°C

## PACKAGE/ORDER INFORMATION

<p>TOP VIEW</p> <p>GN PACKAGE 16-LEAD PLASTIC SSOP T<sub>JMAX</sub> = 125°C, θ<sub>JA</sub> = 130°C/W</p>	<p>ORDER PART NUMBER</p> <p>LTC1778EGN LTC1778IGN</p> <p>GN PART MARKING</p> <p>1778 1778I</p>	<p>TOP VIEW</p> <p>GN PACKAGE 16-LEAD PLASTIC SSOP T<sub>JMAX</sub> = 125°C, θ<sub>JA</sub> = 130°C/W</p>	<p>ORDER PART NUMBER</p> <p>LTC1778EGN-1</p> <p>GN PART MARKING</p> <p>17781</p>
---	--	---	--

Consult LTC Marketing for parts specified with wider operating temperature ranges.

## ELECTRICAL CHARACTERISTICS

The ● denotes specifications which apply over the full operating temperature range, otherwise specifications are T<sub>A</sub> = 25°C. V<sub>IN</sub> = 15V unless otherwise noted.

SYMBOL	PARAMETER	CONDITIONS	MIN	TYP	MAX	UNITS	
<b>Main Control Loop</b>							
I <sub>Q</sub>	Input DC Supply Current			900	2000	μA	
	Normal						
	Shutdown Supply Current			15	30	μA	
V <sub>FB</sub>	Feedback Reference Voltage	I <sub>TH</sub> = 1.2V (Note 3) LTC1778E	● 0.792	0.800	0.808	V	
		I <sub>TH</sub> = 1.2V (Note 3) LTC1778I	● 0.792	0.800	0.812	V	
ΔV <sub>FB(LINEREG)</sub>	Feedback Voltage Line Regulation	V <sub>IN</sub> = 4V to 30V, I <sub>TH</sub> = 1.2V (Note 3)		0.002		%/V	
ΔV <sub>FB(LOADREG)</sub>	Feedback Voltage Load Regulation	I <sub>TH</sub> = 0.5V to 1.9V (Note 3)	●	-0.05	-0.3	%	
I <sub>FB</sub>	Feedback Input Current	V <sub>FB</sub> = 0.8V		-5	±50	nA	
g <sub>m(EA)</sub>	Error Amplifier Transconductance	I <sub>TH</sub> = 1.2V (Note 3)	● 1.4	1.7	2	mS	
V <sub>FCB</sub>	Forced Continuous Threshold		● 0.76	0.8	0.84	V	
I <sub>FCB</sub>	Forced Continuous Pin Current	V <sub>FCB</sub> = 0.8V		-1	-2	μA	
t <sub>ON</sub>	On-Time	I <sub>ON</sub> = 30μA, V <sub>ON</sub> = 0V (LTC1778-1)		198	233	268	ns
		I <sub>ON</sub> = 15μA, V <sub>ON</sub> = 0V (LTC1778-1)		396	466	536	ns
t <sub>ON(MIN)</sub>	Minimum On-Time	I <sub>ON</sub> = 180μA		50	100	ns	

1778fb

## ELECTRICAL CHARACTERISTICS

The ● denotes specifications which apply over the full operating temperature range, otherwise specifications are  $T_A = 25^\circ\text{C}$ .  $V_{IN} = 15\text{V}$  unless otherwise noted.

SYMBOL	PARAMETER	CONDITIONS	MIN	TYP	MAX	UNITS	
$t_{\text{OFF(MIN)}}$	Minimum Off-Time	$I_{\text{ON}} = 30\mu\text{A}$		250	400	ns	
$V_{\text{SENSE(MAX)}}$	Maximum Current Sense Threshold $V_{\text{PGND}} - V_{\text{SW}}$	$V_{\text{RNG}} = 1\text{V}, V_{\text{FB}} = 0.76\text{V}$	●	113	133	153	mV
		$V_{\text{RNG}} = 0\text{V}, V_{\text{FB}} = 0.76\text{V}$	●	79	93	107	mV
		$V_{\text{RNG}} = \text{INTV}_{\text{CC}}, V_{\text{FB}} = 0.76\text{V}$	●	158	186	214	mV
$V_{\text{SENSE(MIN)}}$	Minimum Current Sense Threshold $V_{\text{PGND}} - V_{\text{SW}}$	$V_{\text{RNG}} = 1\text{V}, V_{\text{FB}} = 0.84\text{V}$			-67	mV	
		$V_{\text{RNG}} = 0\text{V}, V_{\text{FB}} = 0.84\text{V}$			-47	mV	
		$V_{\text{RNG}} = \text{INTV}_{\text{CC}}, V_{\text{FB}} = 0.84\text{V}$			-93	mV	
$\Delta V_{\text{FB(OV)}}$	Output Overvoltage Fault Threshold		5.5	7.5	9.5	%	
$V_{\text{FB(UV)}}$	Output Undervoltage Fault Threshold		520	600	680	mV	
$V_{\text{RUN/SS(ON)}}$	RUN Pin Start Threshold		●	0.8	1.5	2	V
$V_{\text{RUN/SS(LE)}}$	RUN Pin Latchoff Enable Threshold	RUN/SS Pin Rising			4	4.5	V
$V_{\text{RUN/SS(LT)}}$	RUN Pin Latchoff Threshold	RUN/SS Pin Falling			3.5	4.2	V
$I_{\text{RUN/SS(C)}}$	Soft-Start Charge Current	$V_{\text{RUN/SS}} = 0\text{V}$		-0.5	-1.2	-3	$\mu\text{A}$
$I_{\text{RUN/SS(D)}}$	Soft-Start Discharge Current	$V_{\text{RUN/SS}} = 4.5\text{V}, V_{\text{FB}} = 0\text{V}$		0.8	1.8	3	$\mu\text{A}$
$V_{\text{IN(UVLO)}}$	Undervoltage Lockout	$V_{\text{IN}}$ Falling	●		3.4	3.9	V
$V_{\text{IN(UVLOR)}}$	Undervoltage Lockout Release	$V_{\text{IN}}$ Rising	●		3.5	4	V
TG $R_{\text{UP}}$	TG Driver Pull-Up On Resistance	TG High			2	3	$\Omega$
TG $R_{\text{DOWN}}$	TG Driver Pull-Down On Resistance	TG Low			2	3	$\Omega$
BG $R_{\text{UP}}$	BG Driver Pull-Up On Resistance	BG High			3	4	$\Omega$
BG $R_{\text{DOWN}}$	BG Driver Pull-Down On Resistance	BG Low			1	2	$\Omega$
TG $t_r$	TG Rise Time	$C_{\text{LOAD}} = 3300\text{pF}$			20		ns
TG $t_f$	TG Fall Time	$C_{\text{LOAD}} = 3300\text{pF}$			20		ns
BG $t_r$	BG Rise Time	$C_{\text{LOAD}} = 3300\text{pF}$			20		ns
BG $t_f$	BG Fall Time	$C_{\text{LOAD}} = 3300\text{pF}$			20		ns

### Internal $V_{\text{CC}}$ Regulator

$V_{\text{INTVCC}}$	Internal $V_{\text{CC}}$ Voltage	$6\text{V} < V_{\text{IN}} < 30\text{V}, V_{\text{EXTVCC}} = 4\text{V}$	●	4.7	5	5.3	V
$\Delta V_{\text{LDO(LOADREG)}}$	Internal $V_{\text{CC}}$ Load Regulation	$I_{\text{CC}} = 0\text{mA}$ to $20\text{mA}, V_{\text{EXTVCC}} = 4\text{V}$			-0.1	$\pm 2$	%
$V_{\text{EXTVCC}}$	EXTV <sub>CC</sub> Switchover Voltage	$I_{\text{CC}} = 20\text{mA}, V_{\text{EXTVCC}}$ Rising	●	4.5	4.7		V
$\Delta V_{\text{EXTVCC}}$	EXTV <sub>CC</sub> Switch Drop Voltage	$I_{\text{CC}} = 20\text{mA}, V_{\text{EXTVCC}} = 5\text{V}$			150	300	mV
$\Delta V_{\text{EXTVCC(HYS)}}$	EXTV <sub>CC</sub> Switchover Hysteresis				200		mV

### PGOOD Output (LTC1778 Only)

$\Delta V_{\text{FBH}}$	PGOOD Upper Threshold	$V_{\text{FB}}$ Rising		5.5	7.5	9.5	%
$\Delta V_{\text{FBL}}$	PGOOD Lower Threshold	$V_{\text{FB}}$ Falling		-5.5	-7.5	-9.5	%
$\Delta V_{\text{FB(HYS)}}$	PGOOD Hysteresis	$V_{\text{FB}}$ Returning			1	2	%
$V_{\text{PGL}}$	PGOOD Low Voltage	$I_{\text{PGOOD}} = 5\text{mA}$			0.15	0.4	V

**Note 1:** Absolute Maximum Ratings are those values beyond which the life of a device may be impaired.

**Note 2:**  $T_J$  is calculated from the ambient temperature  $T_A$  and power dissipation  $P_D$  as follows:

$$\text{LTC1778E: } T_J = T_A + (P_D \cdot 130^\circ\text{C/W})$$

**Note 3:** The LTC1778 is tested in a feedback loop that adjusts  $V_{\text{FB}}$  to achieve a specified error amplifier output voltage ( $I_{\text{TH}}$ ).

**Note 4:** The LTC1778E is guaranteed to meet performance specifications from  $0^\circ\text{C}$  to  $70^\circ\text{C}$ . Specifications over the  $-40^\circ\text{C}$  to  $85^\circ\text{C}$  operating temperature range are assured by design, characterization and correlation with statistical process controls. The LTC1778I is guaranteed over the full  $-40^\circ\text{C}$  to  $125^\circ\text{C}$  operating temperature range.

# TYPICAL PERFORMANCE CHARACTERISTICS

**Transient Response**

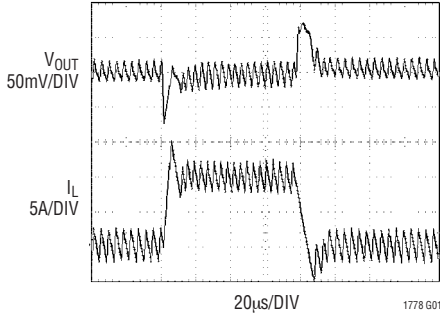

LOAD STEP 0A TO 10A  
 $V_{IN} = 15V$   
 $V_{OUT} = 2.5V$   
 $FCB = 0V$   
 FIGURE 9 CIRCUIT

**Transient Response (Discontinuous Mode)**

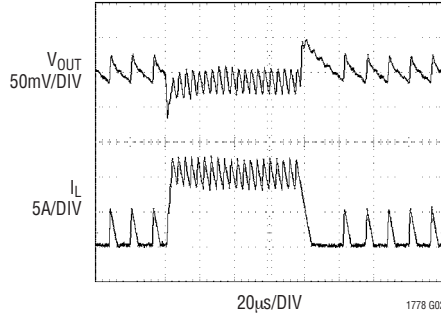

LOAD STEP 1A TO 10A  
 $V_{IN} = 15V$   
 $V_{OUT} = 2.5V$   
 $FCB = INTV_{CC}$   
 FIGURE 9 CIRCUIT

**Start-Up**

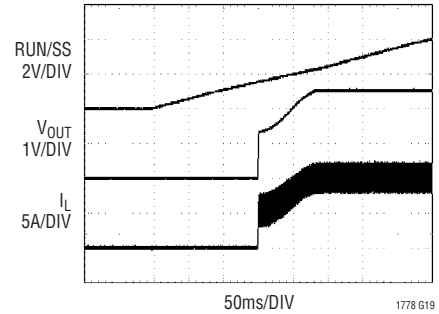

$V_{IN} = 15V$   
 $V_{OUT} = 2.5V$   
 $R_{LOAD} = 0.25\Omega$

**Efficiency vs Load Current**

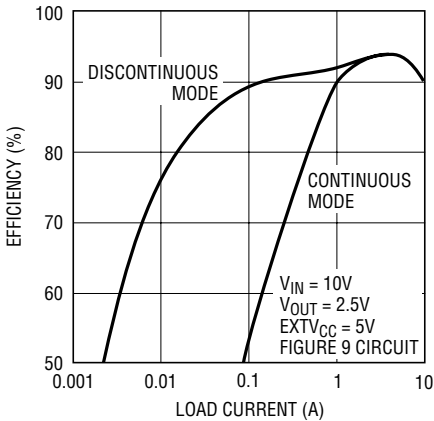

1778 G03

**Efficiency vs Input Voltage**

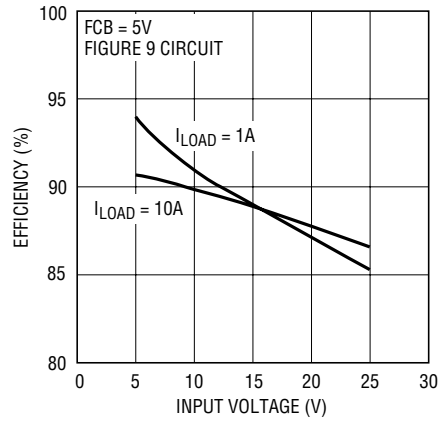

1778 G04

**Frequency vs Input Voltage**

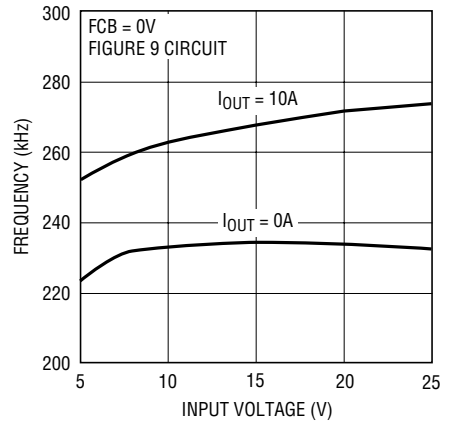

1778 G05

**Frequency vs Load Current**

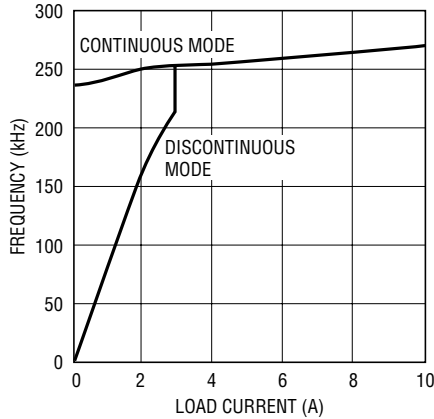

1778 G26

**Load Regulation**

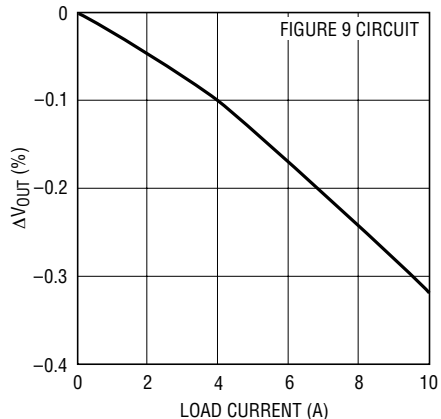

1778 G06

**I<sub>TH</sub> Voltage vs Load Current**

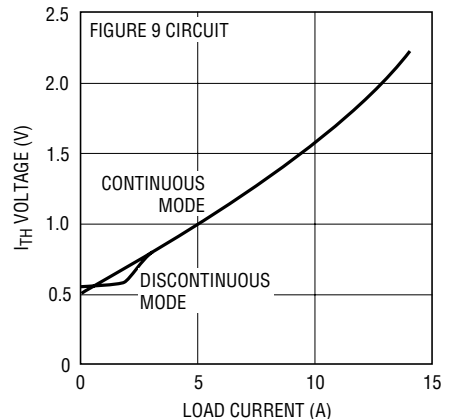

1778 G07

# TYPICAL PERFORMANCE CHARACTERISTICS

**Current Sense Threshold vs  $I_{TH}$  Voltage**

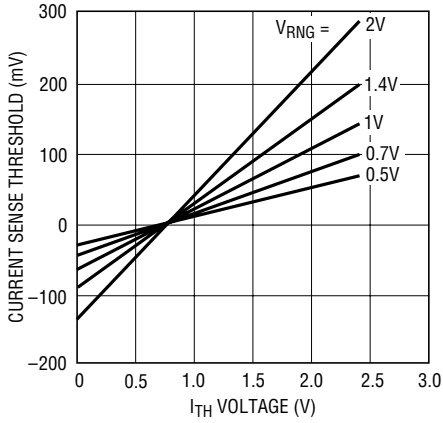

1778 G08

**On-Time vs  $I_{ON}$  Current**

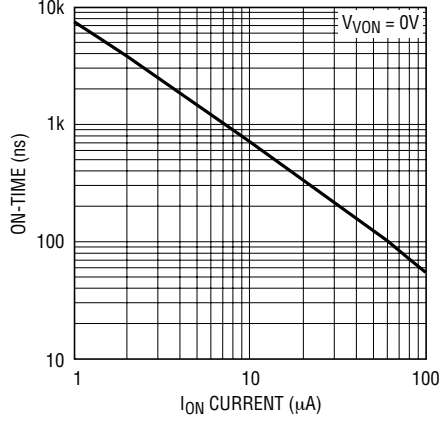

1778 G20

**On-Time vs  $V_{ON}$  Voltage**

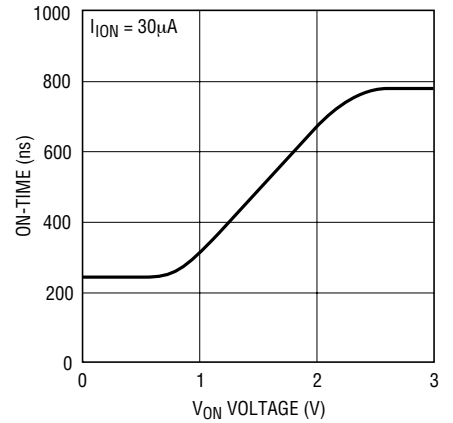

1778 G21

**On-Time vs Temperature**

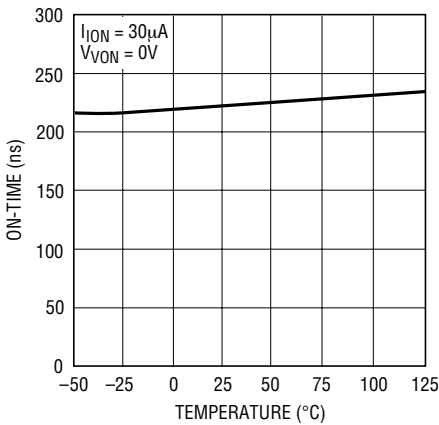

1778 G22

**Current Limit Foldback**

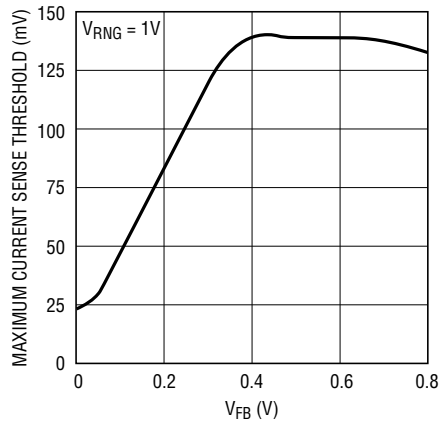

1778 G09

**Maximum Current Sense Threshold vs  $V_{RNG}$  Voltage**

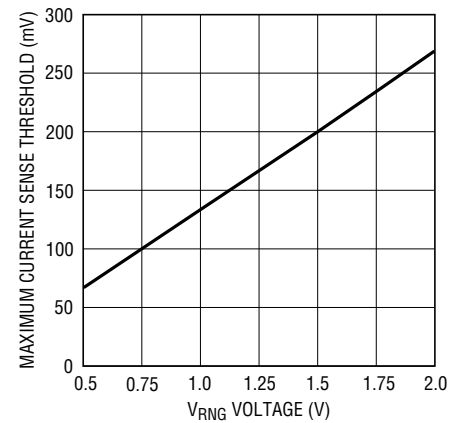

1778 G10

**Maximum Current Sense Threshold vs RUN/SS Voltage**

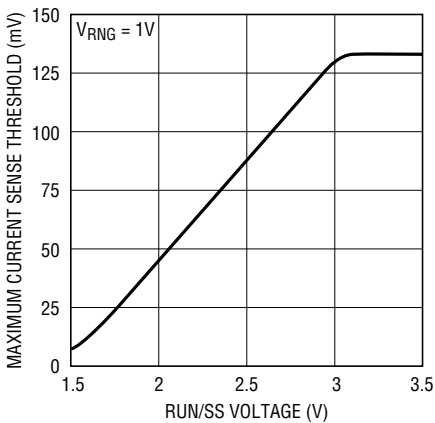

1778 G23

**Maximum Current Sense Threshold vs Temperature**

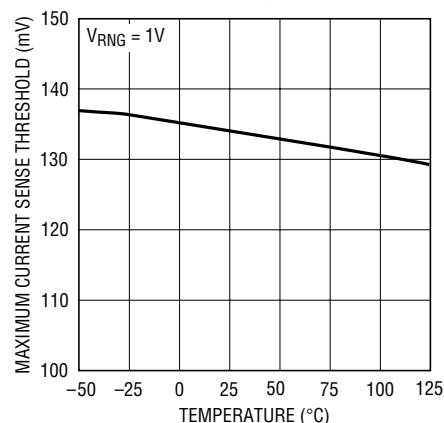

1778 G11

**Feedback Reference Voltage vs Temperature**

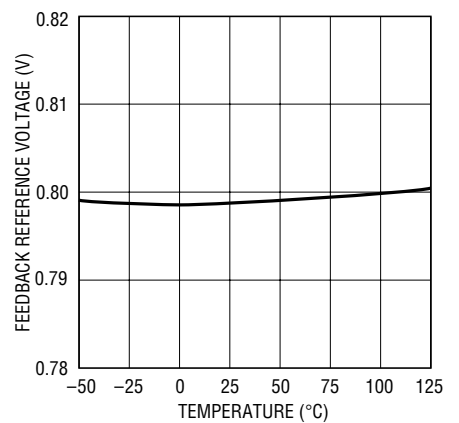

1778 G12

**TYPICAL PERFORMANCE CHARACTERISTICS**

**Error Amplifier  $g_m$  vs Temperature**

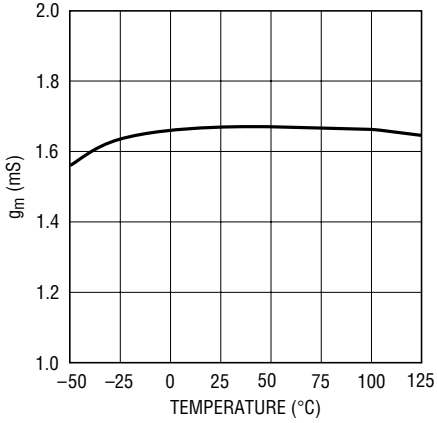

1778 G13

**Input and Shutdown Currents vs Input Voltage**

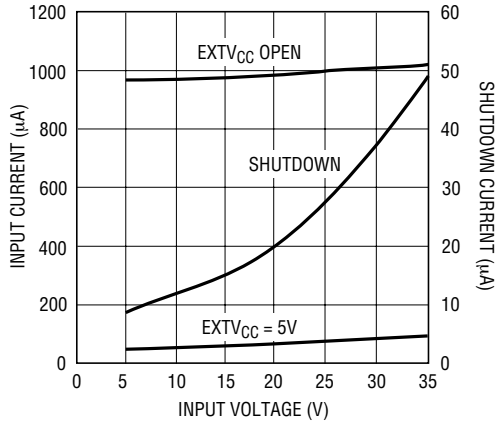

1778 G24

**INTV<sub>CC</sub> Load Regulation**

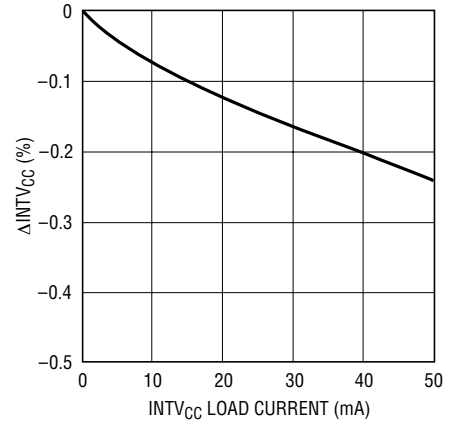

1778 G25

**EXTV<sub>CC</sub> Switch Resistance vs Temperature**

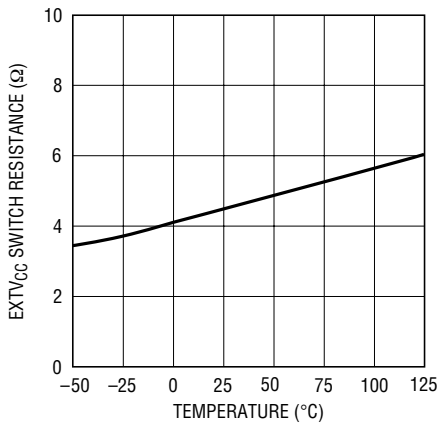

1778 G14

**FCB Pin Current vs Temperature**

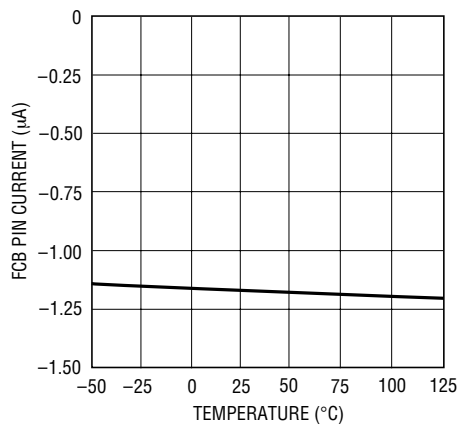

1778 G15

**RUN/SS Pin Current vs Temperature**

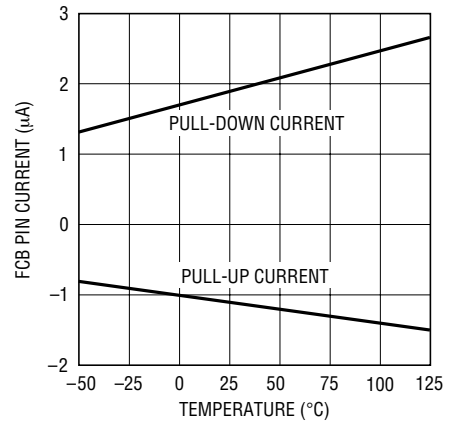

1778 G16

**RUN/SS Latchoff Thresholds vs Temperature**

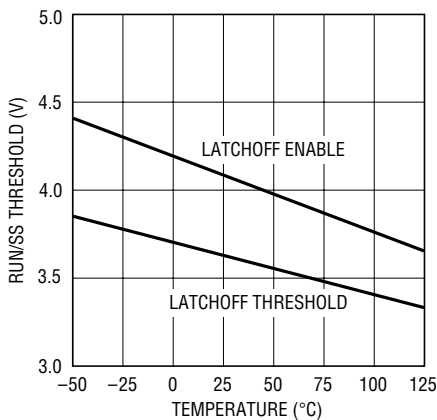

1778 G17

**Undervoltage Lockout Threshold vs Temperature**

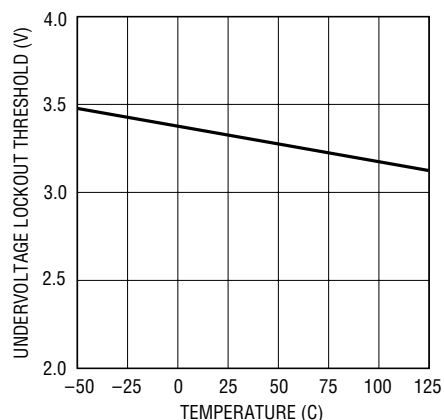

1778 G18

## PIN FUNCTIONS

**RUN/SS (Pin 1):** Run Control and Soft-Start Input. A capacitor to ground at this pin sets the ramp time to full output current (approximately  $3s/\mu F$ ) and the time delay for overcurrent latchoff (see Applications Information). Forcing this pin below 0.8V shuts down the device.

**PGOOD (Pin 2, LTC1778):** Power Good Output. Open drain logic output that is pulled to ground when the output voltage is not within  $\pm 7.5\%$  of the regulation point.

**V<sub>ON</sub> (Pin 2, LTC1778-1):** On-Time Voltage Input. Voltage trip point for the on-time comparator. Tying this pin to the output voltage or an external resistive divider from the output makes the on-time proportional to  $V_{OUT}$ . The comparator input defaults to 0.7V when the pin is grounded or unavailable (LTC1778) and defaults to 2.4V when the pin is tied to  $INTV_{CC}$ . Tie this pin to  $INTV_{CC}$  in high  $V_{OUT}$  applications to use a lower  $R_{ON}$  value.

**V<sub>RNG</sub> (Pin 3):** Sense Voltage Range Input. The voltage at this pin is ten times the nominal sense voltage at maximum output current and can be set from 0.5V to 2V by a resistive divider from  $INTV_{CC}$ . The nominal sense voltage defaults to 70mV when this pin is tied to ground, 140mV when tied to  $INTV_{CC}$ .

**FCB (Pin 4):** Forced Continuous Input. Tie this pin to ground to force continuous synchronous operation at low load, to  $INTV_{CC}$  to enable discontinuous mode operation at low load or to a resistive divider from a secondary output when using a secondary winding.

**I<sub>TH</sub> (Pin 5):** Current Control Threshold and Error Amplifier Compensation Point. The current comparator threshold increases with this control voltage. The voltage ranges from 0V to 2.4V with 0.8V corresponding to zero sense voltage (zero current).

**SGND (Pin 6):** Signal Ground. All small-signal components and compensation components should connect to this ground, which in turn connects to PGND at one point.

**I<sub>ON</sub> (Pin 7):** On-Time Current Input. Tie a resistor from  $V_{IN}$  to this pin to set the one-shot timer current and thereby set the switching frequency.

**V<sub>FB</sub> (Pin 8):** Error Amplifier Feedback Input. This pin connects the error amplifier input to an external resistive divider from  $V_{OUT}$ .

**EXTV<sub>CC</sub> (Pin 9):** External  $V_{CC}$  Input. When  $EXTV_{CC}$  exceeds 4.7V, an internal switch connects this pin to  $INTV_{CC}$  and shuts down the internal regulator so that controller and gate drive power is drawn from  $EXTV_{CC}$ . Do not exceed 7V at this pin and ensure that  $EXTV_{CC} < V_{IN}$ .

**V<sub>IN</sub> (Pin 10):** Main Input Supply. Decouple this pin to PGND with an RC filter ( $1\Omega$ ,  $0.1\mu F$ ).

**INTV<sub>CC</sub> (Pin 11):** Internal 5V Regulator Output. The driver and control circuits are powered from this voltage. Decouple this pin to power ground with a minimum of  $4.7\mu F$  low ESR tantalum capacitor.

**BG (Pin 12):** Bottom Gate Drive. Drives the gate of the bottom N-channel MOSFET between ground and  $INTV_{CC}$ .

**PGND (Pin 13):** Power Ground. Connect this pin closely to the source of the bottom N-channel MOSFET, the (–) terminal of  $C_{VCC}$  and the (–) terminal of  $C_{IN}$ .

**SW (Pin 14):** Switch Node. The (–) terminal of the bootstrap capacitor  $C_B$  connects here. This pin swings from a diode voltage drop below ground up to  $V_{IN}$ .

**TG (Pin 15):** Top Gate Drive. Drives the top N-channel MOSFET with a voltage swing equal to  $INTV_{CC}$  superimposed on the switch node voltage SW.

**BOOST (Pin 16):** Boosted Floating Driver Supply. The (+) terminal of the bootstrap capacitor  $C_B$  connects here. This pin swings from a diode voltage drop below  $INTV_{CC}$  up to  $V_{IN} + INTV_{CC}$ .



## OPERATION

### Main Control Loop

The LTC1778 is a current mode controller for DC/DC step-down converters. In normal operation, the top MOSFET is turned on for a fixed interval determined by a one-shot timer OST. When the top MOSFET is turned off, the bottom MOSFET is turned on until the current comparator  $I_{CMP}$  trips, restarting the one-shot timer and initiating the next cycle. Inductor current is determined by sensing the voltage between the PGND and SW pins using the bottom MOSFET on-resistance. The voltage on the  $I_{TH}$  pin sets the comparator threshold corresponding to inductor valley current. The error amplifier EA adjusts this voltage by comparing the feedback signal  $V_{FB}$  from the output voltage with an internal 0.8V reference. If the load current increases, it causes a drop in the feedback voltage relative to the reference. The  $I_{TH}$  voltage then rises until the average inductor current again matches the load current.

At low load currents, the inductor current can drop to zero and become negative. This is detected by current reversal comparator  $I_{REV}$  which then shuts off M2, resulting in discontinuous operation. Both switches will remain off with the output capacitor supplying the load current until the  $I_{TH}$  voltage rises above the zero current level (0.8V) to initiate another cycle. Discontinuous mode operation is disabled by comparator F when the FCB pin is brought below 0.8V, forcing continuous synchronous operation.

The operating frequency is determined implicitly by the top MOSFET on-time and the duty cycle required to maintain regulation. The one-shot timer generates an on-time that is proportional to the ideal duty cycle, thus holding frequency approximately constant with changes in  $V_{IN}$ . The nominal frequency can be adjusted with an external resistor  $R_{ON}$ .

Overvoltage and undervoltage comparators OV and UV pull the PGOOD output low if the output feedback voltage exits a  $\pm 7.5\%$  window around the regulation point.

Furthermore, in an overvoltage condition, M1 is turned off and M2 is turned on and held on until the overvoltage condition clears.

Foldback current limiting is provided if the output is shorted to ground. As  $V_{FB}$  drops, the buffered current threshold voltage  $I_{THB}$  is pulled down by clamp Q3 to a 1V level set by Q4 and Q6. This reduces the inductor valley current level to one sixth of its maximum value as  $V_{FB}$  approaches 0V.

Pulling the RUN/SS pin low forces the controller into its shutdown state, turning off both M1 and M2. Releasing the pin allows an internal 1.2 $\mu$ A current source to charge up an external soft-start capacitor  $C_{SS}$ . When this voltage reaches 1.5V, the controller turns on and begins switching, but with the  $I_{TH}$  voltage clamped at approximately 0.6V below the RUN/SS voltage. As  $C_{SS}$  continues to charge, the soft-start current limit is removed.

### INTV<sub>CC</sub>/EXTV<sub>CC</sub> Power

Power for the top and bottom MOSFET drivers and most of the internal controller circuitry is derived from the INTV<sub>CC</sub> pin. The top MOSFET driver is powered from a floating bootstrap capacitor  $C_B$ . This capacitor is recharged from INTV<sub>CC</sub> through an external Schottky diode  $D_B$  when the top MOSFET is turned off. When the EXTV<sub>CC</sub> pin is grounded, an internal 5V low dropout regulator supplies the INTV<sub>CC</sub> power from  $V_{IN}$ . If EXTV<sub>CC</sub> rises above 4.7V, the internal regulator is turned off, and an internal switch connects EXTV<sub>CC</sub> to INTV<sub>CC</sub>. This allows a high efficiency source connected to EXTV<sub>CC</sub>, such as an external 5V supply or a secondary output from the converter, to provide the INTV<sub>CC</sub> power. Voltages up to 7V can be applied to EXTV<sub>CC</sub> for additional gate drive. If the input voltage is low and INTV<sub>CC</sub> drops below 3.5V, undervoltage lockout circuitry prevents the power switches from turning on.

## APPLICATIONS INFORMATION

The basic LTC1778 application circuit is shown in Figure 1. External component selection is primarily determined by the maximum load current and begins with the selection of the sense resistance and power MOSFET switches. The LTC1778 uses the on-resistance of the synchronous power MOSFET for determining the inductor current. The desired amount of ripple current and operating frequency largely determines the inductor value. Finally,  $C_{IN}$  is selected for its ability to handle the large RMS current into the converter and  $C_{OUT}$  is chosen with low enough ESR to meet the output voltage ripple and transient specification.

### Choosing the LTC1778 or LTC1778-1

The LTC1778 has an open-drain PGOOD output that indicates when the output voltage is within  $\pm 7.5\%$  of the regulation point. The LTC1778-1 trades the PGOOD pin for a  $V_{ON}$  pin that allows the on-time to be adjusted. Tying the  $V_{ON}$  pin high results in lower values for  $R_{ON}$  which is useful in high  $V_{OUT}$  applications. The  $V_{ON}$  pin also provides a means to adjust the on-time to maintain constant frequency operation in applications where  $V_{OUT}$  changes and to correct minor frequency shifts with changes in load current. Finally, the  $V_{ON}$  pin can be used to provide additional current limiting in positive-to-negative converters and as a control input to synchronize the switching frequency with a phase locked loop.

### Maximum Sense Voltage and $V_{RNG}$ Pin

Inductor current is determined by measuring the voltage across a sense resistance that appears between the PGND and SW pins. The maximum sense voltage is set by the voltage applied to the  $V_{RNG}$  pin and is equal to approximately  $(0.133)V_{RNG}$ . The current mode control loop will not allow the inductor current valleys to exceed  $(0.133)V_{RNG}/R_{SENSE}$ . In practice, one should allow some margin for variations in the LTC1778 and external component values and a good guide for selecting the sense resistance is:

$$R_{SENSE} = \frac{V_{RNG}}{10 \cdot I_{OUT(MAX)}}$$

An external resistive divider from  $INTV_{CC}$  can be used to set the voltage of the  $V_{RNG}$  pin between 0.5V and 2V

resulting in nominal sense voltages of 50mV to 200mV. Additionally, the  $V_{RNG}$  pin can be tied to SGND or  $INTV_{CC}$  in which case the nominal sense voltage defaults to 70mV or 140mV, respectively. The maximum allowed sense voltage is about 1.33 times this nominal value.

### Power MOSFET Selection

The LTC1778 requires two external N-channel power MOSFETs, one for the top (main) switch and one for the bottom (synchronous) switch. Important parameters for the power MOSFETs are the breakdown voltage  $V_{(BR)DSS}$ , threshold voltage  $V_{(GS)TH}$ , on-resistance  $R_{DS(ON)}$ , reverse transfer capacitance  $C_{RSS}$  and maximum current  $I_{DS(MAX)}$ .

The gate drive voltage is set by the 5V  $INTV_{CC}$  supply. Consequently, logic-level threshold MOSFETs must be used in LTC1778 applications. If the input voltage is expected to drop below 5V, then sub-logic level threshold MOSFETs should be considered.

When the bottom MOSFET is used as the current sense element, particular attention must be paid to its on-resistance. MOSFET on-resistance is typically specified with a maximum value  $R_{DS(ON)(MAX)}$  at 25°C. In this case, additional margin is required to accommodate the rise in MOSFET on-resistance with temperature:

$$R_{DS(ON)(MAX)} = \frac{R_{SENSE}}{\rho_T}$$

The  $\rho_T$  term is a normalization factor (unity at 25°C) accounting for the significant variation in on-resistance

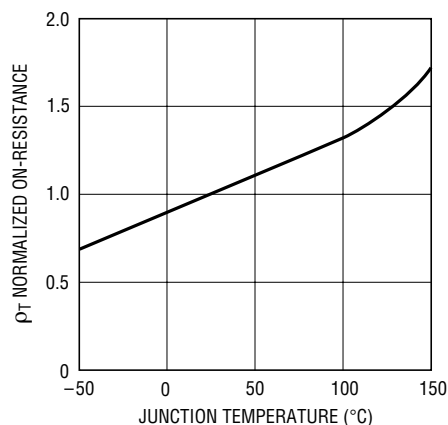

Figure 2.  $R_{DS(ON)}$  vs. Temperature

## APPLICATIONS INFORMATION

with temperature, typically about 0.4%/°C as shown in Figure 2. For a maximum junction temperature of 100°C, using a value  $\rho_T = 1.3$  is reasonable.

The power dissipated by the top and bottom MOSFETs strongly depends upon their respective duty cycles and the load current. When the LTC1778 is operating in continuous mode, the duty cycles for the MOSFETs are:

$$D_{TOP} = \frac{V_{OUT}}{V_{IN}}$$

$$D_{BOT} = \frac{V_{IN} - V_{OUT}}{V_{IN}}$$

The resulting power dissipation in the MOSFETs at maximum output current are:

$$P_{TOP} = D_{TOP} I_{OUT(MAX)}^2 \rho_{T(TOP)} R_{DS(ON)(MAX)} + k V_{IN}^2 I_{OUT(MAX)} C_{RSS} f$$

$$P_{BOT} = D_{BOT} I_{OUT(MAX)}^2 \rho_{T(BOT)} R_{DS(ON)(MAX)}$$

Both MOSFETs have  $I^2R$  losses and the top MOSFET includes an additional term for transition losses, which are largest at high input voltages. The constant  $k = 1.7A^{-1}$  can be used to estimate the amount of transition loss. The bottom MOSFET losses are greatest when the bottom duty cycle is near 100%, during a short-circuit or at high input voltage.

### Operating Frequency

The choice of operating frequency is a tradeoff between efficiency and component size. Low frequency operation improves efficiency by reducing MOSFET switching losses but requires larger inductance and/or capacitance in order to maintain low output ripple voltage.

The operating frequency of LTC1778 applications is determined implicitly by the one-shot timer that controls the on-time  $t_{ON}$  of the top MOSFET switch. The on-time is set by the current into the  $I_{ON}$  pin and the voltage at the  $V_{ON}$  pin (LTC1778-1) according to:

$$t_{ON} = \frac{V_{VON}}{I_{ION}} (10pF)$$

$V_{ON}$  defaults to 0.7V in the LTC1778.

Tying a resistor  $R_{ON}$  from  $V_{IN}$  to the  $I_{ON}$  pin yields an on-time inversely proportional to  $V_{IN}$ . For a step-down converter, this results in approximately constant frequency operation as the input supply varies:

$$f = \frac{V_{OUT}}{V_{VON} R_{ON}(10pF)} [Hz]$$

To hold frequency constant during output voltage changes, tie the  $V_{ON}$  pin to  $V_{OUT}$  or to a resistive divider from  $V_{OUT}$  when  $V_{OUT} > 2.4V$ . The  $V_{ON}$  pin has internal clamps that limit its input to the one-shot timer. If the pin is tied below 0.7V, the input to the one-shot is clamped at 0.7V. Similarly, if the pin is tied above 2.4V, the input is clamped at 2.4V. In high  $V_{OUT}$  applications, tying  $V_{ON}$  to  $INTV_{CC}$  so that the comparator input is 2.4V results in a lower value for  $R_{ON}$ . Figures 3a and 3b show how  $R_{ON}$  relates to switching frequency for several common output voltages.

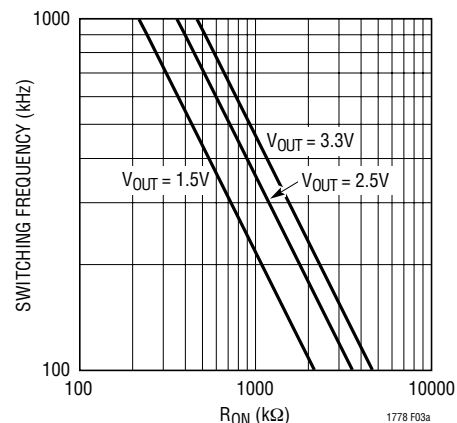

Figure 3a. Switching Frequency vs  $R_{ON}$  for the LTC1778 and LTC1778-1 ( $V_{ON} = 0V$ )

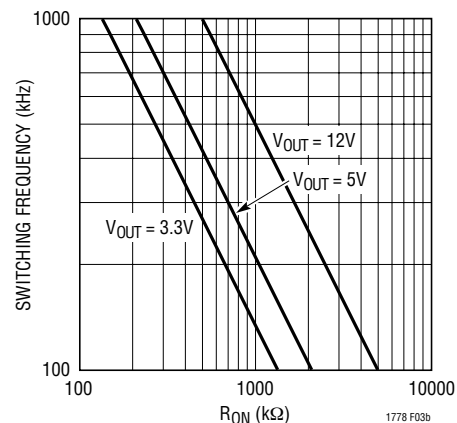

Figure 3b. Switching Frequency vs  $R_{ON}$  for the LTC1778-1 ( $V_{ON} = INTV_{CC}$ )

## APPLICATIONS INFORMATION

Because the voltage at the  $I_{ON}$  pin is about 0.7V, the current into this pin is not exactly inversely proportional to  $V_{IN}$ , especially in applications with lower input voltages. To correct for this error, an additional resistor  $R_{ON2}$  connected from the  $I_{ON}$  pin to the 5V  $INTV_{CC}$  supply will further stabilize the frequency.

$$R_{ON2} = \frac{5V}{0.7V} R_{ON}$$

Changes in the load current magnitude will also cause frequency shift. Parasitic resistance in the MOSFET switches and inductor reduce the effective voltage across the inductance, resulting in increased duty cycle as the load current increases. By lengthening the on-time slightly as current increases, constant frequency operation can be maintained. This is accomplished with a resistive divider from the  $I_{TH}$  pin to the  $V_{ON}$  pin and  $V_{OUT}$ . The values required will depend on the parasitic resistances in the specific application. A good starting point is to feed about 25% of the voltage change at the  $I_{TH}$  pin to the  $V_{ON}$  pin as shown in Figure 4a. Place capacitance on the  $V_{ON}$  pin to filter out the  $I_{TH}$  variations at the switching frequency. The resistor load on  $I_{TH}$  reduces the DC gain of the error amp and degrades load regulation, which can be avoided by using the PNP emitter follower of Figure 4b.

### Minimum Off-time and Dropout Operation

The minimum off-time  $t_{OFF(MIN)}$  is the smallest amount of time that the LTC1778 is capable of turning on the bottom MOSFET, tripping the current comparator and turning the MOSFET back off. This time is generally about 250ns. The minimum off-time limit imposes a maximum duty cycle of  $t_{ON}/(t_{ON} + t_{OFF(MIN)})$ . If the maximum duty cycle is reached,

due to a dropping input voltage for example, then the output will drop out of regulation. The minimum input voltage to avoid dropout is:

$$V_{IN(MIN)} = V_{OUT} \frac{t_{ON} + t_{OFF(MIN)}}{t_{ON}}$$

A plot of maximum duty cycle vs frequency is shown in Figure 5.

### Inductor Selection

Given the desired input and output voltages, the inductor value and operating frequency determine the ripple current:

$$\Delta I_L = \left( \frac{V_{OUT}}{f L} \right) \left( 1 - \frac{V_{OUT}}{V_{IN}} \right)$$

Lower ripple current reduces core losses in the inductor, ESR losses in the output capacitors and output voltage

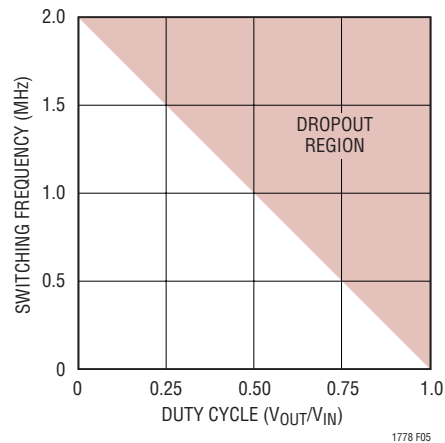
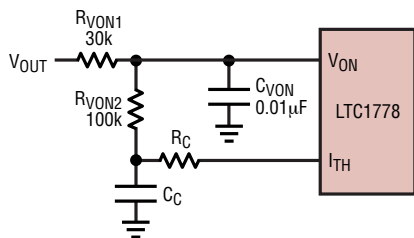
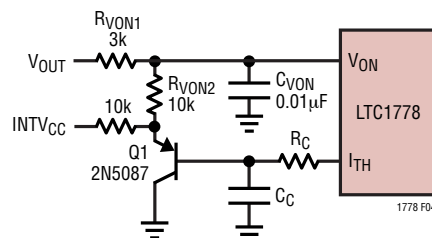

Figure 5. Maximum Switching Frequency vs Duty Cycle



(4a)



(4b)

Figure 4. Correcting Frequency Shift with Load Current Changes

## APPLICATIONS INFORMATION

ripple. Highest efficiency operation is obtained at low frequency with small ripple current. However, achieving this requires a large inductor. There is a tradeoff between component size, efficiency and operating frequency.

A reasonable starting point is to choose a ripple current that is about 40% of  $I_{OUT(MAX)}$ . The largest ripple current occurs at the highest  $V_{IN}$ . To guarantee that ripple current does not exceed a specified maximum, the inductance should be chosen according to:

$$L = \left( \frac{V_{OUT}}{f \Delta I_L(MAX)} \right) \left( 1 - \frac{V_{OUT}}{V_{IN(MAX)}} \right)$$

Once the value for L is known, the type of inductor must be selected. High efficiency converters generally cannot afford the core loss found in low cost powdered iron cores, forcing the use of more expensive ferrite, molypermalloy or Kool M $\mu$ <sup>®</sup> cores. A variety of inductors designed for high current, low voltage applications are available from manufacturers such as Sumida, Panasonic, Coiltronics, Coilcraft and Toko.

### Schottky Diode D1 Selection

The Schottky diode D1 shown in Figure 1 conducts during the dead time between the conduction of the power MOSFET switches. It is intended to prevent the body diode of the bottom MOSFET from turning on and storing charge during the dead time, which can cause a modest (about 1%) efficiency loss. The diode can be rated for about one half to one fifth of the full load current since it is on for only a fraction of the duty cycle. In order for the diode to be effective, the inductance between it and the bottom MOSFET must be as small as possible, mandating that these components be placed adjacently. The diode can be omitted if the efficiency loss is tolerable.

### C<sub>IN</sub> and C<sub>OUT</sub> Selection

The input capacitance  $C_{IN}$  is required to filter the square wave current at the drain of the top MOSFET. Use a low ESR capacitor sized to handle the maximum RMS current.

$$I_{RMS} \cong I_{OUT(MAX)} \frac{V_{OUT}}{V_{IN}} \sqrt{\frac{V_{IN}}{V_{OUT}} - 1}$$

This formula has a maximum at  $V_{IN} = 2V_{OUT}$ , where  $I_{RMS} = I_{OUT(MAX)}/2$ . This simple worst-case condition is commonly used for design because even significant deviations do not offer much relief. Note that ripple current ratings from capacitor manufacturers are often based on only 2000 hours of life which makes it advisable to derate the capacitor.

The selection of  $C_{OUT}$  is primarily determined by the ESR required to minimize voltage ripple and load step transients. The output ripple  $\Delta V_{OUT}$  is approximately bounded by:

$$\Delta V_{OUT} \leq \Delta I_L \left( ESR + \frac{1}{8fC_{OUT}} \right)$$

Since  $\Delta I_L$  increases with input voltage, the output ripple is highest at maximum input voltage. Typically, once the ESR requirement is satisfied, the capacitance is adequate for filtering and has the necessary RMS current rating.

Multiple capacitors placed in parallel may be needed to meet the ESR and RMS current handling requirements. Dry tantalum, special polymer, aluminum electrolytic and ceramic capacitors are all available in surface mount packages. Special polymer capacitors offer very low ESR but have lower capacitance density than other types. Tantalum capacitors have the highest capacitance density but it is important to only use types that have been surge tested for use in switching power supplies. Aluminum electrolytic capacitors have significantly higher ESR, but can be used in cost-sensitive applications providing that consideration is given to ripple current ratings and long term reliability. Ceramic capacitors have excellent low ESR characteristics but can have a high voltage coefficient and audible piezoelectric effects. The high Q of ceramic capacitors with trace inductance can also lead to significant ringing. When used as input capacitors, care must be taken to ensure that ringing from inrush currents and switching does not pose an overvoltage hazard to the power switches and controller. To dampen input voltage transients, add a small 5 $\mu$ F to 50 $\mu$ F aluminum electrolytic capacitor with an ESR in the range of 0.5 $\Omega$  to 2 $\Omega$ . High performance through-hole capacitors may also be used,

Kool M $\mu$  is a registered trademark of Magnetics, Inc.

## APPLICATIONS INFORMATION

but an additional ceramic capacitor in parallel is recommended to reduce the effect of their lead inductance.

### Top MOSFET Driver Supply ( $C_B$ , $D_B$ )

An external bootstrap capacitor  $C_B$  connected to the BOOST pin supplies the gate drive voltage for the topside MOSFET. This capacitor is charged through diode  $D_B$  from  $INTV_{CC}$  when the switch node is low. When the top MOSFET turns on, the switch node rises to  $V_{IN}$  and the BOOST pin rises to approximately  $V_{IN} + INTV_{CC}$ . The boost capacitor needs to store about 100 times the gate charge required by the top MOSFET. In most applications 0.1 $\mu$ F to 0.47 $\mu$ F, X5R or X7R dielectric capacitor is adequate.

### Discontinuous Mode Operation and FCB Pin

The FCB pin determines whether the bottom MOSFET remains on when current reverses in the inductor. Tying this pin above its 0.8V threshold enables discontinuous operation where the bottom MOSFET turns off when inductor current reverses. The load current at which current reverses and discontinuous operation begins depends on the amplitude of the inductor ripple current and will vary with changes in  $V_{IN}$ . Tying the FCB pin below the 0.8V threshold forces continuous synchronous operation, allowing current to reverse at light loads and maintaining high frequency operation.

In addition to providing a logic input to force continuous operation, the FCB pin provides a means to maintain a flyback winding output when the primary is operating in discontinuous mode. The secondary output  $V_{OUT2}$  is normally set as shown in Figure 6 by the turns ratio  $N$  of the

transformer. However, if the controller goes into discontinuous mode and halts switching due to a light primary load current, then  $V_{OUT2}$  will droop. An external resistor divider from  $V_{OUT2}$  to the FCB pin sets a minimum voltage  $V_{OUT2(MIN)}$  below which continuous operation is forced until  $V_{OUT2}$  has risen above its minimum.

$$V_{OUT2(MIN)} = 0.8V \left( 1 + \frac{R4}{R3} \right)$$

### Fault Conditions: Current Limit and Foldback

The maximum inductor current is inherently limited in a current mode controller by the maximum sense voltage. In the LTC1778, the maximum sense voltage is controlled by the voltage on the  $V_{RNG}$  pin. With valley current control, the maximum sense voltage and the sense resistance determine the maximum allowed inductor valley current. The corresponding output current limit is:

$$I_{LIMIT} = \frac{V_{SNS(MAX)}}{R_{DS(ON)} \rho T} + \frac{1}{2} \Delta I_L$$

The current limit value should be checked to ensure that  $I_{LIMIT(MIN)} > I_{OUT(MAX)}$ . The minimum value of current limit generally occurs with the largest  $V_{IN}$  at the highest ambient temperature, conditions that cause the largest power loss in the converter. Note that it is important to check for self-consistency between the assumed MOSFET junction temperature and the resulting value of  $I_{LIMIT}$  which heats the MOSFET switches.

Caution should be used when setting the current limit based upon the  $R_{DS(ON)}$  of the MOSFETs. The maximum current limit is determined by the minimum MOSFET on-resistance. Data sheets typically specify nominal and maximum values for  $R_{DS(ON)}$ , but not a minimum. A reasonable assumption is that the minimum  $R_{DS(ON)}$  lies the same amount below the typical value as the maximum lies above it. Consult the MOSFET manufacturer for further guidelines.

To further limit current in the event of a short circuit to ground, the LTC1778 includes foldback current limiting. If the output falls by more than 25%, then the maximum sense voltage is progressively lowered to about one sixth of its full value.

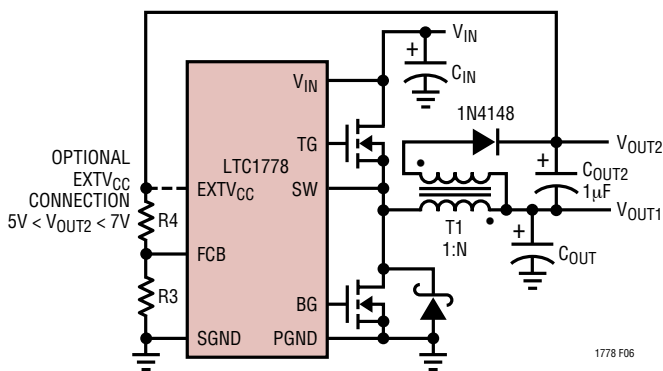

Figure 6. Secondary Output Loop and EXTV<sub>CC</sub> Connection

## APPLICATIONS INFORMATION

### INTV<sub>CC</sub> Regulator

An internal P-channel low dropout regulator produces the 5V supply that powers the drivers and internal circuitry within the LTC1778. The INTV<sub>CC</sub> pin can supply up to 50mA RMS and must be bypassed to ground with a minimum of 4.7μF low ESR tantalum capacitor. Good bypassing is necessary to supply the high transient currents required by the MOSFET gate drivers. Applications using large MOSFETs with a high input voltage and high frequency of operation may cause the LTC1778 to exceed its maximum junction temperature rating or RMS current rating. Most of the supply current drives the MOSFET gates unless an external EXTV<sub>CC</sub> source is used. In continuous mode operation, this current is  $I_{\text{GATECHG}} = f(Q_{\text{g(TOP)}} + Q_{\text{g(BOT)}})$ . The junction temperature can be estimated from the equations given in Note 2 of the Electrical Characteristics. For example, the LTC1778CGN is limited to less than 14mA from a 30V supply:

$$T_J = 70^\circ\text{C} + (14\text{mA})(30\text{V})(130^\circ\text{C/W}) = 125^\circ\text{C}$$

For larger currents, consider using an external supply with the EXTV<sub>CC</sub> pin.

### EXTV<sub>CC</sub> Connection

The EXTV<sub>CC</sub> pin can be used to provide MOSFET gate drive and control power from the output or another external source during normal operation. Whenever the EXTV<sub>CC</sub> pin is above 4.7V the internal 5V regulator is shut off and an internal 50mA P-channel switch connects the EXTV<sub>CC</sub> pin to INTV<sub>CC</sub>. INTV<sub>CC</sub> power is supplied from EXTV<sub>CC</sub> until this pin drops below 4.5V. Do not apply more than 7V to the EXTV<sub>CC</sub> pin and ensure that  $\text{EXTV}_{\text{CC}} \leq V_{\text{IN}}$ . The following list summarizes the possible connections for EXTV<sub>CC</sub>:

1. EXTV<sub>CC</sub> grounded. INTV<sub>CC</sub> is always powered from the internal 5V regulator.
2. EXTV<sub>CC</sub> connected to an external supply. A high efficiency supply compatible with the MOSFET gate drive requirements (typically 5V) can improve overall efficiency.
3. EXTV<sub>CC</sub> connected to an output derived boost network. The low voltage output can be boosted using a charge pump or flyback winding to greater than 4.7V. The system

will start-up using the internal linear regulator until the boosted output supply is available.

### External Gate Drive Buffers

The LTC1778 drivers are adequate for driving up to about 30nC into MOSFET switches with RMS currents of 50mA. Applications with larger MOSFET switches or operating at frequencies requiring greater RMS currents will benefit from using external gate drive buffers such as the LTC1693. Alternately, the external buffer circuit shown in Figure 7 can be used. Note that the bipolar devices reduce the signal swing at the MOSFET gate, and benefit from an increased EXTV<sub>CC</sub> voltage of about 6V.

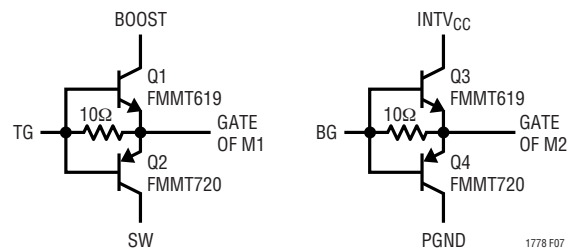

Figure 7. Optional External Gate Driver

### Soft-Start and Latchoff with the RUN/SS Pin

The RUN/SS pin provides a means to shut down the LTC1778 as well as a timer for soft-start and overcurrent latchoff. Pulling the RUN/SS pin below 0.8V puts the LTC1778 into a low quiescent current shutdown ( $I_Q < 30\mu\text{A}$ ). Releasing the pin allows an internal 1.2μA current source to charge up the external timing capacitor  $C_{\text{SS}}$ . If RUN/SS has been pulled all the way to ground, there is a delay before starting of about:

$$t_{\text{DELAY}} = \frac{1.5\text{V}}{1.2\mu\text{A}} C_{\text{SS}} = (1.3\text{s}/\mu\text{F}) C_{\text{SS}}$$

When the voltage on RUN/SS reaches 1.5V, the LTC1778 begins operating with a clamp on  $I_{\text{TH}}$  of approximately 0.9V. As the RUN/SS voltage rises to 3V, the clamp on  $I_{\text{TH}}$  is raised until its full 2.4V range is available. This takes an additional 1.3s/μF, during which the load current is folded back until the output reaches 75% of its final value. The pin can be driven from logic as shown in Figure 7. Diode D1



## APPLICATIONS INFORMATION

Other losses, including  $C_{OUT}$  ESR loss, Schottky diode D1 conduction loss during dead time and inductor core loss generally account for less than 2% additional loss.

When making adjustments to improve efficiency, the input current is the best indicator of changes in efficiency. If you make a change and the input current decreases, then the efficiency has increased. If there is no change in input current, then there is no change in efficiency.

### Checking Transient Response

The regulator loop response can be checked by looking at the load transient response. Switching regulators take several cycles to respond to a step in load current. When a load step occurs,  $V_{OUT}$  immediately shifts by an amount equal to  $\Delta I_{LOAD}$  (ESR), where ESR is the effective series resistance of  $C_{OUT}$ .  $\Delta I_{LOAD}$  also begins to charge or discharge  $C_{OUT}$  generating a feedback error signal used by the regulator to return  $V_{OUT}$  to its steady-state value. During this recovery time,  $V_{OUT}$  can be monitored for overshoot or ringing that would indicate a stability problem. The  $I_{TH}$  pin external components shown in Figure 9 will provide adequate compensation for most applications. For a detailed explanation of switching control loop theory see Application Note 76.

### Design Example

As a design example, take a supply with the following specifications:  $V_{IN} = 7V$  to  $28V$  (15V nominal),  $V_{OUT} = 2.5V \pm 5\%$ ,  $I_{OUT(MAX)} = 10A$ ,  $f = 250kHz$ . First, calculate the timing resistor with  $V_{ON} = V_{OUT}$ :

$$R_{ON} = \frac{2.5V}{(0.7V)(250kHz)(10pF)} = 1.42M\Omega$$

and choose the inductor for about 40% ripple current at the maximum  $V_{IN}$ :

$$L = \frac{2.5V}{(250kHz)(0.4)(10A)} \left(1 - \frac{2.5V}{28V}\right) = 2.3\mu H$$

Selecting a standard value of  $1.8\mu H$  results in a maximum ripple current of:

$$\Delta I_L = \frac{2.5V}{(250kHz)(1.8\mu H)} \left(1 - \frac{2.5V}{28V}\right) = 5.1A$$

Next, choose the synchronous MOSFET switch. Choosing a Si4874 ( $R_{DS(ON)} = 0.0083\Omega$  (NOM)  $0.010\Omega$  (MAX),  $\theta_{JA} = 40^\circ C/W$ ) yields a nominal sense voltage of:

$$V_{SNS(NOM)} = (10A)(1.3)(0.0083\Omega) = 108mV$$

Tying  $V_{RNG}$  to 1.1V will set the current sense voltage range for a nominal value of 110mV with current limit occurring at 146mV. To check if the current limit is acceptable, assume a junction temperature of about  $80^\circ C$  above a  $70^\circ C$  ambient with  $\rho_{150^\circ C} = 1.5$ :

$$I_{LIMIT} \geq \frac{146mV}{(1.5)(0.010\Omega)} + \frac{1}{2}(5.1A) = 12A$$

and double check the assumed  $T_J$  in the MOSFET:

$$P_{BOT} = \frac{28V - 2.5V}{28V} (12A)^2 (1.5)(0.010\Omega) = 1.97W$$

$$T_J = 70^\circ C + (1.97W)(40^\circ C/W) = 149^\circ C$$

Because the top MOSFET is on for such a short time, an Si4884  $R_{DS(ON)(MAX)} = 0.0165\Omega$ ,  $C_{RSS} = 100pF$ ,  $\theta_{JA} = 40^\circ C/W$  will be sufficient. Checking its power dissipation at current limit with  $\rho_{100^\circ C} = 1.4$ :

$$\begin{aligned} P_{TOP} &= \frac{2.5V}{28V} (12A)^2 (1.4)(0.0165\Omega) + \\ & (1.7)(28V)^2 (12A)(100pF)(250kHz) \\ &= 0.30W + 0.40W = 0.7W \end{aligned}$$

$$T_J = 70^\circ C + (0.7W)(40^\circ C/W) = 98^\circ C$$

The junction temperatures will be significantly less at nominal current, but this analysis shows that careful attention to heat sinking will be necessary in this circuit.

## APPLICATIONS INFORMATION

$C_{IN}$  is chosen for an RMS current rating of about 5A at 85°C. The output capacitors are chosen for a low ESR of 0.013Ω to minimize output voltage changes due to inductor ripple current and load steps. The ripple voltage will be only:

$$\begin{aligned} \Delta V_{OUT(RIPPLE)} &= \Delta I_{L(MAX)} (ESR) \\ &= (5.1A) (0.013\Omega) = 66mV \end{aligned}$$

However, a 0A to 10A load step will cause an output change of up to:

$$\Delta V_{OUT(STEP)} = \Delta I_{LOAD} (ESR) = (10A) (0.013\Omega) = 130mV$$

An optional 22μF ceramic output capacitor is included to minimize the effect of ESL in the output ripple. The complete circuit is shown in Figure 9.

### PC Board Layout Checklist

When laying out a PC board follow one of the two suggested approaches. The simple PC board layout requires a dedicated ground plane layer. Also, for higher currents, it is recommended to use a multilayer board to help with heat sinking power components.

- The ground plane layer should not have any traces and it should be as close as possible to the layer with power MOSFETs.
- Place  $C_{IN}$ ,  $C_{OUT}$ , MOSFETs, D1 and inductor all in one compact area. It may help to have some components on the bottom side of the board.
- Place LTC1778 chip with pins 9 to 16 facing the power components. Keep the components connected to pins 1 to 8 close to LTC1778 (noise sensitive components).
- Use an immediate via to connect the components to ground plane including SGND and PGND of LTC1778. Use several bigger vias for power components.
- Use compact plane for switch node (SW) to improve cooling of the MOSFETs and to keep EMI down.
- Use planes for  $V_{IN}$  and  $V_{OUT}$  to maintain good voltage filtering and to keep power losses low.
- Flood all unused areas on all layers with copper. Flooding with copper will reduce the temperature rise of power component. You can connect the copper areas to any DC net ( $V_{IN}$ ,  $V_{OUT}$ , GND or to any other DC rail in your system).

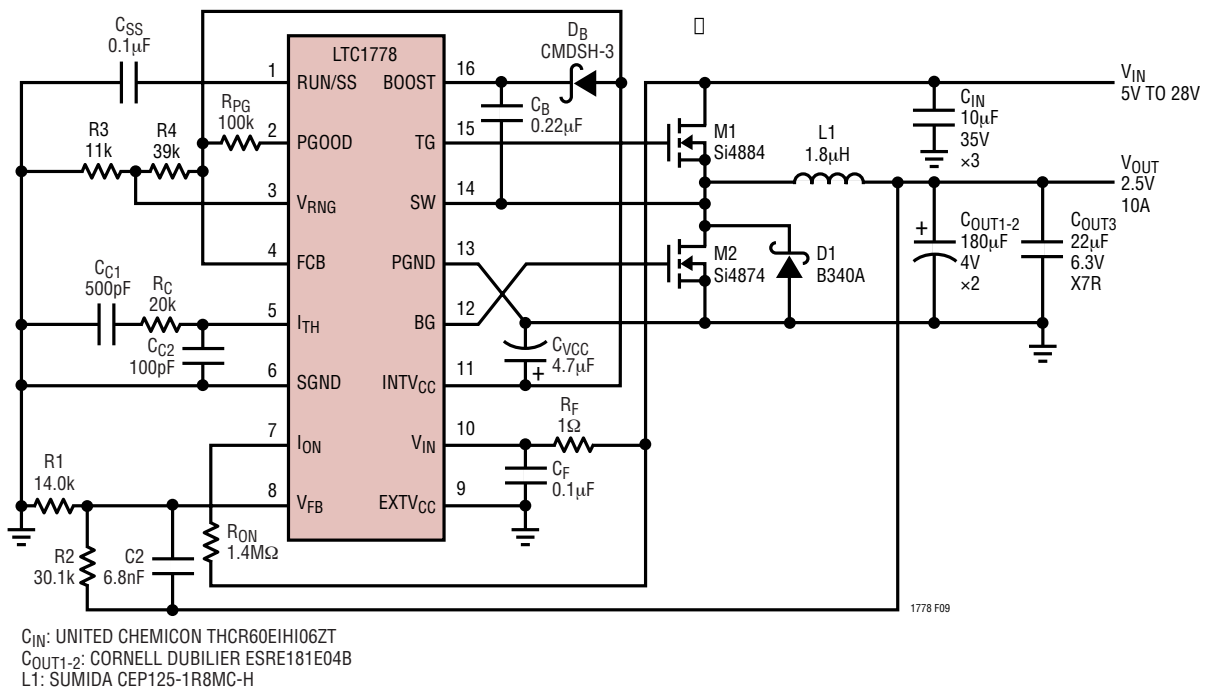
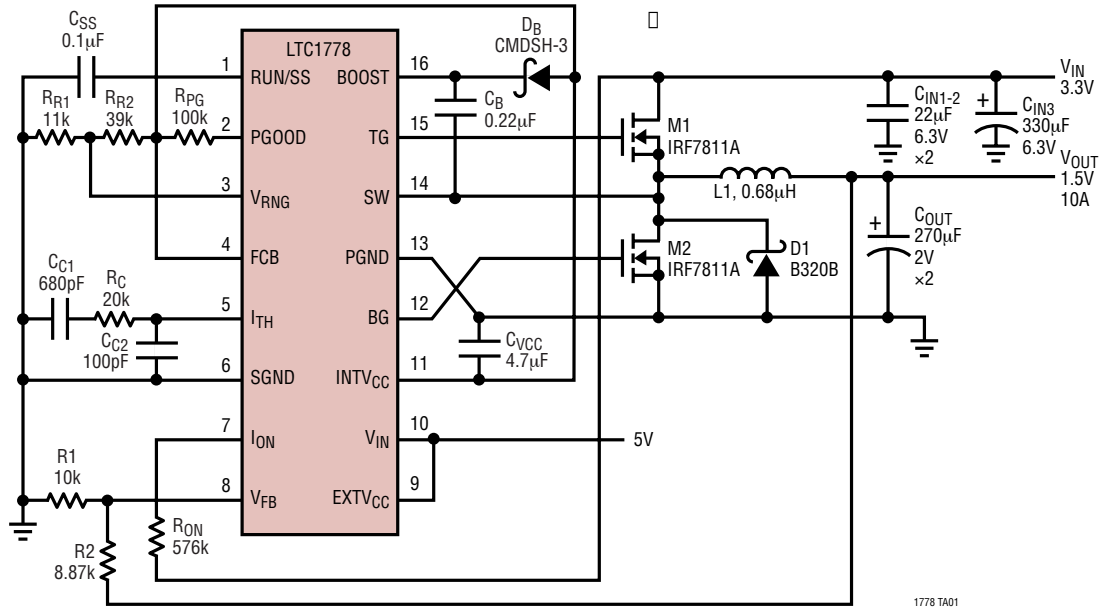

Figure 9. Design Example: 2.5V/10A at 250kHz



## TYPICAL APPLICATIONS

### 1.5V/10A at 300kHz from 3.3V Input



C<sub>IN1-2</sub>: MURATA GRM42-2X5R226K6.3  
 C<sub>OUT</sub>: CORNELL DUBILIER ESRE271M02B

### 1.2V/6A at 300kHz

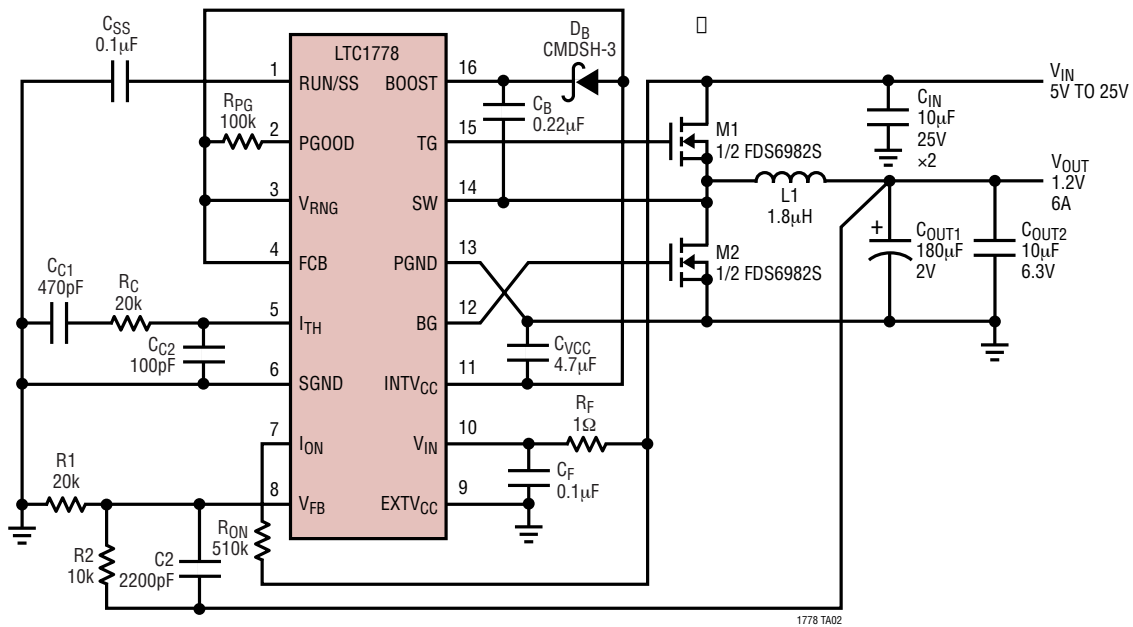

C<sub>IN</sub>: TAIYO YUDEN TMK432BJ106MM  
 C<sub>OUT1</sub>: CORNELL DUBILIER ESRD181M02B  
 C<sub>OUT2</sub>: TAIYO YUDEN JMK316BJ106ML  
 L1: TOKO 919AS-1R8N

# TYPICAL APPLICATIONS

## Single Inductor, Positive Output Buck/Boost

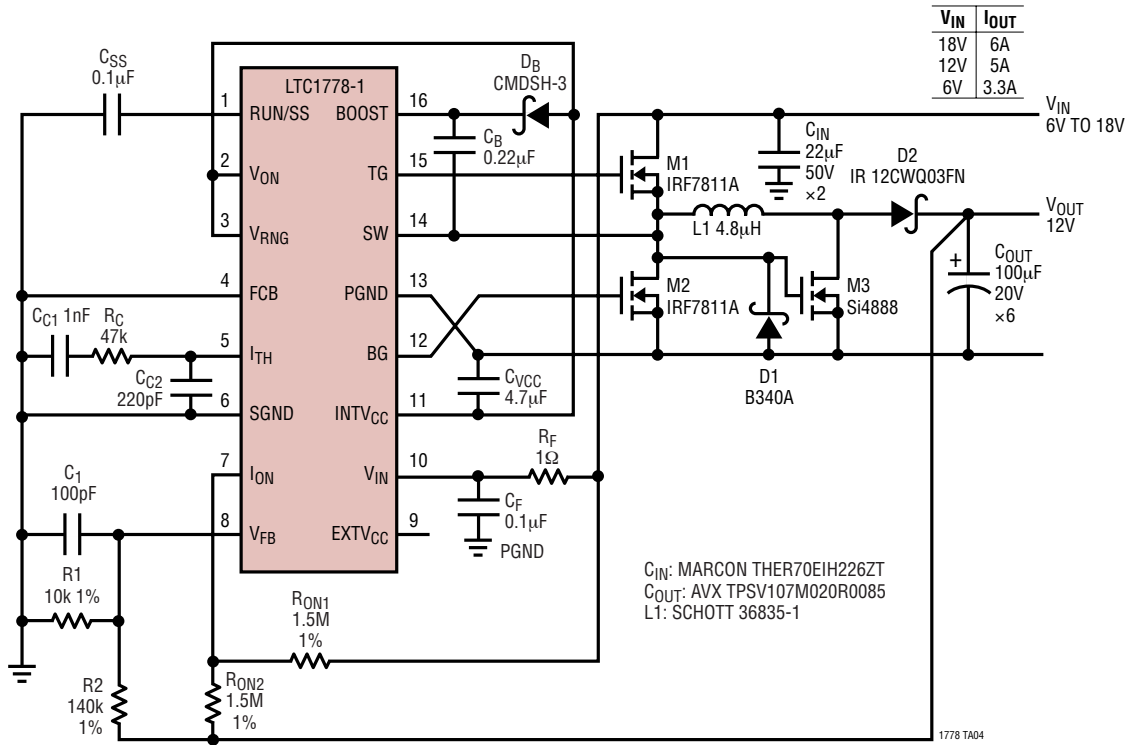

### 12V/5A at 300kHz

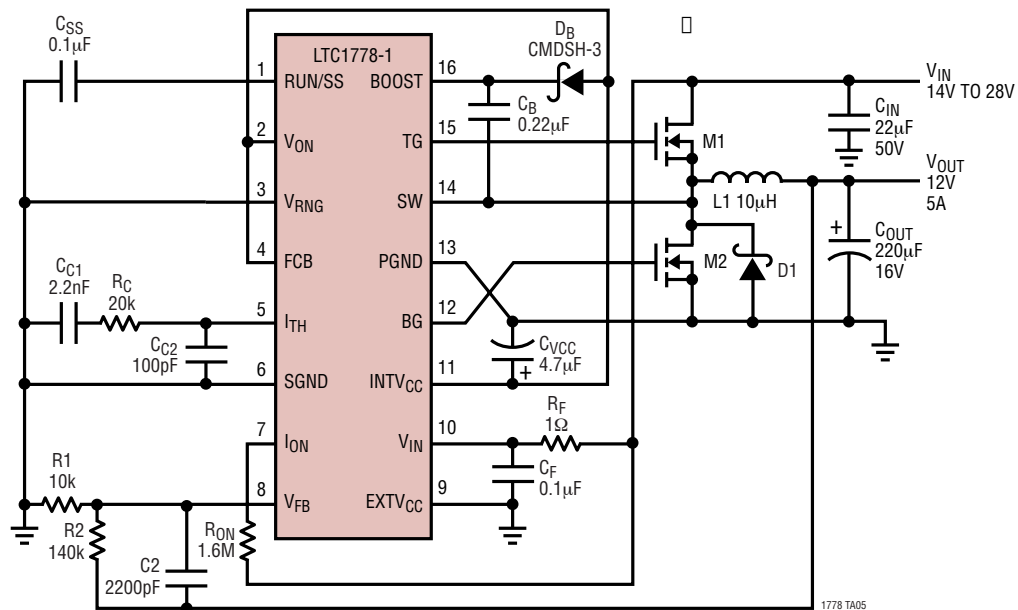

## TYPICAL APPLICATIONS

Positive-to-Negative Converter, -5V/5A at 300kHz

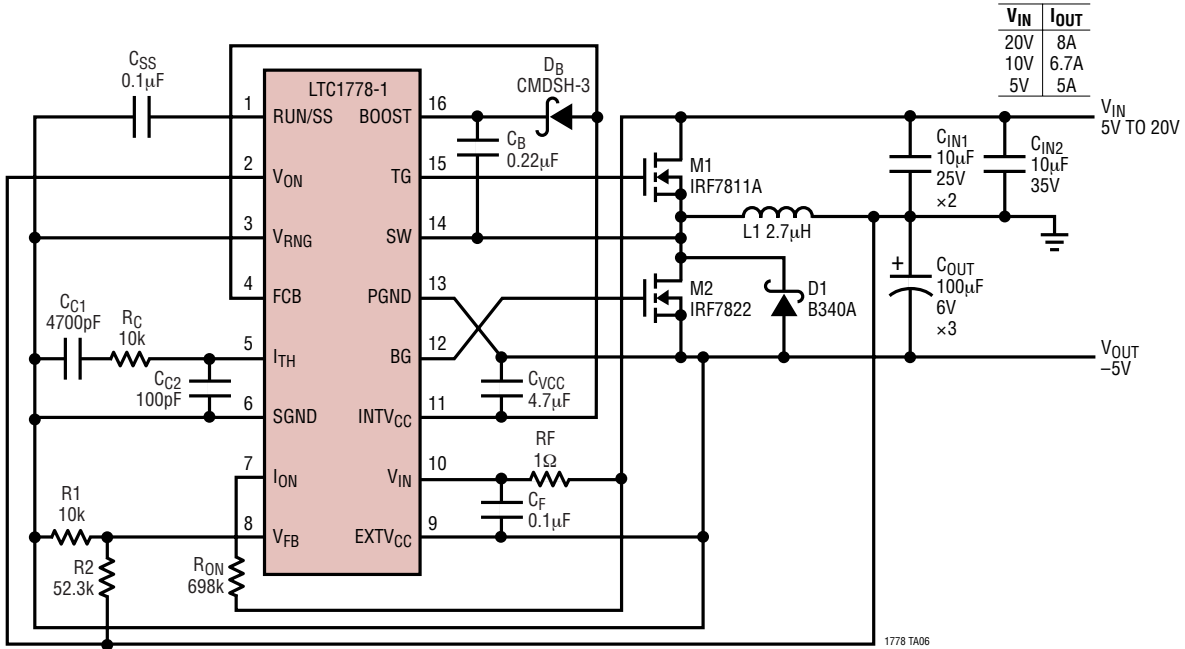

C<sub>IN1</sub>: TAIYO YUDEN TMK432BJ106MM  
 C<sub>IN2</sub>: SANYO 35CV10GX  
 C<sub>OUT</sub>: PANASONIC EEFUD0J101R  
 L1: PANASONIC ETQPAF2R7H

1778 TA06

# PACKAGE DESCRIPTION

## GN Package 16-Lead Plastic SSOP (Narrow 0.150) (LTC DWG # 05-08-1641)

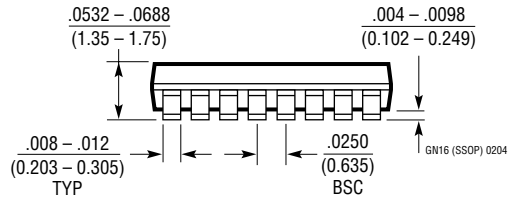
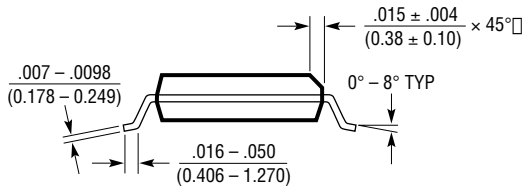
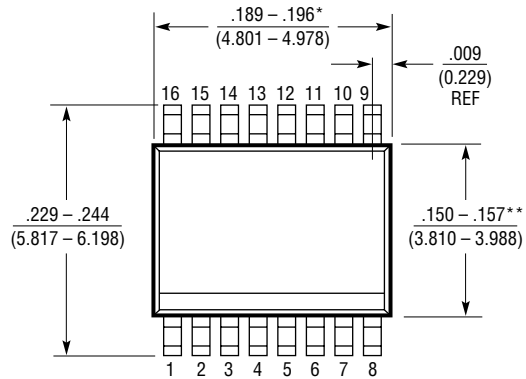
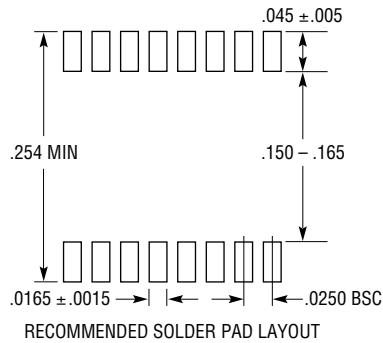

NOTE:

1. CONTROLLING DIMENSION: INCHES
2. DIMENSIONS ARE IN  $\frac{\text{INCHES}}{\text{MILLIMETERS}}$
3. DRAWING NOT TO SCALE

\*DIMENSION DOES NOT INCLUDE MOLD FLASH. MOLD FLASH SHALL NOT EXCEED 0.006" (0.152mm) PER SIDE

\*\*DIMENSION DOES NOT INCLUDE INTERLEAD FLASH. INTERLEAD FLASH SHALL NOT EXCEED 0.010" (0.254mm) PER SIDE

## TYPICAL APPLICATION

Typical Application 2.5V/3A at 1.4MHz

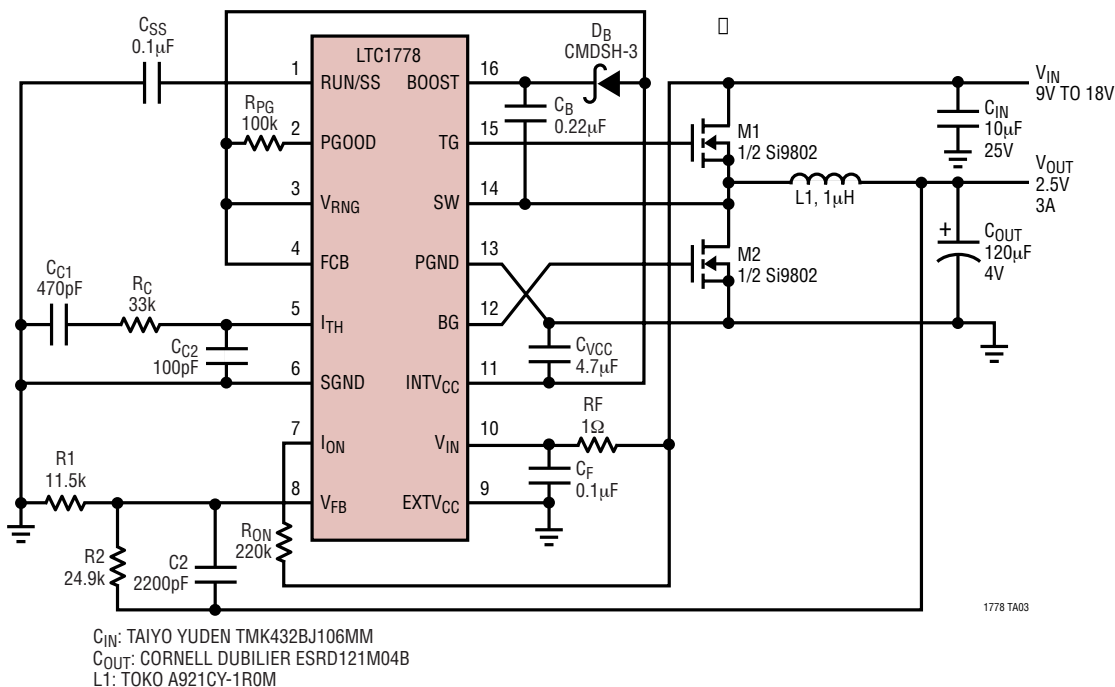

## RELATED PARTS

PART NUMBER	DESCRIPTION	COMMENTS
LTC1622	550kHz Step-Down Controller	8-Pin MSOP; Synchronizable; Soft-Start; Current Mode
LTC1625/LTC1775	No $R_{SENSE}$ Current Mode Synchronous Step-Down Controller	97% Efficiency; No Sense Resistor; 16-Pin SSOP
LTC1628-PG	Dual, 2-Phase Synchronous Step-Down Controller	Power Good Output; Minimum Input/Output Capacitors; $3.5V \leq V_{IN} \leq 36V$
LTC1628-SYNC	Dual, 2-Phase Synchronous Step-Down Controller	Synchronizable 150kHz to 300kHz
LTC1709-7	High Efficiency, 2-Phase Synchronous Step-Down Controller with 5-Bit VID	Up to 42A Output; $0.925V \leq V_{OUT} \leq 2V$
LTC1709-8	High Efficiency, 2-Phase Synchronous Step-Down Controller	Up to 42A Output; VRM 8.4; $1.3V \leq V_{OUT} \leq 3.5V$
LTC1735	High Efficiency, Synchronous Step-Down Controller	Burst Mode <sup>®</sup> Operation; 16-Pin Narrow SSOP; $3.5V \leq V_{IN} \leq 36V$
LTC1736	High Efficiency, Synchronous Step-Down Controller with 5-Bit VID	Mobile VID; $0.925V \leq V_{OUT} \leq 2V$ ; $3.5V \leq V_{IN} \leq 36V$
LTC1772	SOT-23 Step-Down Controller	Current Mode; 550kHz; Very Small Solution Size
LTC1773	Synchronous Step-Down Controller	Up to 95% Efficiency, 550kHz, $2.65V \leq V_{IN} \leq 8.5V$ , $0.8V \leq V_{OUT} \leq V_{IN}$ , Synchronizable to 750kHz
LTC1876	2-Phase, Dual Synchronous Step-Down Controller with Step-Up Regulator	$3.5V \leq V_{IN} \leq 36V$ , Power Good Output, 300kHz Operation
LTC3713	Low $V_{IN}$ High Current Synchronous Step-Down Controller	$1.5V \leq V_{IN} \leq 36V$ , $0.8V \leq V_{OUT} \leq (0.9)V_{IN}$ , $I_{OUT}$ Up to 20A
LTC3778	Low $V_{OUT}$ , No $R_{SENSE}$ Synchronous Step-Down Controller	$0.6V \leq V_{OUT} \leq (0.9)V_{IN}$ , $4V \leq V_{IN} \leq 36V$ , $I_{OUT}$ Up to 20A
LT <sup>®</sup> 3800	60V Synchronous Step-Down Controller	Current Mode, Output Slew Rate Control

Burst Mode is a registered trademark of Linear Technology Corporation.

## Looking for pricing, stock, or lifecycle information?

Click below to explore more details on WIN SOURCE:

 [View LTC1778EGN#TR on WIN SOURCE](#)

 [Linear Technology](#) Information

## Optimize Your Supply Chain with WIN SOURCE Solutions

-  Global Sourcing Solution
-  Obsolete Management
-  Cost Control Management
-  Shortage Management
-  Alternative Solution
-  Excess Inventory Management