



**THE DATASHEET OF
LTC1871IMS#TRPBF**



Wide Input Range, No R_{SENSE}^{TM} Current Mode Boost, Flyback and SEPIC Controller

FEATURES

- High Efficiency (No Sense Resistor Required)
- Wide Input Voltage Range: 2.5V to 36V
- Current Mode Control Provides Excellent Transient Response
- High Maximum Duty Cycle (92% Typ)
- $\pm 2\%$ RUN Pin Threshold with 100mV Hysteresis
- $\pm 1\%$ Internal Voltage Reference
- Micropower Shutdown: $I_Q = 10\mu A$
- Programmable Operating Frequency (50kHz to 1MHz) with One External Resistor
- Synchronizable to an External Clock Up to $1.3 \times f_{OSC}$
- User-Controlled Pulse Skip or Burst Mode[®] Operation
- Internal 5.2V Low Dropout Voltage Regulator
- Output Overvoltage Protection
- Capable of Operating with a Sense Resistor for High Output Voltage Applications
- Small 10-Lead MSOP Package

APPLICATIONS

- Telecom Power Supplies
- Portable Electronic Equipment

DESCRIPTION

The LTC[®]1871 is a wide input range, current mode, boost, flyback or SEPIC controller that drives an N-channel power MOSFET and requires very few external components. Intended for low to medium power applications, it eliminates the need for a current sense resistor by utilizing the power MOSFET's on-resistance, thereby maximizing efficiency.

The IC's operating frequency can be set with an external resistor over a 50kHz to 1MHz range, and can be synchronized to an external clock using the MODE/SYNC pin. Burst Mode operation at light loads, a low minimum operating supply voltage of 2.5V and a low shutdown quiescent current of 10 μA make the LTC1871 ideally suited for battery-operated systems.

For applications requiring constant frequency operation, Burst Mode operation can be defeated using the MODE/SYNC pin. Higher output voltage boost, SEPIC and flyback applications are possible with the LTC1871 by connecting the SENSE pin to a resistor in the source of the power MOSFET.

The LTC1871 is available in the 10-lead MSOP package.

LT, LT, LTC, LTM and Burst Mode are registered trademarks of Linear Technology Corporation. No R_{SENSE} is a trademark of Linear Technology Corporation. All other trademarks are the property of their respective owners.

TYPICAL APPLICATION

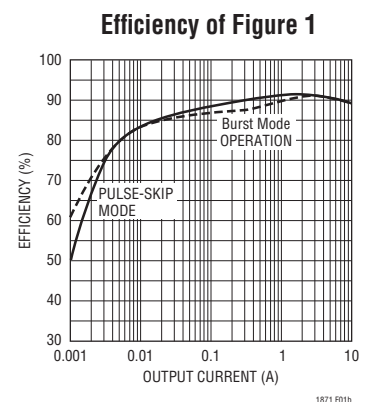
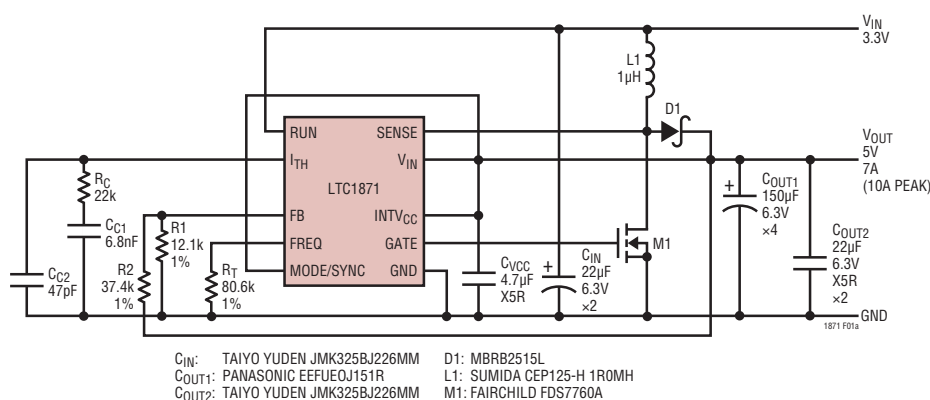

Figure 1. High Efficiency 3.3V Input, 5V Output Boost Converter (Bootstrapped)

LTC1871

ABSOLUTE MAXIMUM RATINGS

(Note 1)

| | |
|--------------------------------------------|------------------------------|
| V_{IN} Voltage | -0.3V to 36V |
| INTV _{CC} Voltage..... | -0.3V to 7V |
| INTV _{CC} Output Current..... | 50mA |
| GATE Voltage | -0.3V to $V_{INTVCC} + 0.3V$ |
| I_{TH} , FB Voltages | -0.3V to 2.7V |
| RUN, MODE/SYNC Voltages | -0.3V to 7V |
| FREQ Voltage | -0.3V to 1.5V |
| SENSE Pin Voltage..... | -0.3V to 36V |
| Operating Temperature Range (Note 2) | |
| LTC1871E..... | -40°C to 85°C |
| LTC1871I..... | -40°C to 125°C |
| LTC1871H | -40°C to 150°C |
| Junction Temperature (Note 3) | |
| LTC1871E/LTC1871I..... | 125°C |
| LTC1871H | 150°C |
| Storage Temperature Range..... | -65°C to 150°C |
| Lead Temperature (Soldering, 10 sec) | 300°C |

PIN CONFIGURATION

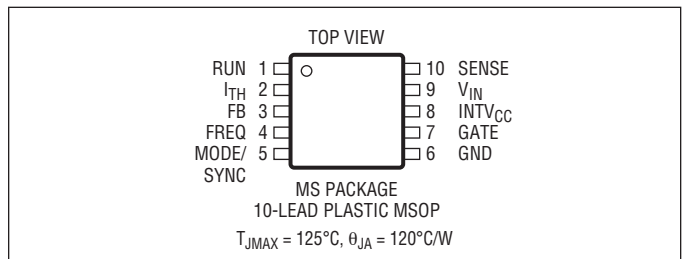

ORDER INFORMATION

| LEAD FREE FINISH | TAPE AND REEL | PART MARKING | PACKAGE DESCRIPTION | TEMPERATURE RANGE |
|-------------------|------------------|--------------|----------------------|-------------------|
| LTC1871EMS#PBF | LTC1871EMS#TRPBF | LTSX | 10-Lead Plastic MSOP | -40°C to 85°C |
| LTC1871IMS#PBF | LTC1871IMS#TRPBF | LTBFC | 10-Lead Plastic MSOP | -40°C to 125°C |
| LTC1871HMS#PBF | LTC1871HMS#TRPBF | LTCXS | 10-Lead Plastic MSOP | -40°C to 150°C |
| LEAD BASED FINISH | TAPE AND REEL | PART MARKING | PACKAGE DESCRIPTION | TEMPERATURE RANGE |
| LTC1871EMS | LTC1871EMS#TR | LTSX | 10-Lead Plastic MSOP | -40°C to 85°C |
| LTC1871IMS | LTC1871IMS#TR | LTBFC | 10-Lead Plastic MSOP | -40°C to 125°C |
| LTC1871HMS | LTC1871HMS#TR | LTCXS | 10-Lead Plastic MSOP | -40°C to 150°C |

Consult LTC Marketing for parts specified with wider operating temperature ranges.

For more information on lead free part marking, go to: <http://www.linear.com/leadfree/>

For more information on tape and reel specifications, go to: <http://www.linear.com/tapeandreel/>

ELECTRICAL CHARACTERISTICS The ● denotes the specifications which apply over the full operating temperature range, otherwise specifications are at $T_A = 25^\circ\text{C}$. $V_{IN} = V_{INTVCC} = 5\text{V}$, $V_{RUN} = 1.5\text{V}$, $R_{FREQ} = 80\text{k}$, $V_{MODE/SYNC} = 0\text{V}$, unless otherwise specified.

| SYMBOL | PARAMETER | CONDITIONS | MIN | TYP | MAX | UNITS | |
|-----------------------------------------------------|--------------------------------------------|---------------------------------------------------------------------------------------------------------------|-------|-------|---------------|-----------------|-----|
| Main Control Loop | | | | | | | |
| $V_{IN(MIN)}$ | Minimum Input Voltage | | | 2.5 | | V | |
| | | I-Grade or H-Grade (Note 2) | ● | 2.5 | | V | |
| I_Q | Input Voltage Supply Current | (Note 4) | | | | | |
| | Continuous Mode | $V_{MODE/SYNC} = 5\text{V}$, $V_{FB} = 1.4\text{V}$, $V_{ITH} = 0.75\text{V}$ | | 550 | 1000 | μA | |
| | | $V_{MODE/SYNC} = 5\text{V}$, $V_{FB} = 1.4\text{V}$, $V_{ITH} = 0.75\text{V}$, I-Grade or H-Grade (Note 2) | ● | 550 | 1000 | μA | |
| | Burst Mode Operation, No Load | $V_{MODE/SYNC} = 0\text{V}$, $V_{ITH} = 0.2\text{V}$ (Note 5) | | 250 | 500 | μA | |
| | | $V_{MODE/SYNC} = 0\text{V}$, $V_{ITH} = 0.2\text{V}$ (Note 5), I-Grade or H-Grade (Note 2) | ● | 250 | 500 | μA | |
| | Shutdown Mode | $V_{RUN} = 0\text{V}$ | | 10 | 20 | μA | |
| $V_{RUN} = 0\text{V}$, I-Grade or H-Grade (Note 2) | | ● | 10 | 20 | μA | | |
| V_{RUN}^+ | Rising RUN Input Threshold Voltage | | | 1.348 | | V | |
| V_{RUN}^- | Falling RUN Input Threshold Voltage | | 1.223 | 1.248 | 1.273 | V | |
| | | | 1.198 | | 1.298 | V | |
| | H-Grade (Note 2) | ● | 1.179 | | 1.315 | V | |
| $V_{RUN(HYST)}$ | RUN Pin Input Threshold Hysteresis | | 50 | 100 | 150 | mV | |
| | | I-Grade (Note 2) | ● | 35 | 100 | 175 | mV |
| | | H-Grade (Note 2) | ● | 35 | | 300 | mV |
| I_{RUN} | RUN Input Current | | | 1 | 60 | nA | |
| V_{FB} | Feedback Voltage | $V_{ITH} = 0.2\text{V}$ (Note 5) | ● | 1.218 | 1.230 | 1.242 | V |
| | | $V_{ITH} = 0.2\text{V}$ (Note 5), I-Grade or H-Grade (Note 2) | ● | 1.212 | | 1.248 | V |
| | | $V_{ITH} = 0.2\text{V}$ (Note 5), I-Grade or H-Grade (Note 2) | ● | 1.205 | | 1.255 | V |
| I_{FB} | FB Pin Input Current | $V_{ITH} = 0.2\text{V}$ (Note 5) | | 18 | 60 | nA | |
| $\frac{\Delta V_{FB}}{\Delta V_{IN}}$ | Line Regulation | $2.5\text{V} \leq V_{IN} \leq 30\text{V}$ | | 0.002 | 0.02 | %/V | |
| | | $2.5\text{V} \leq V_{IN} \leq 30\text{V}$, I-Grade or H-Grade (Note 2) | ● | 0.002 | 0.02 | %/V | |
| $\frac{\Delta V_{FB}}{\Delta V_{ITH}}$ | Load Regulation | $V_{MODE/SYNC} = 0\text{V}$, $V_{ITH} = 0.5\text{V}$ to 0.9V (Note 5) | ● | -1 | -0.1 | % | |
| | | $V_{MODE/SYNC} = 0\text{V}$, $V_{ITH} = 0.5\text{V}$ to 0.9V (Note 5), I-Grade or H-Grade (Note 2) | ● | -1 | -0.1 | % | |
| $\Delta V_{FB(OV)}$ | ΔFB Pin, Overvoltage Lockout | $V_{FB(OV)} - V_{FB(NOM)}$ in Percent | | 2.5 | 6 | 10 | % |
| g_m | Error Amplifier Transconductance | I_{TH} Pin Load = $\pm 5\mu\text{A}$ (Note 5) | | 650 | | μmho | |
| $V_{ITH(BURST)}$ | Burst Mode Operation I_{TH} Pin Voltage | Falling I_{TH} Voltage (Note 5) | | 0.3 | | V | |
| $V_{SENSE(MAX)}$ | Maximum Current Sense Input Threshold | Duty Cycle < 20% | | 120 | 150 | 180 | mV |
| | | Duty Cycle < 20%, I-Grade or H-Grade (Note 2) | ● | 100 | | 200 | mV |
| $I_{SENSE(ON)}$ | SENSE Pin Current (GATE High) | $V_{SENSE} = 0\text{V}$ | | 35 | 50 | μA | |
| $I_{SENSE(OFF)}$ | SENSE Pin Current (GATE Low) | $V_{SENSE} = 30\text{V}$ | | 0.1 | 5 | μA | |
| Oscillator | | | | | | | |
| f_{OSC} | Oscillator Frequency | $R_{FREQ} = 80\text{k}$ | | 250 | 300 | 350 | kHz |
| | | $R_{FREQ} = 80\text{k}$, I-Grade (Note 2) | ● | 250 | 300 | 350 | kHz |
| | | $R_{FREQ} = 80\text{k}$, H-Grade (Note 2) | ● | 240 | 300 | 360 | kHz |
| | Oscillator Frequency Range | | | 50 | 1000 | kHz | |
| | | I-Grade or H-Grade (Note 2) | ● | 50 | 1000 | kHz | |

ELECTRICAL CHARACTERISTICS

The ● denotes the specifications which apply over the full operating temperature range, otherwise specifications are at $T_A = 25^\circ\text{C}$. $V_{IN} = V_{INTVCC} = 5\text{V}$, $V_{RUN} = 1.5\text{V}$, $R_{FREQ} = 80\text{k}$, $V_{MODE/SYNC} = 0\text{V}$, unless otherwise specified.

| SYMBOL | PARAMETER | CONDITIONS | MIN | TYP | MAX | UNITS |
|--------------------|--------------------------------------------------|-----------------------------------------------------------------|-------|---------------|------|------------------|
| D_{MAX} | Maximum Duty Cycle | | 87 | 92 | 97 | % |
| | | I-Grade or H-Grade (Note 2) | ● 87 | 92 | 97 | % |
| f_{SYNC}/f_{OSC} | Recommended Maximum Synchronized Frequency Ratio | $f_{OSC} = 300\text{kHz}$ (Note 6) | | 1.25 | 1.30 | |
| | | $f_{OSC} = 300\text{kHz}$ (Note 6), I-Grade or H-Grade (Note 2) | ● | 1.25 | 1.30 | |
| $t_{SYNC(MIN)}$ | MODE/SYNC Minimum Input Pulse Width | $V_{SYNC} = 0\text{V}$ to 5V | | 25 | | ns |
| $t_{SYNC(MAX)}$ | MODE/SYNC Maximum Input Pulse Width | $V_{SYNC} = 0\text{V}$ to 5V | | $0.8/f_{OSC}$ | | ns |
| $V_{IL(MODE)}$ | Low Level MODE/SYNC Input Voltage | | | | 0.3 | V |
| | | I-Grade or H-Grade (Note 2) | ● | | 0.3 | V |
| $V_{IH(MODE)}$ | High Level MODE/SYNC Input Voltage | | 1.2 | | | V |
| | | I-Grade or H-Grade (Note 2) | ● 1.2 | | | V |
| $R_{MODE/SYNC}$ | MODE/SYNC Input Pull-Down Resistance | | | 50 | | $\text{k}\Omega$ |
| V_{FREQ} | Nominal FREQ Pin Voltage | | | 0.62 | | V |

Low Dropout Regulator

| | | | | | | | |
|--------------------------------------------|--------------------------------------------------------------|---------------------------------------------------------------|---|------|------|---------------|---|
| V_{INTVCC} | INTV _{CC} Regulator Output Voltage | $V_{IN} = 7.5\text{V}$ | | 5.0 | 5.2 | 5.4 | V |
| | | $V_{IN} = 7.5\text{V}$, I-Grade (Note 2) | ● | 5.0 | 5.2 | 5.4 | V |
| | | $V_{IN} = 7.5\text{V}$, H-Grade (Note 2) | ● | 4.95 | 5.2 | 5.45 | V |
| $\frac{\Delta V_{INTVCC}}{\Delta V_{IN1}}$ | INTV _{CC} Regulator Line Regulation | $7.5\text{V} \leq V_{IN} \leq 15\text{V}$ | | 8 | 25 | mV | |
| $\frac{\Delta V_{INTVCC}}{\Delta V_{IN2}}$ | INTV _{CC} Regulator Line Regulation | $15\text{V} \leq V_{IN} \leq 30\text{V}$ | | 70 | 200 | mV | |
| $V_{LDO(LOAD)}$ | INTV _{CC} Load Regulation | $0 \leq I_{INTVCC} \leq 20\text{mA}$, $V_{IN} = 7.5\text{V}$ | | -2 | -0.2 | % | |
| $V_{DROPOUT}$ | INTV _{CC} Regulator Dropout Voltage | $V_{IN} = 5\text{V}$, INTV _{CC} Load = 20mA | | 280 | | mV | |
| I_{INTVCC} | Bootstrap Mode INTV _{CC} Supply Current in Shutdown | $RUN = 0\text{V}$, SENSE = 5V | | 10 | 20 | μA | |
| | | I-Grade (Note 2) | ● | | 30 | μA | |
| | | H-Grade (Note 2) | ● | | 50 | μA | |

GATE Driver

| | | | | | | |
|-------|------------------------------|--------------------------------|--|----|-----|----|
| t_r | GATE Driver Output Rise Time | $C_L = 3300\text{pF}$ (Note 7) | | 17 | 100 | ns |
| t_f | GATE Driver Output Fall Time | $C_L = 3300\text{pF}$ (Note 7) | | 8 | 100 | ns |

Note 1: Stresses beyond those listed under Absolute Maximum Ratings may cause permanent damage to the device. Exposure to any Absolute Maximum Rating condition for extended periods may affect device reliability and lifetime.

Note 2: The LTC1871E is guaranteed to meet performance specifications from 0°C to 85°C operating temperature. Specifications over the -40°C to 85°C operating temperature range are assured by design, characterization and correlation with statistical process controls. The LTC1871I is guaranteed over the full -40°C to 125°C operating temperature range and the LTC1871H is guaranteed over the full -40°C to 150°C operating temperature range.

Note 3: T_J is calculated from the ambient temperature T_A and power dissipation P_D according to the following formula:

$$T_J = T_A + (P_D \cdot 110^\circ\text{C/W})$$

Note 4: The dynamic input supply current is higher due to power MOSFET gate charging ($Q_G \cdot f_{OSC}$). See Applications Information.

Note 5: The LTC1871 is tested in a feedback loop which servos V_{FB} to the reference voltage with the I_{TH} pin forced to the midpoint of its voltage range ($0.3\text{V} \leq V_{ITH} \leq 1.2\text{V}$, midpoint = 0.75V).

Note 6: In a synchronized application, the internal slope compensation gain is increased by 25%. Synchronizing to a significantly higher ratio will reduce the effective amount of slope compensation, which could result in subharmonic oscillation for duty cycles greater than 50%.

Note 7: Rise and fall times are measured at 10% and 90% levels.

TYPICAL PERFORMANCE CHARACTERISTICS

FB Voltage vs Temp

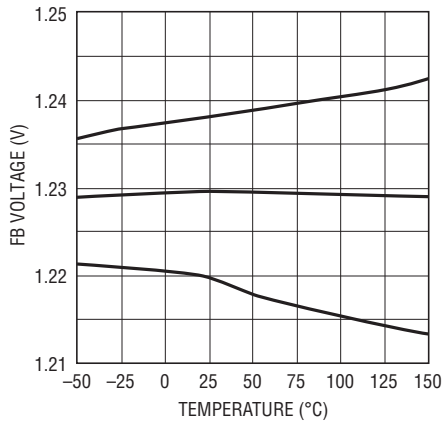

1871 G01

FB Voltage Line Regulation

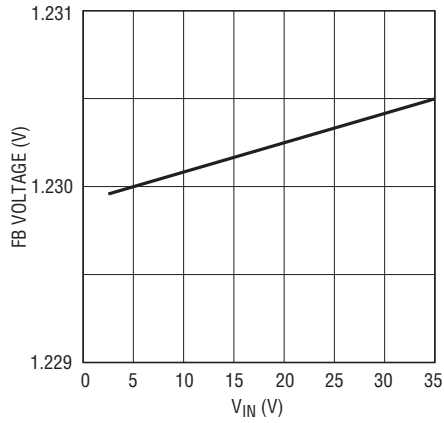

1871 G02

FB Pin Current vs Temperature

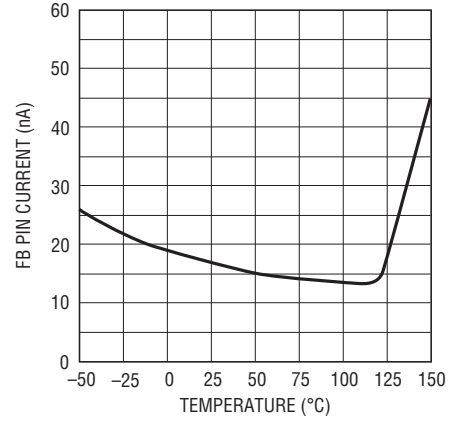

1871 G03

Shutdown Mode I_Q vs V_{IN}

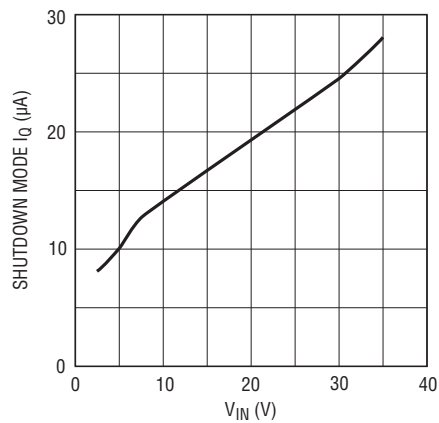

1871 G04

Shutdown Mode I_Q vs Temperature

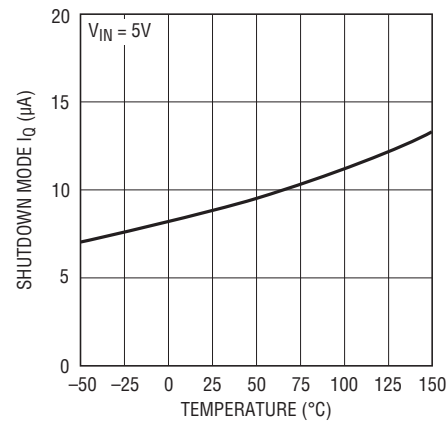

1871 G05

Burst Mode I_Q vs V_{IN}

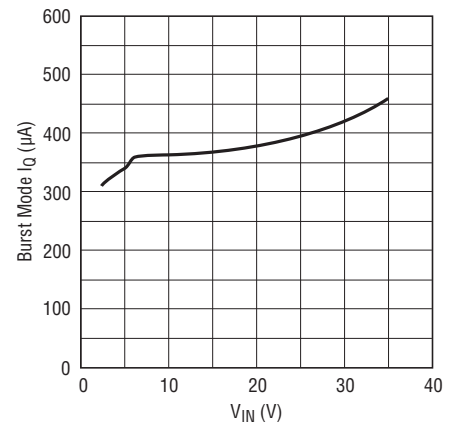

1871 G06

Burst Mode I_Q vs Temperature

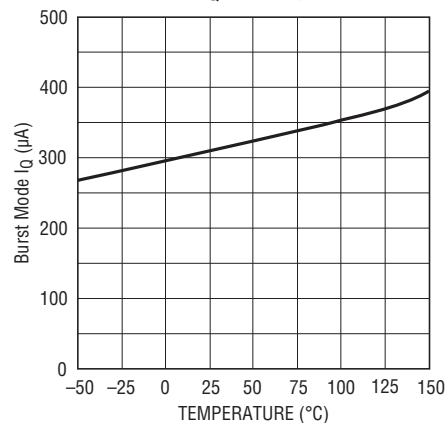

1871 G07

Dynamic I_Q vs Frequency

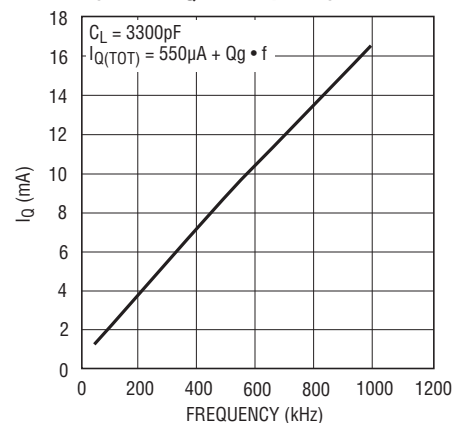

1871 G08

Gate Drive Rise and Fall Time vs C_L

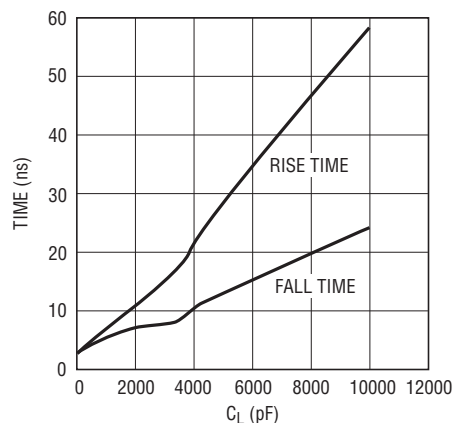

1871 G09

TYPICAL PERFORMANCE CHARACTERISTICS

RUN Thresholds vs V_{IN}

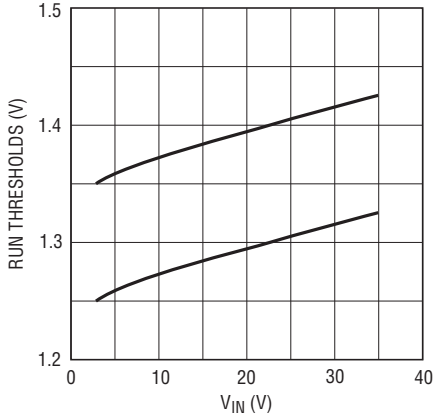

RUN Thresholds vs Temperature

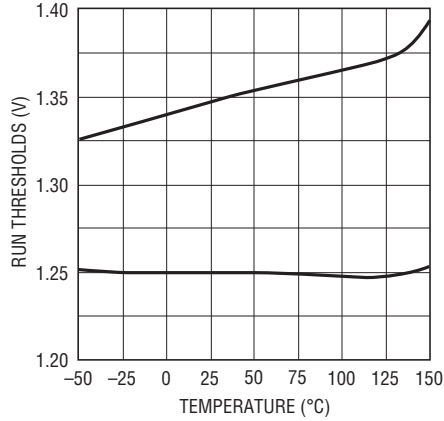

R_T vs Frequency

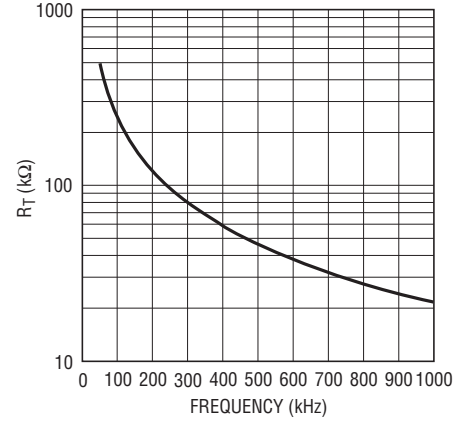

Frequency vs Temperature

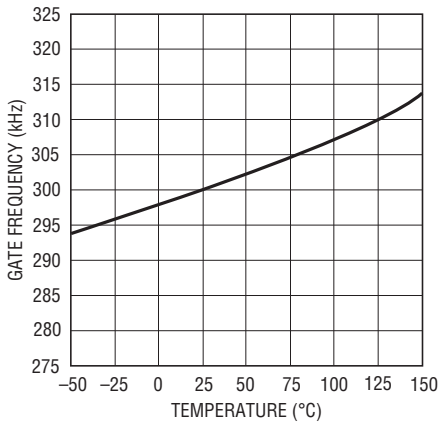

Maximum Sense Threshold vs Temperature

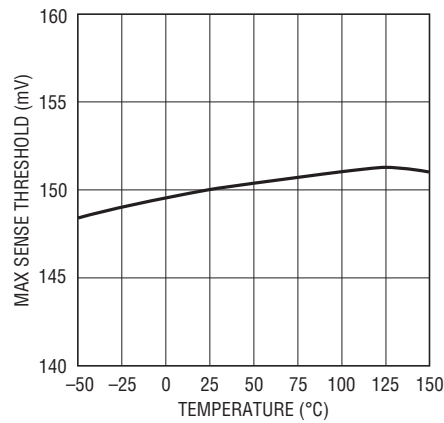

SENSE Pin Current vs Temperature

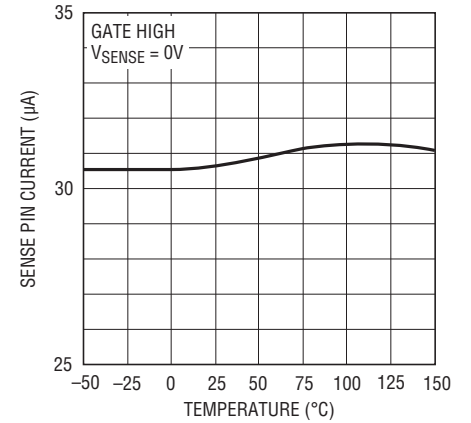

INTV_{CC} Load Regulation

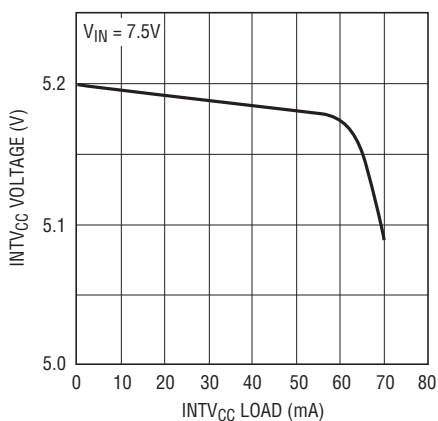

INTV_{CC} Line Regulation

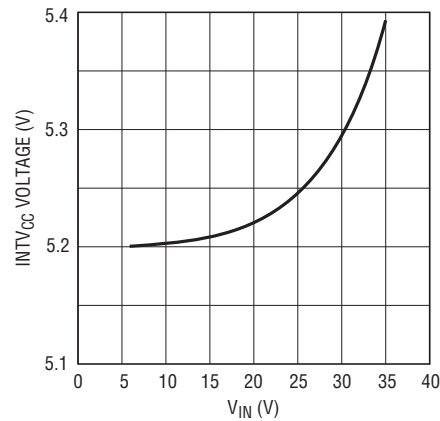

INTV_{CC} Dropout Voltage vs Current, Temperature

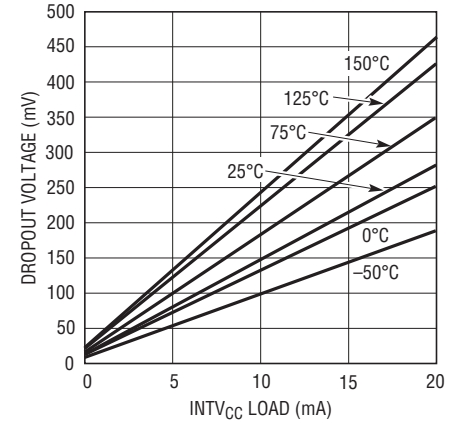

PIN FUNCTIONS

RUN (Pin 1): The RUN pin provides the user with an accurate means for sensing the input voltage and programming the start-up threshold for the converter. The falling RUN pin threshold is nominally 1.248V and the comparator has 100mV of hysteresis for noise immunity. When the RUN pin is below this input threshold, the IC is shut down and the V_{IN} supply current is kept to a low value (typ 10 μ A). The Absolute Maximum Rating for the voltage on this pin is 7V.

I_{TH} (Pin 2): Error Amplifier Compensation Pin. The current comparator input threshold increases with this control voltage. Nominal voltage range for this pin is 0V to 1.40V.

FB (Pin 3): Receives the feedback voltage from the external resistor divider across the output. Nominal voltage for this pin in regulation is 1.230V.

FREQ (Pin 4): A resistor from the FREQ pin to ground programs the operating frequency of the chip. The nominal voltage at the FREQ pin is 0.6V.

MODE/SYNC (Pin 5): This input controls the operating mode of the converter and allows for synchronizing the

operating frequency to an external clock. If the MODE/SYNC pin is connected to ground, Burst Mode operation is enabled. If the MODE/SYNC pin is connected to INTV_{CC}, or if an external logic-level synchronization signal is applied to this input, Burst Mode operation is disabled and the IC operates in a continuous mode.

GND (Pin 6): Ground Pin.

GATE (Pin 7): Gate Driver Output.

INTV_{CC} (Pin 8): The Internal 5.20V Regulator Output. The gate driver and control circuits are powered from this voltage. Decouple this pin locally to the IC ground with a minimum of 4.7 μ F low ESR tantalum or ceramic capacitor.

V_{IN} (Pin 9): Main Supply Pin. Must be closely decoupled to ground.

SENSE (Pin 10): The Current Sense Input for the Control Loop. Connect this pin to the drain of the power MOSFET for V_{DS} sensing and highest efficiency. Alternatively, the SENSE pin may be connected to a resistor in the source of the power MOSFET. Internal leading edge blanking is provided for both sensing methods.

BLOCK DIAGRAM

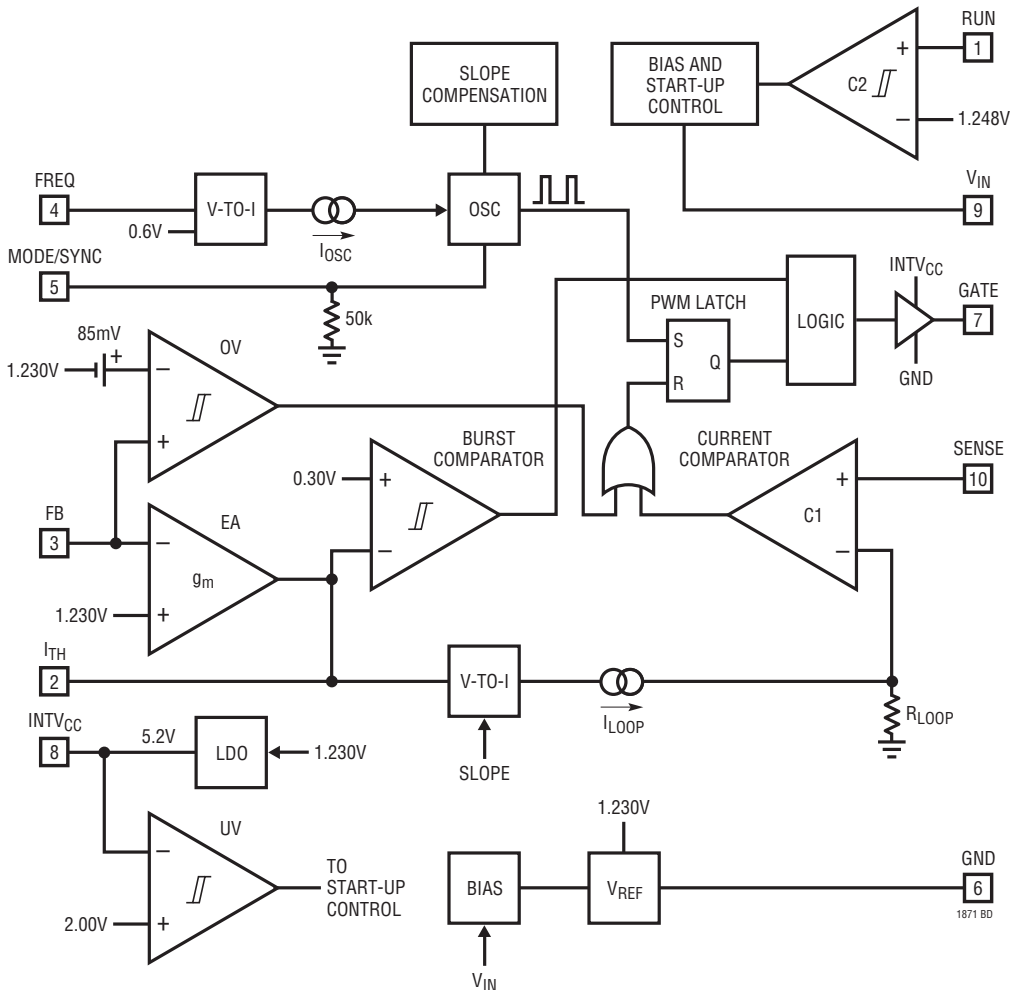

OPERATION

Main Control Loop

The LTC1871 is a constant frequency, current mode controller for DC/DC boost, SEPIC and flyback converter applications. The LTC1871 is distinguished from conventional current mode controllers because the current control loop can be closed by sensing the voltage drop across the power MOSFET switch instead of across a discrete sense resistor, as shown in Figure 2. This sensing technique improves efficiency, increases power density, and reduces the cost of the overall solution.

For circuit operation, please refer to the Block Diagram of the IC and Figure 1. In normal operation, the power MOSFET

is turned on when the oscillator sets the PWM latch and is turned off when the current comparator C1 resets the latch. The divided-down output voltage is compared to an internal 1.230V reference by the error amplifier EA, which outputs an error signal at the I_{TH} pin. The voltage on the I_{TH} pin sets the current comparator C1 input threshold. When the load current increases, a fall in the FB voltage relative to the reference voltage causes the I_{TH} pin to rise, which causes the current comparator C1 to trip at a higher peak inductor current value. The average inductor current will therefore rise until it equals the load current, thereby maintaining output regulation.

OPERATION

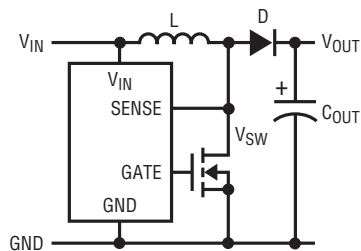

2a. SENSE Pin Connection for Maximum Efficiency ($V_{SW} < 36V$)

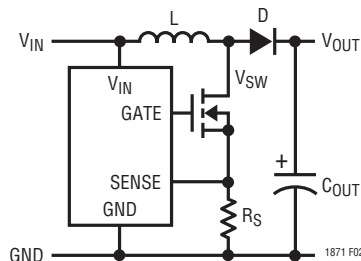

2b. SENSE Pin Connection for Precise Control of Peak Current or for $V_{SW} > 36V$

Figure 2. Using the SENSE Pin On the LTC1871

The nominal operating frequency of the LTC1871 is programmed using a resistor from the FREQ pin to ground and can be controlled over a 50kHz to 1000kHz range. In addition, the internal oscillator can be synchronized to an external clock applied to the MODE/SYNC pin and can be locked to a frequency between 100% and 130% of its nominal value. When the MODE/SYNC pin is left open, it is pulled low by an internal 50k resistor and Burst Mode operation is enabled. If this pin is taken above 2V or an external clock is applied, Burst Mode operation is disabled and the IC operates in continuous mode. With no load (or an extremely light load), the controller will skip pulses in order to maintain regulation and prevent excessive output ripple.

The RUN pin controls whether the IC is enabled or is in a low current shutdown state. A micropower 1.248V reference and comparator C2 allow the user to program the supply voltage at which the IC turns on and off (comparator C2 has 100mV of hysteresis for noise immunity). With the RUN pin below 1.248V, the chip is off and the input supply current is typically only 10 μ A.

An overvoltage comparator OV senses when the FB pin exceeds the reference voltage by 6.5% and provides a

reset pulse to the main RS latch. Because this RS latch is reset-dominant, the power MOSFET is actively held off for the duration of an output overvoltage condition.

The LTC1871 can be used either by sensing the voltage drop across the power MOSFET or by connecting the SENSE pin to a conventional shunt resistor in the source of the power MOSFET, as shown in Figure 2. Sensing the voltage across the power MOSFET maximizes converter efficiency and minimizes the component count, but limits the output voltage to the maximum rating for this pin (36V). By connecting the SENSE pin to a resistor in the source of the power MOSFET, the user is able to program output voltages significantly greater than 36V.

Programming the Operating Mode

For applications where maximizing the efficiency at very light loads (e.g., <100 μ A) is a high priority, the current in the output divider could be decreased to a few microamps and Burst Mode operation should be applied (i.e., the MODE/SYNC pin should be connected to ground). In applications where fixed frequency operation is more critical than low current efficiency, or where the lowest output ripple is desired, pulse-skip mode operation should be used and the MODE/SYNC pin should be connected to the INTV_{CC} pin. This allows discontinuous conduction mode (DCM) operation down to near the limit defined by the chip's minimum on-time (about 175ns). Below this output current level, the converter will begin to skip cycles in order to maintain output regulation. Figures 3 and 4 show the light load switching waveforms for Burst Mode and pulse-skip mode operation for the converter in Figure 1.

Burst Mode Operation

Burst Mode operation is selected by leaving the MODE/SYNC pin unconnected or by connecting it to ground. In normal operation, the range on the I_{TH} pin corresponding to no load to full load is 0.30V to 1.2V. In Burst Mode operation, if the error amplifier EA drives the I_{TH} voltage below 0.525V, the buffered I_{TH} input to the current comparator C1 will be clamped at 0.525V (which corresponds to 25% of maximum load current). The inductor current peak is then held at approximately 30mV divided by the power

OPERATION

MOSFET $R_{DS(ON)}$. If the I_{TH} pin drops below 0.30V, the Burst Mode comparator B1 will turn off the power MOSFET and scale back the quiescent current of the IC to 250 μ A (sleep mode). In this condition, the load current will be supplied by the output capacitor until the I_{TH} voltage rises above the 50mV hysteresis of the burst comparator. At light loads, short bursts of switching (where the average inductor current is 20% of its maximum value) followed by long periods of sleep will be observed, thereby greatly improving converter efficiency. Oscilloscope waveforms illustrating Burst Mode operation are shown in Figure 3.

Pulse-Skip Mode Operation

With the MODE/SYNC pin tied to a DC voltage above 2V, Burst Mode operation is disabled. The internal, 0.525V buffered I_{TH} burst clamp is removed, allowing the I_{TH} pin to directly control the current comparator from no load to full load. With no load, the I_{TH} pin is driven below 0.30V, the power MOSFET is turned off and sleep mode is invoked. Oscilloscope waveforms illustrating this mode of operation are shown in Figure 4.

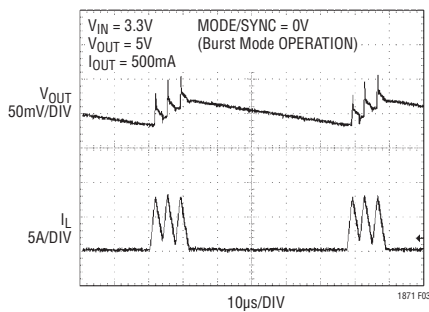

Figure 3. LTC1871 Burst Mode Operation (MODE/SYNC = 0V) at Low Output Current

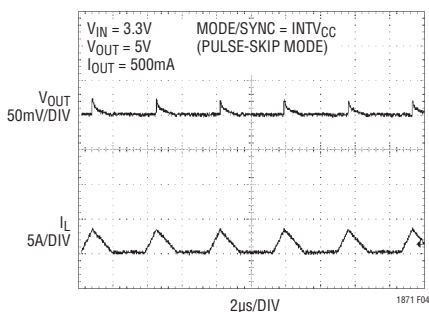

Figure 4. LTC1871 Low Output Current Operation with Burst Mode Operation Disabled (MODE/SYNC = INTV_{CC})

When an external clock signal drives the MODE/SYNC pin at a rate faster than the chip's internal oscillator, the oscillator will synchronize to it. In this synchronized mode, Burst Mode operation is disabled. The constant frequency associated with synchronized operation provides a more controlled noise spectrum from the converter, at the expense of overall system efficiency of light loads.

When the oscillator's internal logic circuitry detects a synchronizing signal on the MODE/SYNC pin, the internal oscillator ramp is terminated early and the slope compensation is increased by approximately 30%. As a result, in applications requiring synchronization, it is recommended that the nominal operating frequency of the IC be programmed to be about 75% of the external clock frequency. Attempting to synchronize to too high an external frequency (above $1.3f_0$) can result in inadequate slope compensation and possible subharmonic oscillation (or jitter).

The external clock signal must exceed 2V for at least 25ns, and should have a maximum duty cycle of 80%, as shown in Figure 5. The MOSFET turn on will synchronize to the rising edge of the external clock signal.

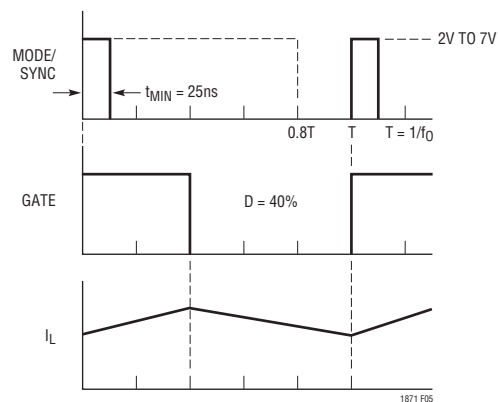

Figure 5. MODE/SYNC Clock Input and Switching Waveforms for Synchronized Operation

APPLICATIONS INFORMATION

Programming the Operating Frequency

The choice of operating frequency and inductor value is a tradeoff between efficiency and component size. Low frequency operation improves efficiency by reducing MOSFET and diode switching losses. However, lower frequency operation requires more inductance for a given amount of load current.

The LTC1871 uses a constant frequency architecture that can be programmed over a 50kHz to 1000kHz range with a single external resistor from the FREQ pin to ground, as shown in Figure 1. The nominal voltage on the FREQ pin is 0.6V, and the current that flows into the FREQ pin is used to charge and discharge an internal oscillator capacitor. A graph for selecting the value of R_T for a given operating frequency is shown in Figure 6.

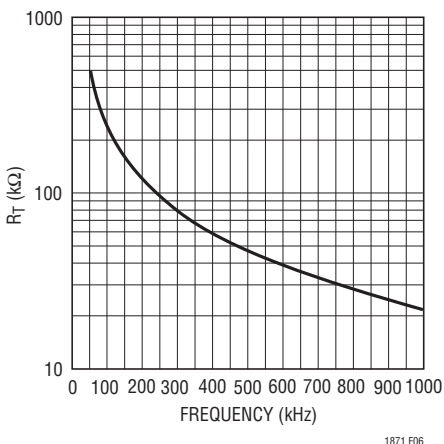

Figure 6. Timing Resistor (R_T) Value

INTV_{CC} Regulator Bypassing and Operation

An internal, P-channel low dropout voltage regulator produces the 5.2V supply which powers the gate driver and logic circuitry within the LTC1871, as shown in Figure 7. The INTV_{CC} regulator can supply up to 50mA and must be bypassed to ground immediately adjacent to the IC pins with a minimum of 4.7 μ F tantalum or ceramic capacitor. Good bypassing is necessary to supply the high transient currents required by the MOSFET gate driver.

For input voltages that don't exceed 7V (the absolute maximum rating for this pin), the internal low dropout regulator in the LTC1871 is redundant and the INTV_{CC} pin can be shorted directly to the V_{IN} pin. With the INTV_{CC} pin shorted to V_{IN} , however, the divider that programs the regulated INTV_{CC} voltage will draw 10 μ A of current from the input supply, even in shutdown mode. For applications that require the lowest shutdown mode input supply current, do not connect the INTV_{CC} pin to V_{IN} . Regardless of whether the INTV_{CC} pin is shorted to V_{IN} or not, **it is always necessary to have the driver circuitry bypassed with a 4.7 μ F tantalum or low ESR ceramic capacitor to ground immediately adjacent to the INTV_{CC} and GND pins.**

In an actual application, most of the IC supply current is used to drive the gate capacitance of the power MOSFET. As a result, high input voltage applications in which a large power MOSFET is being driven at high frequencies can cause the LTC1871 to exceed its maximum junction

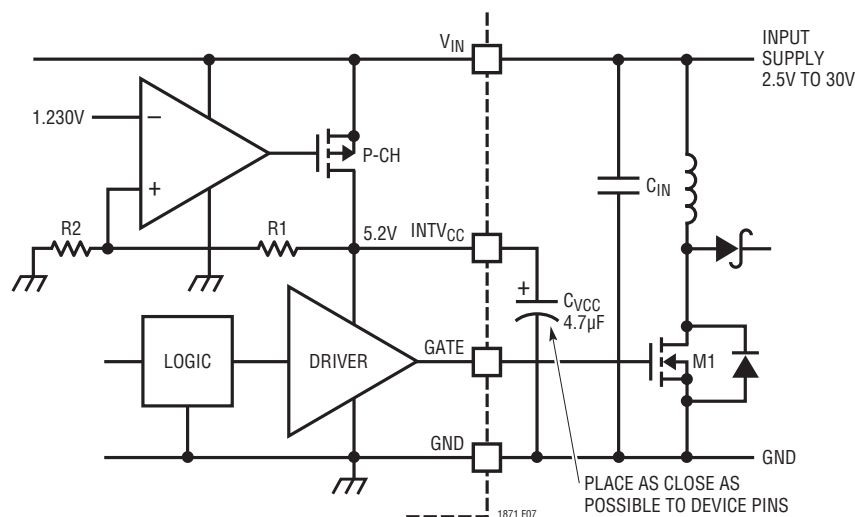

Figure 7. Bypassing the LDO Regulator and Gate Driver Supply

APPLICATIONS INFORMATION

temperature rating. The junction temperature can be estimated using the following equations:

$$I_{Q(TOT)} \approx I_Q + f \cdot Q_G$$

$$P_{IC} = V_{IN} \cdot (I_Q + f \cdot Q_G)$$

$$T_J = T_A + P_{IC} \cdot R_{TH(JA)}$$

The total quiescent current $I_{Q(TOT)}$ consists of the static supply current (I_Q) and the current required to charge and discharge the gate of the power MOSFET. The 10-pin MSOP package has a thermal resistance of $R_{TH(JA)} = 120^\circ\text{C/W}$.

As an example, consider a power supply with $V_{IN} = 5\text{V}$ and $V_O = 12\text{V}$ at $I_O = 1\text{A}$. The switching frequency is 500kHz , and the maximum ambient temperature is 70°C . The power MOSFET chosen is the IRF7805, which has a maximum $R_{DS(ON)}$ of $11\text{m}\Omega$ (at room temperature) and a maximum total gate charge of 37nC (the temperature coefficient of the gate charge is low).

$$I_{Q(TOT)} = 600\mu\text{A} + 37\text{nC} \cdot 500\text{kHz} = 19.1\text{mA}$$

$$P_{IC} = 5\text{V} \cdot 19.1\text{mA} = 95\text{mW}$$

$$T_J = 70^\circ\text{C} + 120^\circ\text{C/W} \cdot 95\text{mW} = 81.4^\circ\text{C}$$

This demonstrates how significant the gate charge current can be when compared to the static quiescent current in the IC.

To prevent the maximum junction temperature from being exceeded, the input supply current must be checked when operating in a continuous mode at high V_{IN} . A tradeoff between the operating frequency and the size of the power MOSFET may need to be made in order to maintain a reliable IC junction temperature. Prior to lowering the operating frequency, however, be sure to check with power MOSFET manufacturers for their latest-and-greatest low Q_G , low $R_{DS(ON)}$ devices. Power MOSFET manufacturing technologies are continually improving, with newer and better performance devices being introduced almost yearly.

Output Voltage Programming

The output voltage is set by a resistor divider according to the following formula:

$$V_O = 1.230\text{V} \cdot \left(1 + \frac{R_2}{R_1}\right)$$

The external resistor divider is connected to the output as shown in Figure 1, allowing remote voltage sensing. The resistors R_1 and R_2 are typically chosen so that the error caused by the current flowing into the FB pin during normal operation is less than 1% (this translates to a maximum value of R_1 of about 250k).

Programming Turn-On and Turn-Off Thresholds with the RUN Pin

The LTC1871 contains an independent, micropower voltage reference and comparator detection circuit that remains active even when the device is shut down, as shown in Figure 8. This allows users to accurately program an input voltage at which the converter will turn on and off. The falling threshold voltage on the RUN pin is equal to the internal reference voltage of 1.248V . The comparator has 100mV of hysteresis to increase noise immunity.

The turn-on and turn-off input voltage thresholds are programmed using a resistor divider according to the following formulas:

$$V_{IN(OFF)} = 1.248\text{V} \cdot \left(1 + \frac{R_2}{R_1}\right)$$

$$V_{IN(ON)} = 1.348\text{V} \cdot \left(1 + \frac{R_2}{R_1}\right)$$

The resistor R_1 is typically chosen to be less than 1M .

For applications where the RUN pin is only to be used as a logic input, the user should be aware of the 7V Absolute Maximum Rating for this pin! The RUN pin can be connected to the input voltage through an external 1M resistor, as shown in Figure 8c, for “always on” operation.

Application Circuits

A basic LTC1871 application circuit is shown in Figure 1. External component selection is driven by the characteristics of the load and the input supply. The first topology to be analyzed will be the boost converter, followed by SEPIC (single ended primary inductance converter).

APPLICATIONS INFORMATION

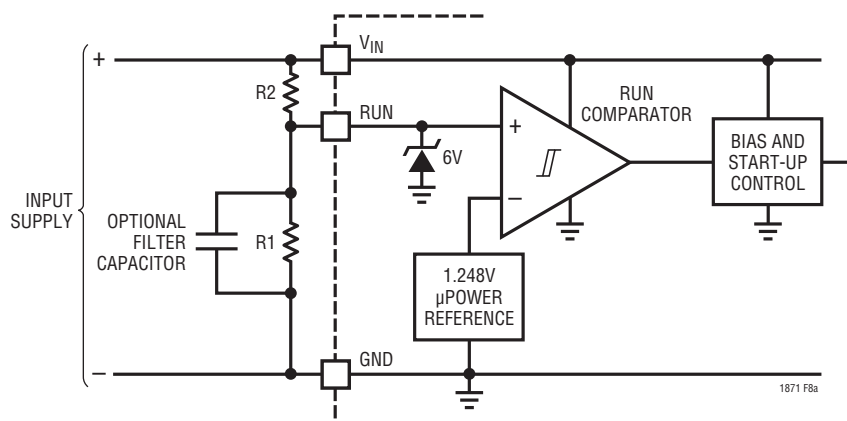

Figure 8a. Programming the Turn-On and Turn-Off Thresholds Using the RUN Pin

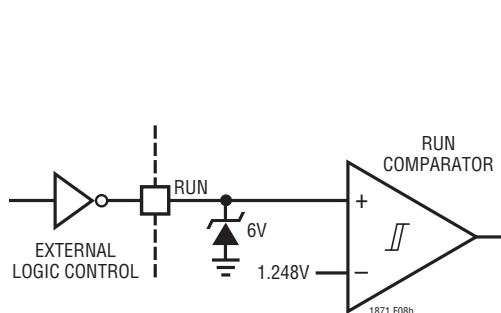

Figure 8b. On/Off Control Using External Logic

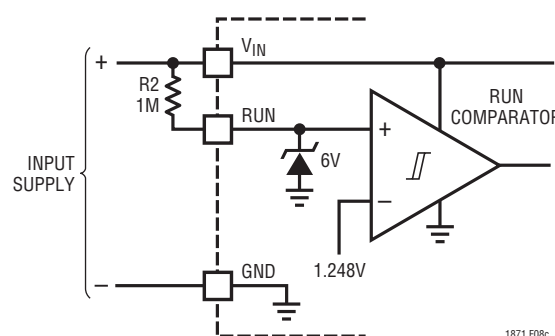

Figure 8c. External Pull-Up Resistor On RUN Pin for "Always On" Operation

Boost Converter: Duty Cycle Considerations

For a boost converter operating in a continuous conduction mode (CCM), the duty cycle of the main switch is:

$$D = \left(\frac{V_O + V_D - V_{IN}}{V_O + V_D} \right)$$

where V_D is the forward voltage of the boost diode. For converters where the input voltage is close to the output voltage, the duty cycle is low and for converters that develop a high output voltage from a low voltage input supply, the duty cycle is high. The maximum output voltage for a boost converter operating in CCM is:

$$V_{O(MAX)} = \frac{V_{IN(MIN)}}{(1 - D_{MAX})} - V_D$$

The maximum duty cycle capability of the LTC1871 is typically 92%. This allows the user to obtain high output voltages from low input supply voltages.

Boost Converter: The Peak and Average Input Currents

The control circuit in the LTC1871 is measuring the input current (either by using the $R_{DS(ON)}$ of the power MOSFET or by using a sense resistor in the MOSFET source), so the output current needs to be reflected back to the input in order to dimension the power MOSFET properly. Based on the fact that, ideally, the output power is equal to the input power, the maximum average input current is:

$$I_{IN(MAX)} = \frac{I_{O(MAX)}}{1 - D_{MAX}}$$

The peak input current is:

$$I_{IN(PEAK)} = \left(1 + \frac{\chi}{2} \right) \cdot \frac{I_{O(MAX)}}{1 - D_{MAX}}$$

The maximum duty cycle, D_{MAX} , should be calculated at minimum V_{IN} .

APPLICATIONS INFORMATION

Boost Converter: Ripple Current ΔI_L and the ' χ ' Factor

The constant ' χ ' in the equation above represents the percentage peak-to-peak ripple current in the inductor, relative to its maximum value. For example, if 30% ripple current is chosen, then $\chi = 0.30$, and the peak current is 15% greater than the average.

For a current mode boost regulator operating in CCM, slope compensation must be added for duty cycles above 50% in order to avoid subharmonic oscillation. For the LTC1871, this ramp compensation is internal. Having an internally fixed ramp compensation waveform, however, does place some constraints on the value of the inductor and the operating frequency. If too large an inductor is used, the resulting current ramp (ΔI_L) will be small relative to the internal ramp compensation (at duty cycles above 50%), and the converter operation will approach voltage mode (ramp compensation reduces the gain of the current loop). If too small an inductor is used, but the converter is still operating in CCM (near critical conduction mode), the internal ramp compensation may be inadequate to prevent subharmonic oscillation. To ensure good current mode gain and avoid subharmonic oscillation, it is recommended that the ripple current in the inductor fall in the range of 20% to 40% of the maximum average current. For example, if the maximum average input current is 1A, choose a ΔI_L between 0.2A and 0.4A, and a value ' χ ' between 0.2 and 0.4.

Boost Converter: Inductor Selection

Given an operating input voltage range, and having chosen the operating frequency and ripple current in the inductor, the inductor value can be determined using the following equation:

$$L = \frac{V_{IN(MIN)}}{\Delta I_L \cdot f} \cdot D_{MAX}$$

where:

$$\Delta I_L = \chi \cdot \frac{I_{O(MAX)}}{1 - D_{MAX}}$$

Remember that boost converters are **not** short-circuit protected. Under a shorted output condition, the inductor current is limited only by the input supply capability. For

applications requiring a step-up converter that is short-circuit protected, please refer to the applications section covering SEPIC converters.

The minimum required saturation current of the inductor can be expressed as a function of the duty cycle and the load current, as follows:

$$I_{L(SAT)} \geq \left(1 + \frac{\chi}{2}\right) \cdot \frac{I_{O(MAX)}}{1 - D_{MAX}}$$

The saturation current rating for the inductor should be checked at the minimum input voltage (which results in the highest inductor current) and maximum output current.

Boost Converter: Operating in Discontinuous Mode

Discontinuous mode operation occurs when the load current is low enough to allow the inductor current to run out during the off-time of the switch, as shown in Figure 9. Once the inductor current is near zero, the switch and diode capacitances resonate with the inductance to form damped ringing at 1MHz to 10MHz. If the off-time is long enough, the drain voltage will settle to the input voltage.

Depending on the input voltage and the residual energy in the inductor, this ringing can cause the drain of the power MOSFET to go below ground where it is clamped by the body diode. This ringing is not harmful to the IC and it has not been shown to contribute significantly to EMI. Any attempt to damp it with a snubber will degrade the efficiency.

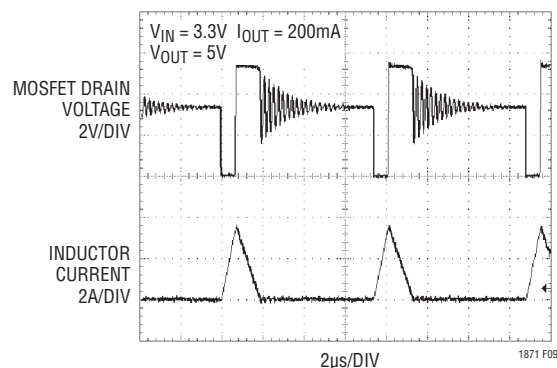

Figure 9. Discontinuous Mode Waveforms

APPLICATIONS INFORMATION

Boost Converter: Inductor Core Selection

Once the value for L is known, the type of inductor must be selected. High efficiency converters generally cannot afford the core loss found in low cost powdered iron cores, forcing the use of more expensive ferrite, molypermalloy or Kool M μ ® cores. Actual core loss is independent of core size for a fixed inductor value, but is very dependent on the inductance selected. As inductance increases, core losses go down. Unfortunately, increased inductance requires more turns of wire and therefore, copper losses will increase. Generally, there is a tradeoff between core losses and copper losses that needs to be balanced.

Ferrite designs have very low core losses and are preferred at high switching frequencies, so design goals can concentrate on copper losses and preventing saturation. Ferrite core material saturates “hard,” meaning that the inductance collapses rapidly when the peak design current is exceeded. This results in an abrupt increase in inductor ripple current and consequently, output voltage ripple. **Do not allow the core to saturate!**

Molypermalloy (from Magnetics, Inc.) is a very good, low cost core material for toroids, but is more expensive than ferrite. A reasonable compromise from the same manufacturer is Kool M μ .

Boost Converter: Power MOSFET Selection

The power MOSFET serves two purposes in the LTC1871: it represents the main switching element in the power path, and its $R_{DS(ON)}$ represents the current sensing element for the control loop. Important parameters for the power MOSFET include the drain-to-source breakdown voltage (BV_{DSS}), the threshold voltage ($V_{GS(TH)}$), the on-resistance ($R_{DS(ON)}$) versus gate-to-source voltage, the gate-to-source and gate-to-drain charges (Q_{GS} and Q_{GD} , respectively), the maximum drain current ($I_{D(MAX)}$) and the MOSFET's thermal resistances ($R_{TH(JC)}$ and $R_{TH(JA)}$).

The gate drive voltage is set by the 5.2V $INTV_{CC}$ low drop regulator. Consequently, logic-level threshold MOSFETs should be used in most LTC1871 applications. If low input voltage operation is expected (e.g., supplying power from a lithium-ion battery or a 3.3V logic supply), then sublogic-level threshold MOSFETs should be used.

Pay close attention to the BV_{DSS} specifications for the MOSFETs relative to the maximum actual switch voltage in the application. Many logic-level devices are limited to 30V or less, and the switch node can ring during the turn-off of the MOSFET due to layout parasitics. Check the switching waveforms of the MOSFET directly across the drain and source terminals using the actual PC board layout (not just on a lab breadboard!) for excessive ringing.

During the switch on-time, the control circuit limits the maximum voltage drop across the power MOSFET to about 150mV (at low duty cycle). The peak inductor current is therefore limited to $150\text{mV}/R_{DS(ON)}$. The relationship between the maximum load current, duty cycle and the $R_{DS(ON)}$ of the power MOSFET is:

$$R_{DS(ON)} \leq V_{SENSE(MAX)} \cdot \frac{1 - D_{MAX}}{\left(1 + \frac{\chi}{2}\right) \cdot I_{O(MAX)} \cdot \rho_T}$$

The $V_{SENSE(MAX)}$ term is typically 150mV at low duty cycle, and is reduced to about 100mV at a duty cycle of 92% due to slope compensation, as shown in Figure 10. The ρ_T term accounts for the temperature coefficient of the $R_{DS(ON)}$ of the MOSFET, which is typically 0.4%/°C. Figure 11 illustrates the variation of normalized $R_{DS(ON)}$ over temperature for a typical power MOSFET.

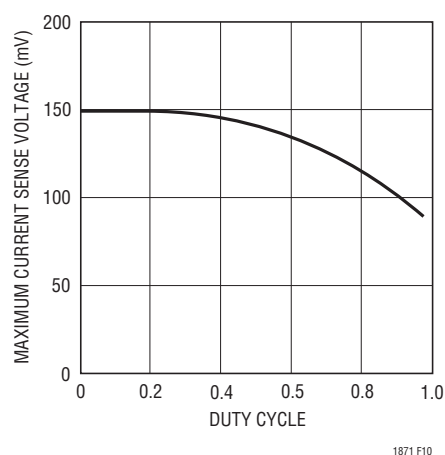

Figure 10. Maximum SENSE Threshold Voltage vs Duty Cycle

APPLICATIONS INFORMATION

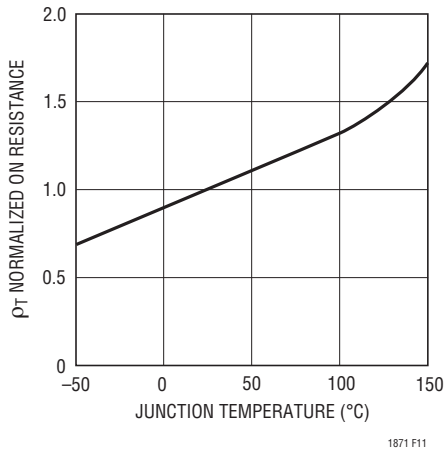

Figure 11. Normalized $R_{DS(ON)}$ vs Temperature

Another method of choosing which power MOSFET to use is to check what the maximum output current is for a given $R_{DS(ON)}$, since MOSFET on-resistances are available in discrete values.

$$I_{O(MAX)} = V_{SENSE(MAX)} \cdot \frac{1 - D_{MAX}}{\left(1 + \frac{\chi}{2}\right) \cdot R_{DS(ON)} \cdot \rho_T}$$

It is worth noting that the $1 - D_{MAX}$ relationship between $I_{O(MAX)}$ and $R_{DS(ON)}$ can cause boost converters with a wide input range to experience a dramatic range of maximum input and output current. This should be taken into consideration in applications where it is important to limit the maximum current drawn from the input supply.

Calculating Power MOSFET Switching and Conduction Losses and Junction Temperatures

In order to calculate the junction temperature of the power MOSFET, the power dissipated by the device must be known. This power dissipation is a function of the duty cycle, the load current and the junction temperature itself (due to the positive temperature coefficient of its $R_{DS(ON)}$). As a result, some iterative calculation is normally required to determine a reasonably accurate value. Since the controller is using the MOSFET as both a switching and a sensing element, care should be taken to ensure that the converter is capable of delivering the required load current over all operating conditions (line voltage and temperature), and for the worst-case specifications for $V_{SENSE(MAX)}$ and the $R_{DS(ON)}$ of the MOSFET listed in the manufacturer's data sheet.

The power dissipated by the MOSFET in a boost converter is:

$$P_{FET} = \left(\frac{I_{O(MAX)}}{1 - D_{MAX}}\right)^2 \cdot R_{DS(ON)} \cdot D_{MAX} \cdot \rho_T + k \cdot V_O^{1.85} \cdot \frac{I_{O(MAX)}}{(1 - D_{MAX})} \cdot C_{RSS} \cdot f$$

The first term in the equation above represents the I^2R losses in the device, and the second term, the switching losses. The constant, $k = 1.7$, is an empirical factor inversely related to the gate drive current and has the dimension of 1/current.

From a known power dissipated in the power MOSFET, its junction temperature can be obtained using the following formula:

$$T_J = T_A + P_{FET} \cdot R_{TH(JA)}$$

The $R_{TH(JA)}$ to be used in this equation normally includes the $R_{TH(JC)}$ for the device plus the thermal resistance from the case to the ambient temperature ($R_{TH(CA)}$). This value of T_J can then be compared to the original, assumed value used in the iterative calculation process.

Boost Converter: Output Diode Selection

To maximize efficiency, a fast switching diode with low forward drop and low reverse leakage is desired. The output diode in a boost converter conducts current during the switch off-time. The peak reverse voltage that the diode must withstand is equal to the regulator output voltage. The average forward current in normal operation is equal to the output current, and the peak current is equal to the peak inductor current.

$$I_{D(PEAK)} = I_{L(PEAK)} = \left(1 + \frac{\chi}{2}\right) \cdot \frac{I_{O(MAX)}}{1 - D_{MAX}}$$

The power dissipated by the diode is:

$$P_D = I_{O(MAX)} \cdot V_D$$

and the diode junction temperature is:

$$T_J = T_A + P_D \cdot R_{TH(JA)}$$

The $R_{TH(JA)}$ to be used in this equation normally includes the $R_{TH(JC)}$ for the device plus the thermal resistance from the board to the ambient temperature in the enclosure.

APPLICATIONS INFORMATION

Remember to keep the diode lead lengths short and to observe proper switch-node layout (see Board Layout Checklist) to avoid excessive ringing and increased dissipation.

Boost Converter: Output Capacitor Selection

Contributions of ESR (equivalent series resistance), ESL (equivalent series inductance) and the bulk capacitance must be considered when choosing the correct component for a given output ripple voltage. The effects of these three parameters (ESR, ESL and bulk C) on the output voltage ripple waveform are illustrated in Figure 12e for a typical boost converter.

The choice of component(s) begins with the maximum acceptable ripple voltage (expressed as a percentage of the output voltage), and how this ripple should be divided between the ESR step and the charging/discharging ΔV . For the purpose of simplicity we will choose 2% for the maximum output ripple, to be divided equally between the ESR step and the charging/discharging ΔV . This percentage ripple will change, depending on the requirements of the application, and the equations provided below can easily be modified.

For a 1% contribution to the total ripple voltage, the ESR of the output capacitor can be determined using the following equation:

$$ESR_{COUT} \leq \frac{0.01 \cdot V_O}{I_{IN(PEAK)}}$$

where:

$$I_{IN(PEAK)} = \left(1 + \frac{\chi}{2}\right) \cdot \frac{I_{O(MAX)}}{1 - D_{MAX}}$$

For the bulk C component, which also contributes 1% to the total ripple:

$$C_{OUT} \geq \frac{I_{O(MAX)}}{0.01 \cdot V_O \cdot f}$$

For many designs it is possible to choose a single capacitor type that satisfies both the ESR and bulk C requirements for the design. In certain demanding applications, however, the ripple voltage can be improved significantly by con-

necting two or more types of capacitors in parallel. For example, using a low ESR ceramic capacitor can minimize the ESR step, while an electrolytic capacitor can be used to supply the required bulk C.

Once the output capacitor ESR and bulk capacitance have been determined, the overall ripple voltage waveform should be verified on a dedicated PC board (see Board Layout section for more information on component placement). Lab breadboards generally suffer from excessive series inductance (due to inter-component wiring), and these parasitics can make the switching waveforms look significantly worse than they would be on a properly designed PC board.

The output capacitor in a boost regulator experiences high RMS ripple currents, as shown in Figure 12. The RMS output capacitor ripple current is:

$$I_{RMS(COUT)} \approx I_{O(MAX)} \cdot \sqrt{\frac{V_O - V_{IN(MIN)}}{V_{IN(MIN)}}}$$

Note that the ripple current ratings from capacitor manufacturers are often based on only 2000 hours of life. This makes it advisable to further derate the capacitor or to choose a capacitor rated at a higher temperature than required. Several capacitors may also be placed in parallel to meet size or height requirements in the design.

Manufacturers such as Nichicon, United Chemicon and Sanyo should be considered for high performance through-hole capacitors. The OS-CON semiconductor dielectric capacitor available from Sanyo has the lowest product of ESR and size of any aluminum electrolytic, at a somewhat higher price.

In surface mount applications, multiple capacitors may have to be placed in parallel in order to meet the ESR or RMS current handling requirements of the application. Aluminum electrolytic and dry tantalum capacitors are both available in surface mount packages. In the case of tantalum, it is critical that the capacitors have been surge tested for use in switching power supplies. An excellent choice is AVX TPS series of surface mount tantalum. Also, ceramic capacitors are now available with extremely low ESR, ESL and high ripple current ratings.

APPLICATIONS INFORMATION

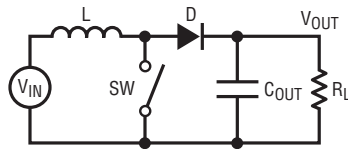

12a. Circuit Diagram

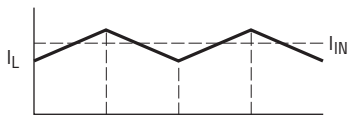

12b. Inductor and Input Currents

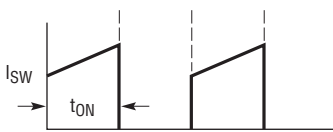

12c. Switch Current

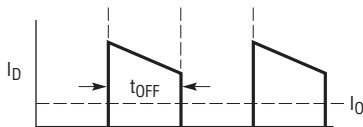

12d. Diode and Output Currents

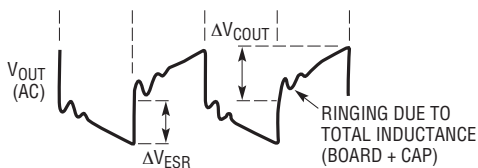

12e. Output Voltage Ripple Waveform

Figure 12. Switching Waveforms for a Boost Converter

Boost Converter: Input Capacitor Selection

The input capacitor of a boost converter is less critical than the output capacitor, due to the fact that the inductor is in series with the input and the input current waveform is continuous (see Figure 12b). The input voltage source impedance determines the size of the input capacitor, which is typically in the range of 10 μ F to 100 μ F. A low ESR capacitor is recommended, although it is not as critical as for the output capacitor.

The RMS input capacitor ripple current for a boost converter is:

$$I_{\text{RMS(CIN)}} = 0.3 \cdot \frac{V_{\text{IN(MIN)}}}{L \cdot f} \cdot D_{\text{MAX}}$$

Please note that the input capacitor can see a very high surge current when a battery is suddenly connected to the input of the converter and solid tantalum capacitors can fail catastrophically under these conditions. **Be sure to specify surge-tested capacitors!**

Burst Mode Operation and Considerations

The choice of MOSFET $R_{\text{DS(ON)}}$ and inductor value also determines the load current at which the LTC1871 enters Burst Mode operation. When bursting, the controller clamps the peak inductor current to approximately:

$$I_{\text{BURST(PEAK)}} = \frac{30\text{mV}}{R_{\text{DS(ON)}}}$$

which represents about 20% of the maximum 150mV SENSE pin voltage. The corresponding average current depends upon the amount of ripple current. Lower inductor values (higher ΔI_L) will reduce the load current at which Burst Mode operations begins, since it is the peak current that is being clamped.

The output voltage ripple can increase during Burst Mode operation if ΔI_L is substantially less than I_{BURST} . This can occur if the input voltage is very low or if a very large inductor is chosen. At high duty cycles, a skipped cycle causes the inductor current to quickly decay to zero. However, because ΔI_L is small, it takes multiple cycles for the current to ramp back up to $I_{\text{BURST(PEAK)}}$. During this inductor charging interval, the output capacitor must supply the load current and a significant droop in the output voltage can occur. Generally, it is a good idea to choose a value of inductor ΔI_L between 25% and 40% of $I_{\text{IN(MAX)}}$. The alternative is to either increase the value of the output capacitor or disable Burst Mode operation using the MODE/SYNC pin.

Burst Mode operation can be defeated by connecting the MODE/SYNC pin to a high logic-level voltage (either with a control input or by connecting this pin to INTV_{CC}). In this mode, the burst clamp is removed, and the chip can operate at constant frequency from continuous conduction mode (CCM) at full load, down into deep discontinuous conduction mode (DCM) at light load. Prior to skipping pulses at very light load (i.e., <5% of full load), the controller will operate with a minimum switch on-time in DCM.

APPLICATIONS INFORMATION

Table 1. Recommended Component Manufacturers

| VENDOR | COMPONENTS | TELEPHONE | WEB ADDRESS |
|-------------------------|-------------------------|----------------|--------------------------|
| AVX | Capacitors | (207) 282-5111 | avxcorp.com |
| BH Electronics | Inductors, Transformers | (952) 894-9590 | bhelectronics.com |
| Coilcraft | Inductors | (847) 639-6400 | coilcraft.com |
| Coiltronics | Inductors | (407) 241-7876 | coiltronics.com |
| Diodes, Inc | Diodes | (805) 446-4800 | diodes.com |
| Fairchild | MOSFETs | (408) 822-2126 | fairchildsemi.com |
| General Semiconductor | Diodes | (516) 847-3000 | generalsemiconductor.com |
| International Rectifier | MOSFETs, Diodes | (310) 322-3331 | irf.com |
| IRC | Sense Resistors | (361) 992-7900 | ircct.com |
| Kemet | Tantalum Capacitors | (408) 986-0424 | kemet.com |
| Magnetics Inc | Toroid Cores | (800) 245-3984 | mag-inc.com |
| Microsemi | Diodes | (617) 926-0404 | microsemi.com |
| Murata-Erie | Inductors, Capacitors | (770) 436-1300 | murata.co.jp |
| Nichicon | Capacitors | (847) 843-7500 | nichicon.com |
| On Semiconductor | Diodes | (602) 244-6600 | onsemi.com |
| Panasonic | Capacitors | (714) 373-7334 | panasonic.com |
| Sanyo | Capacitors | (619) 661-6835 | sanyo.co.jp |
| Sumida | Inductors | (847) 956-0667 | sumida.com |
| Taiyo Yuden | Capacitors | (408) 573-4150 | t-yuden.com |
| TDK | Capacitors, Inductors | (562) 596-1212 | component.tdk.com |
| Thermalloy | Heat Sinks | (972) 243-4321 | aavidthermalloy.com |
| Tokin | Capacitors | (408) 432-8020 | nec-tokinamerica.com |
| Toko | Inductors | (847) 699-3430 | tokoam.com |
| United Chemicon | Capacitors | (847) 696-2000 | chemi-com.com |
| Vishay/Dale | Resistors | (605) 665-9301 | vishay.com |
| Vishay/Siliconix | MOSFETs | (800) 554-5565 | vishay.com |
| Vishay/Sprague | Capacitors | (207) 324-4140 | vishay.com |
| Zetex | Small-Signal Discretets | (631) 543-7100 | zetex.com |

Pulse skipping prevents a loss of control of the output at very light loads and reduces output voltage ripple.

Efficiency Considerations: How Much Does V_{DS} Sensing Help?

The efficiency of a switching regulator is equal to the output power divided by the input power ($\times 100\%$). Percent efficiency can be expressed as:

$$\% \text{ Efficiency} = 100\% - (L1 + L2 + L3 + \dots),$$

where L1, L2, etc. are the individual loss components as a percentage of the input power. It is often useful to analyze individual losses to determine what is limiting the efficiency

and which change would produce the most improvement. Although all dissipative elements in the circuit produce losses, four main sources usually account for the majority of the losses in LTC1871 application circuits:

1. The supply current into V_{IN} . The V_{IN} current is the sum of the DC supply current I_Q (given in the Electrical Characteristics) and the MOSFET driver and control currents. The DC supply current into the V_{IN} pin is typically about $550\mu\text{A}$ and represents a small power loss (much less than 1%) that increases with V_{IN} . The driver current results from switching the gate capacitance of the power MOSFET; this current is typically much larger than the DC current. Each time the MOSFET is switched on and

APPLICATIONS INFORMATION

then off, a packet of gate charge Q_G is transferred from $INTV_{CC}$ to ground. The resulting dQ/dt is a current that must be supplied to the $INTV_{CC}$ capacitor through the V_{IN} pin by an external supply. If the IC is operating in CCM:

$$I_{Q(TOT)} \approx I_Q = f \cdot Q_G$$

$$P_{IC} = V_{IN} \cdot (I_Q + f \cdot Q_G)$$

2. Power MOSFET switching and conduction losses. The technique of using the voltage drop across the power MOSFET to close the current feedback loop was chosen because of the increased efficiency that results from not having a sense resistor. The losses in the power MOSFET are equal to:

$$P_{FET} = \left(\frac{I_{O(MAX)}}{1-D_{MAX}} \right)^2 \cdot R_{DS(ON)} \cdot D_{MAX} \cdot \rho_T \\ + k \cdot V_0^{1.85} \cdot \frac{I_{O(MAX)}}{(1-D_{MAX})} \cdot C_{RSS} \cdot f$$

The I^2R power savings that result from not having a discrete sense resistor can be calculated almost by inspection.

$$P_{R(SENSE)} = \left(\frac{I_{O(MAX)}}{1-D_{MAX}} \right)^2 \cdot R_{SENSE} \cdot D_{MAX}$$

To understand the magnitude of the improvement with this V_{DS} sensing technique, consider the 3.3V input, 5V output power supply shown in Figure 1. The maximum load current is 7A (10A peak) and the duty cycle is 39%. Assuming a ripple current of 40%, the peak inductor current is 13.8A and the average is 11.5A. With a maximum sense voltage of about 140mV, the sense resistor value would be 10m Ω , and the power dissipated in this resistor would be 514mW at maximum output current. Assuming an efficiency of 90%, this sense resistor power dissipation represents 1.3% of the overall input power. In other words, for this application, the use of V_{DS} sensing would increase the efficiency by approximately 1.3%.

For more details regarding the various terms in these equations, please refer to the section Boost Converter: Power MOSFET Selection.

3. The losses in the inductor are simply the DC input current squared times the winding resistance. Expressing this loss as a function of the output current yields:

$$P_{R(WINDING)} = \left(\frac{I_{O(MAX)}}{1-D_{MAX}} \right)^2 \cdot R_W$$

4. Losses in the boost diode. The power dissipation in the boost diode is:

$$P_{DIODE} = I_{O(MAX)} \cdot V_D$$

The boost diode can be a major source of power loss in a boost converter. For the 3.3V input, 5V output at 7A example given above, a Schottky diode with a 0.4V forward voltage would dissipate 2.8W, which represents 7% of the input power. Diode losses can become significant at low output voltages where the forward voltage is a significant percentage of the output voltage.

5. Other losses, including C_{IN} and C_O ESR dissipation and inductor core losses, generally account for less than 2% of the total additional loss.

Checking Transient Response

The regulator loop response can be verified by looking at the load transient response. Switching regulators generally take several cycles to respond to an instantaneous step in resistive load current. When the load step occurs, V_O immediately shifts by an amount equal to $(\Delta I_{LOAD})/ESR$, and then C_O begins to charge or discharge (depending on the direction of the load step) as shown in Figure 13. The regulator feedback loop acts on the resulting error amp output signal to return V_O to its steady-state value. During this recovery time, V_O can be monitored for overshoot or ringing that would indicate a stability problem.

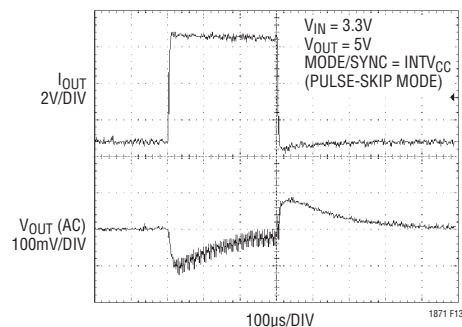

Figure 13. Load Transient Response for a 3.3V Input, 5V Output Boost Converter Application, 0.7A to 7A Step

1871fe

APPLICATIONS INFORMATION

A second, more severe transient can occur when connecting loads with large ($> 1\mu\text{F}$) supply bypass capacitors. The discharged bypass capacitors are effectively put in parallel with C_0 , causing a nearly instantaneous drop in V_0 . No regulator can deliver enough current to prevent this problem if the load switch resistance is low and it is driven quickly. The only solution is to limit the rise time of the switch drive in order to limit the inrush current di/dt to the load.

Boost Converter Design Example

The design example given here will be for the circuit shown in Figure 1. The input voltage is 3.3V, and the output is 5V at a maximum load current of 7A (10A peak).

1. The duty cycle is:

$$D = \left(\frac{V_0 + V_D - V_{IN}}{V_0 + V_D} \right) = \frac{5 + 0.4 - 3.3}{5 + 0.4} = 38.9\%$$

2. Pulse-skip operation is chosen so the MODE/SYNC pin is shorted to INTV_{CC}.
3. The operating frequency is chosen to be 300kHz to reduce the size of the inductor. From Figure 5, the resistor from the FREQ pin to ground is 80k.
4. An inductor ripple current of 40% of the maximum load current is chosen, so the peak input current (which is also the minimum saturation current) is:

$$I_{IN(PEAK)} = \left(1 + \frac{\chi}{2} \right) \cdot \frac{I_{O(MAX)}}{1 - D_{MAX}} = 1.2 \cdot \frac{7}{1 - 0.39} = 13.8\text{A}$$

The inductor ripple current is:

$$\Delta I_L = \chi \cdot \frac{I_{O(MAX)}}{1 - D_{MAX}} = 0.4 \cdot \frac{7}{1 - 0.39} = 4.6\text{A}$$

And so the inductor value is:

$$L = \frac{V_{IN(MIN)}}{\Delta I_L \cdot f} \cdot D_{MAX} = \frac{3.3\text{V}}{4.6\text{A} \cdot 300\text{kHz}} \cdot 0.39 = 0.93\mu\text{H}$$

The component chosen is a 1 μH inductor made by Sumida (part number CEP125-H 1ROMH) which has a saturation current of greater than 20A.

5. With the input voltage to the IC bootstrapped to the output of the power supply (5V), a logic-level MOSFET

can be used. Because the duty cycle is 39%, the maximum SENSE pin threshold voltage is reduced from its low duty cycle typical value of 150mV to approximately 140mV. Assuming a MOSFET junction temperature of 125°C, the room temperature MOSFET $R_{DS(ON)}$ should be less than:

$$R_{DS(ON)} \leq V_{SENSE(MAX)} \cdot \frac{1 - D_{MAX}}{\left(1 + \frac{\chi}{2} \right) \cdot I_{O(MAX)} \cdot P_T}$$

$$= 0.140\text{V} \cdot \frac{1 - 0.39}{\left(1 + \frac{0.4}{2} \right) \cdot 7\text{A} \cdot 1.5} = 6.8\text{m}\Omega$$

The MOSFET used was the Fairchild FDS7760A, which has a maximum $R_{DS(ON)}$ of 8m Ω at 4.5V V_{GS} , a BV_{DSS} of greater than 30V, and a gate charge of 37nC at 5V V_{GS} .

6. The diode for this design must handle a maximum DC output current of 10A and be rated for a minimum reverse voltage of V_{OUT} , or 5V. A 25A, 15V diode from On Semiconductor (MBRB2515L) was chosen for its high power dissipation capability.
7. The output capacitor usually consists of a high valued bulk C connected in parallel with a lower valued, low ESR ceramic. Based on a maximum output ripple voltage of 1%, or 50mV, the bulk C needs to be greater than:

$$C_{OUT} \geq \frac{I_{OUT(MAX)}}{0.01 \cdot V_{OUT} \cdot f}$$

$$\frac{7\text{A}}{0.01 \cdot 5\text{V} \cdot 300\text{kHz}} = 466\mu\text{F}$$

The RMS ripple current rating for this capacitor needs to exceed:

$$I_{RMS(COUT)} \geq I_{O(MAX)} \cdot \sqrt{\frac{V_0 - V_{IN(MIN)}}{V_{IN(MIN)}}}$$

$$7\text{A} \cdot \sqrt{\frac{5\text{V} - 3.3\text{V}}{3.3\text{V}}} = 5\text{A}$$

To satisfy this high RMS current demand, four 150 μF Panasonic capacitors (EEFUEOJ151R) are required. In parallel with these bulk capacitors, two 22 μF , low ESR (X5R) Taiyo Yuden ceramic capacitors

APPLICATIONS INFORMATION

(JMK325BJ226MM) are added for HF noise reduction. Check the output ripple with a single oscilloscope probe connected directly across the output capacitor terminals, where the HF switching currents flow.

8. The choice of an input capacitor for a boost converter depends on the impedance of the source supply and the amount of input ripple the converter will safely tolerate. For this particular design and lab setup a 100 μ F Sanyo Poscap (6TPC 100M), in parallel with two 22 μ F Taiyo Yuden ceramic capacitors (JMK325BJ226MM) is required (the input and return lead lengths are kept to a few inches, but the peak input current is close to 20A!). As with the output node, check the input ripple with a single oscilloscope probe connected across the input capacitor terminals.

PC Board Layout Checklist

1. In order to minimize switching noise and improve output load regulation, the GND pin of the LTC1871 should be connected directly to 1) the negative terminal of the INTV_{CC} decoupling capacitor, 2) the negative terminal of the output decoupling capacitors, 3) the source of the power MOSFET or the bottom terminal of the sense resistor, 4) the negative terminal of the input capacitor and 5) at least one via to the ground plane immediately adjacent to Pin 6. The ground trace on the top layer of the PC board should be as wide and short as possible to minimize series resistance and inductance.
2. Beware of ground loops in multiple layer PC boards. Try to maintain one central ground node on the board and use the input capacitor to avoid excess input ripple for high output current power supplies. If the ground plane is to be used for high DC currents, choose a path away from the small-signal components.
3. Place the C_{VCC} capacitor immediately adjacent to the INTV_{CC} and GND pins on the IC package. This capacitor carries high di/dt MOSFET gate drive currents. A low ESR and ESL 4.7 μ F ceramic capacitor works well here.
4. The high di/dt loop from the bottom terminal of the output capacitor, through the power MOSFET, through the boost diode and back through the output capacitors should be kept as tight as possible to reduce inductive ringing. Excess inductance can cause increased stress on the power MOSFET and increase HF noise on the output. If low ESR ceramic capacitors are used on the output to reduce output noise, place these capacitors close to the boost diode in order to keep the series inductance to a minimum.
5. Check the stress on the power MOSFET by measuring its drain-to-source voltage directly across the device terminals (reference the ground of a single scope probe directly to the source pad on the PC board). Beware of inductive ringing which can exceed the maximum specified voltage rating of the MOSFET. If this ringing cannot be avoided and exceeds the maximum rating of the device, either choose a higher voltage device or specify an avalanche-rated power MOSFET. Not all MOSFETs are created equal (some are more equal than others).
6. Place the small-signal components away from high frequency switching nodes. In the layout shown in Figure 14, all of the small-signal components have been placed on one side of the IC and all of the power components have been placed on the other. This also allows the use of a pseudo-Kelvin connection for the signal ground, where high di/dt gate driver currents flow out of the IC ground pin in one direction (to the bottom plate of the INTV_{CC} decoupling capacitor) and small-signal currents flow in the other direction.
7. If a sense resistor is used in the source of the power MOSFET, minimize the capacitance between the SENSE pin trace and any high frequency switching nodes. The LTC1871 contains an internal leading edge blanking time of approximately 180ns, which should be adequate for most applications.
8. For optimum load regulation and true remote sensing, the top of the output resistor divider should connect independently to the top of the output capacitor (Kelvin connection), staying away from any high dV/dt traces. Place the divider resistors near the LTC1871 in order to keep the high impedance FB node short.
9. For applications with multiple switching power converters connected to the same input supply, make sure

APPLICATIONS INFORMATION

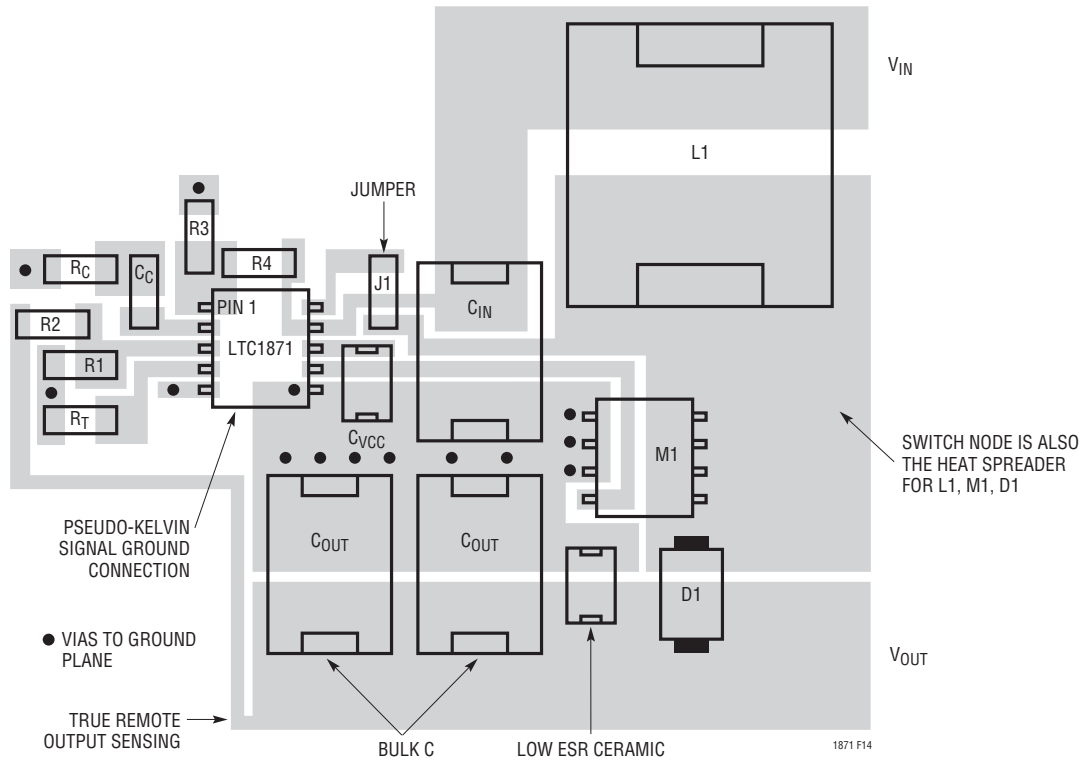

Figure 14. LTC1871 Boost Converter Suggested Layout

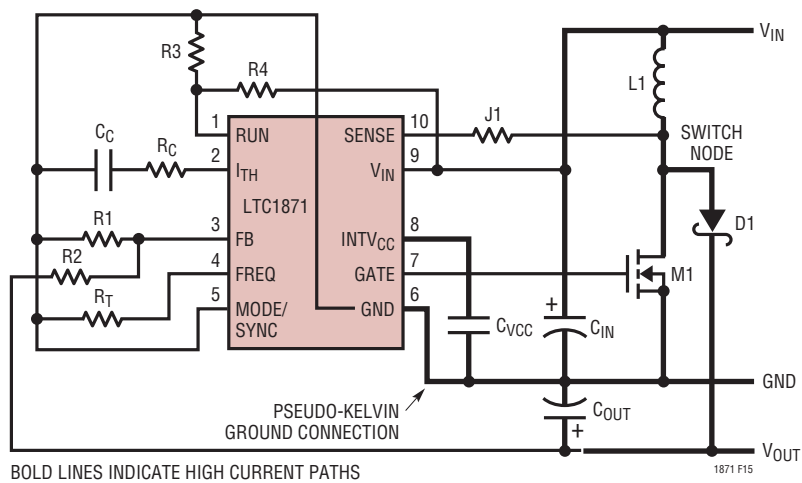

Figure 15. LTC1871 Boost Converter Layout Diagram

APPLICATIONS INFORMATION

that the input filter capacitor for the LTC1871 is not shared with other converters. AC input current from another converter could cause substantial input voltage ripple, and this could interfere with the operation of the LTC1871. A few inches of PC trace or wire ($L \approx 100\text{nH}$) between the C_{IN} of the LTC1871 and the actual source V_{IN} should be sufficient to prevent current sharing problems.

SEPIC Converter Applications

The LTC1871 is also well suited to SEPIC (single-ended primary inductance converter) converter applications. The SEPIC converter shown in Figure 16 uses two inductors. The advantage of the SEPIC converter is the input voltage may be higher or lower than the output voltage, and the output is short-circuit protected.

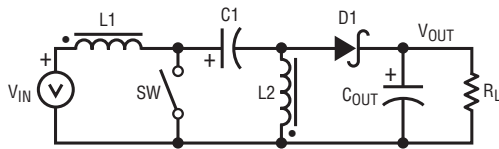

16a. SEPIC Topology

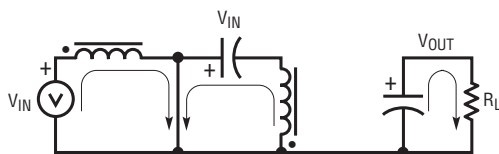

16b. Current Flow During Switch On-Time

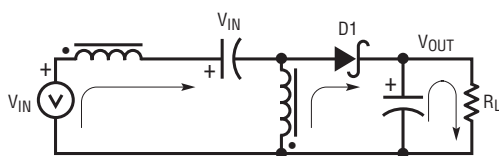

16c. Current Flow During Switch Off-Time

Figures 16. SEPIC Topology and Current Flow

The first inductor, $L1$, together with the main switch, resembles a boost converter. The second inductor, $L2$, together with the output diode $D1$, resembles a flyback or buck-boost converter. The two inductors $L1$ and $L2$ can be independent but can also be wound on the same core since identical voltages are applied to $L1$ and $L2$ throughout the switching cycle. By making $L1 = L2$ and winding them on the same core the input ripple is reduced along with cost

and size. All of the SEPIC applications information that follows assumes $L1 = L2 = L$.

SEPIC Converter: Duty Cycle Considerations

For a SEPIC converter operating in a continuous conduction mode (CCM), the duty cycle of the main switch is:

$$D = \left(\frac{V_O + V_D}{V_{IN} + V_O + V_D} \right)$$

where V_D is the forward voltage of the diode. For converters where the input voltage is close to the output voltage the duty cycle is near 50%.

The maximum output voltage for a SEPIC converter is:

$$V_{O(\text{MAX})} = (V_{IN} + V_D) \frac{D_{\text{MAX}}}{1 - D_{\text{MAX}}} - V_D \frac{1}{1 - D_{\text{MAX}}}$$

The maximum duty cycle of the LTC1871 is typically 92%.

SEPIC Converter: The Peak and Average Input Currents

The control circuit in the LTC1871 is measuring the input current (either using the $R_{DS(\text{ON})}$ of the power MOSFET or by means of a sense resistor in the MOSFET source), so the output current needs to be reflected back to the input in order to dimension the power MOSFET properly. Based on the fact that, ideally, the output power is equal to the input power, the maximum input current for a SEPIC converter is:

$$I_{IN(\text{MAX})} = I_{O(\text{MAX})} \cdot \frac{D_{\text{MAX}}}{1 - D_{\text{MAX}}}$$

The peak input current is:

$$I_{IN(\text{PEAK})} = \left(1 + \frac{\chi}{2} \right) \cdot I_{O(\text{MAX})} \cdot \frac{D_{\text{MAX}}}{1 - D_{\text{MAX}}}$$

The maximum duty cycle, D_{MAX} , should be calculated at minimum V_{IN} .

The constant ' χ ' represents the fraction of ripple current in the inductor relative to its maximum value. For example, if 30% ripple current is chosen, then $\chi = 0.30$ and the peak current is 15% greater than the average.

APPLICATIONS INFORMATION

It is worth noting here that SEPIC converters that operate at high duty cycles (i.e., that develop a high output voltage from a low input voltage) can have very high input currents, relative to the output current. Be sure to check that the maximum load current will not overload the input supply.

SEPIC Converter: Inductor Selection

For most SEPIC applications the equal inductor values will fall in the range of 10 μ H to 100 μ H. Higher values will reduce the input ripple voltage and reduce the core loss. Lower inductor values are chosen to reduce physical size and improve transient response.

Like the boost converter, the input current of the SEPIC converter is calculated at full load current and minimum input voltage. The peak inductor current can be significantly higher than the output current, especially with smaller inductors and lighter loads. The following formulas assume CCM operation and calculate the maximum peak inductor currents at minimum V_{IN} :

$$I_{L1(PEAK)} = \left(1 + \frac{\chi}{2}\right) \cdot I_{O(MAX)} \cdot \frac{V_O + V_D}{V_{IN(MIN)}}$$

$$I_{L2(PEAK)} = \left(1 + \frac{\chi}{2}\right) \cdot I_{O(MAX)} \cdot \frac{V_{IN(MIN)} + V_D}{V_{IN(MIN)}}$$

The ripple current in the inductor is typically 20% to 40% (i.e., a range of ' χ ' from 0.20 to 0.40) of the maximum average input current occurring at $V_{IN(MIN)}$ and $I_{O(MAX)}$ and $\Delta I_{L1} = \Delta I_{L2}$. Expressing this ripple current as a function of the output current results in the following equations for calculating the inductor value:

$$L = \frac{V_{IN(MIN)}}{\Delta I_L \cdot f} \cdot D_{MAX}$$

where:

$$\Delta I_L = \chi \cdot I_{O(MAX)} \cdot \frac{D_{MAX}}{1 - D_{MAX}}$$

By making $L1 = L2$ and winding them on the same core, the value of inductance in the equation above is replaced by 2L due to mutual inductance. Doing this maintains the same ripple current and energy storage in the inductors. For

example, a Coiltronix CTX10-4 is a 10 μ H inductor with two windings. With the windings in parallel, 10 μ H inductance is obtained with a current rating of 4A (the number of turns hasn't changed, but the wire diameter has doubled). Splitting the two windings creates two 10 μ H inductors with a current rating of 2A each. Therefore, substituting 2L yields the following equation for coupled inductors:

$$L1=L2 = \frac{V_{IN(MIN)}}{2 \cdot \Delta I_L \cdot f} \cdot D_{MAX}$$

Specify the maximum inductor current to safely handle $I_{L(PK)}$ specified in the equation above. The saturation current rating for the inductor should be checked at the minimum input voltage (which results in the highest inductor current) and maximum output current.

SEPIC Converter: Power MOSFET Selection

The power MOSFET serves two purposes in the LTC1871: it represents the main switching element in the power path, and its $R_{DS(ON)}$ represents the current sensing element for the control loop. Important parameters for the power MOSFET include the drain-to-source breakdown voltage (BV_{DSS}), the threshold voltage ($V_{GS(TH)}$), the on-resistance ($R_{DS(ON)}$) versus gate-to-source voltage, the gate-to-source and gate-to-drain charges (Q_{GS} and Q_{GD} , respectively), the maximum drain current ($I_{D(MAX)}$) and the MOSFET's thermal resistances ($R_{TH(JC)}$ and $R_{TH(JA)}$).

The gate drive voltage is set by the 5.2V $INTV_{CC}$ low dropout regulator. Consequently, logic-level threshold MOSFETs should be used in most LTC1871 applications. If low input voltage operation is expected (e.g., supplying power from a lithium-ion battery), then sublogic-level threshold MOSFETs should be used.

The maximum voltage that the MOSFET switch must sustain during the off-time in a SEPIC converter is equal to the sum of the input and output voltages ($V_O + V_{IN}$). As a result, careful attention must be paid to the BV_{DSS} specifications for the MOSFETs relative to the maximum actual switch voltage in the application. Many logic-level devices are limited to 30V or less. Check the switching waveforms directly across the drain and source terminals of the power MOSFET to ensure the V_{DS} remains below the maximum rating for the device.

APPLICATIONS INFORMATION

During the MOSFET's on-time, the control circuit limits the maximum voltage drop across the power MOSFET to about 150mV (at low duty cycle). The peak inductor current is therefore limited to $150\text{mV}/R_{\text{DS(ON)}}$. The relationship between the maximum load current, duty cycle and the $R_{\text{DS(ON)}}$ of the power MOSFET is:

$$R_{\text{DS(ON)}} \leq \frac{V_{\text{SENSE(MAX)}}}{I_{\text{O(MAX)}}} \cdot \frac{1}{\left(1 + \frac{\chi}{2}\right) \cdot \rho_T} \cdot \frac{1}{\left(\frac{V_{\text{O}} + V_{\text{D}}}{V_{\text{IN(MIN)}}}\right) + 1}$$

The $V_{\text{SENSE(MAX)}}$ term is typically 150mV at low duty cycle and is reduced to about 100mV at a duty cycle of 92% due to slope compensation, as shown in Figure 8. The constant ' χ ' in the denominator represents the ripple current in the inductors relative to their maximum current. For example, if 30% ripple current is chosen, then $\chi = 0.30$. The ρ_T term accounts for the temperature coefficient of the $R_{\text{DS(ON)}}$ of the MOSFET, which is typically 0.4%/°C. Figure 9 illustrates the variation of normalized $R_{\text{DS(ON)}}$ over temperature for a typical power MOSFET.

Another method of choosing which power MOSFET to use is to check what the maximum output current is for a given $R_{\text{DS(ON)}}$ since MOSFET on-resistances are available in discrete values.

$$I_{\text{O(MAX)}} \leq \frac{V_{\text{SENSE(MAX)}}}{R_{\text{DS(ON)}}} \cdot \frac{1}{\left(1 + \frac{\chi}{2}\right) \cdot \rho_T} \cdot \frac{1}{\left(\frac{V_{\text{O}} + V_{\text{D}}}{V_{\text{IN(MIN)}}}\right) + 1}$$

Calculating Power MOSFET Switching and Conduction Losses and Junction Temperatures

In order to calculate the junction temperature of the power MOSFET, the power dissipated by the device must be known. This power dissipation is a function of the duty cycle, the load current and the junction temperature itself. As a result, some iterative calculation is normally required to determine a reasonably accurate value. Since the controller is using the MOSFET as both a switching and a sensing element, care should be taken to ensure that the converter is capable of delivering the required load current over all operating conditions (load, line and temperature) and for the worst-case specifications for $V_{\text{SENSE(MAX)}}$ and the $R_{\text{DS(ON)}}$ of the MOSFET listed in the manufacturer's data sheet.

The power dissipated by the MOSFET in a SEPIC converter is:

$$P_{\text{FET}} = \left(I_{\text{O(MAX)}} \cdot \frac{D_{\text{MAX}}}{1 - D_{\text{MAX}}} \right)^2 \cdot R_{\text{DS(ON)}} \cdot D_{\text{MAX}} \cdot \rho_T + k \cdot \left(V_{\text{IN(MIN)}} + V_{\text{O}} \right)^{1.85} \cdot I_{\text{O(MAX)}} \cdot \frac{D_{\text{MAX}}}{1 - D_{\text{MAX}}} \cdot C_{\text{RSS}} \cdot f$$

The first term in the equation above represents the I^2R losses in the device and the second term, the switching losses. The constant $k = 1.7$ is an empirical factor inversely related to the gate drive current and has the dimension of 1/current.

From a known power dissipated in the power MOSFET, its junction temperature can be obtained using the following formula:

$$T_{\text{J}} = T_{\text{A}} + P_{\text{FET}} \cdot R_{\text{TH(JA)}}$$

The $R_{\text{TH(JA)}}$ to be used in this equation normally includes the $R_{\text{TH(JC)}}$ for the device plus the thermal resistance from the board to the ambient temperature in the enclosure. This value of T_{J} can then be used to check the original assumption for the junction temperature in the iterative calculation process.

SEPIC Converter: Output Diode Selection

To maximize efficiency, a fast-switching diode with low forward drop and low reverse leakage is desired. The output diode in a SEPIC converter conducts current during the switch off-time. The peak reverse voltage that the diode must withstand is equal to $V_{\text{IN(MAX)}} + V_{\text{O}}$. The average forward current in normal operation is equal to the output current, and the peak current is equal to:

$$I_{\text{D(PEAK)}} = \left(1 + \frac{\chi}{2} \right) \cdot I_{\text{O(MAX)}} \cdot \left(\frac{V_{\text{O}} + V_{\text{D}}}{V_{\text{IN(MIN)}}} + 1 \right)$$

The power dissipated by the diode is:

$$P_{\text{D}} = I_{\text{O(MAX)}} \cdot V_{\text{D}}$$

and the diode junction temperature is:

$$T_{\text{J}} = T_{\text{A}} + P_{\text{D}} \cdot R_{\text{TH(JA)}}$$

The $R_{\text{TH(JA)}}$ to be used in this equation normally includes the $R_{\text{TH(JC)}}$ for the device plus the thermal resistance from the board to the ambient temperature in the enclosure.

APPLICATIONS INFORMATION

SEPIC Converter: Output Capacitor Selection

Because of the improved performance of today's electrolytic, tantalum and ceramic capacitors, engineers need to consider the contributions of ESR (equivalent series resistance), ESL (equivalent series inductance) and the bulk capacitance when choosing the correct component for a given output ripple voltage. The effects of these three parameters (ESR, ESL, and bulk C) on the output voltage ripple waveform are illustrated in Figure 17 for a typical coupled-inductor SEPIC converter.

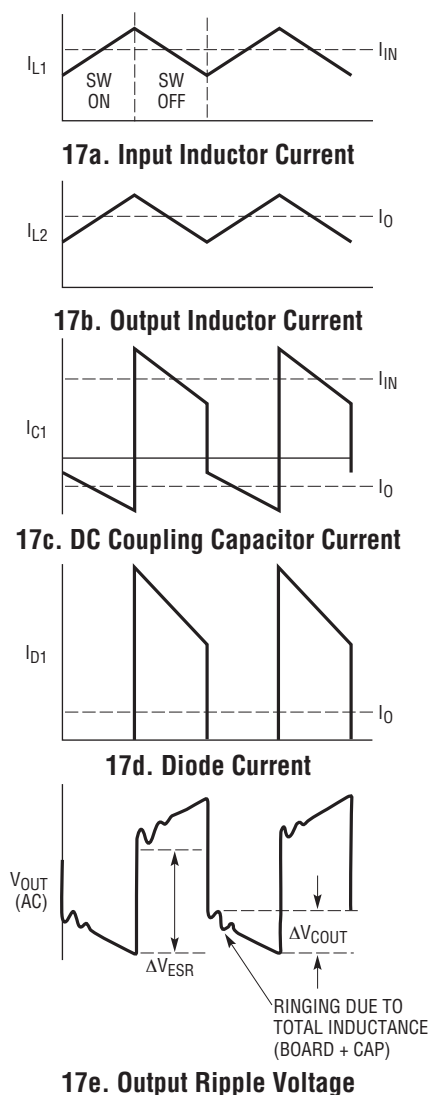

Figure 17. SEPIC Converter Switching Waveforms

The choice of component(s) begins with the maximum acceptable ripple voltage (expressed as a percentage of the output voltage), and how this ripple should be divided between the ESR step and the charging/discharging ΔV . For the purpose of simplicity we will choose 2% for the maximum output ripple, to be divided equally between the ESR step and the charging/discharging ΔV . This percentage ripple will change, depending on the requirements of the application, and the equations provided below can easily be modified.

For a 1% contribution to the total ripple voltage, the ESR of the output capacitor can be determined using the following equation:

$$ESR_{COUT} \leq \frac{0.01 \cdot V_O}{I_{D(PEAK)}}$$

where:

$$I_{D(PEAK)} = \left(1 + \frac{\chi}{2}\right) \cdot I_{O(MAX)} \cdot \left(\frac{V_O + V_D}{V_{IN(MIN)}} + 1\right)$$

For the bulk C component, which also contributes 1% to the total ripple:

$$C_{OUT} \geq \frac{I_{O(MAX)}}{0.01 \cdot V_O \cdot f}$$

For many designs it is possible to choose a single capacitor type that satisfies both the ESR and bulk C requirements for the design. In certain demanding applications, however, the ripple voltage can be improved significantly by connecting two or more types of capacitors in parallel. For example, using a low ESR ceramic capacitor can minimize the ESR step, while an electrolytic or tantalum capacitor can be used to supply the required bulk C.

Once the output capacitor ESR and bulk capacitance have been determined, the overall ripple voltage waveform should be verified on a dedicated PC board (see Board Layout section for more information on component placement). Lab breadboards generally suffer from excessive series inductance (due to inter-component wiring), and these parasitics can make the switching waveforms look significantly worse than they would be on a properly designed PC board.

APPLICATIONS INFORMATION

The output capacitor in a SEPIC regulator experiences high RMS ripple currents, as shown in Figure 17. The RMS output capacitor ripple current is:

$$I_{\text{RMS(COUT)}} = I_{\text{O(MAX)}} \cdot \sqrt{\frac{V_{\text{O}}}{V_{\text{IN(MIN)}}}}$$

Note that the ripple current ratings from capacitor manufacturers are often based on only 2000 hours of life. This makes it advisable to further derate the capacitor or to choose a capacitor rated at a higher temperature than required. Several capacitors may also be placed in parallel to meet size or height requirements in the design.

Manufacturers such as Nichicon, United Chemicon and Sanyo should be considered for high performance through-hole capacitors. The OS-CON semiconductor dielectric capacitor available from Sanyo has the lowest product of ESR and size of any aluminum electrolytic, at a somewhat higher price.

In surface mount applications, multiple capacitors may have to be placed in parallel in order to meet the ESR or RMS current handling requirements of the application. Aluminum electrolytic and dry tantalum capacitors are both available in surface mount packages. In the case of tantalum, it is critical that the capacitors have been surge tested for use in switching power supplies. An excellent choice is AVX TPS series of surface mount tantalum. Also, ceramic capacitors are now available with extremely low ESR, ESL and high ripple current ratings.

SEPIC Converter: Input Capacitor Selection

The input capacitor of a SEPIC converter is less critical than the output capacitor due to the fact that an inductor is in series with the input and the input current waveform is triangular in shape. The input voltage source impedance determines the size of the input capacitor which is typically in the range of 10 μ F to 100 μ F. A low ESR capacitor is recommended, although it is not as critical as for the output capacitor.

The RMS input capacitor ripple current for a SEPIC converter is:

$$I_{\text{RMS(CIN)}} = \frac{1}{\sqrt{12}} \cdot \Delta I_{\text{L}}$$

Please note that the input capacitor can see a very high surge current when a battery is suddenly connected to the input of the converter and solid tantalum capacitors can fail catastrophically under these conditions. **Be sure to specify surge-tested capacitors!**

SEPIC Converter: Selecting the DC Coupling Capacitor

The coupling capacitor C1 in Figure 16 sees nearly a rectangular current waveform as shown in Figure 17. During the switch off-time the current through C1 is $I_{\text{O}}(V_{\text{O}}/V_{\text{IN}})$ while approximately $-I_{\text{O}}$ flows during the on-time. This current waveform creates a triangular ripple voltage on C1:

$$\Delta V_{\text{C1(P-P)}} = \frac{I_{\text{O(MAX)}}}{\text{C1} \cdot f} \cdot \frac{V_{\text{O}}}{V_{\text{IN}} + V_{\text{O}} + V_{\text{D}}}$$

The maximum voltage on C1 is then:

$$V_{\text{C1(MAX)}} = V_{\text{IN}} + \frac{\Delta V_{\text{C1(P-P)}}}{2}$$

which is typically close to $V_{\text{IN(MAX)}}$. The ripple current through C1 is:

$$I_{\text{RMS(C1)}} = I_{\text{O(MAX)}} \cdot \sqrt{\frac{V_{\text{O}} + V_{\text{D}}}{V_{\text{IN(MIN)}}}}$$

The value chosen for the DC coupling capacitor normally starts with the minimum value that will satisfy 1) the RMS current requirement and 2) the peak voltage requirement (typically close to V_{IN}). Low ESR ceramic and tantalum capacitors work well here.

SEPIC Converter Design Example

The design example given here will be for the circuit shown in Figure 18. The input voltage is 5V to 15V and the output is 12V at a maximum load current of 1.5A (2A peak).

1. The duty cycle range is:

$$D = \left(\frac{V_{\text{O}} + V_{\text{D}}}{V_{\text{IN}} + V_{\text{O}} + V_{\text{D}}} \right) = 45.5\% \text{ to } 71.4\%$$

2. The operating mode chosen is pulse skipping, so the MODE/SYNC pin is shorted to INTV_{CC}.

APPLICATIONS INFORMATION

- The operating frequency is chosen to be 300kHz to reduce the size of the inductors; the resistor from the FREQ pin to ground is 80k.
- An inductor ripple current of 40% is chosen, so the peak input current (which is also the minimum saturation current) is:

$$I_{L1(\text{PEAK})} = \left(1 + \frac{\chi}{2}\right) \cdot I_{O(\text{MAX})} \cdot \frac{V_O + V_D}{V_{IN(\text{MIN})}}$$

$$= \left(1 + \frac{0.4}{2}\right) \cdot 1.5 \cdot \frac{12 + 0.5}{5} = 4.5\text{A}$$

The inductor ripple current is:

$$\Delta I_L = \chi \cdot I_{O(\text{MAX})} \cdot \frac{D_{\text{MAX}}}{1 - D_{\text{MAX}}}$$

$$= 0.4 \cdot 1.5 \cdot \frac{0.714}{1 - 0.714} = 1.5\text{A}$$

And so the inductor value is:

$$L = \frac{V_{IN(\text{MIN})}}{2 \cdot \Delta I_L \cdot f} \cdot D_{\text{MAX}} = \frac{5}{2 \cdot 1.5 \cdot 300\text{k}} \cdot 0.714 = 4\mu\text{H}$$

The component chosen is a BH Electronics BH510-1007, which has a saturation current of 8A.

- With an minimum input voltage of 5V, only logic-level power MOSFETs should be considered. Because the maximum duty cycle is 71.4%, the maximum SENSE pin threshold voltage is reduced from its low duty cycle typical value of 150mV to approximately 120mV. Assuming a MOSFET junction temperature of 125°C, the room temperature MOSFET $R_{DS(\text{ON})}$ should be less than:

$$R_{DS(\text{ON})} \leq \frac{V_{\text{SENSE}(\text{MAX})}}{I_{O(\text{MAX})}} \cdot \frac{1}{\left(1 + \frac{\chi}{2}\right) \cdot P_T} \cdot \frac{1}{\left(\frac{V_O + V_D}{V_{IN(\text{MIN})}}\right) + 1}$$

$$= \frac{0.12}{1.5} \cdot \frac{1}{1.2 \cdot 1.5} \cdot \frac{1}{\left(\frac{12.5}{5}\right) + 1} = 12.7\text{m}\Omega$$

For a SEPIC converter, the switch BV_{DSS} rating must be greater than $V_{IN(\text{MAX})} + V_O$, or 27V. This comes close to an IRF7811W, which is rated to 30V, and has a maximum room temperature $R_{DS(\text{ON})}$ of 12mΩ at $V_{GS} = 4.5\text{V}$.

- The diode for this design must handle a maximum DC output current of 2A and be rated for a minimum reverse voltage of $V_{IN} + V_{OUT}$, or 27V. A 3A, 40V diode from International Rectifier (30BQ040) is chosen for its small size, relatively low forward drop and acceptable reverse leakage at high temp.
- The output capacitor usually consists of a high valued bulk C connected in parallel with a lower valued, low ESR ceramic. Based on a maximum output ripple voltage of 1%, or 120mV, the bulk C needs to be greater than:

$$C_{\text{OUT}} \geq \frac{I_{\text{OUT}(\text{MAX})}}{0.01 \cdot V_{\text{OUT}} \cdot f} =$$

$$\frac{1.5\text{A}}{0.01 \cdot 12\text{V} \cdot 300\text{kHz}} = 41\mu\text{F}$$

The RMS ripple current rating for this capacitor needs to exceed:

$$I_{\text{RMS}(\text{COUT})} \geq I_{O(\text{MAX})} \cdot \sqrt{\frac{V_O}{V_{IN(\text{MIN})}}} =$$

$$1.5\text{A} \cdot \sqrt{\frac{12\text{V}}{5\text{V}}} = 2.3\text{A}$$

To satisfy this high RMS current demand, two 47μF Kemet capacitors (T495X476K020AS) are required. As a result, the output ripple voltage is a low 50mV to 60mV. In parallel with these tantalums, two 10μF, low ESR (X5R) Taiyo Yuden ceramic capacitors (TMK432BJ106MM) are added for HF noise reduction. Check the output ripple with a single oscilloscope probe connected directly across the output capacitor terminals, where the HF switching currents flow.

- The choice of an input capacitor for a SEPIC converter depends on the impedance of the source supply and the amount of input ripple the converter will safely tolerate. For this particular design and lab setup, a single 47μF Kemet tantalum capacitor (T495X476K020AS) is adequate. As with the output node, check the input ripple with a single oscilloscope probe connected across the input capacitor terminals. If any HF switching noise is observed it is a good idea to decouple the input with a low ESR, X5R ceramic capacitor as close to the V_{IN} and GND pins as possible.

APPLICATIONS INFORMATION

9. The DC coupling capacitor in a SEPIC converter is chosen based on its RMS current requirement and must be rated for a minimum voltage of V_{IN} plus the AC ripple voltage. Start with the minimum value which satisfies the RMS current requirement and then check the ripple voltage to ensure that it doesn't exceed the DC rating.

For this design a single 10 μ F, low ESR (X5R) Taiyo Yuden ceramic capacitor (TMK432BJ106MM) is adequate.

$$I_{RMS(CI)} \geq I_{O(MAX)} \cdot \sqrt{\frac{V_O + V_D}{V_{IN(MIN)}}}$$

$$= 1.5A \cdot \sqrt{\frac{12V + 0.5V}{5V}} = 2.4A$$

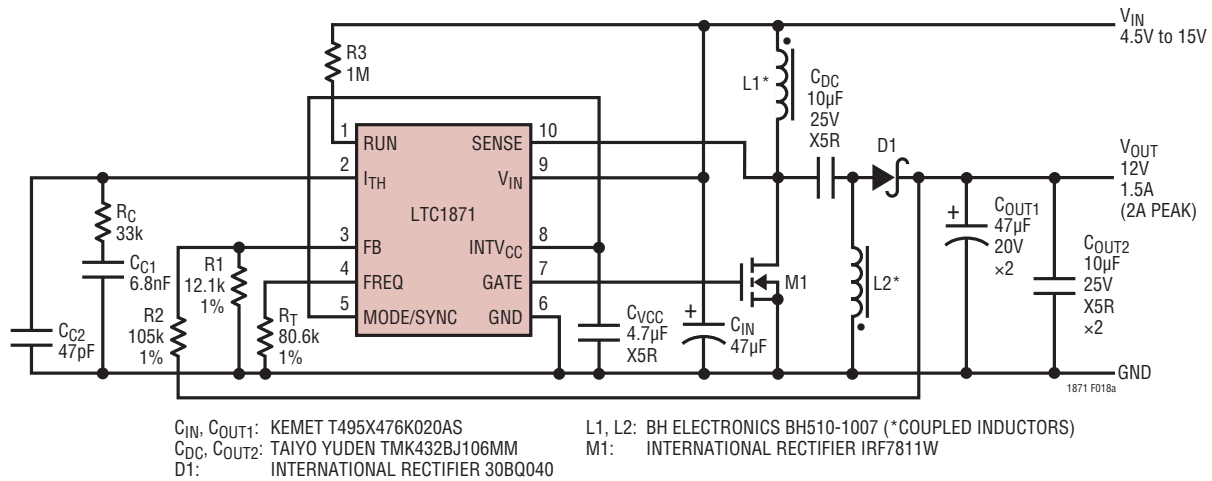

Figure 18a. 4.5V to 15V Input, 12V/2A Output SEPIC Converter

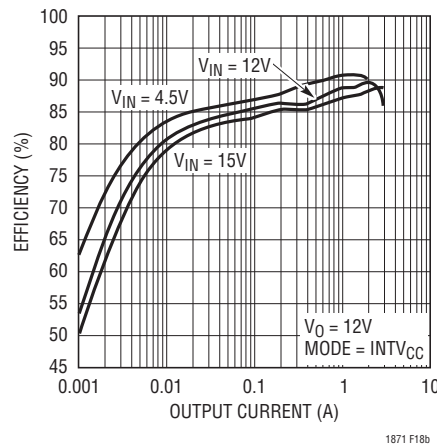

Figure 18b. SEPIC Efficiency vs Output Current

APPLICATIONS INFORMATION

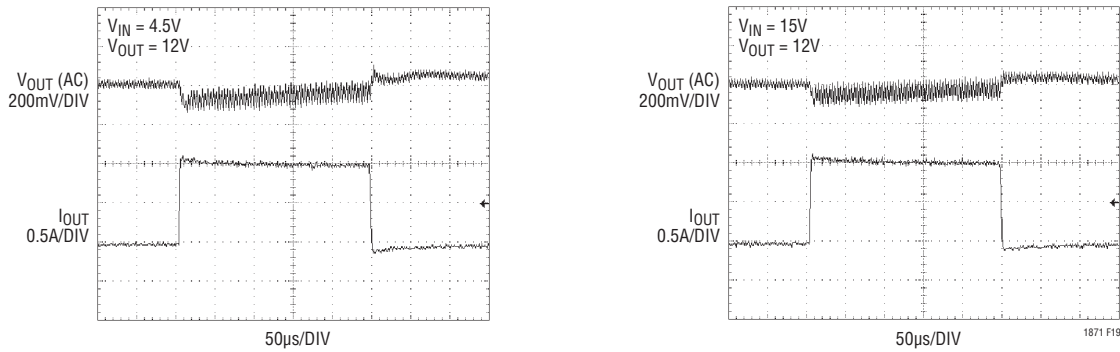
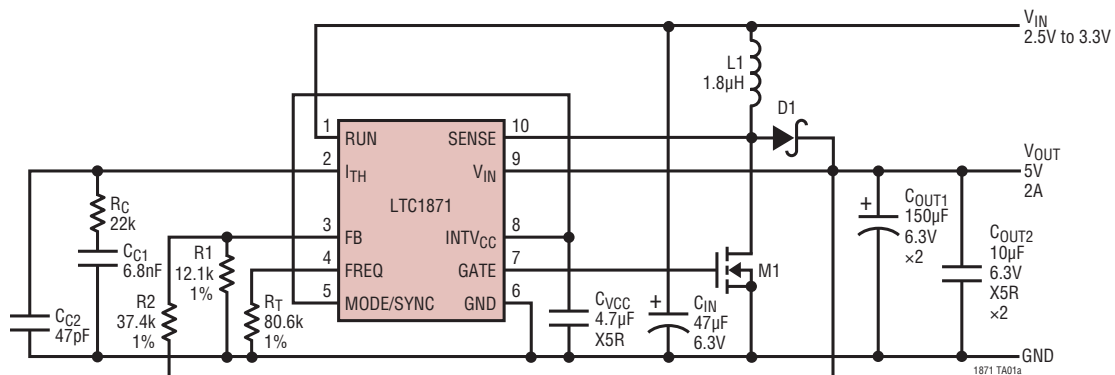

Figure 19. LTC1871 SEPIC Converter Load Step Response

TYPICAL APPLICATIONS

2.5V to 3.3V Input, 5V/2A Output Boost Converter



- C_{IN}: SANYO POSCAP 6TPA47M
- C_{OUT1}: SANYO POSCAP 6TPB150M
- C_{OUT2}: TAIYO YUDEN JMK316BJ106ML
- C_{VCC}: TAIYO YUDEN LMK316BJ475ML
- D1: INTERNATIONAL RECTIFIER 30BQ015
- L1: TOKO DS104C2 B952AS-1R8N
- M1: SILICONIX/VISHAY Si9426

Output Efficiency at 2.5V and 3.3V Input

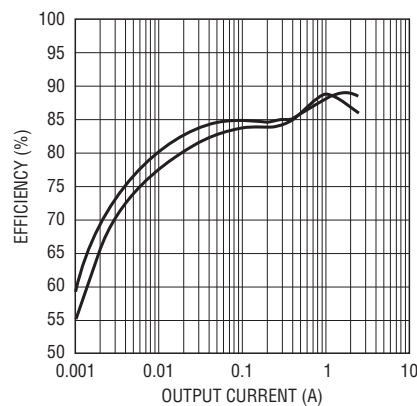

1871 TA01b

TYPICAL APPLICATIONS

18V to 27V Input, 28V Output, 400W 2-Phase, Low Ripple, Synchronized RF Base Station Power Supply (Boost)

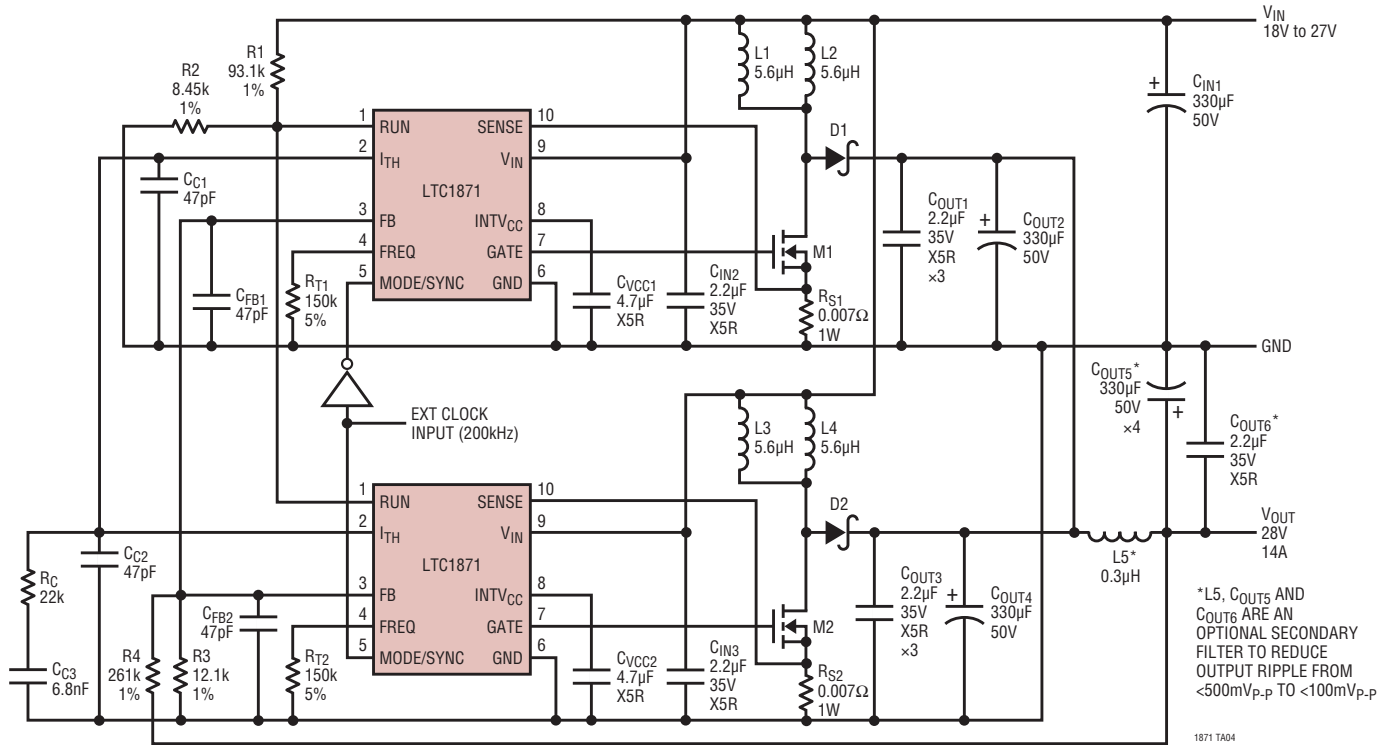

- CIN1: SANYO 50MV330AX
- CIN2, 3: TAIYO YUDEN GMK325BJ225MN
- COUT2, 4, 5: SANYO 50MV330AX
- COUT1, 3, 6: TAIYO YUDEN GMK325BJ225MN
- CVCC1, 2: TAIYO YUDEN LMK316BJ475ML
- L1 TO L4: SUMIDA CEP125-5R6MC-HD
- L5: SUMIDA CEP125-0R3NC-ND
- D1, D2: ON SEMICONDUCTOR MBR2045CT
- M1, M2: INTERNATIONAL RECTIFIER IRLZ44NS

1871 TA04

*L5, COUT5 AND COUT6 ARE AN OPTIONAL SECONDARY FILTER TO REDUCE OUTPUT RIPPLE FROM <math><500\text{mV}_{\text{p-p}}\text{ TO }<100\text{mV}_{\text{p-p}}</math>

5V to 12V Input, $\pm 12\text{V}/0.2\text{A}$ Output SEPIC Converter with Undervoltage Lockout

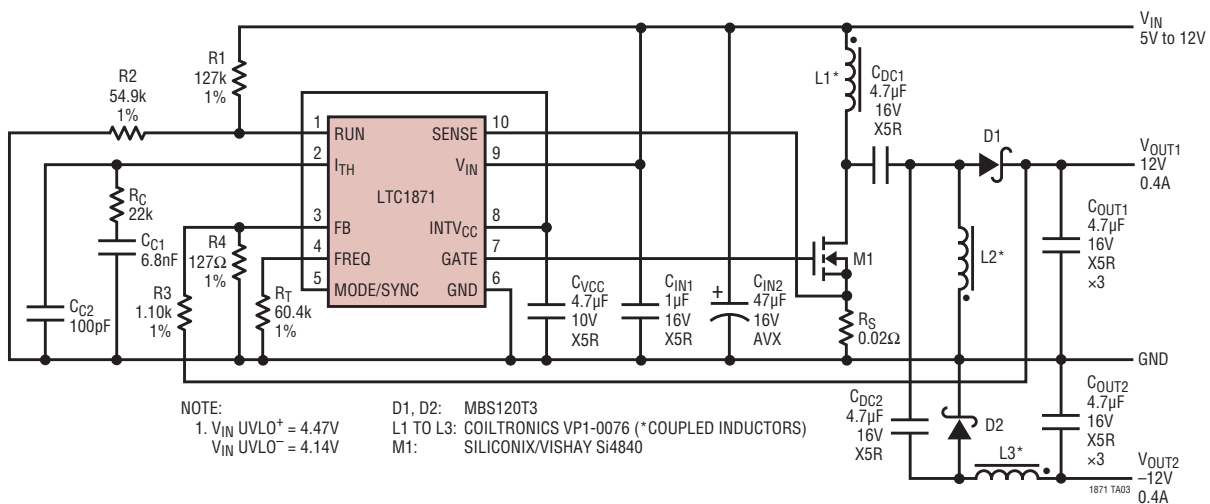

NOTE:
1. $V_{\text{IN UVLO}^+} = 4.47\text{V}$
 $V_{\text{IN UVLO}^-} = 4.14\text{V}$

- D1, D2: MBS120T3
- L1 TO L3: COILTRONICS VP1-0076 (*COUPLED INDUCTORS)
- M1: SILICONIX/VISHAY Si4840

1871 TA03

TYPICAL APPLICATIONS

4.5V to 28V Input, 5V/2A Output SEPIC Converter with Undervoltage Lockout and Soft-Start

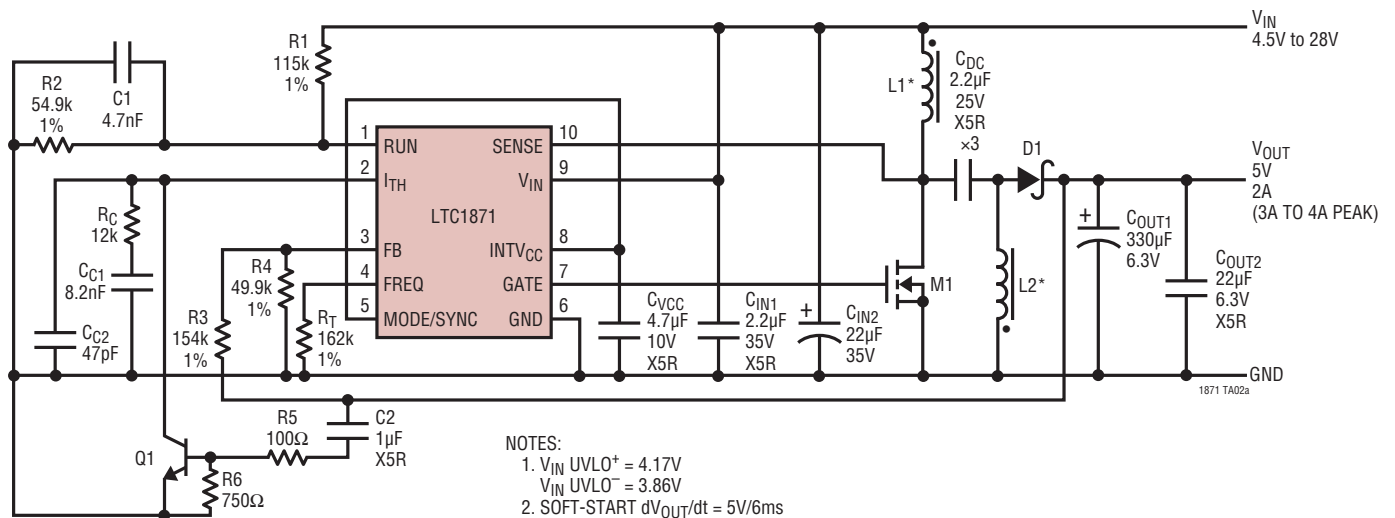

C_{IN1}, C_{DC} : TAIYO YUDEN GMK325BJ225MN
 C_{IN2} : AVX TPSE226M035R0300
 C_{OUT1} : SANYO 6TPB330M
 C_{OUT2} : TAIYO YUDEN JMK325BJ226MN
 C_{VCC} : LMK316BJ475ML

D1: INTERNATIONAL RECTIFIER 30BQ040
 L1, L2: BH ELECTRONICS BH510-1007 (*COUPLED INDUCTORS)
 M1: SILICONIX/VISHAY Si4840
 Q1: PHILIPS BC847BF

Soft-Start

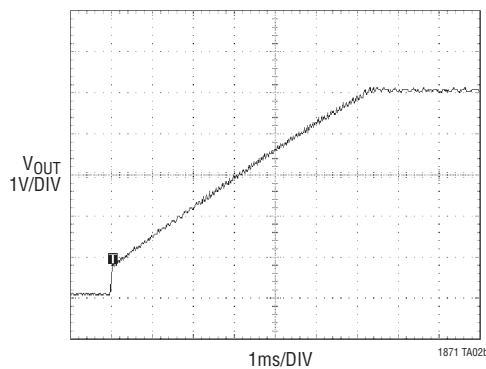

Load Step Response at $V_{IN} = 4.5V$

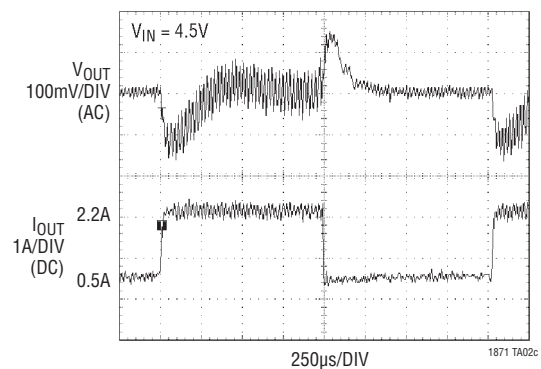

Load Step Response at $V_{IN} = 28V$

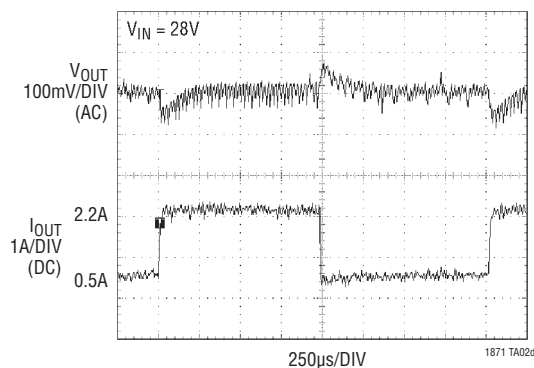

TYPICAL APPLICATIONS

5V to 15V Input, -5V/5A Output Positive-to-Negative Converter with Undervoltage Lockout and Level-Shifted Feedback

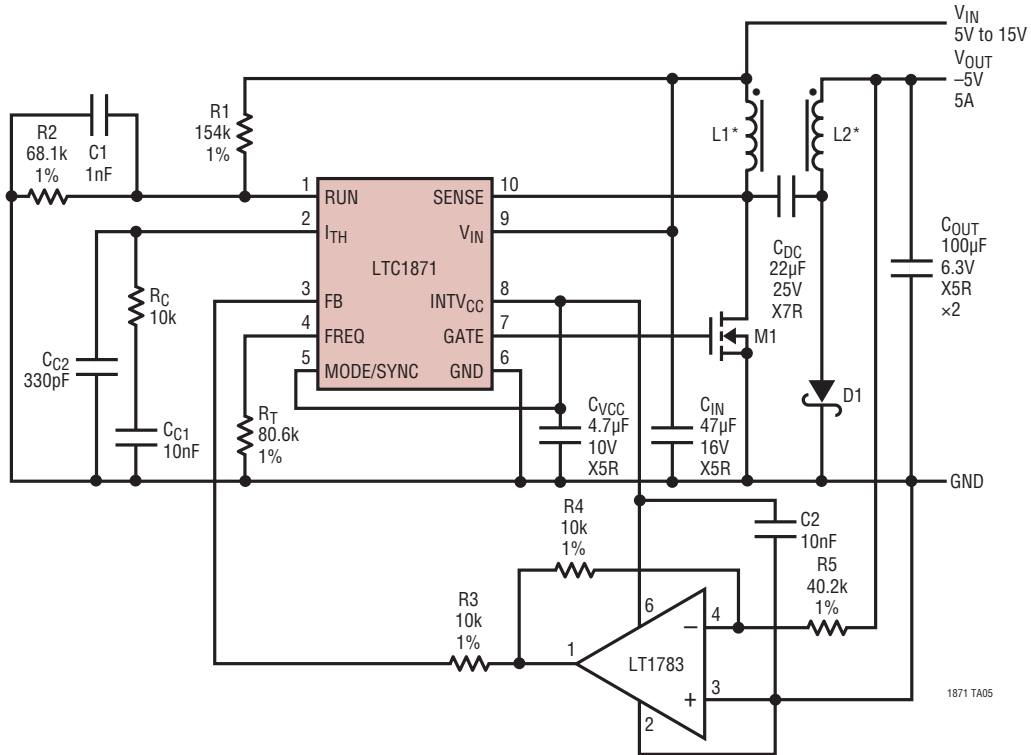

- | | |
|----------------------------------------------|-----------------------------------------------------------------------------------------------------|
| C _{IN} : TDK C5750X5R1C476M | D1: ON SEMICONDUCTOR MBRB2035CT |
| C _{DC} : TDK C5750X7R1E226M | L1, L2: COILTRONICS VP5-0053 (*3 WINDINGS IN PARALLEL FOR THE PRIMARY, 3 IN PARALLEL FOR SECONDARY) |
| C _{OUT} : TDK C5750X5R0J107M | M1: INTERNATIONAL RECTIFIER IRF7822 |
| C _{VCC} : TAIYO YUDEN LMK316BJ475ML | |

1871 TA05

PACKAGE DESCRIPTION

MS Package
10-Lead Plastic MSOP
 (Reference LTC DWG # 05-08-1661 Rev E)

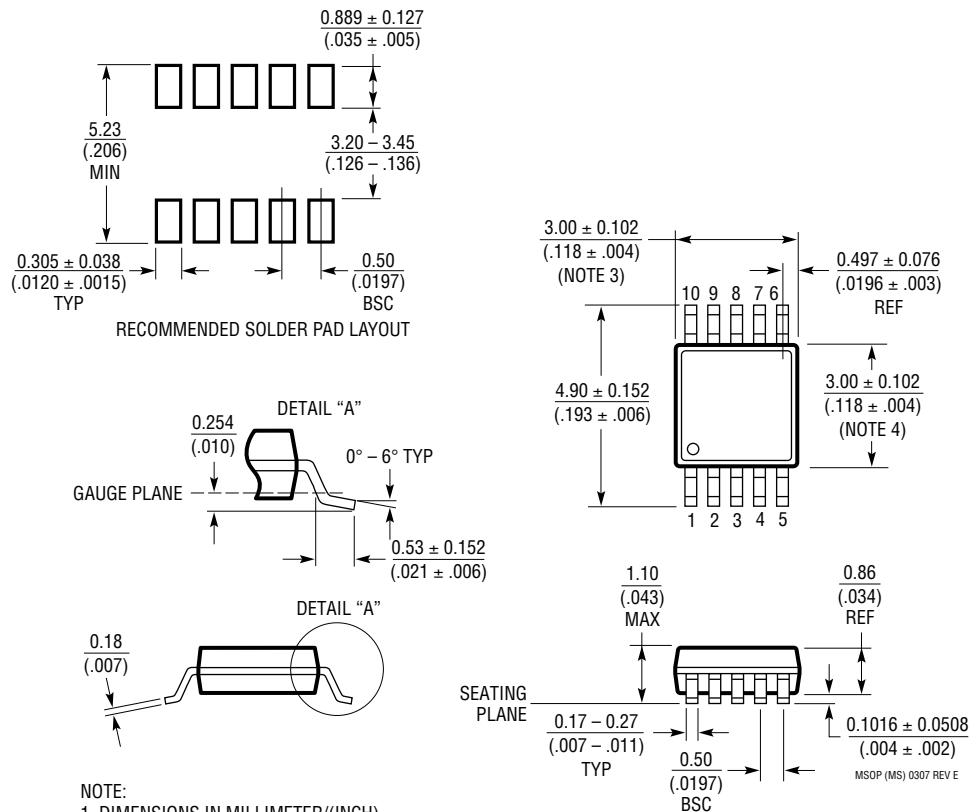

NOTE:

1. DIMENSIONS IN MILLIMETER/(INCH)
2. DRAWING NOT TO SCALE
3. DIMENSION DOES NOT INCLUDE MOLD FLASH, PROTRUSIONS OR GATE BURRS.
MOLD FLASH, PROTRUSIONS OR GATE BURRS SHALL NOT EXCEED 0.152mm (.006") PER SIDE
4. DIMENSION DOES NOT INCLUDE INTERLEAD FLASH OR PROTRUSIONS.
INTERLEAD FLASH OR PROTRUSIONS SHALL NOT EXCEED 0.152mm (.006") PER SIDE
5. LEAD COPLANARITY (BOTTOM OF LEADS AFTER FORMING) SHALL BE 0.102mm (.004") MAX

TYPICAL APPLICATION

High Power SLIC Supply with Undervoltage Lockout
(Also See the LTC3704 Data Sheet)

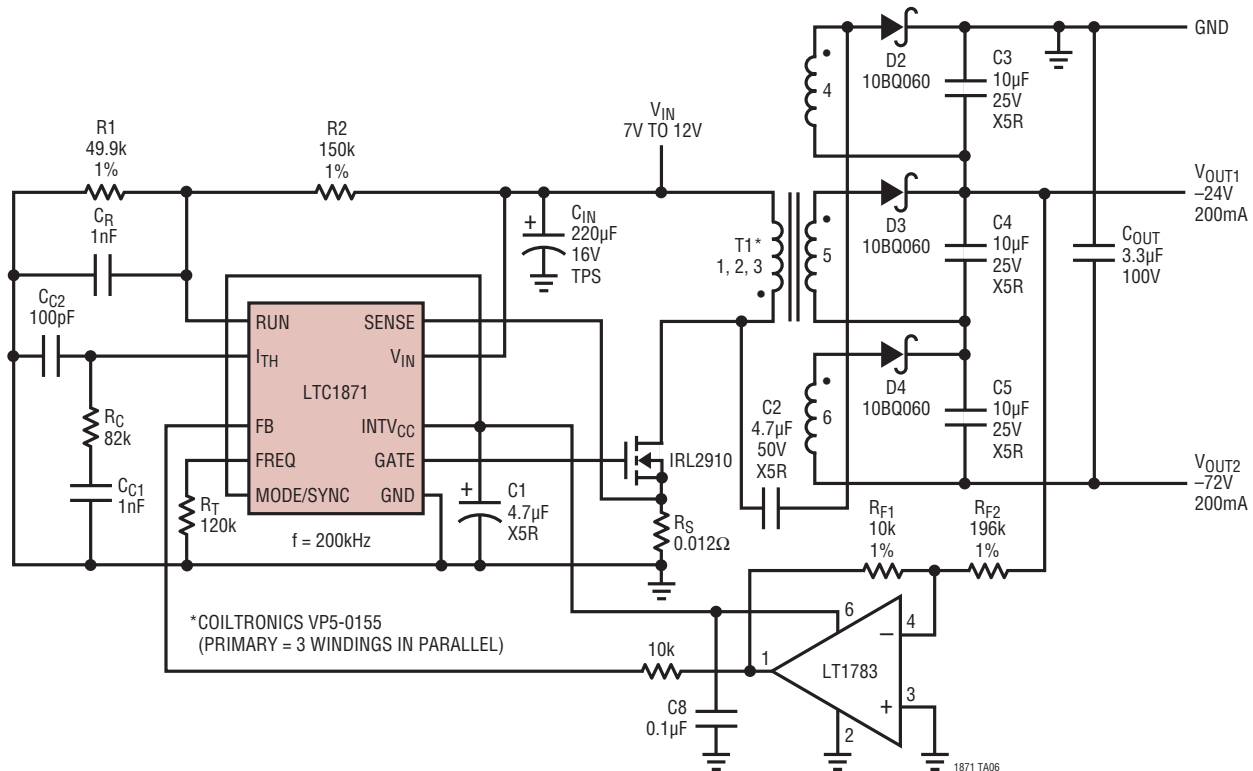

RELATED PARTS

| PART NUMBER | DESCRIPTION | COMMENTS |
|----------------------|------------------------------------------------------|----------------------------------------------------------------------------------------|
| LT [®] 1619 | Current Mode PWM Controller | 300kHz Fixed Frequency, Boost, SEPIC, Flyback Topology |
| LTC1624 | Current Mode DC/DC Controller | SO-8; 300kHz Operating Frequency; Buck, Boost, SEPIC Design; V _{IN} Up to 36V |
| LTC1700 | No R _{SENSE} Synchronous Step-Up Controller | Up to 95% Efficiency, Operation as Low as 0.9V Input |
| LTC1871-7 | Wide Input Range Controller | No R _{SENSE} , 7V Gate Drive, Current Mode Control |
| LTC1872 | SOT-23 Boost Controller | Delivers Up to 5A, 550kHz Fixed Frequency, Current Mode |
| LT1930 | 1.2MHz, SOT-23 Boost Converter | Up to 34V Output, 2.6V ≤ V _{IN} ≤ 16V, Miniature Design |
| LT1931 | Inverting 1.2MHz, SOT-23 Converter | Positive-to-Negative DC/DC Conversion, Miniature Design |
| LTC3401/LTC3402 | 1A/2A 3MHz Synchronous Boost Converters | Up to 97% Efficiency, Very Small Solution, 0.5V ≤ V _{IN} ≤ 5V |
| LTC3704 | Positive-to-Negative DC/DC Controller | No R _{SENSE} , Current Mode Control, 50kHz to 1MHz |
| LT3782 | 2-Phase Step-Up DC/DC Controller | 6V ≤ V _{IN} ≤ 40V; 4A Gate Drive, 150kHz to 500kHz |

Looking for pricing, stock, or lifecycle information?

Click below to explore more details on WIN SOURCE:

 [View LTC1871IMS#TRPBF on WIN SOURCE](#)

 [Linear Technology](#) Information

Optimize Your Supply Chain with WIN SOURCE Solutions

-  Global Sourcing Solution
-  Obsolete Management
-  Cost Control Management
-  Shortage Management
-  Alternative Solution
-  Excess Inventory Management