



**THE DATASHEET OF  
LTC3400BES6#TR**



## FEATURES

- Up to 92% Efficiency
- Generates 3.3V at 100mA from a Single AA Cell
- Low Start-Up Voltage: 0.85V
- 1.2MHz Fixed Frequency Switching
- Internal Synchronous Rectifier
- 2.5V to 5V Output Range
- Automatic Burst Mode® Operation (LTC3400)
- Continuous Switching at Light Loads (LTC3400B)
- Logic Controlled Shutdown (<1µA)
- Antiringing Control Minimizes EMI
- Tiny External Components
- Low Profile (1mm) SOT-23 Package

## APPLICATIONS

- Pagers
- MP3 Players
- Digital Cameras
- LCD Bias Supplies
- Handheld Instruments
- Wireless Handsets
- GPS Receivers

## DESCRIPTION

The LTC®3400/LTC3400B are synchronous, fixed frequency, step-up DC/DC converters delivering high efficiency in a 6-lead ThinSOT™ package. Capable of supplying 3.3V at 100mA from a single AA cell input, the devices contain an internal NMOS switch and PMOS synchronous rectifier.

A switching frequency of 1.2MHz minimizes solution footprint by allowing the use of tiny, low profile inductors and ceramic capacitors. The current mode PWM design is internally compensated, reducing external parts count. The LTC3400 features automatic shifting to power saving Burst Mode operation at light loads, while the LTC3400B features continuous switching at light loads. Antiringing control circuitry reduces EMI concerns by damping the inductor in discontinuous mode, and the devices feature low shutdown current of under 1µA.

Both devices are available in the low profile (1mm) SOT-23 package.

LT, LTC, LT and Burst Mode are registered trademarks of Linear Technology Corporation. ThinSOT is a trademark of Linear Technology Corporation.

## TYPICAL APPLICATION

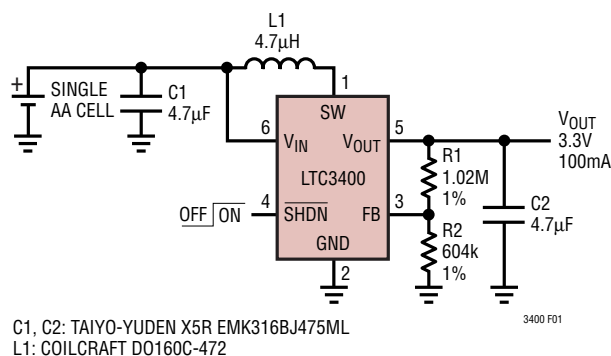
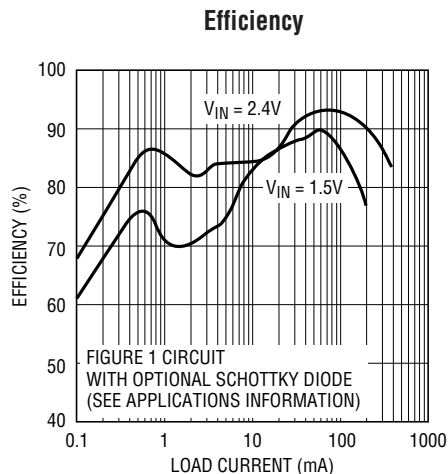

Figure 1. Single Cell to 3.3V Synchronous Boost Converter



## ABSOLUTE MAXIMUM RATINGS

(Note 1)

$V_{IN}$ Voltage .....	-0.3V to 6V
SW Voltage .....	-0.3V to 6V
SHDN, FB Voltage .....	-0.3V to 6V
$V_{OUT}$ .....	-0.3V to 6V
Operating Temperature Range (Note 2) ..	-30°C to 85°C
Storage Temperature Range .....	-65°C to 125°C
Lead Temperature (Soldering, 10 sec) .....	300°C

## PACKAGE/ORDER INFORMATION

	ORDER PART NUMBER
	LTC3400ES6 LTC3400BES6
	S6 PART MARKING
	LTWK LTUN

Consult LTC Marketing for parts specified with wider operating temperature ranges.

## ELECTRICAL CHARACTERISTICS

The ● denotes the specifications which apply over the full operating temperature range, otherwise specifications are at  $T_A = 25^\circ\text{C}$ .  $V_{IN} = 1.2\text{V}$ ,  $V_{OUT} = 3.3\text{V}$ , unless otherwise specified.

PARAMETER	CONDITIONS	MIN	TYP	MAX	UNITS
Minimum Start-Up Voltage	$I_{LOAD} = 1\text{mA}$		0.85	1	V
Minimum Operating Voltage	$\overline{\text{SHDN}} = V_{IN}$ (Note 4)		0.5	0.65	V
Output Voltage Adjust Range		2.5		5	V
Feedback Voltage		● 1.192	1.23	1.268	V
Feedback Input Current	$V_{FB} = 1.25\text{V}$ (Note 3)		1		nA
Quiescent Current (Burst Mode Operation)	$V_{FB} = 1.4\text{V}$ (Note 5), LTC3400 Only		19	30	$\mu\text{A}$
Quiescent Current (Shutdown)	$\overline{\text{VSHDN}} = 0\text{V}$ , Not Including Switch Leakage		0.01	1	$\mu\text{A}$
Quiescent Current (Active)	Measured On $V_{OUT}$		300	500	$\mu\text{A}$
NMOS Switch Leakage	$V_{SW} = 5\text{V}$		0.1	5	$\mu\text{A}$
PMOS Switch Leakage	$V_{SW} = 0\text{V}$		0.1	5	$\mu\text{A}$
NMOS Switch On Resistance	$V_{OUT} = 3.3\text{V}$ $V_{OUT} = 5\text{V}$		0.35 0.20		$\Omega$ $\Omega$
PMOS Switch On Resistance	$V_{OUT} = 3.3\text{V}$ $V_{OUT} = 5\text{V}$		0.45 0.30		$\Omega$ $\Omega$
NMOS Current Limit		600	850		mA
Burst Mode Operation Current Threshold	LTC3400 Only (Note 3)		3		mA
Current Limit Delay to Output	(Note 3)		40		ns
Max Duty Cycle	$V_{FB} = 1.15\text{V}$	● 80	87		%
Switching Frequency		● 0.95 ● 0.85	1.2 1.2	1.5 1.5	MHz MHz
SHDN Input High		1			V
SHDN Input Low				0.35	V
SHDN Input Current	$\overline{\text{VSHDN}} = 5.5\text{V}$		0.01	1	$\mu\text{A}$

**Note 1:** Absolute Maximum Ratings are those values beyond which the life of a device may be impaired.

**Note 2:** The LTC3400E/LTC3400BE are guaranteed to meet performance specifications from 0°C to 70°C. Specifications over the -30°C to 85°C operating temperature range are assured by design, characterization and correlation with statistical process controls.

**Note 3:** Specification is guaranteed by design and not 100% tested in production.

**Note 4:** Minimum  $V_{IN}$  operation after start-up is only limited by the battery's ability to provide the necessary power as it enters a deeply discharged state.

**Note 5:** Burst Mode operation  $I_Q$  is measured at  $V_{OUT}$ . Multiply this value by  $V_{OUT}/V_{IN}$  to get the equivalent input (battery) current.

# TYPICAL PERFORMANCE CHARACTERISTICS

**Output Load Burst Mode Threshold vs  $V_{IN}$**

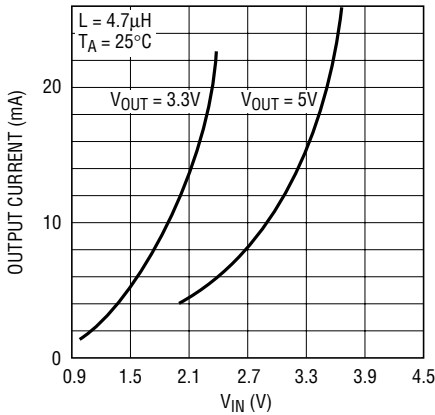

3400 G01

**$V_{OUT}$  vs Temperature**

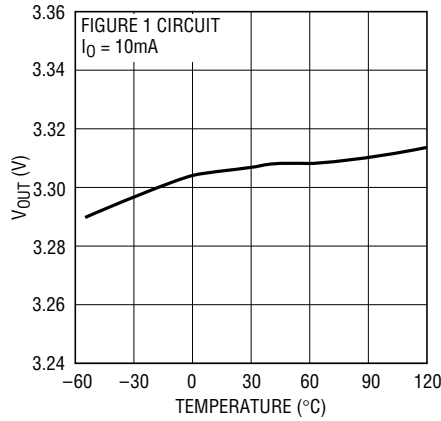

3400 G02

**Minimum Start-Up Voltage vs Load Current**

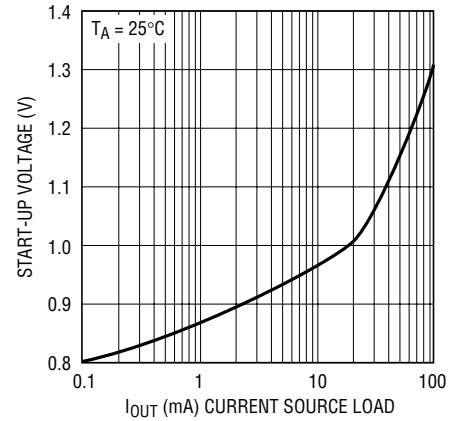

3400 G03

**No Load Battery Current vs  $V_{BATT}$**

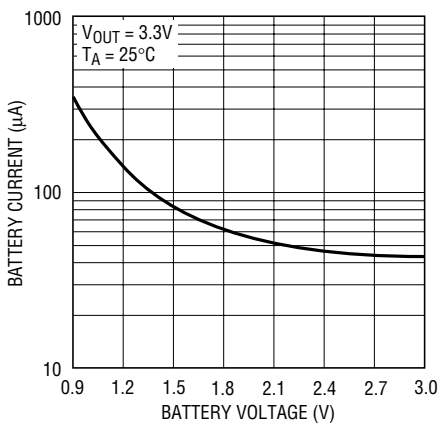

3400 G04

**Normalized Oscillator Frequency vs Temperature**

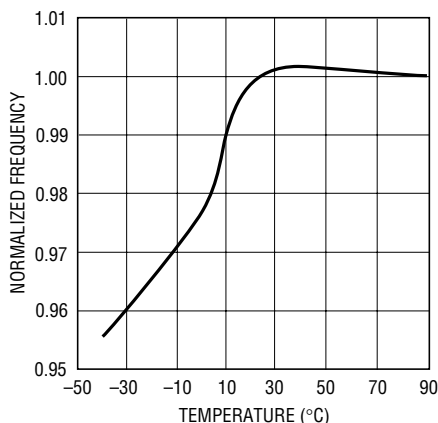

3400 G05

**SW Pin Antiringing Operation**

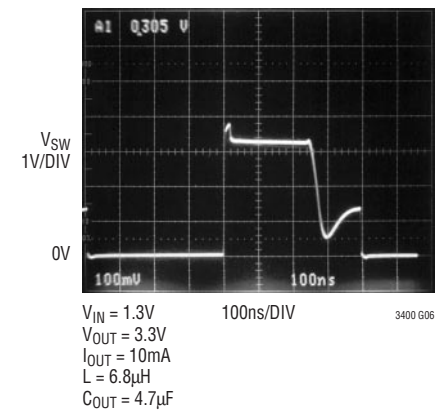

3400 G06

**SW Pin Fixed Frequency, Continuous Inductor Current Operation**

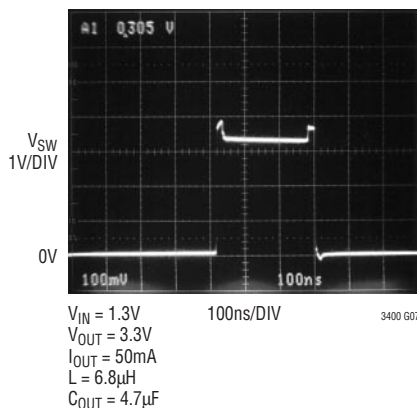

3400 G07

**Fixed Frequency and Burst Mode Operation**

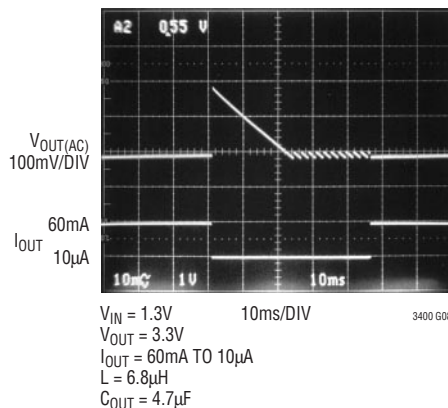

3400 G08

**$V_{OUT}$  Transient Response**

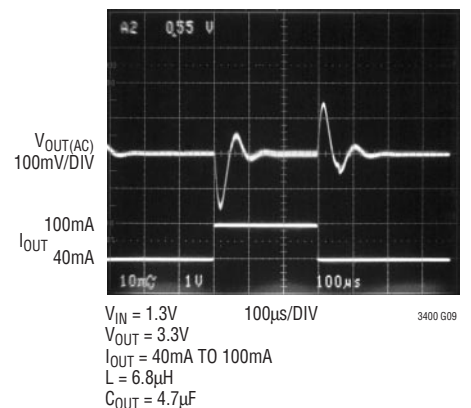

3400fa

## PIN FUNCTIONS

**SW (Pin 1):** Switch Pin. Connect inductor between SW and  $V_{IN}$ . Optional Schottky diode is connected between SW and  $V_{OUT}$ . Keep these PCB trace lengths as short and wide as possible to reduce EMI and voltage overshoot. If the inductor current falls to zero, or  $\overline{\text{SHDN}}$  is low, an internal  $100\Omega$  antiringing switch is connected from SW to  $V_{IN}$  to minimize EMI.

**GND (Pin 2):** Signal and Power Ground. Provide a short direct PCB path between GND and the (-) side of the output capacitor(s).

**FB (Pin 3):** Feedback Input to the  $g_m$  Error Amplifier. Connect resistor divider tap to this pin. The output voltage can be adjusted from 2.5V to 5V by:

$$V_{OUT} = 1.23V \cdot [1 + (R1/R2)]$$

**SHDN (Pin 4):** Logic Controlled Shutdown Input.

$\overline{\text{SHDN}}$  = High: Normal free running operation, 1.2MHz typical operating frequency.

$\overline{\text{SHDN}}$  = Low: Shutdown, quiescent current  $< 1\mu\text{A}$ .  $100\Omega$  connected between SW and  $V_{IN}$ .

Typically,  $\overline{\text{SHDN}}$  should be connected to  $V_{IN}$  through a 1M pull-up resistor.

**$V_{OUT}$  (Pin 5):** Output Voltage Sense Input and Drain of the Internal Synchronous Rectifier MOSFET. Bias is derived from  $V_{OUT}$ . PCB trace length from  $V_{OUT}$  to the output filter capacitor(s) should be as short and wide as possible.  $V_{OUT}$  is held at  $V_{IN} - 0.6V$  in shutdown due to the body diode of the internal PMOS.

**$V_{IN}$  (Pin 6):** Battery Input Voltage. The device gets its start-up bias from  $V_{IN}$ . Once  $V_{OUT}$  exceeds  $V_{IN}$ , bias comes from  $V_{OUT}$ . Thus, once started, operation is completely independent from  $V_{IN}$ . Operation is only limited by the output power level and the battery's internal series resistance.

## BLOCK DIAGRAM

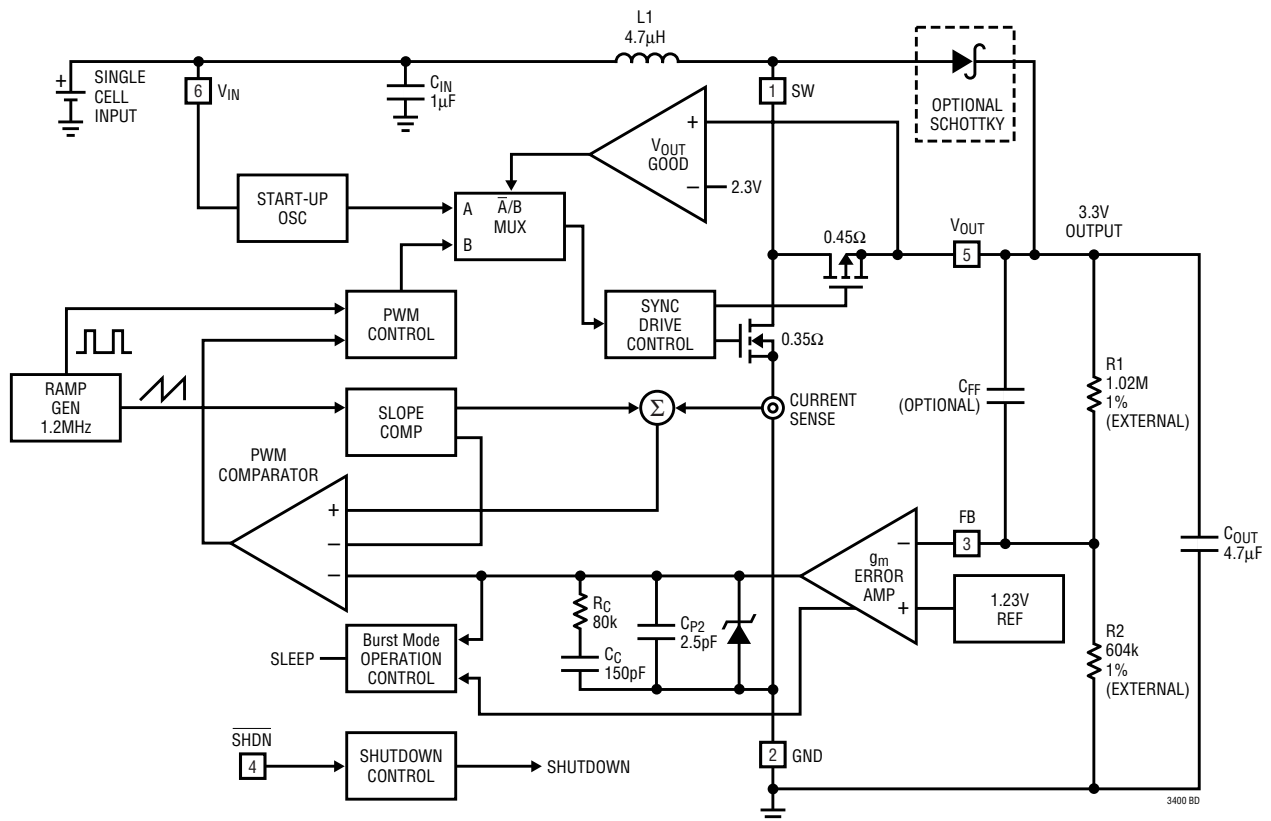

3400fa

## OPERATION

The LTC3400/LTC3400B are 1.2MHz, synchronous boost converters housed in a 6-lead ThinSOT package. Able to operate from an input voltage below 1V, the devices feature fixed frequency, current mode PWM control for exceptional line and load regulation. With its low  $R_{DS(ON)}$  and gate charge internal MOSFET switches, the devices maintain high efficiency over a wide range of load current. Detailed descriptions of the three distinct operating modes follow. Operation can be best understood by referring to the Block Diagram.

### Low Voltage Start-Up

The LTC3400/LTC3400B will start up at a typical  $V_{IN}$  voltage of 0.85V or higher. The low voltage start-up circuitry controls the internal NMOS switch up to a maximum peak inductor current of 850mA (typ), with an approximate 1.5 $\mu$ s off-time during start-up, allowing the devices to start up into an output load. Once  $V_{OUT}$  exceeds 2.3V, the start-up circuitry is disabled and normal fixed frequency PWM operation is initiated. In this mode, the LTC3400/LTC3400B operate independent of  $V_{IN}$ , allowing extended operating time as the battery can droop to several tenths of a volt without affecting output voltage regulation. The limiting factor for the application becomes the ability of the battery to supply sufficient energy to the output.

### Low Noise Fixed Frequency Operation

Oscillator: The frequency of operation is internally set to 1.2MHz.

Error Amp: The error amplifier is an internally compensated transconductance type (current output) with a transconductance ( $g_m$ ) = 33 microsiemens. The internal 1.23V reference voltage is compared to the voltage at the FB pin to generate an error signal at the output of the error amplifier. A voltage divider from  $V_{OUT}$  to ground programs the output voltage via FB from 2.5V to 5V using the equation:

$$V_{OUT} = 1.23V \cdot [1 + (R1/R2)]$$

Current Sensing: A signal representing NMOS switch current is summed with the slope compensator. The summed signal is compared to the error amplifier output

to provide a peak current control command for the PWM. Peak switch current is limited to approximately 850mA independent of input or output voltage. The current signal is blanked for 40ns to enhance noise rejection.

Zero Current Comparator: The zero current comparator monitors the inductor current to the output and shuts off the synchronous rectifier once this current reduces to approximately 20mA. This prevents the inductor current from reversing in polarity improving efficiency at light loads.

Antiringing Control: The antiringing control circuitry prevents high frequency ringing of the SW pin as the inductor current goes to zero by damping the resonant circuit formed by L and  $C_{SW}$  (capacitance on SW pin).

### Burst Mode Operation

Portable devices frequently spend extended time in low power or standby mode, only switching to high power drain when specific functions are enabled. In order to improve battery life in these types of products, high power converter efficiency needs to be maintained over a wide output power range. In addition to its high efficiency at moderate and heavy loads, the LTC3400 includes automatic Burst Mode operation that improves efficiency of the power converter at light loads. Burst mode operation is initiated if the output load current falls below an internally programmed threshold (see Typical Performance graph, Output Load Burst Mode Threshold vs  $V_{IN}$ ). Once initiated, the Burst Mode operation circuitry shuts down most of the device, only keeping alive the circuitry required to monitor the output voltage. This is referred to as the sleep state. In sleep, the LTC3400 draws only 19 $\mu$ A from the output capacitor, greatly enhancing efficiency. When the output voltage has drooped approximately 1% from nominal, the LTC3400 wakes up and commences normal PWM operation. The output capacitor recharges and causes the LTC3400 to reenter sleep if the output load remains less than the sleep threshold. The frequency of this intermittent PWM or burst operation is proportional to load current; that is, as the load current drops further below the burst threshold, the LTC3400 turns on less frequently. When the load current increases above the

## OPERATION

burst threshold, the LTC3400 will resume continuous PWM operation seamlessly. Referring to the Block Diagram, an optional capacitor ( $C_{FF}$ ) between  $V_{OUT}$  and FB in some circumstances can reduce the peak-to-peak  $V_{OUT}$  ripple and input quiescent current during Burst Mode

operation. Typical values for  $C_{FF}$  range from 15pF to 220pF. The LTC3400B does not use Burst Mode operation and features continuous operation at light loads, eliminating low frequency output voltage ripple at the expense of light load efficiency.

## APPLICATIONS INFORMATION

### PCB LAYOUT GUIDELINES

The high speed operation of the LTC3400/LTC3400B demands careful attention to board layout. You will not get advertised performance with careless layout. Figure 2 shows the recommended component placement. A large ground pin copper area will help to lower the chip temperature. A multilayer board with a separate ground plane is ideal, but not absolutely necessary.

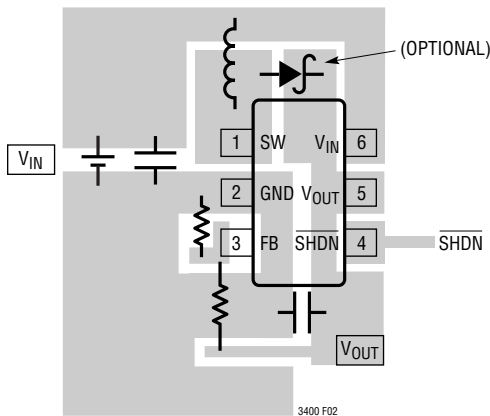

RECOMMENDED COMPONENT PLACEMENT. TRACES CARRYING HIGH CURRENT ARE DIRECT. TRACE AREA AT FB PIN IS SMALL. LEAD LENGTH TO BATTERY IS SHORT

Figure 2. Recommended Component Placement for Single Layer Board

### COMPONENT SELECTION

#### Inductor Selection

The LTC3400/LTC3400B can utilize small surface mount and chip inductors due to their fast 1.2MHz switching frequency. A minimum inductance value of 3.3 $\mu$ H is necessary for 3.6V and lower voltage applications and 4.7 $\mu$ H for output voltages greater than 3.6V. Larger values

of inductance will allow greater output current capability by reducing the inductor ripple current. Increasing the inductance above 10 $\mu$ H will increase size while providing little improvement in output current capability.

The approximate output current capability of the LTC3400/LTC3400B versus inductance value is given in the equation below and illustrated graphically in Figure 3.

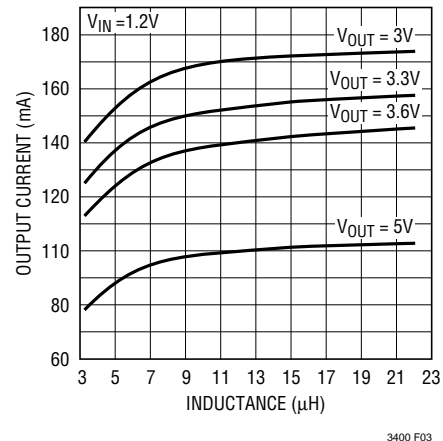

Figure 3. Maximum Output Current vs Inductance Based On 90% Efficiency

$$I_{OUT(MAX)} = \eta \cdot \left( I_P - \frac{V_{IN} \cdot D}{f \cdot L \cdot 2} \right) \cdot (1 - D)$$

where:

$\eta$  = estimated efficiency

$I_P$  = peak current limit value (0.6A)

$V_{IN}$  = input (battery) voltage

$D$  = steady-state duty ratio =  $(V_{OUT} - V_{IN})/V_{OUT}$

$f$  = switching frequency (1.2MHz typical)

$L$  = inductance value

## APPLICATIONS INFORMATION

The inductor current ripple is typically set for 20% to 40% of the maximum inductor current ( $I_P$ ). High frequency ferrite core inductor materials reduce frequency dependent power losses compared to cheaper powdered iron types, improving efficiency. The inductor should have low ESR (series resistance of the windings) to reduce the  $I^2R$  power losses, and must be able to handle the peak inductor current without saturating. Molded chokes and some chip inductors usually do not have enough core to support the peak inductor currents of 850mA seen on the LTC3400/LTC3400B. To minimize radiated noise, use a toroid, pot core or shielded bobbin inductor. See Table 1 for some suggested components and suppliers.

**Table 1. Recommended Inductors**

PART	L ( $\mu$ H)	MAX DCR m $\Omega$	HEIGHT (mm)	VENDOR
CDRH5D18-4R1	4.1	57	2.0	Sumida (847) 956-0666 www.sumida.com
CDRH5D18-100	10	124	2.0	
CDRH3D16-4R7	4.7	105	1.8	
CDRH3D16-6R8		170	1.8	
CR43-4R7	4.7	109	3.5	
CR43-100	10	182	3.5	
CMD4D06-4R7MC	4.7	216	0.8	
CMD4D06-3R3MC	3.3	174	0.8	
DS1608-472	4.7	60	2.9	Coilcraft (847) 639-6400 www.coilcraft.com
DS1608-103	10	75	2.9	
DO1608C-472	4.7	90	2.9	
D52LC-4R7M	4.7	84	2.0	Toko (408) 432-8282 www.tokoam.com
D52LC-100M	10	137	2.0	
LQH3C4R7M24	4.7	195	2.2	Murata www.murata.com

### Output and Input Capacitor Selection

Low ESR (equivalent series resistance) capacitors should be used to minimize the output voltage ripple. Multilayer ceramic capacitors are an excellent choice as they have

extremely low ESR and are available in small footprints. A 2.2 $\mu$ F to 10 $\mu$ F output capacitor is sufficient for most applications. Larger values up to 22 $\mu$ F may be used to obtain extremely low output voltage ripple and improve transient response. An additional phase lead capacitor may be required with output capacitors larger than 10 $\mu$ F to maintain acceptable phase margin. X5R and X7R dielectric materials are preferred for their ability to maintain capacitance over wide voltage and temperature ranges.

Low ESR input capacitors reduce input switching noise and reduce the peak current drawn from the battery. It follows that ceramic capacitors are also a good choice for input decoupling and should be located as close as possible to the device. A 4.7 $\mu$ F input capacitor is sufficient for virtually any application. Larger values may be used without limitations. Table 2 shows a list of several ceramic capacitor manufacturers. Consult the manufacturers directly for detailed information on their entire selection of ceramic parts.

**Table 2. Capacitor Vendor Information**

SUPPLIER	PHONE	WEBSITE
AVX	(803) 448-9411	www.avxcorp.com
Murata	(714) 852-2001	www.murata.com
Taiyo Yuden	(408) 573-4150	www.t-yuden.com

### Output Diode

Use a Schottky diode such as an MBR0520L, PMEG2010EA, 1N5817 or equivalent if the converter output voltage is 4.5V or greater. The Schottky diode carries the output current for the time it takes for the synchronous rectifier to turn on. Do not use ordinary rectifier diodes, since the slow recovery times will compromise efficiency. A Schottky diode is optional for output voltages below 4.5V, but will increase converter efficiency by 2% to 3%.

## TYPICAL APPLICATIONS

Single Cell to 3.3V Synchronous Boost Converter  
with Load Disconnect in Shutdown

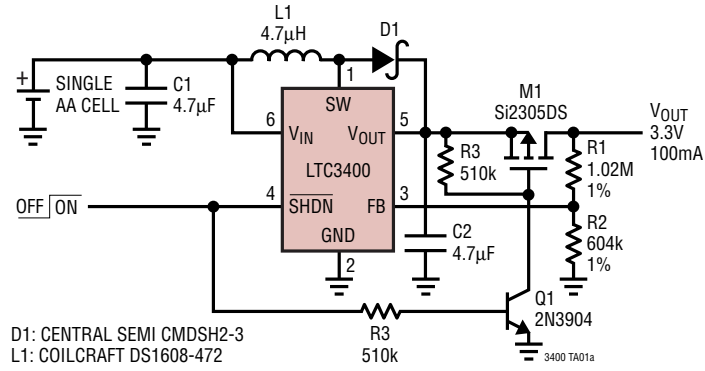

# TYPICAL APPLICATIONS

### Single Lithium Cell to 5V, 250mA

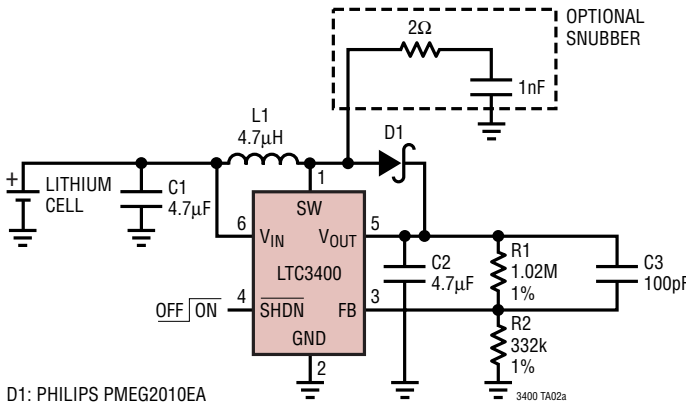

D1: PHILIPS PMEG2010EA  
L1: SUMIDA CMD4D06-4R7  
C1, C2: TAIYO YUDEN JMK212BJ475MG

### 3.6V to 5V Efficiency

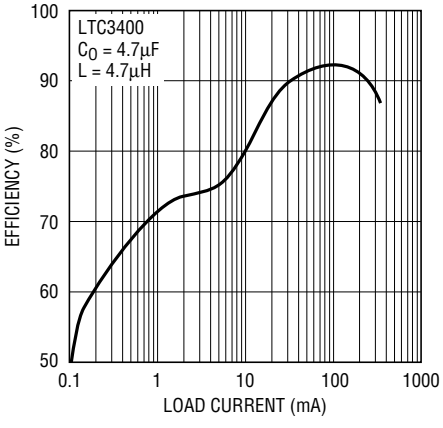

3400 TA02b

## TYPICAL APPLICATIONS

Single Cell AA Cell to  $\pm 3V$  Synchronous Boost Converter

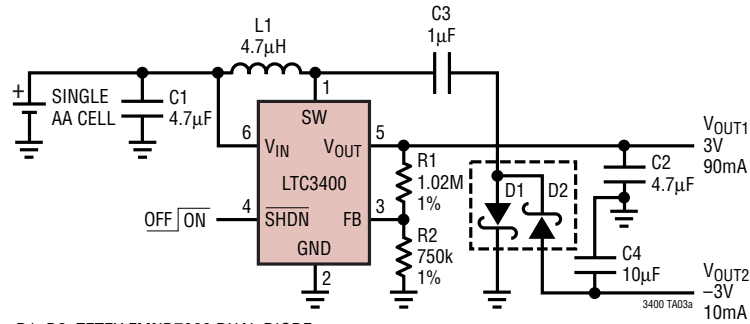

D1, D2: ZETEX FMND7000 DUAL DIODE  
 L1: COILCRAFT DS1608-472

# PACKAGE DESCRIPTION

**S6 Package**  
**6-Lead Plastic TSOT-23**  
 (Reference LTC DWG # 05-08-1636)

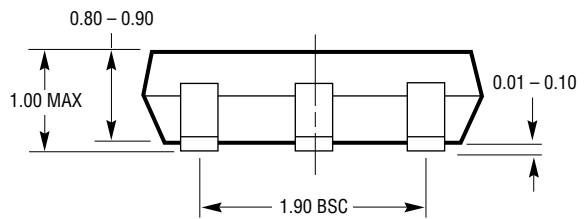
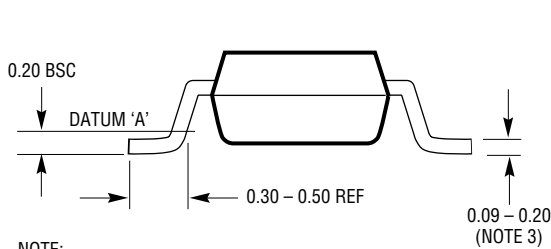
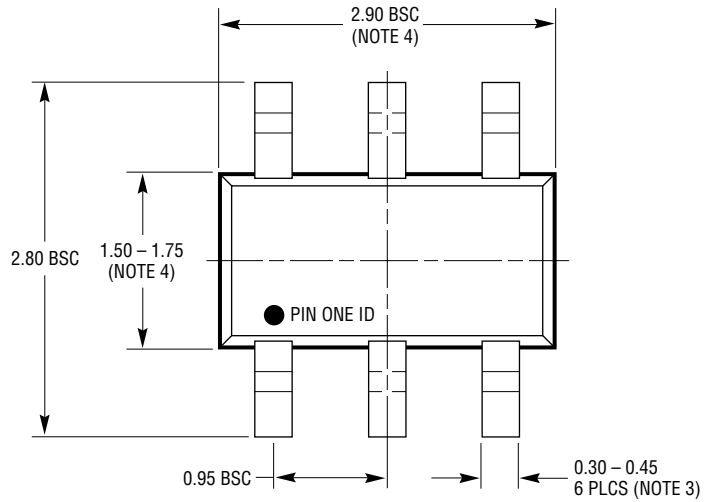
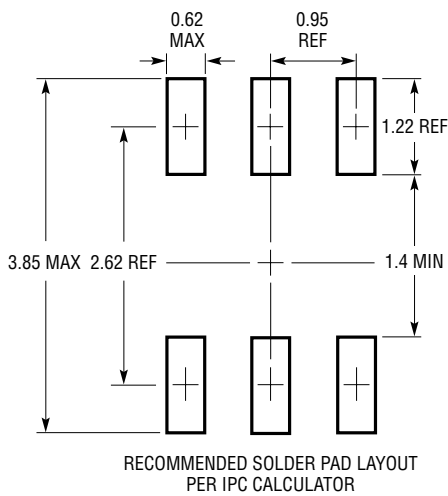

S6 TSOT-23 0302

- NOTE:
1. DIMENSIONS ARE IN MILLIMETERS
  2. DRAWING NOT TO SCALE
  3. DIMENSIONS ARE INCLUSIVE OF PLATING
  4. DIMENSIONS ARE EXCLUSIVE OF MOLD FLASH AND METAL BURR
  5. MOLD FLASH SHALL NOT EXCEED 0.254mm
  6. JEDEC PACKAGE REFERENCE IS MO-193

## TYPICAL APPLICATION

Single AA Cell to 2.5V Synchronous Boost Converter

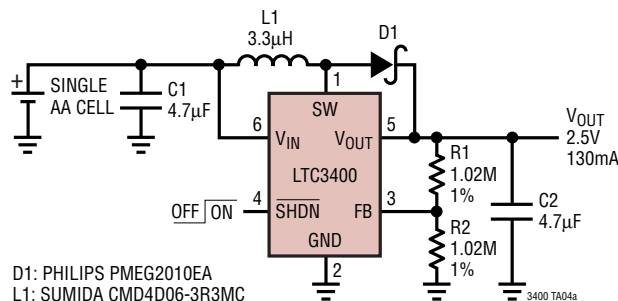

## RELATED PARTS

PART NUMBER	DESCRIPTION	COMMENTS
LT1308A/LT1308B	High Current, Micropower, Single Cell 600kHz DC/DC Converter	5V at 1A with Single Li-Ion Cell, $V_{OUT}$ to 34V
LT1613	1.4MHz, Single Cell DC/DC Converter in ThinSOT	$V_{IN}$ as Low as 1.1V, 3V at 30mA from Single Cell
LT1615	Micropower Step-Up DC/DC Converter in ThinSOT	$I_Q = 20\mu A$ , 1µA Shutdown Current, $V_{IN}$ as Low as 1V
LT <sup>®</sup> 1618	1.4MHz Step-Up DC/DC Converter with Current Limit	1.5A Switch, 1.6V to 18V Input Range, Input or Output Current Limiting
LT1619	High Efficiency Boost DC/DC Controller	1A Gate Drive, 1.1V to 20V Input, Separate $V_{CC}$ for Gate Drive
LTC1872	ThinSOT Boost DC/DC Controller	50kHz, 2.5V to 9.8V Input
LT1930/LT1930A	1.2MHz/2.2MHz DC/DC Converters in ThinSOT	$V_{IN} = 2.6V$ to 16V, 5V at 450mA from 3.3V Input
LT1932	Constant Current Step-Up LED Driver	Drives Up to Eight White LEDs, ThinSOT Package
LT1946/LT1946A	1.2MHz/2.7MHz Boost DC/DC Converters	1.5A, 36V Internal Switch, 8-Pin MSOP Package
LT1949	600kHz, 1A Switch PWM DC/DC Converter	1A, 0.5Ω, 30V Internal Switch, $V_{IN}$ as Low as 1.5V, Low-Battery Detect Active in Shutdown
LTC3401	1A, 3MHz Micropower Synchronous Boost Converter	1A Switch, Programmable Frequency, 10-Pin MSOP Package
LTC3402	2A, 3MHz Micropower Synchronous Boost Converter	2A Switch, Programmable Frequency, 10-Pin MSOP Package
LTC3423	1A, 3MHz Micropower Synchronous Boost Converter	1A Switch, Separate Bias Pin for Low Output Voltages
LTC3424	2A, 3MHz Micropower Synchronous Boost Converter	2A Switch, Separate Bias Pin for Low Output Voltages
LTC3425	5A, 8MHz, 4-Phase Micropower Synchronous Boost Converter	Up to 95% Efficiency, 5A Switch, $V_{IN}$ : 0.5V to 4.5V, $V_{OUT}$ (min): 2.4V to 5.25V, $I_Q = 12\mu A$ , QFN

## Looking for pricing, stock, or lifecycle information?

Click below to explore more details on WIN SOURCE:

 [View LTC3400BES6#TR on WIN SOURCE](#)

 [Linear Technology](#) Information

## Optimize Your Supply Chain with WIN SOURCE Solutions

-  Global Sourcing Solution
-  Obsolete Management
-  Cost Control Management
-  Shortage Management
-  Alternative Solution
-  Excess Inventory Management