



**THE DATASHEET OF
LTC3458LEDE#PBF**



1.7A, 1.5MHz Synchronous Step-Up DC/DC Converter with Output Disconnect

FEATURES

- **High Efficiency: Up to 95%**
- **Inrush Current Limiting and Output Disconnect**
- **Programmable Output Voltages up to 6V**
- **1.5V to 6V Input Range**
- Programmable/Synchronizable Fixed Frequency Operation up to 1.5MHz
- Programmable Automatic Burst Mode[®] Operation
- Current Mode Control with Programmable Soft-Start Period and Peak Current Limit
- 0.2Ω N-Channel and 0.3Ω P-Channel Switches
- Ultralow Quiescent Currents: 12μA Sleep, <1μA in Shutdown
- 12-Pin 4mm × 3mm Thermally Enhanced DFN Package

APPLICATIONS

- Point-of-Load Regulators
- USB V_{BUS} Power
- Portable GPS
- MP3 Players

DESCRIPTION

The LTC[®]3458L is a high efficiency, current mode, fixed frequency, step up DC/DC converter with true output disconnect and inrush current limiting. The LTC3458L is rated for up to 6V output and includes a 0.2Ω N-channel MOSFET switch and a 0.3Ω P-channel MOSFET synchronous rectifier. The LTC3458L is well suited for battery powered applications and includes programmable output voltage, switching frequency and loop compensation. The oscillator frequency can be set up to 1.5MHz or synchronized to an external clock.

Quiescent current is only 12μA during Burst Mode operation maximizing battery life in portable applications. The Burst Mode current threshold, peak current limit, and soft-start are externally programmable. Other features include <1μA shutdown current, antiringing control, and thermal limit. The LTC3458L is available in a low profile (0.75mm), 4mm × 3mm 12-pin DFN package.

LT, LT, LTC and LTM are registered trademarks of Linear Technology Corporation. All other trademarks are the property of their respective owners. Burst Mode is a registered trademark of Linear Technology Corporation. Protected by U.S. Patents including 5481178, 6580258, 6304066, 6127815, 6498466, 6611131.

TYPICAL APPLICATION

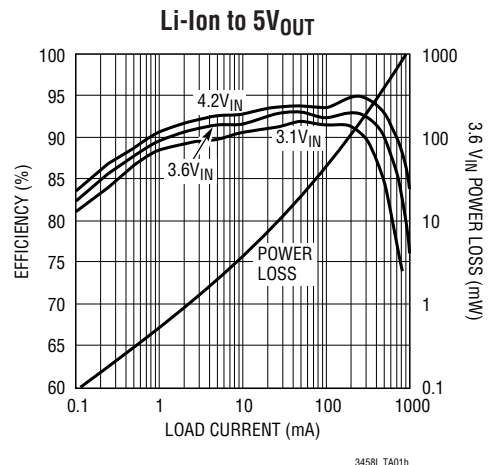
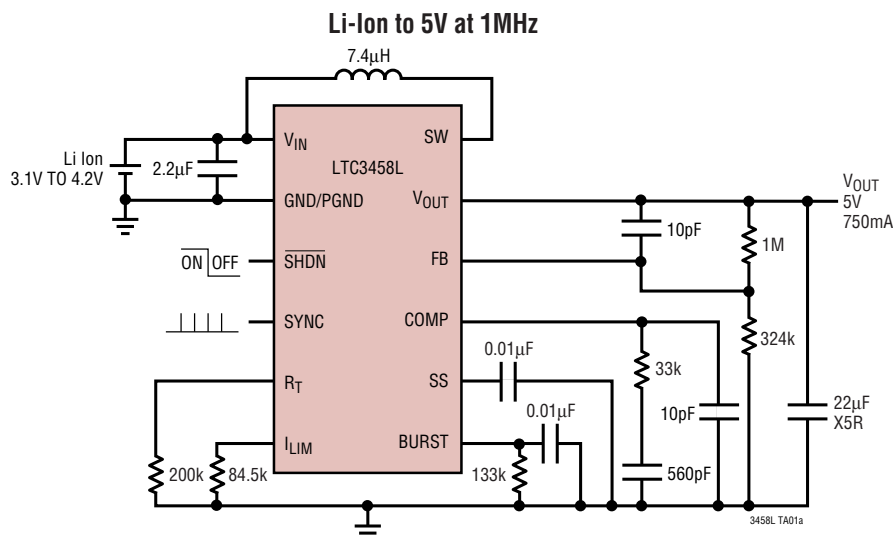

ABSOLUTE MAXIMUM RATINGS

(Note 1)

V_{IN} , SS, SYNC Voltages	-0.3 to 7V
BURST, SHDN, V_{OUT} Voltages	-0.3 to 7V
Operating Temperature Range	
(Notes 2, 3)	-40°C to 85°C
Storage Temperature Range	-65°C to 125°C
SW Voltage	
DC	-0.3V to 7V
Pulsed <100ns	-0.3V to 8V

PIN CONFIGURATION

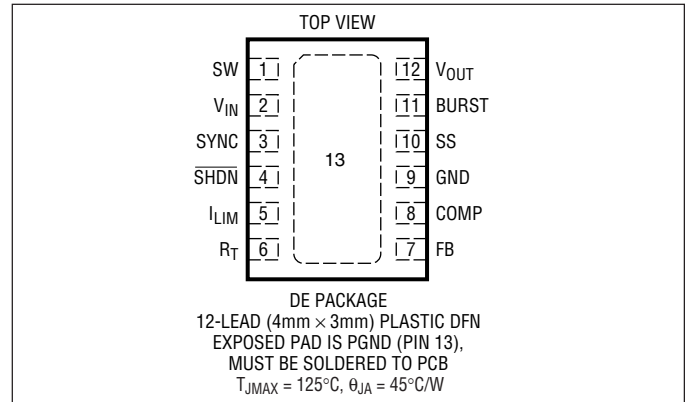

ORDER INFORMATION

LEAD FREE FINISH	TAPE AND REEL	PART MARKING	PACKAGE DESCRIPTION	TEMPERATURE RANGE
LTC3458LEDE#PBF	LTC3458LEDE#TRPBF	3458L	12-Lead (4mm x 3mm) Plastic DFN	-40°C to 85°C

Consult LTC Marketing for parts specified with wider operating temperature ranges.
Consult LTC for information on nonstandard lead based finish parts.

For more information on lead free part marking, go to: <http://www.linear.com/leadfree/>
For more information on tape and reel specifications, go to: <http://www.linear.com/tapeandreel/>

ELECTRICAL CHARACTERISTICS

The ● denotes the specifications which apply over the full operating temperature range, otherwise specifications are at $T_A = 25^\circ\text{C}$, $V_{IN} = 3.3\text{V}$, $V_{OUT} = 5\text{V}$, $R_T = 200\text{k}$, unless otherwise noted.

PARAMETER	CONDITIONS	MIN	TYP	MAX	UNITS	
Minimum V_{IN} Operating Voltage	$T_A = 0^\circ\text{C}$ to 85°C		1.4	1.5	V	
	$T_A = -40^\circ\text{C}$ to 0°C		1.4	1.7	V	
Output Voltage Adjust Range		● 2		6	V	
Feedback Voltage	0°C to 85°C , $V_{OUT} = 3.3\text{V}$	1.21	1.225	1.25	V	
	-40°C to 0°C	1.20		1.25	V	
Undervoltage (Exit Burst Mode Operation)	Below Feedback Voltage		-4		%	
Feedback Input Current	$V_{FB} = 1.23\text{V}$		1	50	nA	
Quiescent Current – Burst Mode Operation	V_{IN} Current at 3.3V		12	30	μA	
	V_{OUT} Current at 5V		5	10	μA	
Quiescent Current – Shutdown	V_{IN} Current at 3.3V		0.5	1	μA	
	V_{OUT} Current at 0V		1	3	μA	
Quiescent Current – Active	V_{IN} Current Switching		1	3	mA	
NMOS Switch Leakage		●	0.05	5	μA	
PMOS Switch Leakage		●	0.05	5	μA	
NMOS Switch On Resistance	$V_{OUT} = 5\text{V}$		0.2		Ω	
PMOS Switch On Resistance	$V_{OUT} = 5\text{V}$		0.3		Ω	
Fixed NMOS Current Limit	$R_{ILIM} = 84.5\text{k}$	●	1.7	2.1	A	
Maximum Duty Cycle	$V_{IN} = 3.3\text{V}$, $f_{OSC} = 1\text{MHz}$	●	80	90	%	
Minimum Duty Cycle		●		0	%	
Frequency Accuracy	$R_T = 200\text{k}$	●	0.85	1	1.15	MHz
Error Amplifier Transconductance			60		$\mu\text{A/V}$	
Error Amplifier Source Current			7		μA	

3458Ifa

ELECTRICAL CHARACTERISTICS

The ● denotes the specifications which apply over the full operating temperature range, otherwise specifications are at $T_A = 25^\circ\text{C}$, $V_{IN} = 3.3\text{V}$, $V_{OUT} = 5\text{V}$, $R_T = 200\text{k}$, unless otherwise noted.

PARAMETER	CONDITIONS	MIN	TYP	MAX	UNITS
Error Amplifier Sink Current			7		μA
SYNC Input High		● 1.5			V
SYNC Input Low		●		0.35	V
SHDN Input High		● 1.25			V
SHDN Input Low		●		0.3	V
BURST Mode Peak Current ($I_{BURSTPEAK}$)	$R_{ILIM} = 84.5\text{k}$		0.55		A
BURST Threshold Voltage			1.10		V

Note 1: Stresses beyond those listed under Absolute Maximum Ratings may cause permanent damage to the device. Exposure to any Absolute Maximum Rating condition for extended periods may affect device reliability and lifetime.

Note 2: This IC includes overtemperature protection that is intended to protect the device during momentary overload conditions. Junction temperature will exceed 125°C when overtemperature protection is active.

Continuous operation above the specified maximum operating junction temperature may impair device reliability.

Note 3: The LTC3458LE is guaranteed to meet performance specifications from 0°C to 70°C . Specifications over the -40°C to 85°C operating temperature range are assured by design, characterization and correlation with statistical process controls.

TYPICAL PERFORMANCE CHARACTERISTICS ($T_A = 25^\circ\text{C}$ unless otherwise specified)

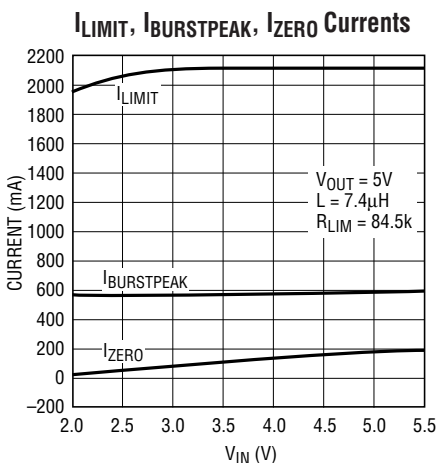

3458L G01

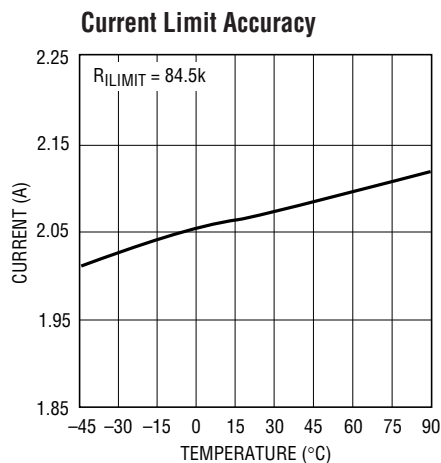

3458L G02

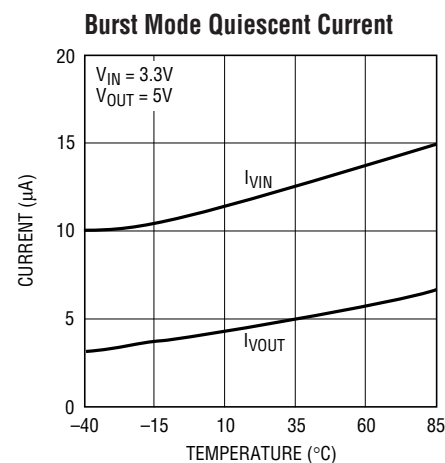

3458L G03

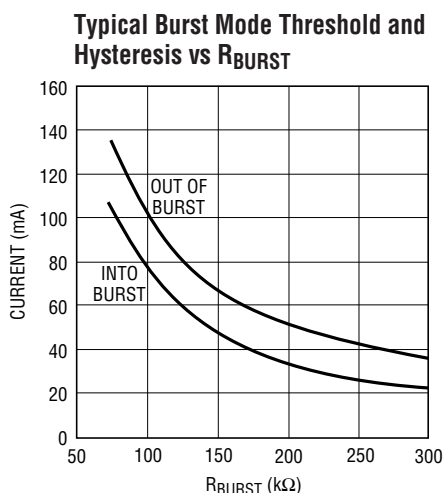

3458L G04

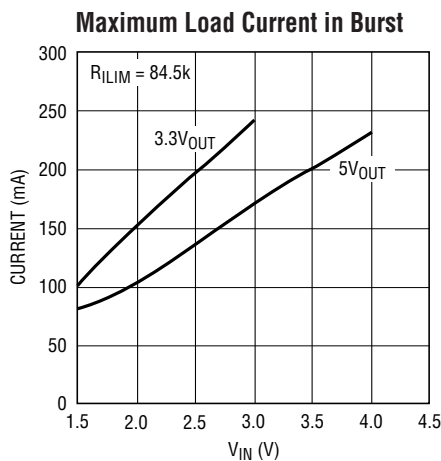

3458L G05

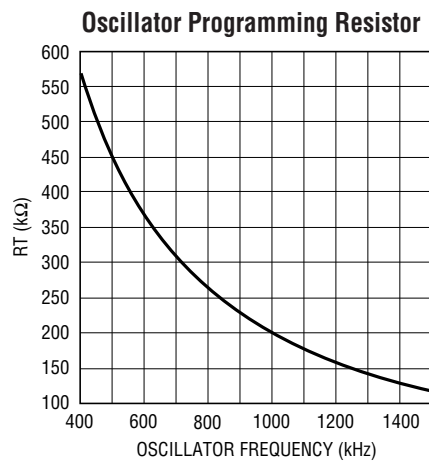

3458L G06

3458Lfa

TYPICAL PERFORMANCE CHARACTERISTICS ($T_A = 25^\circ\text{C}$ unless otherwise specified)

Frequency Accuracy

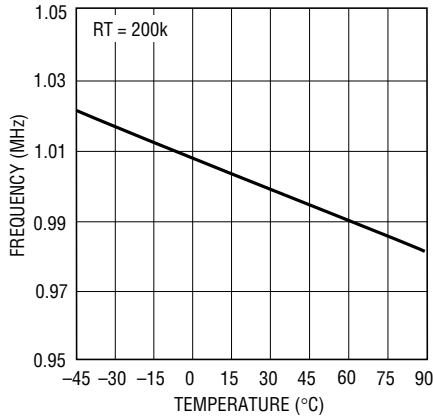

3458L G07

Efficiency vs Frequency

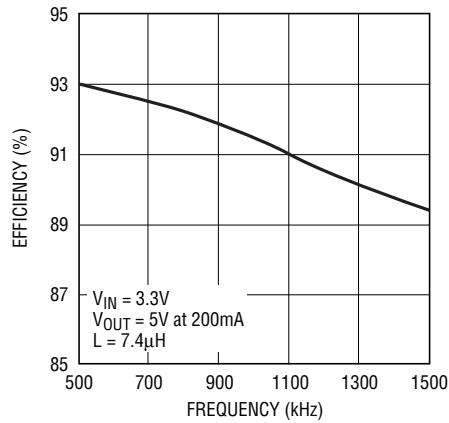

3458L G08

N-Channel and P-Channel $R_{DS(ON)}$

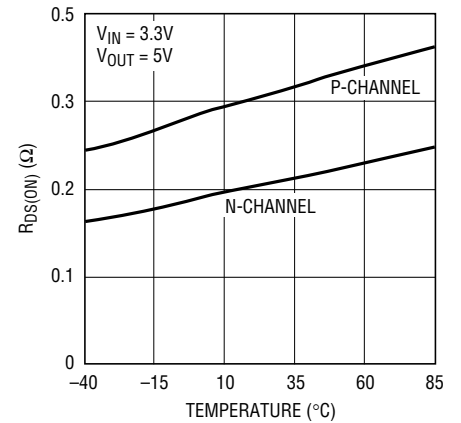

3458L G09

Maximum Load Current

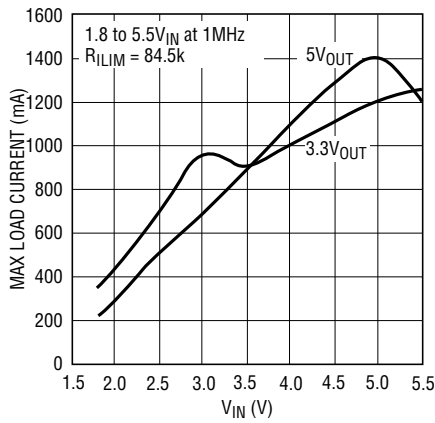

3458L G10

SHDN Pin Threshold and Hysteresis

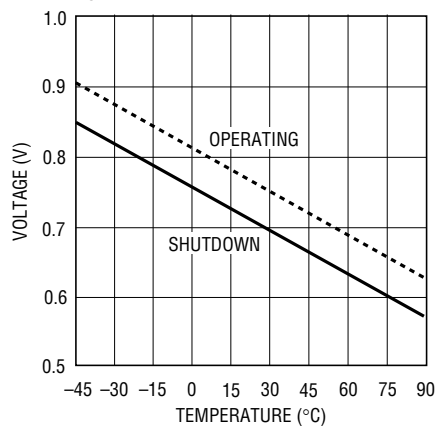

3458L G11

SYNC Pin Threshold

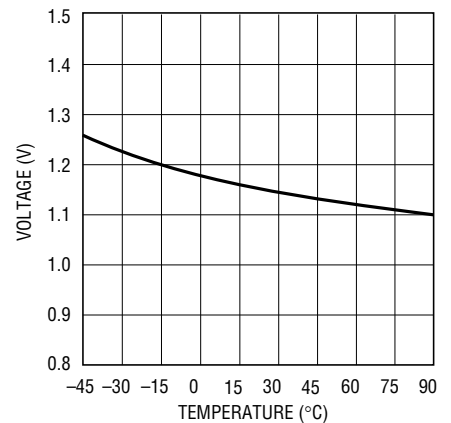

3458L G12

FB Voltage

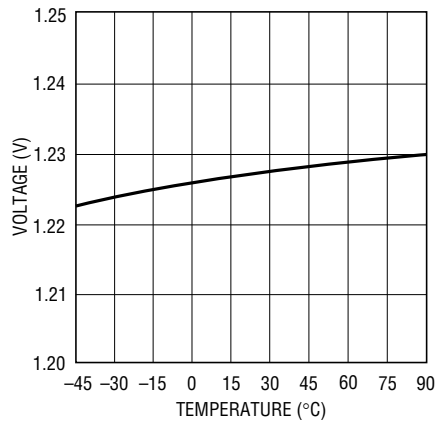

3458L G13

TYPICAL PERFORMANCE CHARACTERISTICS ($T_A = 25^\circ\text{C}$ unless otherwise specified)

**Fixed Frequency (FF)
Discontinuous Current**

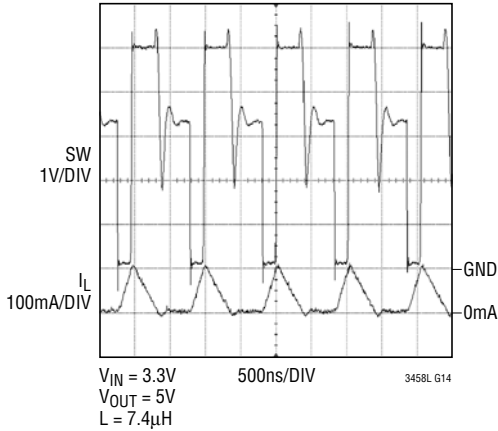

**Fixed Frequency (FF)
Continuous Current**

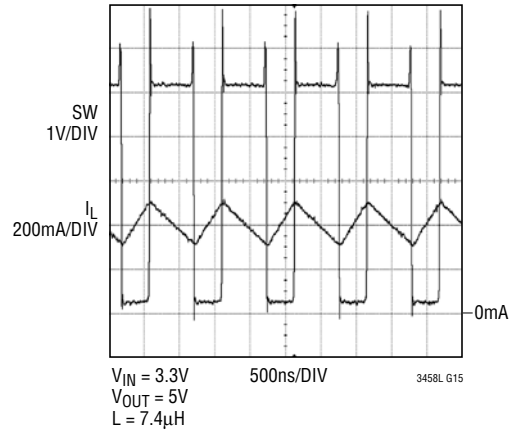

Over-Current with 2A I_{LIMIT}

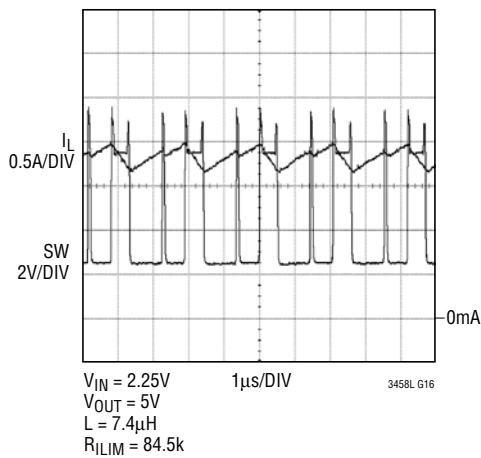

Burst Mode Operation

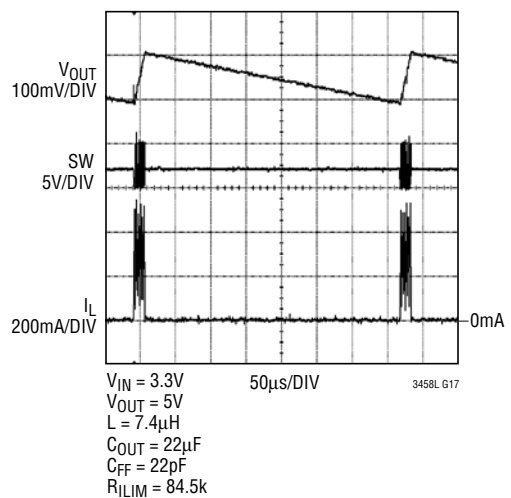

Burst Mode Operation Close-Up

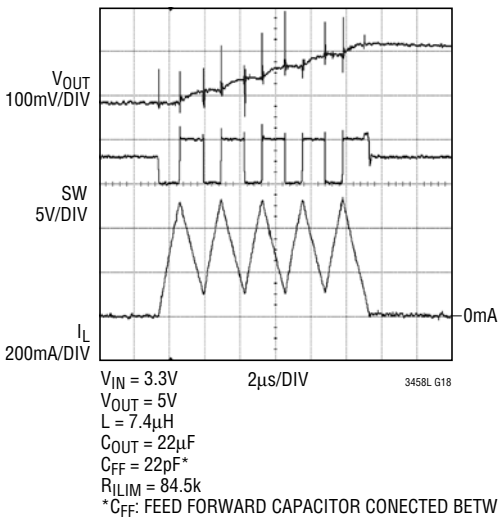

Soft-Start into 20Ω Load

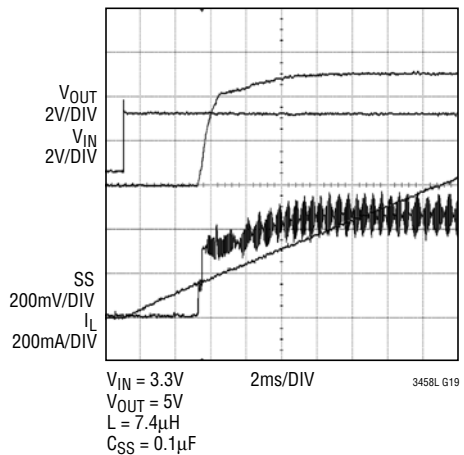

TYPICAL PERFORMANCE CHARACTERISTICS (T_A = 25°C unless otherwise specified)

Sync Operation at 1.33MHz

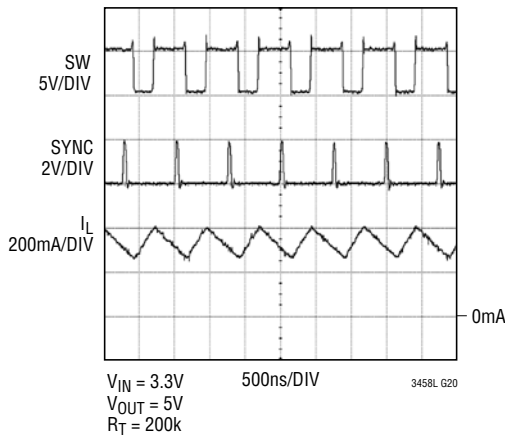

FF Mode 100-300mA Load Step

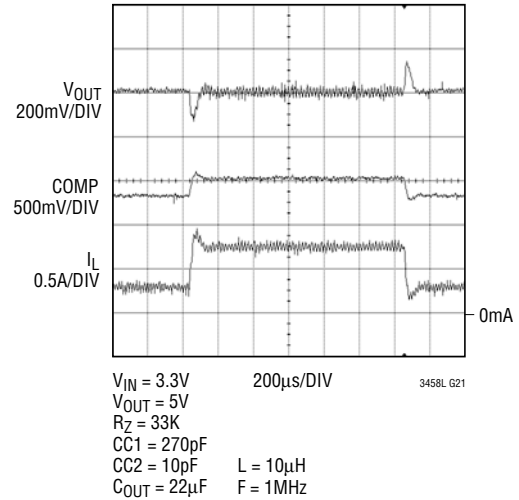

Burst Mode Operation 10mA to 50mA Load Step

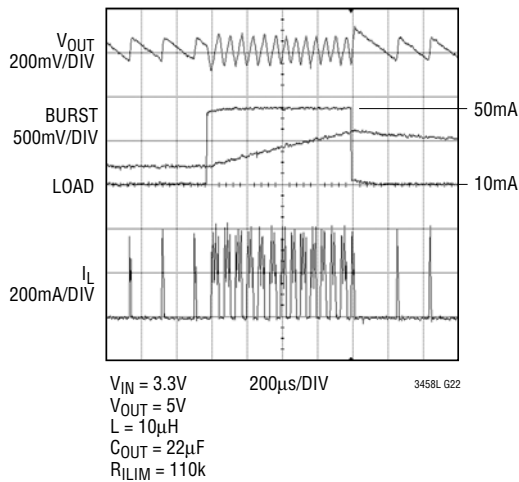

Auto Mode 10mA to 100mA Load Step

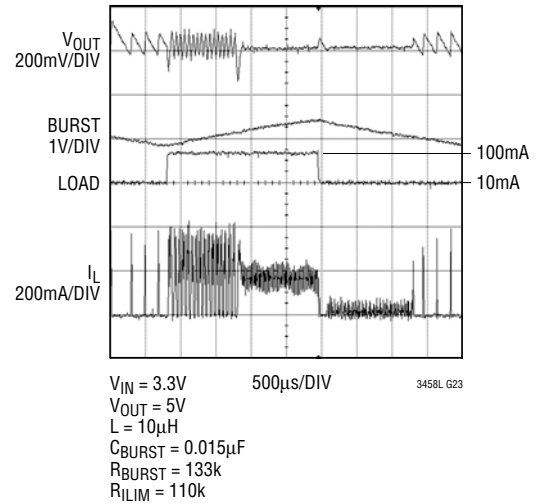

10mA to 200mA Load Step Showing UV Trip

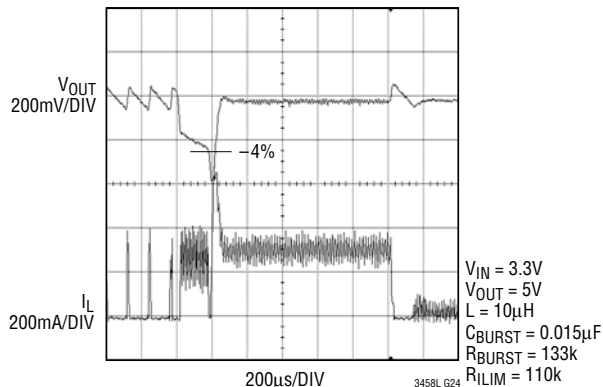

Forced BURST to FF Mode Switch with 50mA Load

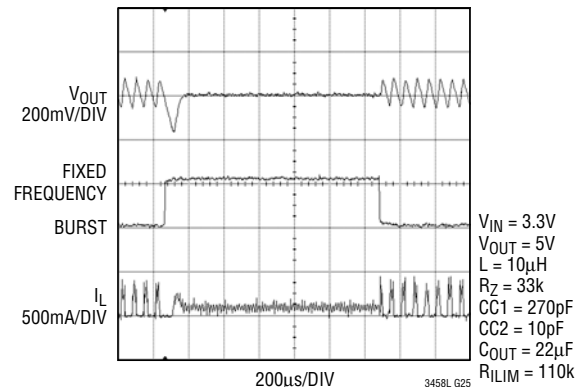

PIN FUNCTIONS

SW (Pin 1): Switch Pin for Inductor Connection. During discontinuous conduction mode an antiring resistor connects SW to V_{IN} to reduce noise.

V_{IN} (Pin 2): Input Supply Pin. Connect this to the input supply and decouple with 1 μ F minimum.

SYNC (Pin 3): Oscillator Synchronization Pin. A clock pulse width of 100ns to 2 μ s is required to synchronize the internal oscillator. This pin is disabled when grounded.

SHDN (Pin 4): Shutdown Pin. Grounding this pin shuts down the IC. Connect to >1.25V to enable.

I_{LIM} (Pin 5): Adjustable Peak Current Limit. Connect a resistor from I_{LIM} to GND to program the peak inductor current according to the following formula:

$$I_{LIMIT} = \frac{180}{R_{ILIM}}$$

where I_{LIMIT} is in amps and R_{ILIM} is in k Ω .

R_T (Pin 6): Connect a resistor to ground to program the oscillator frequency, according to the formula:

$$f_{OSC} = \frac{1}{0.2 + 0.004 \cdot R_T}$$

where f_{OSC} is in MHz and R_T is in k Ω .

Oscillator frequency can be programmed between 400kHz and 1.5MHz.

FB (Pin 7): Connect Resistor Divider Tap Here. The output voltage can be adjusted from 2V to 6V. Feedback reference voltage is typically 1.225V.

COMP (Pin 8): g_m Error Amp Output. A frequency compensation network is connected from this pin to ground to

compensate the loop. See the section “Compensating the Feedback Loop” for guidelines.

GND (Pin 9): Signal Ground Pin.

SS (Pin 10): Connect a capacitor between this pin and ground to set soft-start period. 5 μ A of current is sourced from SS during soft-start.

$$t(\text{msec}) = C_{SS} (\mu\text{F}) \cdot 200$$

BURST (Pin 11): Burst Mode Threshold Adjust Pin. A resistor/capacitor combination from this pin to ground programs the average load current at which automatic Burst Mode operation is entered, according to the formula:

$$R_{BURST} = \frac{10}{I_{BURST}}$$

where R_{BURST} is in k Ω and I_{BURST} is in amps.

$$C_{BURST} = \frac{C_{OUT} \cdot V_{OUT}}{10,000}$$

where $C_{BURST(MIN)}$ and C_{OUT} are in μ F.

To force fixed frequency PWM mode, connect BURST to V_{OUT} through a 51k resistor.

V_{OUT} (Pin 12): Output of the Synchronous Rectifier and Internal Gate Drive Source for the Power Switches.

$$V_{OUT} = 1.225 \left(1 + \frac{R1}{R2} \right)$$

Exposed Pad (PGND) (Pin 13): Must be soldered to PCB ground, for electrical contact and optimum thermal performance.

BLOCK DIAGRAM

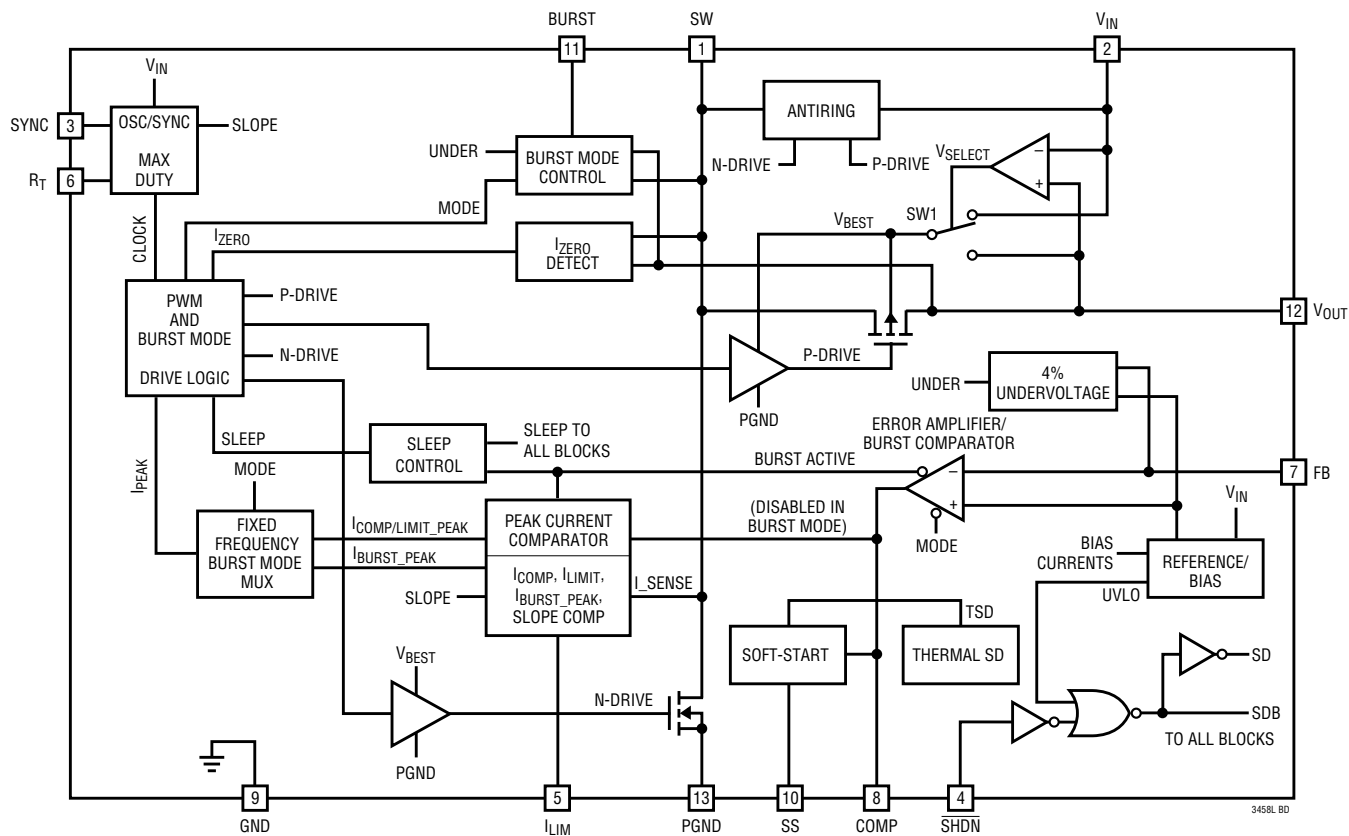

APPLICATIONS INFORMATION

Detailed Description

The LTC3458L provides high efficiency, low noise power for boost applications with output voltages up to 6V. The true output disconnect feature eliminates inrush current, and allows V_{OUT} to go to zero during shutdown. The current mode architecture with adaptive slope compensation provides ease of loop compensation with excellent transient load response. The low $R_{DS(ON)}$, low gate charge synchronous switches eliminate the need for an external Schottky rectifier, and provide efficient high frequency pulse width modulation (PWM) control. High efficiency is achieved at light loads when Burst Mode operation is entered, where the IC's quiescent current is a low 12 μ A typical on V_{IN} . The LTC3458L is designed to provide custom performance in a variety of applications with programmable feedback, current limit, oscillator frequency, soft-start, and Burst Mode threshold.

LTC3458L Programmable Functions

Current Limit (I_{LIMIT})/Peak Burst Current ($I_{BURSTPEAK}$). The programmable current limit circuit sets the maximum peak current in the internal N-channel MOSFET switch. This clamp level is programmed using a resistor to ground on I_{LIM} . In Burst Mode operation, the current limit is automatically set to $\sim 1/4$ of the programmed current limit for optimal efficiency. An 84.5k R_{ILIM} resistor is recommended in most applications unless a lower limit is needed to prevent the external inductor from saturating.

$$I_{LIMIT} = \frac{180}{R}$$

I is in amps and R is in k Ω .

$$I_{BURSTPEAK} \approx \frac{1}{4} \cdot I_{LIMIT}$$

APPLICATIONS INFORMATION

Error Amp. The error amplifier is a transconductance type, with its positive input internally connected to the 1.225V reference, and its negative input connected to FB. A simple compensation network is placed from COMP to ground. Internal clamps limit the minimum and maximum error amp output voltage for improved large signal transient response. During sleep (in Burst Mode), the compensation pin is high impedance, however clamps limit the voltage on the external compensation network, preventing the compensation capacitor from discharging to zero during the sleep time.

Oscillator. The frequency of operation is set through a resistor from R_T to ground. An internally trimmed timing capacitor resides inside the IC. The oscillator frequency is calculated using the following formula:

$$f_{osc} = \frac{1}{0.2 + 0.004 \cdot R_T}$$

where f_{osc} is in MHz and R_T is in $k\Omega$

The oscillator can be synchronized with an external clock applied to the SYNC pin. When synchronizing the oscillator, the free running frequency must be set to approximately 30% lower than the desired synchronized frequency.

Soft-Start. The soft-start time is programmed with an external capacitor to ground on SS. An internal current source charges it with a nominal 5 μ A. The voltage on the SS pin (in conjunction with the external resistor on I_{LIM}) is used to control the peak current limit until the voltage on the capacitor exceeds ~1V, at which point the external resistor sets the peak current. In the event of a commanded shutdown, severe short-circuit, or a thermal shutdown, the capacitor is discharged automatically.

$$t_{(msec)} = C_{SS} (\mu F) \cdot 200$$

Other LTC3458L Features and Functions

Antiringing Control. The antiringing control places a resistor across the inductor to damp the ringing on SW pin discontinuous conduction mode. The LC ringing (L = inductor, C_{SW} = Capacitance on SW pin) is low energy, but can cause EMI radiation.

Current Sensing. Lossless current sensing converts the peak current signal to a voltage to sum in with the internal slope compensation. This summed signal is compared to the error amplifier output to provide a peak current control command for the PWM. The slope compensation in the IC is adaptive to the input and output voltage, therefore the converter provides the proper amount of slope compensation to ensure stability, but not an excess to cause a loss of phase margin in the converter.

Output Disconnect and Inrush Limiting. The LTC3458L is designed to allow true output disconnect by eliminating body diode conduction of the internal P-channel MOSFET rectifier. This allows V_{OUT} to go to zero volts during shutdown, drawing no current from the input source. It also allows for inrush current limiting at turn-on, minimizing surge currents seen by the input supply. Note that to obtain the advantages of output disconnect, there must not be any external Schottky diodes connected between SW and V_{OUT} .

Shutdown. The part is shut down by pulling \overline{SHDN} below 0.3V, and made active by pulling the pin above 1.25V. Note that \overline{SHDN} can be driven above V_{IN} or V_{OUT} , as long as it is limited to less than 6V.

Synchronous Rectifier. To prevent the inductor current from running away, the P-channel MOSFET synchronous rectifier is only enabled when $V_{OUT} > (V_{IN} + 0.25V)$.

Thermal Shutdown. If the die temperature reaches approximately 150°C, the part will go into thermal shutdown and all switches will be turned off and the soft-start capacitor will be reset. The part will be enabled again when the die temperature has dropped by 10°C (nominal).

Zero Current Amplifier (I_{ZERO}). The zero current amplifier monitors the inductor current to the output and shuts off the synchronous rectifier once the current is below 50mA typical, preventing negative inductor current.

Burst Mode Operation

Burst Mode operation can be automatic or user controlled. In automatic operation, the IC will automatically enter Burst Mode operation at light load and return to fixed frequency PWM mode for heavier loads. The user can program the average load current at which the mode

APPLICATIONS INFORMATION

transition occurs using a single resistor. During Burst Mode operation, the oscillator is shut down, since the on time is determined by the time it takes the inductor current to reach a fixed peak current, and the off time is determined by the time it takes for the inductor current to return to zero.

In Burst Mode operation, the IC delivers energy to the output until it is regulated and then goes into a sleep mode where the outputs are off and the IC is consuming only 12µA of quiescent current. In this mode the output ripple voltage has a variable frequency component with load current and will be typically 2% peak-to-peak. This maximizes efficiency at very light loads by minimizing switching and quiescent losses. Burst Mode ripple can be reduced slightly by using more output capacitance (22µF or greater). This capacitor does not need to be a low ESR type if low ESR ceramics are also used. Another method of reducing Burst Mode ripple is to place a small feed-forward capacitor across the upper resistor in the V_{OUT} feedback divider network.

During Burst Mode operation, COMP is disconnected from the error amplifier in an effort to hold the voltage on the external compensation network where it was before entering Burst Mode operation. To minimize the effects of leakage current and stray resistance, voltage clamps limit the minimum and maximum voltage on COMP during Burst Mode operation. This minimizes the transient experienced when a heavy load is suddenly applied to the converter after being in Burst Mode operation for an extended period of time.

For automatic operation, an RC network should be connected from BURST to ground. The value of the resistor will control the average load current (I_{BURST}) at which Burst Mode operation will be entered and exited (there is hysteresis to prevent oscillation between modes). The equation given for the capacitor on BURST is for the minimum value, to prevent ripple on the BURST pin from causing the part to oscillate in and out of Burst Mode operation at the current where the mode transition occurs.

$$R_{BURST} = \frac{10}{I_{BURST}}$$

where R_{BURST} is in kΩ and I_{BURST} is in amps.

$$C_{BURST} = \frac{C_{OUT} \cdot V_{OUT}}{10,000}$$

where $C_{BURST(MIN)}$ and C_{OUT} are in µF.

Note: the BURST pin only sources current based on current delivered to V_{OUT} through the P-channel MOSFET. If current in the inductor is allowed to go negative (this can occur at very light loads and high step-up ratios), the burst threshold may become inaccurate, preventing the IC from entering Burst Mode operation. For R_{BURST} values greater than 200k, a larger than recommended inductor value may be needed to ensure positive inductor current and automatic Burst Mode operation.

In the event that a sudden load transient causes the voltage level on FB to drop by more than 4% from the regulation value, an internal pull-up is applied to BURST, forcing the part quickly out of Burst Mode operation. For optimum transient response when going between Burst Mode operation and PWM mode, Burst can be controlled manually by the host. This way PWM mode can be commanded before the load step occurs, minimizing output voltage drop. Note that Burst Mode operation is inhibited during start-up and soft-start.

Manual Control

For applications requiring fixed frequency operation at all load currents, connect the BURST pin to V_{OUT} through a 51k resistor. To force Burst Mode operation, ground the BURST pin.

For applications where a large load step can be anticipated, the circuit below can be used to reduce the voltage transient on V_{OUT} . Automatic operation is achieved when the external P-channel MOSFET is off and fixed frequency operation is commanded when the external P-channel MOSFET is on. In shutdown, the P-channel MOSFET should be off.

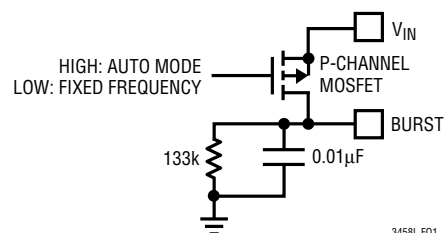

Figure 1

APPLICATIONS INFORMATION

COMPONENT SELECTION

Inductor Selection

The high frequency operation of the LTC3458L allows for the use of small surface mount inductors. Since the internal slope compensation circuit relies on the inductor's current slope and frequency, Table 1 should be used to select an inductor value for a given frequency of operation ($\pm 25\%$). The recommended value will yield optimal transient performance while maintaining stable operation. Inductor values larger than listed in Table 1 are permissible to reduce the current ripple.

Table 1. Recommended Inductor Values

Frequency	Inductor Value(μH)
1.5MHz	3.3 to 4.7
1.25MHz	4.7 to 6.8
1MHz	6.8 to 10
750kHz	10 to 15
500kHz	15 to 22

For high efficiency, choose an inductor with high frequency core material, such as ferrite, to reduce core losses. The inductor should have low ESR (equivalent series resistance) to reduce the I^2R losses, and must be able to handle the peak inductor current without saturating. Molded chokes or chip inductors usually do not have enough core to support peak inductor currents in the 1A to 3A region. To minimize radiated noise, use a toroidal or shielded inductor. (Note that the inductance of shielded types will drop more as current increases, and will saturate more easily). See Table 2 for a list of inductor manufacturers.

Table 2. Inductor Vendor Information

Supplier	Phone	Website
Coilcraft	(847) 639-6400	www.coilcraft.com
TDK	(847) 803-6100	www.component.tdk.com
Murata	USA: (814) 237-1431 (800) 831-9172	www.murata.com
Sumida	USA: (847) 956-0666 Japan: 81-3-3607-5111	www.japanlink.com/sumida
COEV	(800) 227-7040	www.coev.net
Toko	(847) 297-0070	www.tokoam.com
Würth	(202) 785-8800	www.we-online.com

Some example inductor part types are:

Coilcraft: MSS7341 and MSS5131 Series
 TDK: RLF5018T and SLF7045 Series
 Murata: LQH4C and LQN6C Series
 Sumida: CDRH4D28 and CDRH6D28 Series
 COEV: DQ7545 Series
 TOKO: D62CB and D63LCB Series
 WÜRTH: WE-PD2 Series

Output Capacitor Selection

The output voltage ripple has three components to it. The bulk value of the capacitor is set to reduce the ripple due to charge into the capacitor each cycle. The max ripple due to charge is given by:

$$V_{\text{RBULK}} = \frac{I_{\text{P}} \cdot V_{\text{IN}}}{C_{\text{OUT}} \cdot V_{\text{OUT}} \cdot f}$$

where I_{P} = peak inductor current and f = switching frequency.

The ESR (equivalent series resistance) is usually the most dominant factor for ripple in most power converters. The ripple due to capacitor ESR is given by:

$$V_{\text{RCESR}} = I_{\text{P}} \cdot C_{\text{ESR}}$$

where C_{ESR} = Capacitor Series Resistance.

The ESL (equivalent series inductance) is also an important factor for high frequency converters. Using small, surface mount ceramic capacitors, placed as close as possible to the V_{OUT} pins, will minimize ESL.

Low ESR/ESL capacitors should be used to minimize output voltage ripple. For surface mount applications, AVX TPS Series tantalum capacitors, Sanyo POSCAP, or Taiyo Yuden X5R type ceramic capacitors are recommended. For through-hole applications, Sanyo OS-CON capacitors offer low ESR in a small package size.

In all applications, a minimum of $4.7\mu\text{F}$ (generally $22\mu\text{F}$ is recommended), low ESR ceramic capacitor should be placed as close to the V_{OUT} pin as possible, and grounded to a local ground plane.

APPLICATIONS INFORMATION

Input Capacitor Selection

The input filter capacitor reduces peak currents drawn from the input source and reduces input switching noise. In most applications >1 μ F per amp of peak input current is recommended. See Table 3 for a list of capacitor manufacturers for input and output capacitor selection.

Table 3. Capacitor Vendor Information

Supplier	Phone	Website
AVX	(803) 448 - 9411	www.avxcorp.com
Sanyo	(619) 661 - 6322	www.sanyovideo.com
TDK	(847) 803 - 6100	www.component.tdk.com
Murata	USA: (814) 237-1431 (800) 831-9172	www.murata.com
Taiyo Yuden	(408) 573 - 4150	www.t-yuden.com

Operating Frequency Selection

There are several considerations in selecting the operating frequency of the converter. The first is staying clear of sensitive frequency bands, which cannot tolerate any spectral noise. For example in products incorporating RF communications the 455kHz IF frequency is sensitive to any noise, therefore switching above 600kHz is desired. Some communications have sensitivity to 1.1MHz and in that case a 1.5MHz switching converter frequency may be employed. The second consideration is the physical size of the converter. As the operating frequency goes up, the inductor and filter capacitors go down in value and size. The trade off is in efficiency, since the switching losses due to gate charge increase proportional with frequency.

Thermal Considerations

For the LTC3458L to deliver its full output power, it is imperative that a good thermal path be provided to dissipate the heat generated within the package. This can be accomplished by taking advantage of the large thermal pad on the underside of the IC. It is recommended that multiple vias in the printed circuit board be used to conduct heat away from the IC and into a copper plane with as much area as possible. If the junction temperature rises above ~150°C, the part will go into thermal shutdown, and all switching will stop until the temperature drops.

Compensating the Feedback Loop

The LTC3458L uses current mode control, with internal adaptive slope compensation. Current mode control eliminates the 2nd order filter due to the inductor and output capacitor exhibited in voltage mode controllers, and simplifies the power loop to a single pole filter response. The product of the modulator control to output DC gain, and the error amp open-loop gain gives the DC gain of the system:

$$G_{DC} = G_{CONTROL} \cdot G_{EA} \cdot \frac{V_{REF}}{V_{OUT}} \cdot G_{CURRENT_SENSE}$$

$$G_{CONTROL} = \frac{2 \cdot V_{IN}}{I_{OUT}}$$

$$G_{EA} \approx 1,000 \quad G_{CURRENT_SENSE} = \frac{1}{R_{DS(ON)}}$$

The output filter pole is given by:

$$f_{FILTER_POLE} = \frac{I_{OUT}}{\pi \cdot V_{OUT} \cdot C_{OUT}}$$

where C_{OUT} is the output filter capacitor.

The output filter zero is given by:

$$f_{FILTER_ZERO} = \frac{1}{2\pi \cdot R_{ESR} \cdot C_{OUT}}$$

where R_{ESR} is the output capacitor equivalent series resistance.

A troublesome feature of the boost regulator topology is the right half plane zero (RHP), and is given by:

$$f_{RHPZ} = \frac{V_{IN}^2}{2\pi \cdot I_{OUT} \cdot V_{OUT} \cdot L}$$

At heavy loads this gain increase with phase lag can occur at a relatively low frequency. The loop gain is typically rolled off before the RHP zero frequency.

APPLICATIONS INFORMATION

The typical error amp compensation is shown in Figure 2. The equations for the loop dynamics are as follows:

$$f_{\text{POLE1}} \approx \frac{1}{2\pi \cdot 10e^6 \cdot CC1} \text{ which is close to DC}$$

$$f_{\text{ZERO1}} = \frac{1}{2\pi \cdot R_Z \cdot CC1}$$

$$f_{\text{POLE2}} \approx \frac{1}{2\pi \cdot R_Z \cdot CC2}$$

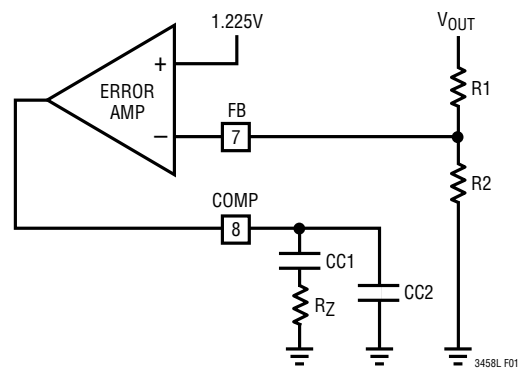
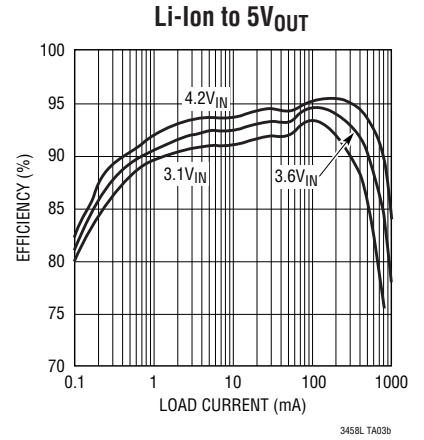
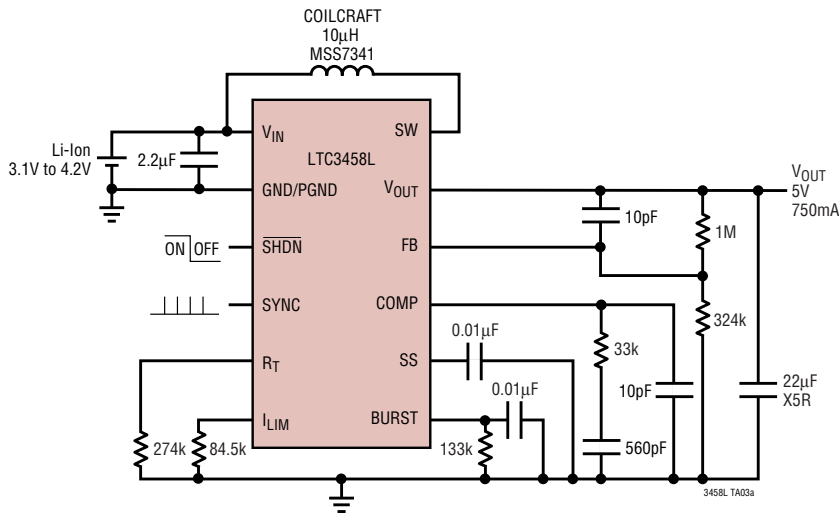

Figure 2

TYPICAL APPLICATIONS

Lithium-Ion to 5V, 750mA at 750kHz



Two Cell to 5V_{OUT}, 250mA at 750kHz

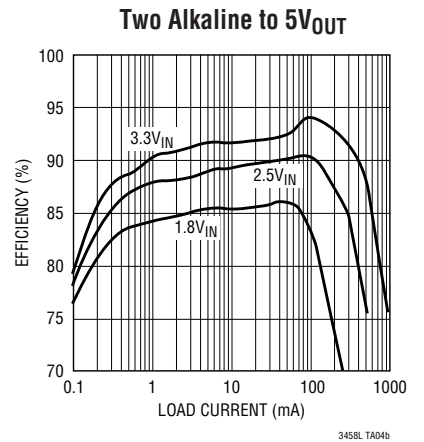
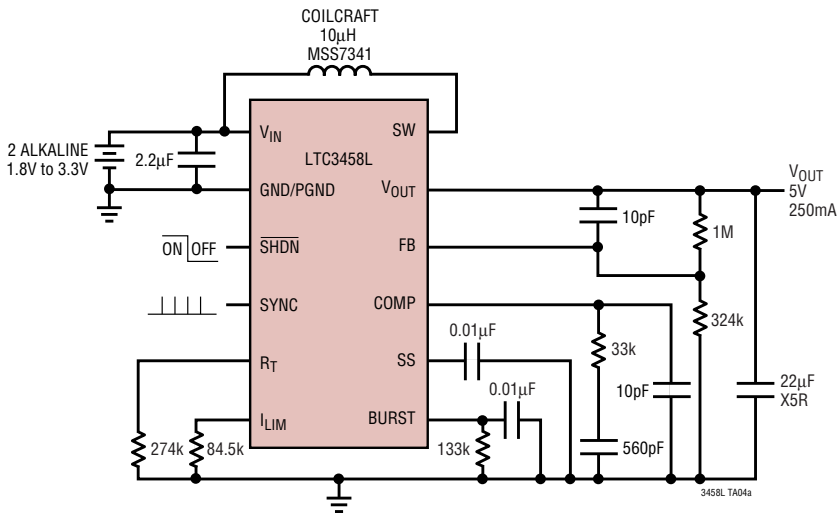

TYPICAL APPLICATION

High Current LED Driver with BURST Pin Current Regulation

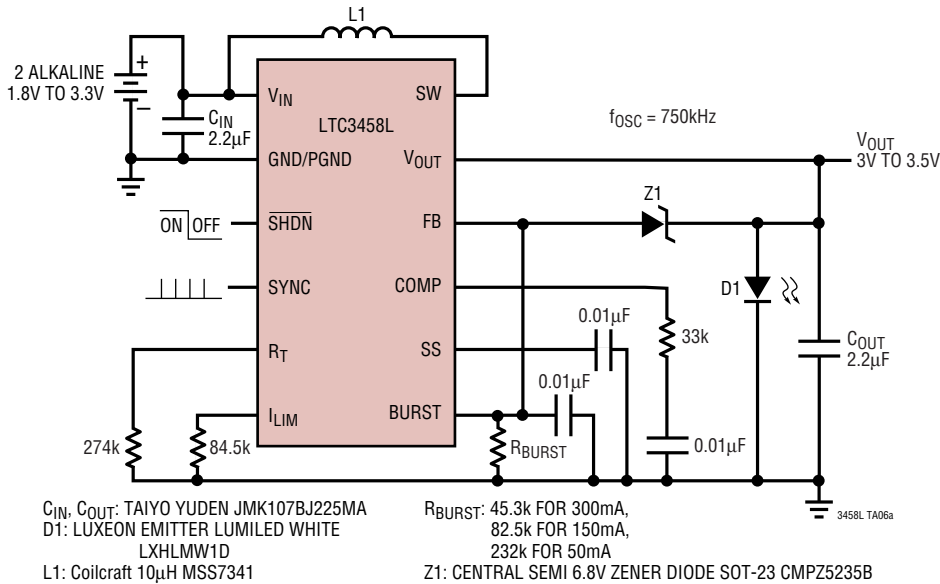

Two Alkaline Cells Powering a 1-Watt Lumiled

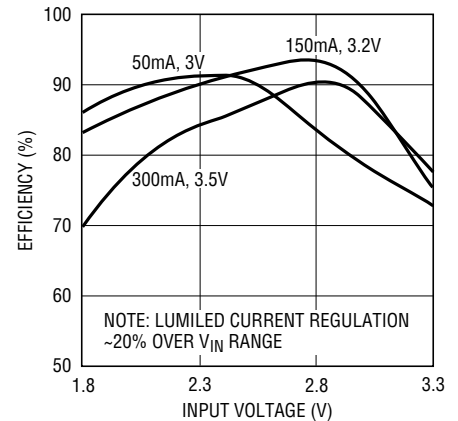

RELATED PARTS

PART NUMBER	DESCRIPTION	COMMENTS
LT1310	1.5A I_{SW} , 4.5MHz, High Efficiency Step-Up DC/DC Converter	V_{IN} : 2.75V to 18V, $V_{OUT(MAX)}$ = 35V, I_Q = 12mA, I_{SD} < 1µA, MS10E
LT1613	550mA I_{SW} , 1.4MHz, High Efficiency Step-Up DC/DC Converter	V_{IN} : 0.9V to 10V, $V_{OUT(MAX)}$ = 34V, I_Q = 3mA, I_{SD} < 1µA, ThinSOT
LT1615/ LT1615-1	300mA/80mA I_{SW} , Constant Off-Time, High Efficiency Step-Up DC/DC Converter	V_{IN} : 1.2V to 15V, $V_{OUT(MAX)}$ = 34V, I_Q = 20µA, I_{SD} < 1µA, ThinSOT
LT1618	1.5A I_{SW} , 1.4MHz, High Efficiency Step-Up DC/DC Converter	V_{IN} : 1.6V to 18V, $V_{OUT(MAX)}$ = 35V, I_Q = 1.8mA, I_{SD} < 1µA, MS10
LT1946/LT1946A	1.5A I_{SW} , 1.2MHz/2.7MHz, High Efficiency Step-Up DC/DC Converter	V_{IN} : 2.45V to 16V, $V_{OUT(MAX)}$ = 34V, I_Q = 3.2mA, I_{SD} < 1µA, MS8
LT1961	1.5A I_{SW} , 1.25MHz, High Efficiency Step-Up DC/DC Converter	V_{IN} : 3V to 25V, $V_{OUT(MAX)}$ = 35V, I_Q = 0.9mA, I_{SD} < 6µA, MS8E
LTC3400/ LTC3400B	600mA I_{SW} , 1.2MHz, Synchronous Step-Up DC/DC Converter	V_{IN} : 0.5V to 5V, $V_{OUT(MAX)}$ = 5V, I_Q = 19µA/300µA I_{SD} < 1µA, ThinSOT
LTC3401	1A I_{SW} , 3MHz, Synchronous Step-Up DC/DC Converter	V_{IN} : 0.5V to 5V, $V_{OUT(MAX)}$ = 6V, I_Q = 38µA I_{SD} < 1µA, MS10
LTC3402	2A I_{SW} , 3MHz, Synchronous Step-Up DC/DC Converter	V_{IN} : 0.5V to 5V, $V_{OUT(MAX)}$ = 6V, I_Q = 38µA I_{SD} < 1µA, MS10
LTC3421	3A I_{SW} , 3MHz, Synchronous Step-Up DC/DC Converter	V_{IN} : 0.5V to 4.5V, $V_{OUT(MAX)}$ = 2.4V to 5.25V
LTC3425	5A I_{SW} , 8MHz, 4-Phase Synchronous Step-Up DC/DC Converter QFN32	V_{IN} : 0.5V to 4.5V, $V_{OUT(MAX)}$ = 5.25V, I_Q = 12µA, I_{SD} < 1µA,
LTC3429	600mA, 500kHz, Synchronous Step-Up DC/DC Converter with Output Disconnect and Soft-Start	V_{IN} : 0.5V to 5V, $V_{OUT(MAX)}$ = 5V, I_Q = 20µA/300µA I_{SD} < 1µA, ThinSOT
LTC3458	1.4A I_{SW} , 1.5MHz, High Efficiency Step-Up DC/DC Converter	V_{IN} : 1.5V to 6V, $V_{OUT(MAX)}$ = Up to 7.5V
LTC3459	70mA I_{SW} , 10V Micropower Synchronous Boost/Output Disconnect	V_{IN} : 1.5V to 5.5V, $V_{OUT(MAX)}$ = 10V, I_Q = 10µA, ThinSOT
LT3460	320mA I_{SW} , 1.3MHz, High Efficiency Step-Up DC/DC Converter	V_{IN} : 2.5V to 16V, $V_{OUT(MAX)}$ = 36V, I_Q = 2mA, I_{SD} < 1µA, SC70, ThinSOT
LT3464	85mA I_{SW} , Constant Off-Time, High Efficiency Step-Up DC/DC Converter with Integrated Schottky/Output Disconnect	V_{IN} : 2.3V to 10V, $V_{OUT(MAX)}$ = 34V, I_Q = 25µA, I_{SD} < 1µA, ThinSOT

3458lfa

Looking for pricing, stock, or lifecycle information?

Click below to explore more details on WIN SOURCE:

 [View LTC3458LEDE#PBF on WIN SOURCE](#)

 [Linear Technology](#) Information

Optimize Your Supply Chain with WIN SOURCE Solutions

-  Global Sourcing Solution
-  Obsolete Management
-  Cost Control Management
-  Shortage Management
-  Alternative Solution
-  Excess Inventory Management