



**THE DATASHEET OF  
LTC3717EUH-1#TRPBF**



# Wide Operating Range, No $R_{SENSE}$ ™ Step-Down Controller for DDR/QDR Memory Termination

## FEATURES

- $V_{OUT} = 1/2 V_{REF}$
- Adjustable and Symmetrical Sink/Source Current Limit up to 20A
- True Current Mode Control with Optional Use of Sense Resistor
- $V_{ON}$  and  $I_{ON}$  Pins Allow Constant Frequency Operation During Input and Output Voltage Changes
- $\pm 0.65\%$  Output Voltage Accuracy
- Up to 97% Efficiency
- Ultrafast Transient Response
- 2% to 90% Duty Cycle at 200kHz
- $t_{ON(MIN)} \leq 100ns$
- Stable with Ceramic  $C_{OUT}$
- Power Good Output Voltage Monitor
- Wide  $V_{IN}$  Range: 4V to 36V
- Adjustable Switching Frequency up to 1.5MHz
- Output Overvoltage Protection
- Optional Short-Circuit Shutdown Timer
- Available in a 5mm × 5mm QFN Package

## APPLICATIONS

- Bus Termination: DDR and QDR Memory, SSTL, HSTL, ...
- Notebook Computers, Desktop Servers
- Tracking/Margining Power Supply

## DESCRIPTION

The LTC<sup>®</sup>3717-1 is a synchronous step-down switching regulator controller for double data rate (DDR) and Quad Data Rate™ (QDR™) memory termination. The controller uses a valley current control architecture to deliver very low duty cycles with or without a sense resistor. Operating frequency is selected by an external resistor and is compensated for variations in  $V_{IN}$  and  $V_{OUT}$ .

Forced continuous operation reduces noise and RF interference. Output voltage is internally set to half of  $V_{REF}$ , which is user programmable.

Fault protection is provided by an output overvoltage comparator and optional short-circuit shutdown timer. Soft-start capability for supply sequencing is accomplished using an external timing capacitor. The regulator current limit level is symmetrical and user programmable. Wide supply range allows operation from 4V to 36V at the  $V_{CC}$  input.

LT, LTC and LT are registered trademarks of Linear Technology Corporation.

No  $R_{SENSE}$  is a trademark of Linear Technology Corporation.

QDR RAMs and Quad Data Rate RAMs comprise a new family of products developed by Cypress Semiconductor, Hitachi, IDT, Micron Technology, Inc. and Samsung.

## TYPICAL APPLICATION

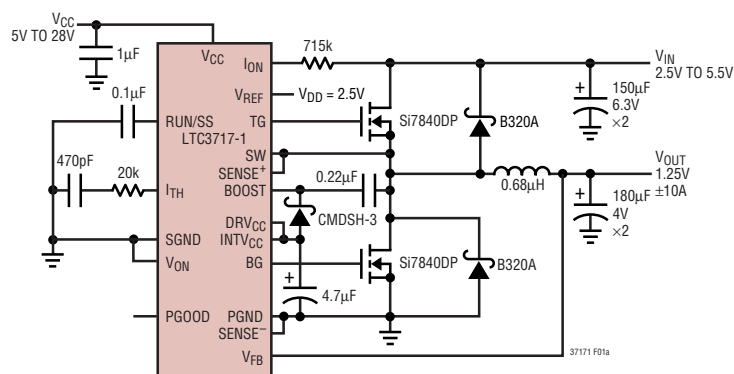
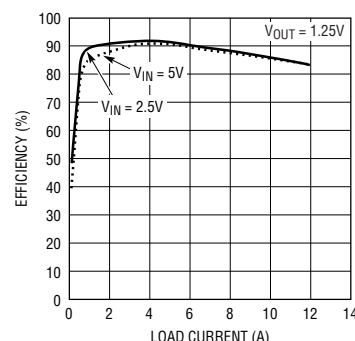

Figure 1. High Efficiency DDR Memory Termination Supply

### Efficiency vs Load Current



37171 F01b

sn37171 37171fs

## ABSOLUTE MAXIMUM RATINGS

(Note 1)

Boosted Topside Driver Supply Voltage (BOOST) .....	42V to -0.3V
$V_{IN}$ , $I_{ON}$ , SW, SENSE+ Voltage .....	36V to -0.3V
EXTV <sub>CC</sub> , DRV <sub>CC</sub> , RUN/SS, PGOOD, (BOOST - SW) Voltages .....	7V to -0.3V
$V_{ON}$ , $V_{REF}$ , $V_{RNG}$ Voltages .....	(INTV <sub>CC</sub> + 0.3V) to -0.3V
$I_{TH}$ , $V_{FB}$ Voltages .....	2.7V to -0.3V
TG, BG, INTV <sub>CC</sub> , EXTV <sub>CC</sub> , DRV <sub>CC</sub> Peak Currents .....	2A
TG, BG, INTV <sub>CC</sub> , EXTV <sub>CC</sub> , DRV <sub>CC</sub> RMS Currents ..	50mA
Operating Ambient Temperature Range (Note 4) .....	-40°C to 85°C
Junction Temperature (Note 2) .....	125°C
Storage Temperature Range .....	-65°C to 125°C
Reflow Peak Body Temperature .....	260°C

## PACKAGE/ORDER INFORMATION

TOP VIEW

UH PACKAGE  
32-LEAD (5mm × 5mm) PLASTIC QFN  
 $T_{JMAX} = 125^{\circ}\text{C}$ ,  $\theta_{JA} = 34^{\circ}\text{C/W}$   
EXPOSED PAD IS SGND (PIN 33) MUST BE SOLDERED TO PCB

ORDER PART NUMBER	QFN PART MARKING
LTC3717EUH-1	37171

Consult LTC Marketing for parts specified with wider operating temperature ranges.

## ELECTRICAL CHARACTERISTICS

The ● denotes specifications which apply over the full operating temperature range, otherwise specifications are  $T_A = 25^{\circ}\text{C}$ .  $V_{IN} = 15\text{V}$ , unless otherwise noted.

SYMBOL	PARAMETER	CONDITIONS	MIN	TYP	MAX	UNITS
<b>Buck Regulator</b>						
$I_{Q(VIN)}$	Input DC Supply Current ( $V_{IN}$ ) Normal			1000	2000	$\mu\text{A}$
	Shutdown Supply Current	$V_{RUN/SS} = 0\text{V}$		15	30	$\mu\text{A}$
$V_{FB}$	Feedback Voltage Accuracy	$I_{TH} = 1.2\text{V}$ (Note 3), $V_{REF} = 2.4\text{V}$	● -0.65	0.1	0.65	%
$\Delta V_{FB(LINE)}$	Feedback Voltage Line Regulation	$V_{IN} = 4\text{V}$ to $36\text{V}$ , $I_{TH} = 1.2\text{V}$ (Note 3)		0.002		%/V
$\Delta V_{FB(LOAD)}$	Feedback Voltage Load Regulation	$I_{TH} = 0.5\text{V}$ to $1.9\text{V}$ (Note 3)	● -0.05		-0.3	%
$g_{m(EA)}$	Error Amplifier Transconductance	$I_{TH} = 1.2\text{V}$ (Note 3)	0.93	1.13	1.33	mS
$t_{ON}$	On-Time	$I_{ON} = 30\mu\text{A}$ , $V_{ON} = 0\text{V}$	186	233	280	ns
		$I_{ON} = 60\mu\text{A}$ , $V_{ON} = 0\text{V}$	95	115	135	ns
$t_{ON(MIN)}$	Minimum On-Time	$I_{ON} = 180\mu\text{A}$		50	100	ns
$t_{OFF(MIN)}$	Minimum Off-Time			300	400	ns
$V_{SENSE(MAX)}$	Maximum Current Sense Threshold $V_{PGND} - V_{SW}$ (Source)	$V_{RNG} = 1\text{V}$ , $V_{FB} = V_{REF}/2 - 50\text{mV}$	● 108	135	162	mV
		$V_{RNG} = 0\text{V}$ , $V_{FB} = V_{REF}/2 - 50\text{mV}$	● 76	95	114	mV
		$V_{RNG} = \text{INTV}_{CC}$ , $V_{FB} = V_{REF}/2 - 50\text{mV}$	● 148	185	222	mV
$V_{SENSE(MIN)}$	Minimum Current Sense Threshold $V_{PGND} - V_{SW}$ (Sink)	$V_{RNG} = 1\text{V}$ , $V_{FB} = V_{REF}/2 + 50\text{mV}$	● -140	-165	-190	mV
		$V_{RNG} = 0\text{V}$ , $V_{FB} = V_{REF}/2 + 50\text{mV}$	● -97	-115	-133	mV
		$V_{RNG} = \text{INTV}_{CC}$ , $V_{FB} = V_{REF}/2 + 50\text{mV}$	● -200	-235	-270	mV

## ELECTRICAL CHARACTERISTICS

The ● denotes specifications which apply over the full operating temperature range, otherwise specifications are  $T_A = 25^\circ\text{C}$ .  $V_{IN} = 15\text{V}$ , unless otherwise noted.

SYMBOL	PARAMETER	CONDITIONS	MIN	TYP	MAX	UNITS
$\Delta V_{FB(OV)}$	Output Overvoltage Fault Threshold		8	10	12	%
$V_{FB(UV)}$	Output Undervoltage Threshold			-25		%
$V_{RUN/SS(ON)}$	RUN Pin Start Threshold		● 0.8	1.5	2	V
$V_{RUN/SS(LE)}$	RUN Pin Latchoff Enable	RUN/SS Pin Rising		4	4.5	V
$V_{RUN/SS(LT)}$	RUN Pin Latchoff Threshold	RUN/SS Pin Falling		3.5	4.2	V
$I_{RUN/SS(C)}$	Soft-Start Charge Current	$V_{RUN/SS} = 0\text{V}$	-0.5	-1.2	-3	$\mu\text{A}$
$I_{RUN/SS(D)}$	Soft-Start Discharge Current	$V_{RUN/SS} = 4.5\text{V}$ , $V_{FB} = 0\text{V}$	0.8	1.8	3	$\mu\text{A}$
$V_{IN(UVLO)}$	$V_{IN}$ Undervoltage Lockout	$V_{IN}$ Falling	●	3.4	3.9	V
		$V_{IN}$ Rising	●	3.5	4.0	V
TG $R_{UP}$	TG Driver Pull-Up On Resistance	TG High (Note 5)		2		$\Omega$
TG $R_{DOWN}$	TG Driver Pull-Down On Resistance	TG Low (Note 5)		2		$\Omega$
BG $R_{UP}$	BG Driver Pull-Up On Resistance	BG High (Note 5)		3		$\Omega$
BG $R_{DOWN}$	BG Driver Pull-Down On Resistance	BG Low (Note 5)		1		$\Omega$
TG $t_r$	TG Rise Time	$C_{LOAD} = 3300\text{pF}$		20		ns
TG $t_f$	TG Fall Time	$C_{LOAD} = 3300\text{pF}$		20		ns
BG $t_r$	BG Rise Time	$C_{LOAD} = 3300\text{pF}$		20		ns
BG $t_f$	BG Fall Time	$C_{LOAD} = 3300\text{pF}$		20		ns

### Internal $V_{CC}$ Regulator

$V_{INTVCC}$	Internal $V_{CC}$ Voltage	$6\text{V} < V_{CC} < 30\text{V}$ , $V_{EXTVCC} = 4\text{V}$	● 4.7	5	5.3	V
$\Delta V_{LDO(LOADREG)}$	Internal $V_{CC}$ Load Regulation	$I_{CC} = 0\text{mA}$ to $20\text{mA}$ , $V_{EXTVCC} = 4\text{V}$		-0.1	$\pm 2$	%
$V_{EXTVCC}$	EXTV $_{CC}$ Switchover Voltage	$I_{CC} = 20\text{mA}$ , V $_{EXTVCC}$ Rising	● 4.5	4.7		V
$\Delta V_{EXTVCC}$	EXTV $_{CC}$ Switch Drop Voltage	$I_{CC} = 20\text{mA}$ , V $_{EXTVCC} = 5\text{V}$		150	300	mV
$\Delta V_{EXTVCC(HYS)}$	EXTV $_{CC}$ Switchover Hysteresis			200		mV

### PGOOD Output

$\Delta V_{FBH}$	PGOOD Upper Threshold	$V_{FB}$ Rising (0% = $1/3 V_{REF}$ )	8	10	12	%
$\Delta V_{FBL}$	PGOOD Lower Threshold	$V_{FB}$ Falling (0% = $1/3 V_{REF}$ )	-8	-10	-12	%
$\Delta V_{FB(HYS)}$	PGOOD Hysteresis	$V_{FB}$ Returning (0% = $1/3 V_{REF}$ )		1	2	%
$V_{PGL}$	PGOOD Low Voltage	$I_{PGOOD} = 5\text{mA}$		0.15	0.4	V

**Note 1:** Absolute Maximum Ratings are those values beyond which the life of a device may be impaired.

**Note 2:**  $T_J$  is calculated from the ambient temperature  $T_A$  and power dissipation  $P_D$  as follows:

$$T_{J3717EUH-1} = T_A + (P_D \cdot 34^\circ\text{C/W})$$

**Note 3:** The LTC3717EUH-1 is tested in a feedback loop that adjusts  $V_{FB}$  to achieve a specified error amplifier output voltage ( $I_{TH}$ ).

**Note 4:** The LTC3717EUH-1 is guaranteed to meet performance specifications from  $0^\circ\text{C}$  to  $70^\circ\text{C}$ . Specifications over the  $-40^\circ\text{C}$  to  $85^\circ\text{C}$  operating temperature range are assured by design, characterization and correlation with statistical process controls.

**Note 5:**  $R_{DS(ON)}$  limit guaranteed by design and/or correlation to static test.

# TYPICAL PERFORMANCE CHARACTERISTICS

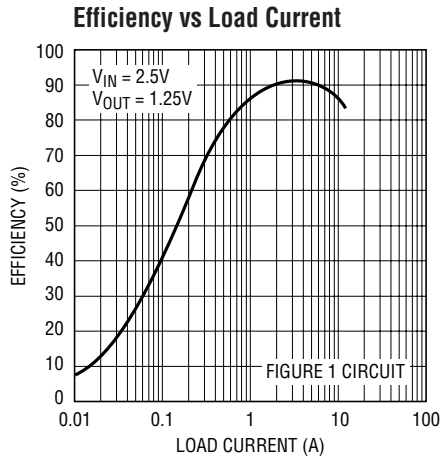

37171 G01

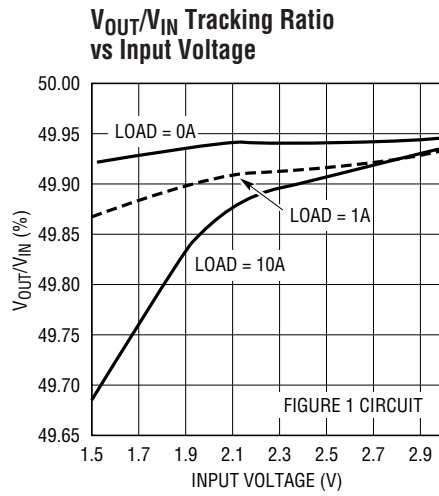

37171 G02

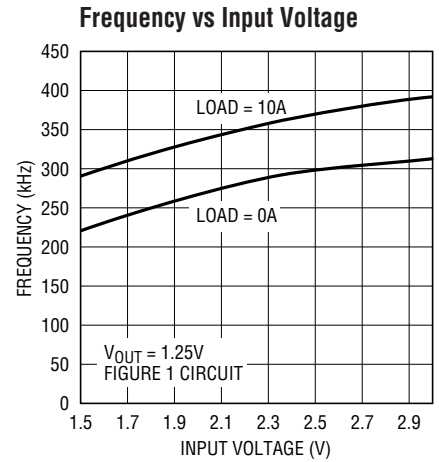

37171 G03

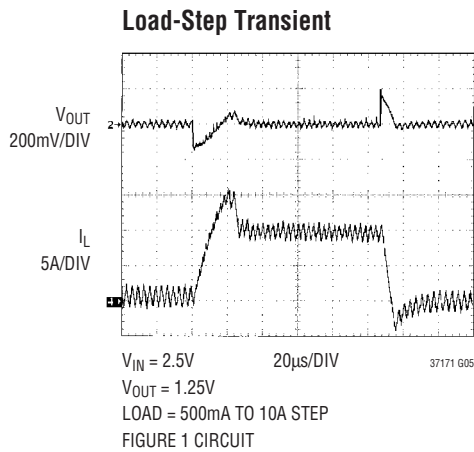

37171 G05

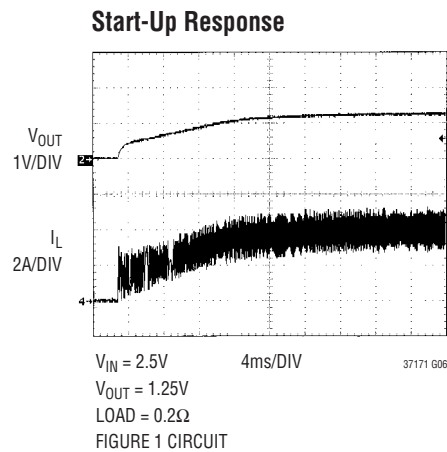

37171 G06

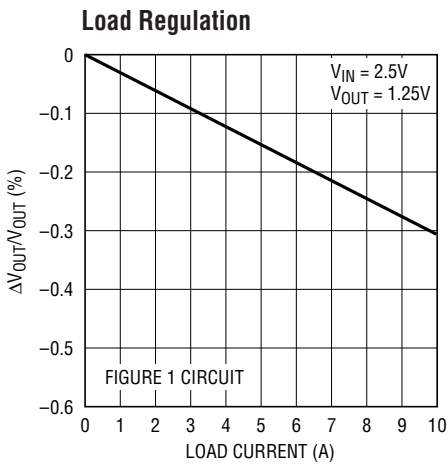

37171 G04

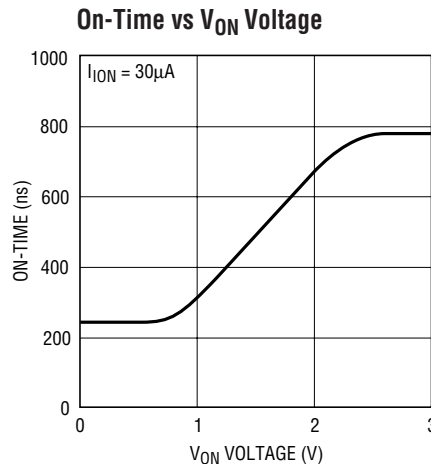

37171 G07

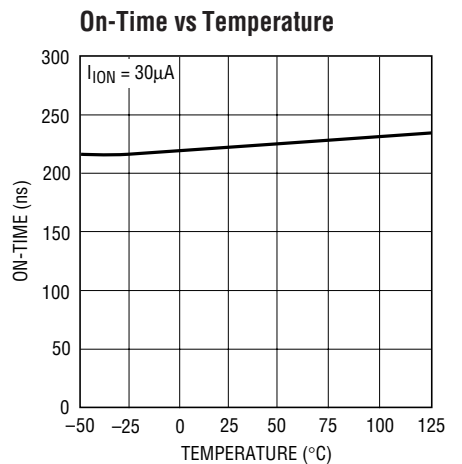

37171 G08

# TYPICAL PERFORMANCE CHARACTERISTICS

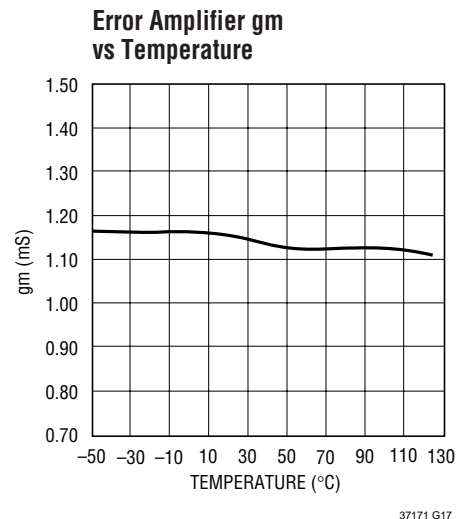
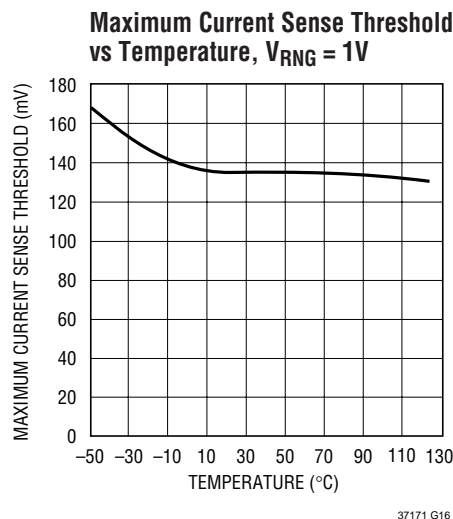
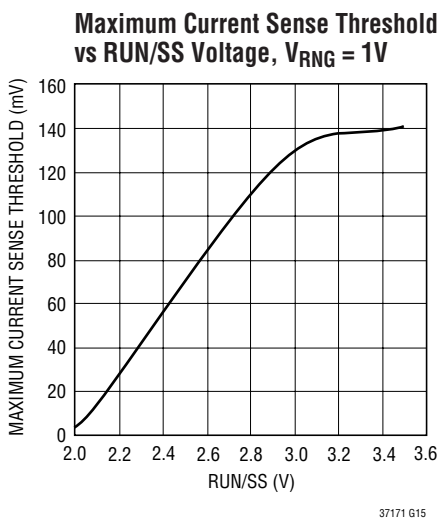
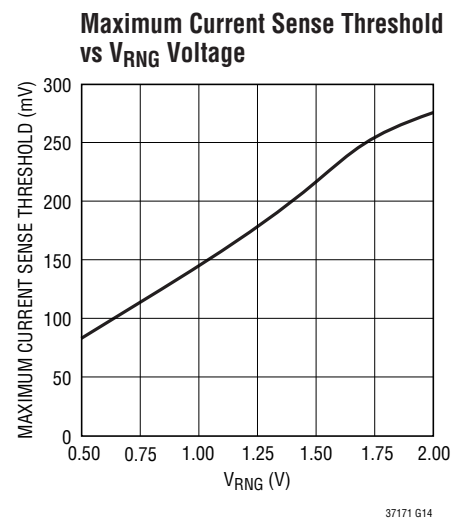
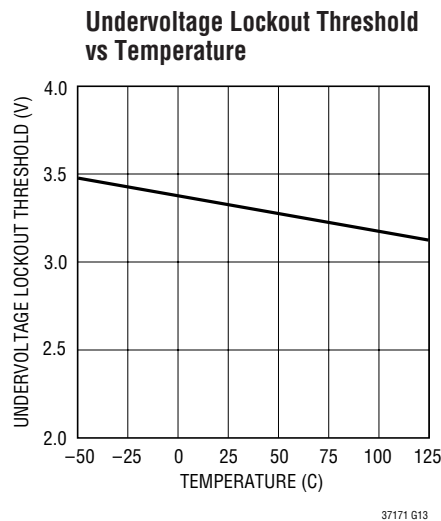
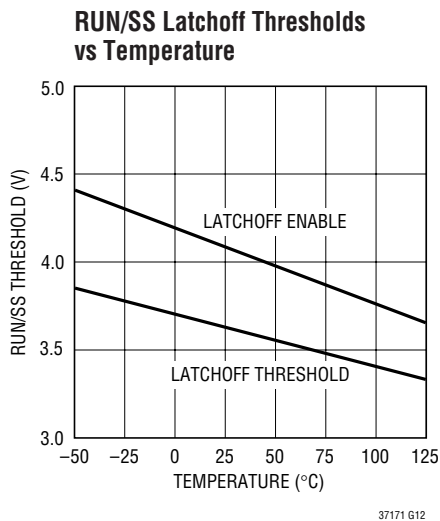
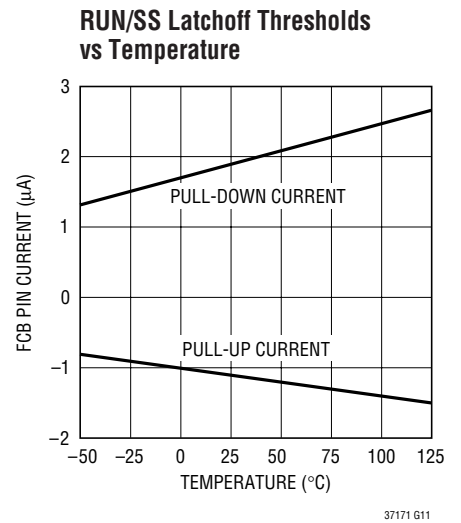
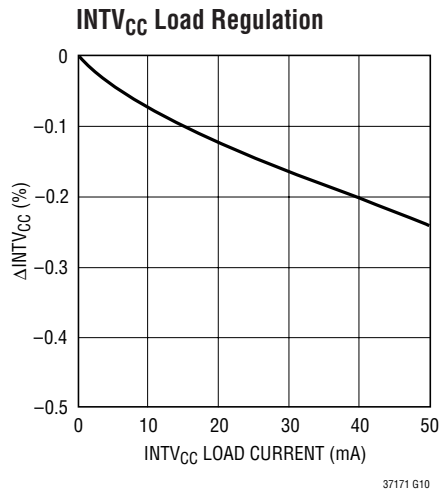
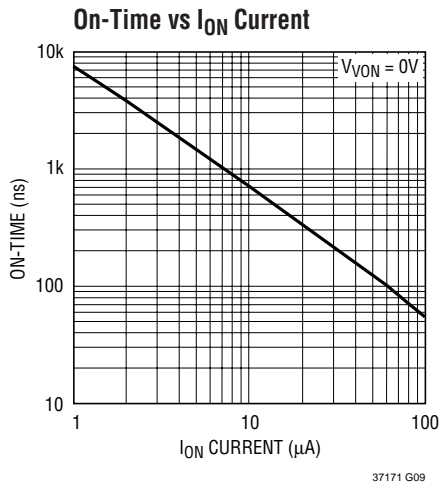

## PIN FUNCTIONS

**V<sub>ON</sub> (Pin 1):** On-Time Voltage Input. Voltage trip point for the on-time comparator. Tying this pin to the output voltage makes the on-time proportional to V<sub>OUT</sub>. The comparator input defaults to 0.7V when the pin is grounded, 2.4V when the pin is tied to INTV<sub>CC</sub>.

**PGOOD (Pin 2):** Power Good Output. Open-drain logic output that is pulled to ground when the output voltage is not within  $\pm 10\%$  of the regulation point.

**V<sub>RNG</sub> (Pin 3):** Sense Voltage Range Input. The voltage at this pin is ten times the nominal sense voltage at maximum output current and can be set from 0.5V to 2V by a resistive divider from INTV<sub>CC</sub>. The nominal sense voltage defaults to 70mV when this pin is tied to ground, 140mV when tied to INTV<sub>CC</sub>.

**I<sub>TH</sub> (Pin 4):** Current Control Threshold and Error Amplifier Compensation Point. The current comparator threshold increases with this control voltage. The voltage ranges from 0V to 2.4V with 0.8V corresponding to zero sense voltage (zero current).

**SGND (Pin 5)/Exposed Pad (Pin 33):** Signal Ground. All small-signal components and compensation components should connect to this ground, which in turn connects to PGND at one point. Pin 5 is electrically connected to the exposed pad. Exposed pad must be soldered to PCB.

**I<sub>ON</sub> (Pin 6):** On-Time Current Input. Tie a resistor from V<sub>IN</sub> to this pin to set the one-shot timer current and thereby set the switching frequency.

**V<sub>FB</sub> (Pin 7):** Error Amplifier Feedback Input. This pin connects to V<sub>OUT</sub> and divides its voltage to  $\frac{2}{3} \cdot V_{FB}$  through precision internal resistors before it is applied to the input of the error amplifier. Do not apply more than 1.5V on V<sub>FB</sub>. For higher output voltages, attach an external resistor R<sub>2</sub> ( $\frac{1}{2} \cdot R_1$  at V<sub>REF</sub>) from V<sub>OUT</sub> to V<sub>FB</sub>.

**NC (Pins 8, 9, 11, 12, 13, 14, 22, 25, 26, 29, 30, 32):** Do Not Connect.

**V<sub>REF</sub> (Pin 10):** Positive Input of Internal Error Amplifier. This pin connects to an external reference and divides its voltage to  $\frac{1}{3} V_{REF}$  through precision internal resistors before it is applied to the positive input of the error amplifier. Reference voltage for output voltage, power

good threshold, and short-circuit shutdown threshold. Do not apply more than 3V on V<sub>REF</sub>. If higher voltages are used, connect an external resistor ( $R_1 \geq 160k$ ) from voltage reference to V<sub>REF</sub>.

**EXTV<sub>CC</sub> (Pin 15):** External V<sub>CC</sub> Input. When EXTV<sub>CC</sub> exceeds 4.7V, an internal switch connects this pin to INTV<sub>CC</sub> and shuts down the internal regulator so that controller and gate drive power is drawn from EXTV<sub>CC</sub>. Do not exceed 7V at this pin and ensure that EXTV<sub>CC</sub> < V<sub>IN</sub>.

**V<sub>IN</sub> (Pin 16):** Main Input Supply. Decouple this pin to PGND with an RC filter (1 $\Omega$ , 0.1 $\mu$ F).

**INTV<sub>CC</sub> (Pin 17):** Internal Regulator Output. The control circuits are powered from this voltage when V<sub>IN</sub> is greater than 5V. Decouple this pin to power ground with a minimum of 4.7 $\mu$ F low ESR tantalum or ceramic capacitor.

**DRV<sub>CC</sub> (Pin 18):** Voltage Supply to Bottom Gate Driver. Normally connected to the INTV<sub>CC</sub> pin through a decoupling RC filter (1 $\Omega$ /0.1 $\mu$ F). Decouple this pin to power ground with a minimum of 4.7 $\mu$ F low ESR tantalum or ceramic capacitor. Do not exceed 7V at this pin.

**BG (Pin 19):** Bottom Gate Drive. Drives the gate of the bottom N-channel MOSFET between ground and DRV<sub>CC</sub>.

**PGND (Pin 20):** Power Ground. Connect these pins closely to the source of the bottom N-channel MOSFET, the (–) terminal of C<sub>VCC</sub> and the (–) terminal of C<sub>IN</sub>.

**SENSE<sup>–</sup> (Pin 21):** Negative Current Sense Comparator Input. The (–) input to the current comparator is normally connected to power ground unless using a resistive divider from INTV<sub>CC</sub> (see Applications Information).

**SENSE<sup>+</sup> (Pin 23):** Positive Current Sense Comparator Input. The (+) input to the current comparator is normally connected to the SW node unless using a sense resistor (see Applications Information).

**SW (Pin 24):** Switch Node. The (–) terminal of the bootstrap capacitor C<sub>B</sub> connects here. This pin swings from a diode voltage drop below ground up to V<sub>IN</sub>.

**TG (Pin 27):** Top Gate Drive. Drives the top N-channel MOSFET with a voltage swing equal to INTV<sub>CC</sub> superimposed on the switch node voltage SW.

## PIN FUNCTIONS

**BOOST (Pin 28):** Boosted Floating Driver Supply. The (+) terminal of the bootstrap capacitor  $C_B$  connects here. This pin swings from a diode voltage drop below  $INTV_{CC}$  up to  $V_{IN} + INTV_{CC}$ .

**RUN/SS (Pin 31):** Run Control and Soft-Start Input. A capacitor to ground at this pin sets the ramp time to full output current (approximately  $3s/\mu F$ ) and the time delay for overcurrent latching (see Applications Information). Forcing this pin below  $0.8V$  shuts down the device.

## FUNCTIONAL DIAGRAM

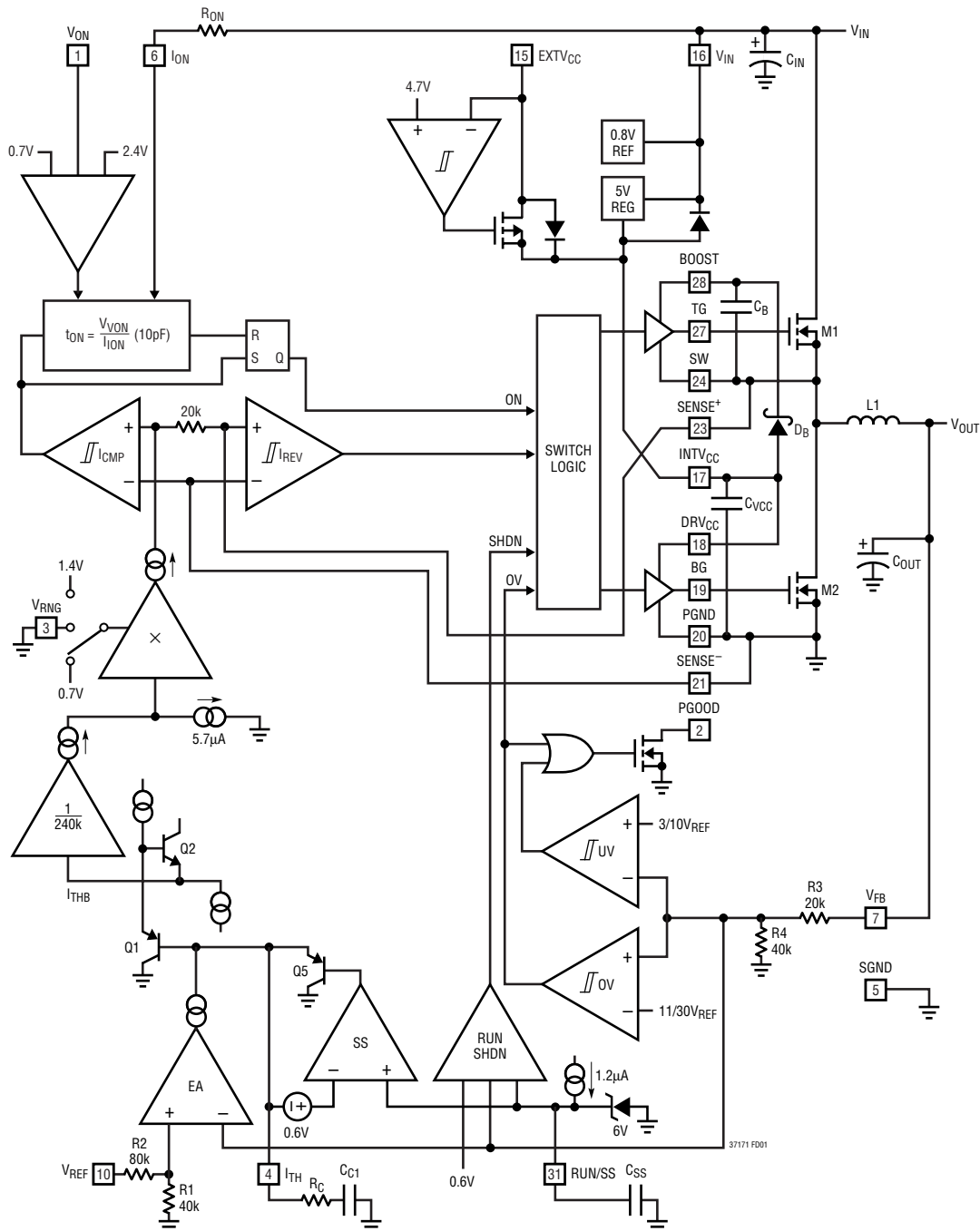

## OPERATION

### Main Control Loop

The LTC3717-1 is a current mode controller for DC/DC step-down converters. In normal operation, the top MOSFET is turned on for a fixed interval determined by a one-shot timer OST. When the top MOSFET is turned off, the bottom MOSFET is turned on until the current comparator  $I_{CMP}$  trips, restarting the one-shot timer and initiating the next cycle. Inductor current is determined by sensing the voltage between the SENSE<sup>+</sup> and SENSE<sup>-</sup> pins using the bottom MOSFET on-resistance. The voltage on the  $I_{TH}$  pin sets the comparator threshold corresponding to inductor valley current. The error amplifier EA adjusts this  $I_{TH}$  voltage by comparing 2/3 of the feedback signal  $V_{FB}$  from the output voltage with a reference equal to 1/3 of the  $V_{REF}$  voltage. If the load current increases, it causes a drop in the feedback voltage relative to the reference. The  $I_{TH}$  voltage then rises until the average inductor current again matches the load current. As a result in normal DDR operation  $V_{OUT}$  is equal to 1/2 of the  $V_{REF}$  voltage.

The operating frequency is determined implicitly by the top MOSFET on-time and the duty cycle required to maintain regulation. The one-shot timer generates an on-time that is proportional to the ideal duty cycle, thus holding frequency approximately constant with changes in  $V_{IN}$ . The nominal frequency can be adjusted with an external resistor  $R_{ON}$ .

Overvoltage and undervoltage comparators OV and UV pull the PGOOD output low if the output feedback voltage exits a  $\pm 10\%$  window around the regulation point.

Furthermore, in an overvoltage condition, M1 is turned off and M2 is turned on and held on until the overvoltage condition clears.

Pulling the RUN/SS pin low forces the controller into its shutdown state, turning off both M1 and M2. Releasing the pin allows an internal 1.2 $\mu$ A current source to charge up an external soft-start capacitor  $C_{SS}$ . When this voltage reaches 1.5V, the controller turns on and begins switching, but with the  $I_{TH}$  voltage clamped at approximately 0.6V below the RUN/SS voltage. As  $C_{SS}$  continues to charge, the soft-start current limit is removed.

### INTV<sub>CC</sub>/EXTV<sub>CC</sub> Power

Power for the top and bottom MOSFET drivers and most of the internal controller circuitry is derived from the INTV<sub>CC</sub> pin. The top MOSFET driver is powered from a floating bootstrap capacitor  $C_B$ . This capacitor is recharged from INTV<sub>CC</sub> through an external Schottky diode  $D_B$  when the top MOSFET is turned off. When the EXTV<sub>CC</sub> pin is grounded, an internal 5V low dropout regulator supplies the INTV<sub>CC</sub> power from  $V_{CC}$ . If EXTV<sub>CC</sub> rises above 4.7V, the internal regulator is turned off, and an internal switch connects EXTV<sub>CC</sub> to INTV<sub>CC</sub>. This allows a high efficiency source connected to EXTV<sub>CC</sub>, such as an external 5V supply or a secondary output from the converter, to provide the INTV<sub>CC</sub> power. Voltages up to 7V can be applied to EXTV<sub>CC</sub> for additional gate drive. If the  $V_{CC}$  voltage is low and INTV<sub>CC</sub> drops below 3.4V, undervoltage lockout circuitry prevents the power switches from turning on.

## APPLICATIONS INFORMATION

A typical LTC3717-1 application circuit is shown in Figure 1. External component selection is primarily determined by the maximum load current and begins with the selection of the sense resistance and power MOSFET switches. The LTC3717-1 uses the on-resistance of the synchronous power MOSFET for determining the inductor current. The desired amount of ripple current and operating frequency largely determines the inductor value. Finally,  $C_{IN}$  is selected for its ability to handle the large RMS current into the converter and  $C_{OUT}$  is chosen with low enough ESR to meet the output voltage ripple and transient specification.

### Maximum Sense Voltage and $V_{RNG}$ Pin

Inductor current is determined by measuring the voltage across a sense resistance that appears between the  $SENSE^+$  and  $SENSE^-$  pins. The maximum sense voltage is set by the voltage applied to the  $V_{RNG}$  pin and is equal to approximately  $(0.13)V_{RNG}$  for sourcing current and  $(0.17)V_{RNG}$  for sinking current. The current mode control loop will not allow the inductor current valleys to exceed  $(0.13)V_{RNG}/R_{SENSE}$  for sourcing current and  $(0.17)V_{RNG}$  for sinking current. In practice, one should allow some margin for variations in the LTC3717-1 and external component values and a good guide for selecting the sense resistance is:

$$R_{SENSE} = \frac{V_{RNG}}{10 \cdot I_{OUT(MAX)}}$$

when  $V_{RNG} = 0.5 - 2V$ .

An external resistive divider from  $INTV_{CC}$  can be used to set the voltage of the  $V_{RNG}$  pin between 0.5V and 2V resulting in nominal sense voltages of 50mV to 200mV. Additionally, the  $V_{RNG}$  pin can be tied to  $SGND$  or  $INTV_{CC}$  in which case the nominal sense voltage defaults to 70mV or 140mV, respectively. The maximum allowed sense voltage is about 1.3 times this nominal value for positive output current and 1.7 times the nominal value for negative output current.

### Connecting the $SENSE^+$ and $SENSE^-$ Pins

The LTC3717-1 can be used with or without a sense resistor. When using a sense resistor, it is placed between

the source of the bottom MOSFET M2 and ground. Connect the  $SENSE^+$  and  $SENSE^-$  pins as a Kelvin connection to the sense resistor with  $SENSE^+$  at the source of the bottom MOSFET and the  $SENSE^-$  pin to  $PGND$ . Using a sense resistor provides a well defined current limit, but adds cost and reduces efficiency. Alternatively, one can eliminate the sense resistor and use the bottom MOSFET as the current sense element by simply connecting the  $SENSE^+$  pin to the drain and the  $SENSE^-$  pin to the source of the bottom MOSFET. This improves efficiency, but one must carefully choose the MOSFET on-resistance as discussed in a later section.

### Power MOSFET Selection

The LTC3717-1 requires two external N-channel power MOSFETs, one for the top (main) switch and one for the bottom (synchronous) switch. Important parameters for the power MOSFETs are the breakdown voltage  $V_{(BR)DSS}$ , threshold voltage  $V_{(GS)TH}$ , on-resistance  $R_{DS(ON)}$ , reverse transfer capacitance  $C_{RSS}$  and maximum current  $I_{DS(MAX)}$ .

The gate drive voltage is set by the 5V  $INTV_{CC}$  supply. Consequently, logic-level threshold MOSFETs must be used in LTC3717-1 applications.

When the bottom MOSFET is used as the current sense element, particular attention must be paid to its on-resistance. MOSFET on-resistance is typically specified with a maximum value  $R_{DS(ON)(MAX)}$  at 25°C. In this case, additional margin is required to accommodate the rise in MOSFET on-resistance with temperature:

$$R_{DS(ON)(MAX)} = \frac{R_{SENSE}}{\rho_T}$$

The  $\rho_T$  term is a normalization factor (unity at 25°C) accounting for the significant variation in on-resistance with temperature, typically about 0.4%/°C as shown in Figure 2. For a maximum junction temperature of 100°C, using a value  $\rho_T = 1.3$  is reasonable.

The power dissipated by the top and bottom MOSFETs strongly depends upon their respective duty cycles and the load current. During normal operation, the duty cycles for the MOSFETs are:

## APPLICATIONS INFORMATION

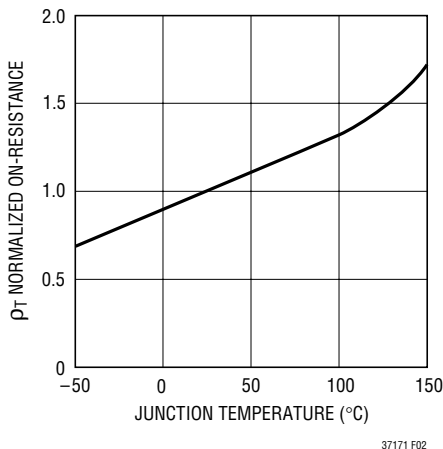
Figure 2.  $R_{DS(ON)}$  vs. Temperature

$$D_{TOP} = \frac{V_{OUT}}{V_{IN}}$$

$$D_{BOT} = \frac{V_{IN} - V_{OUT}}{V_{IN}}$$

The resulting power dissipation in the MOSFETs at maximum output current are:

$$P_{TOP} = D_{TOP} I_{OUT(MAX)}^2 \rho_{T(TOP)} R_{DS(ON)(MAX)} + k V_{IN}^2 I_{OUT(MAX)} C_{RSS} f$$

$$P_{BOT} = D_{BOT} I_{OUT(MAX)}^2 \rho_{T(BOT)} R_{DS(ON)(MAX)}$$

Both MOSFETs have  $I^2R$  losses and the top MOSFET includes an additional term for transition losses, which are largest at high input voltages. The constant  $k = 1.7A^{-1}$  can be used to estimate the amount of transition loss. The bottom MOSFET losses are greatest when the bottom duty cycle is near 100%, during a short-circuit or at high input voltage.

### Operating Frequency

The choice of operating frequency is a tradeoff between efficiency and component size. Low frequency operation improves efficiency by reducing MOSFET switching losses but requires larger inductance and/or capacitance in order to maintain low output ripple voltage.

The operating frequency of LTC3717-1 applications is determined implicitly by the one-shot timer that controls the on-time  $t_{ON}$  of the top MOSFET switch. The on-time is

set by the current into the  $I_{ON}$  pin and the voltage at the  $V_{ON}$  pin according to:

$$t_{ON} = \frac{V_{VON}}{I_{ON}} (10pF)$$

Tying a resistor  $R_{ON}$  from  $V_{IN}$  to the  $I_{ON}$  pin yields an on-time inversely proportional to  $V_{IN}$ . For a step-down converter, this results in approximately constant frequency operation as the input supply varies:

$$f = \frac{V_{OUT}}{V_{VON} R_{ON} (10pF)} \text{ [Hz]}$$

To hold frequency constant during output voltage changes, tie the  $V_{ON}$  pin to  $V_{OUT}$ . The  $V_{ON}$  pin has internal clamps that limit its input to the one-shot timer. If the pin is tied below 0.7V, the input to the one-shot is clamped at 0.7V. Similarly, if the pin is tied above 2.4V, the input is clamped at 2.4V.

Because the voltage at the  $I_{ON}$  pin is about 0.7V, the current into this pin is not exactly inversely proportional to  $V_{IN}$ , especially in applications with lower input voltages. To account for the 0.7V drop on the  $I_{ON}$  pin, the following equation can be used to calculate frequency:

$$f = \frac{(V_{IN} - 0.7V) \cdot V_{OUT}}{V_{VON} \cdot V_{IN} \cdot R_{ON} (10pF)}$$

To correct for this error, an additional resistor  $R_{ON2}$  connected from the  $I_{ON}$  pin to the 5V  $INTV_{CC}$  supply will further stabilize the frequency.

$$R_{ON2} = \frac{5V}{0.7V} R_{ON}$$

Changes in the load current magnitude will also cause frequency shift. Parasitic resistance in the MOSFET switches and inductor reduce the effective voltage across the inductance, resulting in increased duty cycle as the load current increases. By lengthening the on-time slightly as current increases, constant frequency operation can be maintained. This is accomplished with a resistive divider from the  $I_{TH}$  pin to the  $V_{ON}$  pin and  $V_{OUT}$ . The values required will depend on the parasitic resistances in the specific application. A good starting point is to feed about

sn37171 37171fs

## APPLICATIONS INFORMATION

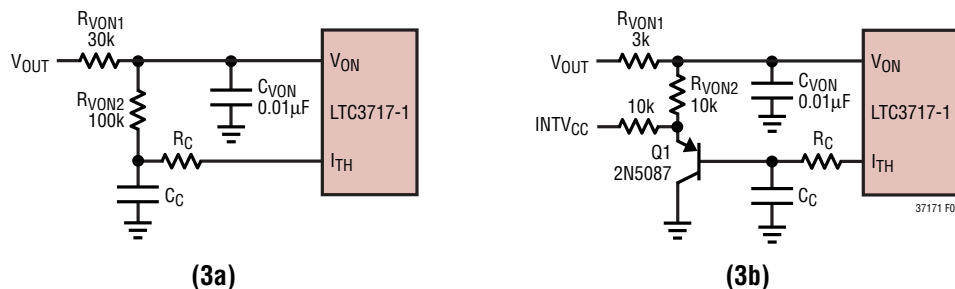

Figure 3. Adjusting Frequency Shift with Load Current Changes

25% of the voltage change at the  $I_{TH}$  pin to the  $V_{ON}$  pin as shown in Figure 3a. Place capacitance on the  $V_{ON}$  pin to filter out the  $I_{TH}$  variations at the switching frequency. The resistor load on  $I_{TH}$  reduces the DC gain of the error amp and degrades load regulation, which can be avoided by using the PNP emitter follower of Figure 3b.

## Inductor L1 Selection

Given the desired input and output voltages, the inductor value and operating frequency determine the ripple current:

$$\Delta I_L = \left( \frac{V_{OUT}}{fL} \right) \left( 1 - \frac{V_{OUT}}{V_{IN}} \right)$$

Lower ripple current reduces cores losses in the inductor, ESR losses in the output capacitors and output voltage ripple. Highest efficiency operation is obtained at low frequency with small ripple current. However, achieving this requires a large inductor. There is a tradeoff between component size, efficiency and operating frequency.

A reasonable starting point is to choose a ripple current that is about 40% of  $I_{OUT(MAX)}$ . The largest ripple current occurs at the highest  $V_{IN}$ . To guarantee that ripple current does not exceed a specified maximum, the inductance should be chosen according to:

$$L = \left( \frac{V_{OUT}}{f \Delta I_L(MAX)} \right) \left( 1 - \frac{V_{OUT}}{V_{IN(MAX)}} \right)$$

Once the value for L is known, the type of inductor must be selected. High efficiency converters generally cannot afford the core loss found in low cost powdered iron cores, forcing the use of more expensive ferrite, molypermalloy

or Kool M $\mu$ ® cores. A variety of inductors designed for high current, low voltage applications are available from manufacturers such as Sumida, Panasonic, Coiltronics, Coilcraft and Toko.

## Schottky Diode D1, D2 Selection

The Schottky diodes, D1 and D2, shown in Figure 1 conduct during the dead time between the conduction of the power MOSFET switches. It is intended to prevent the body diodes of the top and bottom MOSFETs from turning on and storing charge during the dead time, which can cause a modest (about 1%) efficiency loss. The diodes can be rated for about one half to one fifth of the full load current since they are on for only a fraction of the duty cycle. In order for the diode to be effective, the inductance between it and the bottom MOSFET must be as small as possible, mandating that these components be placed adjacently. The diodes can be omitted if the efficiency loss is tolerable.

 $C_{IN}$  and  $C_{OUT}$  Selection

The input capacitance  $C_{IN}$  is required to filter the square wave current at the drain of the top MOSFET. Use a low ESR capacitor sized to handle the maximum RMS current.

$$I_{RMS} \cong I_{OUT(MAX)} \frac{V_{OUT}}{V_{IN}} \sqrt{\frac{V_{IN}}{V_{OUT}} - 1}$$

This formula has a maximum at  $V_{IN} = 2V_{OUT}$ , where  $I_{RMS} = I_{OUT(MAX)}/2$ . This simple worst-case condition is commonly used for design because even significant deviations do not offer much relief. Note that ripple current ratings from capacitor manufacturers are often

Kool M $\mu$  is a registered trademark of Magnetics, Inc.

## APPLICATIONS INFORMATION

based on only 2000 hours of life which makes it advisable to derate the capacitor.

The selection of  $C_{OUT}$  is primarily determined by the ESR required to minimize voltage ripple and load step transients. The output ripple  $\Delta V_{OUT}$  is approximately bounded by:

$$\Delta V_{OUT} \leq \Delta I_L \left( \text{ESR} + \frac{1}{8fC_{OUT}} \right)$$

Since  $\Delta I_L$  increases with input voltage, the output ripple is highest at maximum input voltage. Typically, once the ESR requirement is satisfied, the capacitance is adequate for filtering and has the necessary RMS current rating.

Multiple capacitors placed in parallel may be needed to meet the ESR and RMS current handling requirements. Dry tantalum, special polymer, aluminum electrolytic and ceramic capacitors are all available in surface mount packages. Special polymer capacitors offer very low ESR but have lower capacitance density than other types. Tantalum capacitors have the highest capacitance density but it is important to only use types that have been surge tested for use in switching power supplies. Aluminum electrolytic capacitors have significantly higher ESR, but can be used in cost-sensitive applications providing that consideration is given to ripple current ratings and long term reliability. Ceramic capacitors have excellent low ESR characteristics but can have a high voltage coefficient and audible piezoelectric effects. The high Q of ceramic capacitors with trace inductance can also lead to significant ringing. When used as input capacitors, care must be taken to ensure that ringing from inrush currents and switching does not pose an overvoltage hazard to the power switches and controller. To dampen input voltage transients, add a small 5 $\mu$ F to 50 $\mu$ F aluminum electrolytic capacitor with an ESR in the range of 0.5 $\Omega$  to 2 $\Omega$ . High performance through-hole capacitors may also be used, but an additional ceramic capacitor in parallel is recommended to reduce the effect of their lead inductance.

### Top MOSFET Driver Supply ( $C_B$ , $D_B$ )

An external bootstrap capacitor  $C_B$  connected to the BOOST pin supplies the gate drive voltage for the topside MOSFET. This capacitor is charged through diode  $D_B$  from  $\text{INTV}_{CC}$  when the switch node is low. When the top MOSFET turns

on, the switch node rises to  $V_{IN}$  and the BOOST pin rises to approximately  $V_{IN} + \text{INTV}_{CC}$ . The boost capacitor needs to store about 100 times the gate charge required by the top MOSFET. In most applications a 0.1 $\mu$ F to 0.47 $\mu$ F X5R or X7R dielectric capacitor is adequate.

### Fault Condition: Current Limit

The maximum inductor current is inherently limited in a current mode controller by the maximum sense voltage. In the LTC3717-1, the maximum sense voltage is controlled by the voltage on the  $V_{RNG}$  pin. With valley current control, the maximum sense voltage and the sense resistance determine the maximum allowed inductor valley current. The corresponding output current limit is:

$$I_{LIMITPOSITIVE} = \frac{V_{SNS(MAX)}}{R_{DS(ON)PT}} + \frac{1}{2} \Delta I_L$$

$$I_{LIMITNEGATIVE} = \frac{V_{SNS(MIN)}}{R_{DS(ON)PT}} - \frac{1}{2} \Delta I_L$$

The current limit value should be checked to ensure that  $I_{LIMIT(MIN)} > I_{OUT(MAX)}$ . The minimum value of current limit generally occurs with the largest  $V_{IN}$  at the highest ambient temperature, conditions that cause the largest power loss in the converter. Note that it is important to check for self-consistency between the assumed MOSFET junction temperature and the resulting value of  $I_{LIMIT}$  which heats the MOSFET switches.

Caution should be used when setting the current limit based upon the  $R_{DS(ON)}$  of the MOSFETs. The maximum current limit is determined by the minimum MOSFET on-resistance. Data sheets typically specify nominal and maximum values for  $R_{DS(ON)}$ , but not a minimum. A reasonable assumption is that the minimum  $R_{DS(ON)}$  lies the same amount below the typical value as the maximum lies above it. Consult the MOSFET manufacturer for further guidelines.

### Minimum Off-time and Dropout Operation

The minimum off-time  $t_{OFF(MIN)}$  is the smallest amount of time that the LTC3717-1 is capable of turning on the bottom MOSFET, tripping the current comparator and turning the MOSFET back off. This time is generally about

## APPLICATIONS INFORMATION

250ns. The minimum off-time limit imposes a maximum duty cycle of  $t_{ON}/(t_{ON} + t_{OFF(MIN)})$ . If the maximum duty cycle is reached, due to a dropping input voltage for example, then the output will drop out of regulation. The minimum input voltage to avoid dropout is:

$$V_{IN(MIN)} = V_{OUT} \frac{t_{ON} + t_{OFF(MIN)}}{t_{ON}}$$

### Output Voltage Programming

When  $V_{FB}$  is connected to  $V_{OUT}$ , the output voltage is regulated to one half of the voltage at the  $V_{REF}$  pin. A resistor connected between  $V_{FB}$  and  $V_{OUT}$  can be used to further adjust the output voltage according to the following equation:

$$V_{OUT} = V_{REF} \left( \frac{60k + R_{FB}}{120k} \right)$$

If  $V_{REF}$  exceeds 3V, resistors should be placed in series with the  $V_{REF}$  pin and the  $V_{FB}$  pin to avoid exceeding the input common mode range of the internal error amplifier. To maintain the  $V_{OUT} = V_{REF}/2$  relationship, the resistor in series with the  $V_{REF}$  pin should be made twice as large as the resistor in series with the  $V_{FB}$  pin.

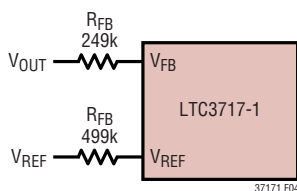

Figure 4

### External Gate Drive Buffers

The LTC3717-1 drivers are adequate for driving up to about 30nC into MOSFET switches with RMS currents of 50mA. Applications with larger MOSFET switches or operating at frequencies requiring greater RMS currents will benefit from using external gate drive buffers such as the LTC1693. Alternately, the external buffer circuit shown in Figure 5 can be used. Note that the bipolar devices reduce the signal swing at the MOSFET gate.

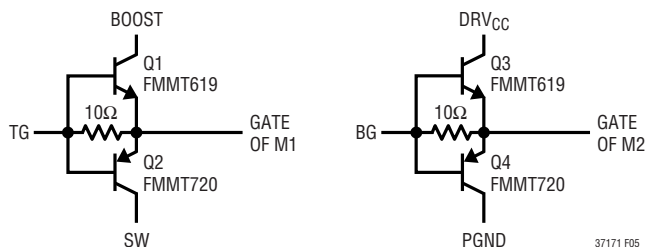

Figure 5. Optional External Gate Driver

### Soft-Start and Latchoff with the RUN/SS Pin

The RUN/SS pin provides a means to shut down the LTC3717-1 as well as a timer for soft-start and overcurrent latchoff. Pulling the RUN/SS pin below 0.8V puts the LTC3717-1 into a low quiescent current shutdown ( $I_Q < 30\mu A$ ). Releasing the pin allows an internal  $1.2\mu A$  current source to charge up the external timing capacitor  $C_{SS}$ . If RUN/SS has been pulled all the way to ground, there is a delay before starting of about:

$$t_{DELAY} = \frac{1.5V}{1.2\mu A} C_{SS} = (1.3s/\mu F) C_{SS}$$

When the voltage on RUN/SS reaches 1.5V, the LTC3717-1 begins operating with a clamp on  $I_{TH}$  of approximately 0.9V. As the RUN/SS voltage rises to 3V, the clamp on  $I_{TH}$  is raised until its full 2.4V range is available. This takes an additional  $1.3s/\mu F$ , during which the load current is folded back. During start-up, the maximum load current is reduced until either the RUN/SS pin rises to 3V or the output reaches 75% of its final value. The pin can be driven from logic as shown in Figure 6. Diode D1 reduces the start delay while allowing  $C_{SS}$  to charge up slowly for the soft-start function.

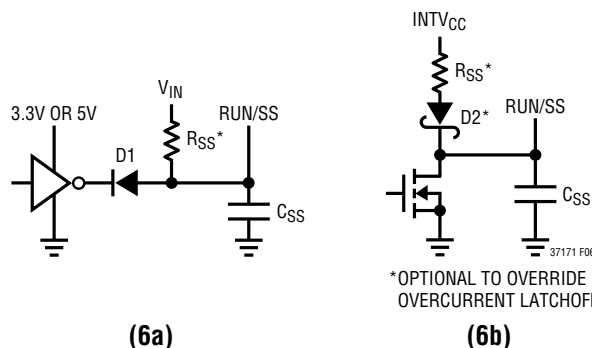

Figure 6. RUN/SS Pin Interfacing with Latchoff Defeated

## APPLICATIONS INFORMATION

After the controller has been started and given adequate time to charge up the output capacitor,  $C_{SS}$  is used as a short-circuit timer. After the RUN/SS pin charges above 4V, if the output voltage falls below 75% of its regulated value, then a short-circuit fault is assumed. A 1.8 $\mu$ A current then begins discharging  $C_{SS}$ . If the fault condition persists until the RUN/SS pin drops to 3.5V, then the controller turns off both power MOSFETs, shutting down the converter permanently. The RUN/SS pin must be actively pulled down to ground in order to restart operation.

The overcurrent protection timer requires that the soft-start timing capacitor  $C_{SS}$  be made large enough to guarantee that the output is in regulation by the time  $C_{SS}$  has reached the 4V threshold. In general, this will depend upon the size of the output capacitance, output voltage and load current characteristic. A minimum soft-start capacitor can be estimated from:

$$C_{SS} > C_{OUT} V_{OUT} R_{SENSE} (10^{-4} [F/V s])$$

Generally 0.1 $\mu$ F is more than sufficient.

Overcurrent latching operation is not always needed or desired. The feature can be overridden by adding a pull-up current greater than 5 $\mu$ A to the RUN/SS pin. The additional current prevents the discharge of  $C_{SS}$  during a fault and also shortens the soft-start period. Using a resistor to  $V_{IN}$  as shown in Figure 6a is simple, but slightly increases shutdown current. Connecting a resistor to  $INTV_{CC}$  as shown in Figure 6b eliminates the additional shutdown current, but requires a diode to isolate  $C_{SS}$ . Any pull-up network must be able to pull RUN/SS above the 4.2V maximum threshold of the latching circuit and overcome the 4 $\mu$ A maximum discharge current.

### INTV<sub>CC</sub> Regulator

An internal P-channel low dropout regulator produces the 5V supply that powers the drivers and internal circuitry within the LTC3717-1. The  $INTV_{CC}$  pin can supply up to 50mA RMS and must be bypassed to ground with a minimum of 4.7 $\mu$ F tantalum or other low ESR capacitor. Good bypassing is necessary to supply the high transient currents required by the MOSFET gate drivers. Applications using large MOSFETs with a high input voltage and

high frequency of operation may cause the LTC3717-1 to exceed its maximum junction temperature rating or RMS current rating. Most of the supply current drives the MOSFET gates unless an external  $EXTV_{CC}$  source is used. In continuous mode operation, this current is  $I_{GATECHG} = f(Q_{g(TOP)} + Q_{g(BOT)})$ . The junction temperature can be estimated from the equations given in Note 2 of the Electrical Characteristics. For example, the LTC3717EUH-1 is limited to less than 14mA from a 30V supply:

$$T_J = 70^{\circ}\text{C} + (14\text{mA})(30\text{V})(34^{\circ}\text{C/W}) = 84.3^{\circ}\text{C}$$

For larger currents, consider using an external supply with the  $EXTV_{CC}$  pin.

### EXTV<sub>CC</sub> Connection

The  $EXTV_{CC}$  pin can be used to provide MOSFET gate drive and control power from the output or another external source during normal operation. Whenever the  $EXTV_{CC}$  pin is above 4.7V the internal 5V regulator is shut off and an internal 50mA P-channel switch connects the  $EXTV_{CC}$  pin to  $INTV_{CC}$ .  $INTV_{CC}$  power is supplied from  $EXTV_{CC}$  until this pin drops below 4.5V. Do not apply more than 7V to the  $EXTV_{CC}$  pin and ensure that  $EXTV_{CC} \leq V_{CC}$ . The following list summarizes the possible connections for  $EXTV_{CC}$ :

1.  $EXTV_{CC}$  grounded.  $INTV_{CC}$  is always powered from the internal 5V regulator.
2.  $EXTV_{CC}$  connected to an external supply. A high efficiency supply compatible with the MOSFET gate drive requirements (typically 5V) can improve overall efficiency.
3.  $EXTV_{CC}$  connected to an output derived boost network. The low voltage output can be boosted using a charge pump or flyback winding to greater than 4.7V. The system will start-up using the internal linear regulator until the boosted output supply is available.

### Efficiency Considerations

The percent efficiency of a switching regulator is equal to the output power divided by the input power times 100%. It is often useful to analyze individual losses to determine

## APPLICATIONS INFORMATION

what is limiting the efficiency and which change would produce the most improvement. Although all dissipative elements in the circuit produce losses, four main sources account for most of the losses in LTC3717-1 circuits:

1. DC  $I^2R$  losses. These arise from the resistances of the MOSFETs, inductor and PC board traces and cause the efficiency to drop at high output currents. In continuous mode the average output current flows through L, but is chopped between the top and bottom MOSFETs. If the two MOSFETs have approximately the same  $R_{DS(ON)}$ , then the resistance of one MOSFET can simply be summed with the resistances of L and the board traces to obtain the DC  $I^2R$  loss. For example, if  $R_{DS(ON)} = 0.01\Omega$  and  $R_L = 0.005\Omega$ , the loss will range from 1% up to 10% as the output current varies from 1A to 10A for a 1.5V output.

2. Transition loss. This loss arises from the brief amount of time the top MOSFET spends in the saturated region during switch node transitions. It depends upon the input voltage, load current, driver strength and MOSFET capacitance, among other factors. The loss is significant at input voltages above 20V and can be estimated from:

$$\text{Transition Loss} \cong (1.7A^{-1}) V_{IN}^2 I_{OUT} C_{RSS} f$$

3.  $I_{NTVCC}$  current. This is the sum of the MOSFET driver and control currents.

4.  $C_{IN}$  loss. The input capacitor has the difficult job of filtering the large RMS input current to the regulator. It must have a very low ESR to minimize the AC  $I^2R$  loss and sufficient capacitance to prevent the RMS current from causing additional upstream losses in fuses or batteries.

Other losses, including  $C_{OUT}$  ESR loss, Schottky diode D1 conduction loss during dead time and inductor core loss generally account for less than 2% additional loss.

When making adjustments to improve efficiency, the input current is the best indicator of changes in efficiency. If you make a change and the input current decreases, then the efficiency has increased. If there is no change in input current, then there is no change in efficiency.

### Checking Transient Response

The regulator loop response can be checked by looking at the load transient response. Switching regulators take several cycles to respond to a step in load current. When a load step occurs,  $V_{OUT}$  immediately shifts by an amount equal to  $\Delta I_{LOAD}$  (ESR), where ESR is the effective series resistance of  $C_{OUT}$ .  $\Delta I_{LOAD}$  also begins to charge or discharge  $C_{OUT}$  generating a feedback error signal used by the regulator to return  $V_{OUT}$  to its steady-state value. During this recovery time,  $V_{OUT}$  can be monitored for overshoot or ringing that would indicate a stability problem. The  $I_{TH}$  pin external components shown in Figure 1 will provide adequate compensation for most applications. For a detailed explanation of switching control loop theory see Application Note 76.

### Design Example

As a design example, take a supply with the following specifications:  $V_{IN} = V_{REF} = 2.5V$ ,  $V_{EXTVCC} = 5V$ ,  $V_{OUT} = 1.25V \pm 5\%$ ,  $I_{OUT(MAX)} = 10A$ ,  $f = 250kHz$ . First, calculate the timing resistor with  $V_{ON} = V_{OUT}$ :

$$R_{ON} = \frac{1.25V(2.5V - 0.7V)}{(0.7V)(250kHz)(10pF)2.5V} = 514k\Omega$$

and choose the inductor for about 40% ripple current at the maximum  $V_{IN}$ :

$$L = \frac{1.25V}{(250kHz)(0.4)(10A)} \left( 1 - \frac{1.25V}{2.5V} \right) = 0.63\mu H$$

Selecting a standard value of 0.68 $\mu H$  results in a maximum ripple current of:

$$\Delta I_L = \frac{1.25V}{(250kHz)(0.68\mu H)} \left( 1 - \frac{1.25V}{2.5V} \right) = 3.7A$$

Next, choose the synchronous MOSFET switch. Choosing a Si4874 ( $R_{DS(ON)} = 0.0083\Omega$  (NOM) 0.010 $\Omega$  (MAX),  $\theta_{JA} = 40^\circ C/W$ ) yields a nominal sense voltage of:

$$V_{SNS(NOM)} = (10A)(1.3)(0.0083\Omega) = 108mV$$

## APPLICATIONS INFORMATION

Tying  $V_{RNG}$  to 1.1V will set the current sense voltage range for a nominal value of 110mV with current limit occurring at 143mV. To check if the current limit is acceptable, assume a junction temperature of about 40°C above a 70°C ambient with  $p_{110^\circ C} = 1.4$ :

$$I_{LIMIT} \geq \frac{143mV}{(1.4)(0.010\Omega)} + \frac{1}{2}(3.7A) = 12.1A$$

and double check the assumed  $T_J$  in the MOSFET:

$$P_{BOT} = \frac{2.5V - 1.25V}{2.5V} (12.1A)^2 (1.4)(0.010\Omega) = 1.02W$$

$$T_J = 70^\circ C + (1.02W)(40^\circ C/W) = 111^\circ C$$

Because the top MOSFET is on roughly the same amount of time as the bottom MOSFET, the same Si4874 can be used as the synchronous MOSFET.

The junction temperatures will be significantly less at nominal current, but this analysis shows that careful attention to heat sinking will be necessary in this circuit.

$C_{IN}$  is chosen for an RMS current rating of about 5A at 85°C. The output capacitors are chosen for a low ESR of

0.013Ω to minimize output voltage changes due to inductor ripple current and load steps. For current sinking applications where current flows back to the input through the top transistor, output capacitors with a similar amount of bulk C and ESR should be placed on the input as well. (This is typically the case, since  $V_{IN}$  is derived from another DC/DC converter.) The ripple voltage will be only:

$$\begin{aligned} \Delta V_{OUT(RIPPLE)} &= \Delta I_{L(MAX)} (ESR) \\ &= (4A) (0.013\Omega) = 52mV \end{aligned}$$

However, a 0A to 10A load step will cause an output change of up to:

$$\Delta V_{OUT(STEP)} = \Delta I_{LOAD} (ESR) = (10A) (0.013\Omega) = 130mV$$

An optional 22μF ceramic output capacitor is included to minimize the effect of ESL in the output ripple. The complete circuit is shown in Figure 7.

### PC Board Layout Checklist

When laying out a PC board follow one of the two suggested approaches. The simple PC board layout requires a dedicated ground plane layer. Also, for higher currents, it is recommended to use a multilayer board to help with heat sinking power components.

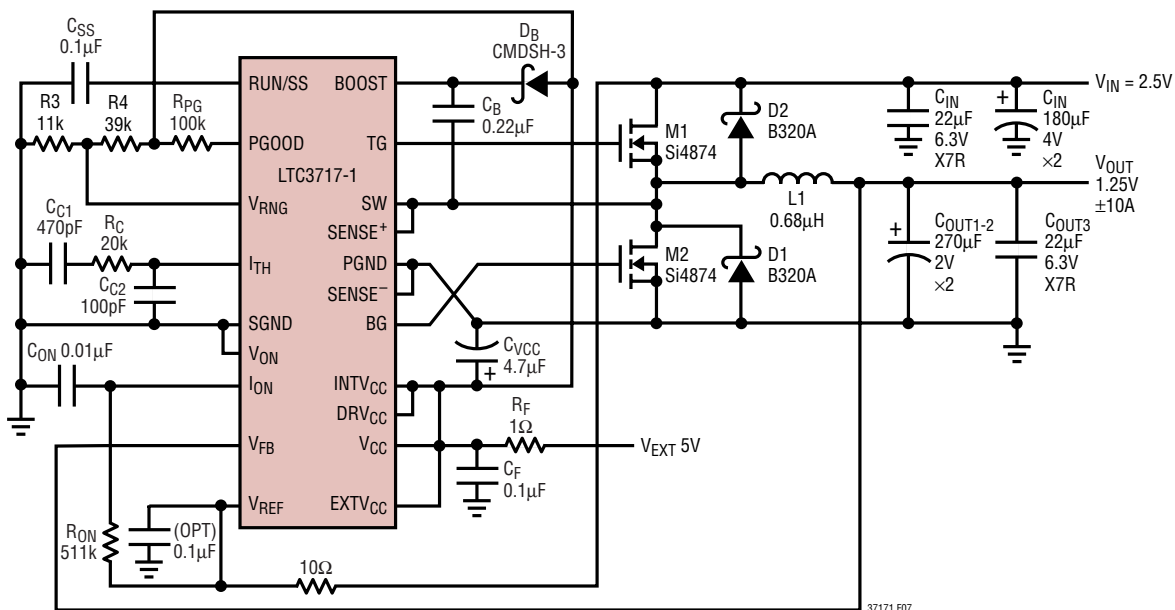

$C_{IN}$ ,  $C_{OUT1-2}$ : CORNELL DUBILIER ESRE181E04B  
L1: SUMIDA CEP125-0R68MC-H

Figure 7. Design Example: 1.25V/±10A at 250kHz

## APPLICATIONS INFORMATION

- The ground plane layer should not have any traces and it should be as close as possible to the layer with power MOSFETs.
  - Place  $C_{IN}$ ,  $C_{OUT}$ , MOSFETs, D1 and inductor all in one compact area. It may help to have some components on the bottom side of the board.
  - Place LTC3717-1 chip with Pins 15 to 28 facing the power components. Keep the components connected to Pins 1 to 10 close to LTC3717-1 (noise sensitive components).
  - Use an immediate via to connect the components to ground plane including SGND and PGND of LTC3717-1. Use several bigger vias for power components.
  - Use compact plane for switch node (SW) to improve cooling of the MOSFETs and to keep EMI down.
  - Use planes for  $V_{IN}$  and  $V_{OUT}$  to maintain good voltage filtering and to keep power losses low.
  - Flood all unused areas on all layers with copper. Flooding with copper will reduce the temperature rise of power component. You can connect the copper areas to any DC net ( $V_{IN}$ ,  $V_{OUT}$ , GND or to any other DC rail in your system).
- When laying out a printed circuit board, without a ground plane, use the following checklist to ensure proper operation of the controller. These items are also illustrated in Figure 8.
- Segregate the signal and power grounds. All small signal components should return to the SGND pin at one point which is then tied to the PGND pin close to the source of M2.
  - Place M2 as close to the controller as possible, keeping the PGND, BG and SW traces short.
  - Connect the input capacitor(s)  $C_{IN}$  close to the power MOSFETs. This capacitor carries the MOSFET AC current.
  - Keep the high dV/dT SW, BOOST and TG nodes away from sensitive small-signal nodes.
  - Connect the INTV<sub>CC</sub> and DRV<sub>CC</sub> decoupling capacitor  $C_{VCC}$  closely to the INTV<sub>CC</sub>, DRV<sub>CC</sub> and PGND pins.
  - Connect the top driver boost capacitor  $C_B$  closely to the BOOST and SW pins.
  - Connect the  $V_{CC}$  pin decoupling capacitor  $C_F$  closely to the  $V_{CC}$  and PGND pins.

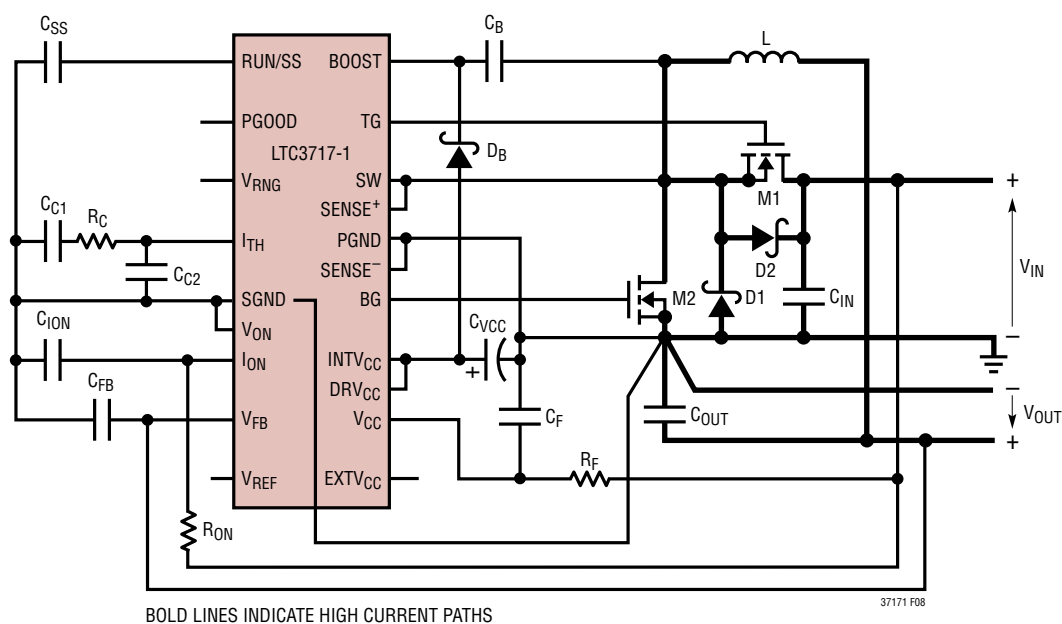
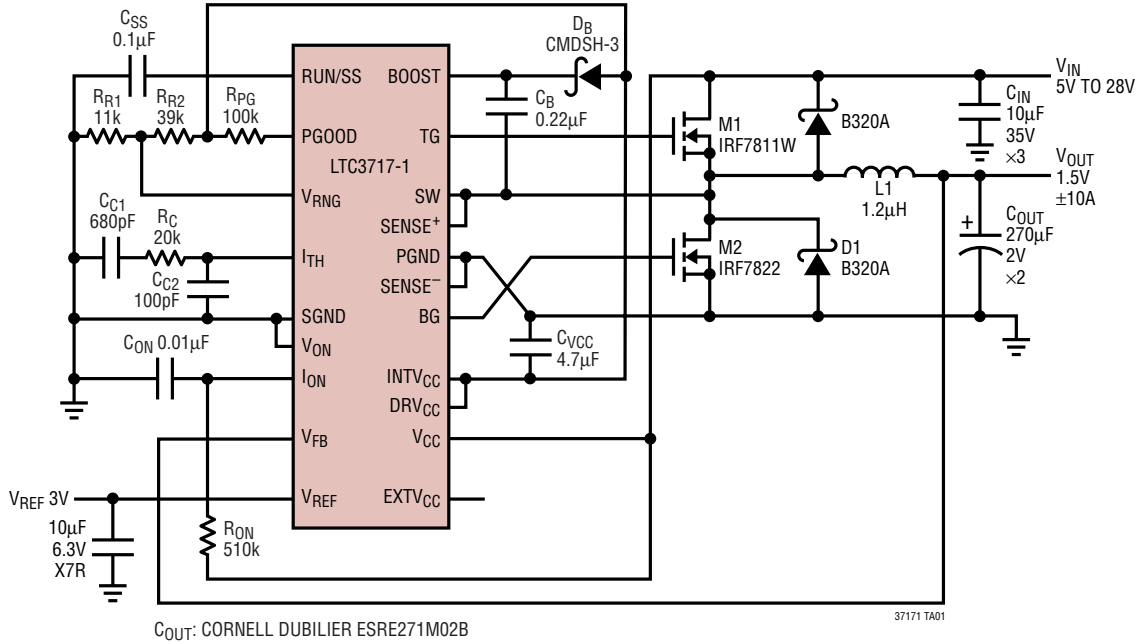

Figure 8. LTC3717-1 Layout Diagram

TYPICAL APPLICATIONS

1.5V±10A at 300kHz from 5V to 28V Input



High Voltage Half (V<sub>IN</sub>) Power Supply

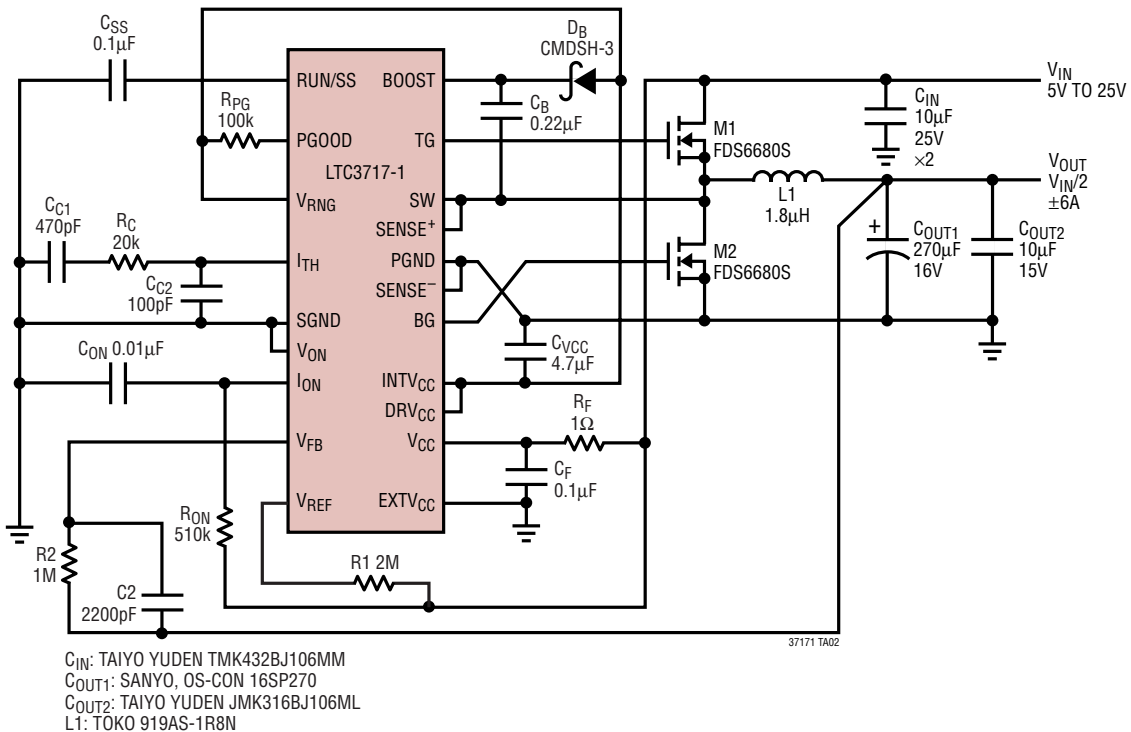

# PACKAGE DESCRIPTION

**UH Package**  
**32-Lead Plastic QFN (5mm × 5mm)**  
 (Reference LTC DWG # 05-08-1693)

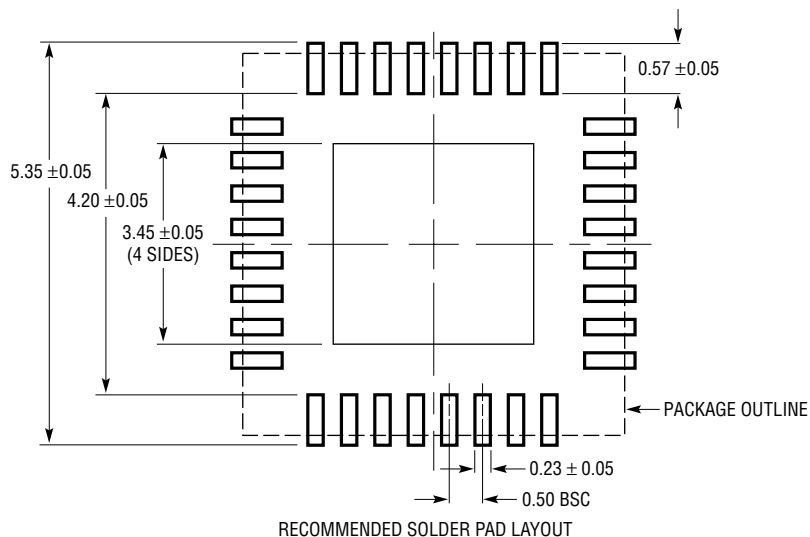

RECOMMENDED SOLDER PAD LAYOUT

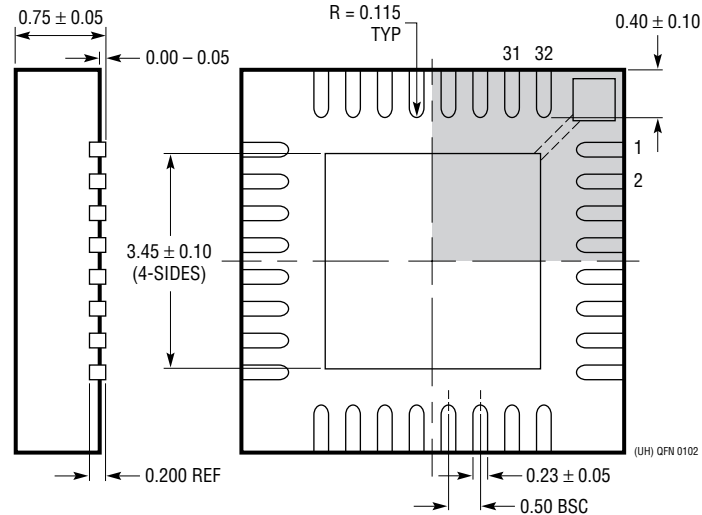
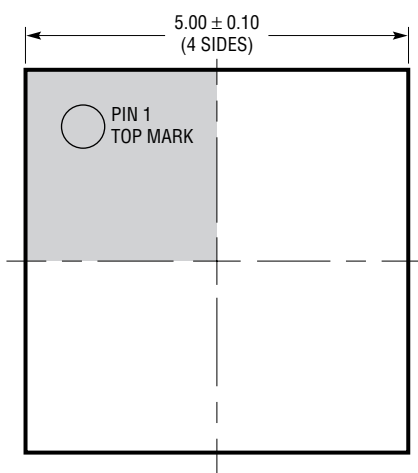

- NOTE:
1. DRAWING PROPOSED TO BE A JEDEC PACKAGE OUTLINE MO-220 VARIATION WHHD-(X) (TO BE APPROVED)
  2. DRAWING NOT TO SCALE
  3. ALL DIMENSIONS ARE IN MILLIMETERS
  4. DIMENSIONS OF EXPOSED PAD ON BOTTOM OF PACKAGE DO NOT INCLUDE MOLD FLASH. MOLD FLASH, IF PRESENT, SHALL NOT EXCEED 0.20mm ON ANY SIDE
  5. EXPOSED PAD SHALL BE SOLDER PLATED

## TYPICAL APPLICATION

Typical Application 1.25V/±3A at 1.4MHz

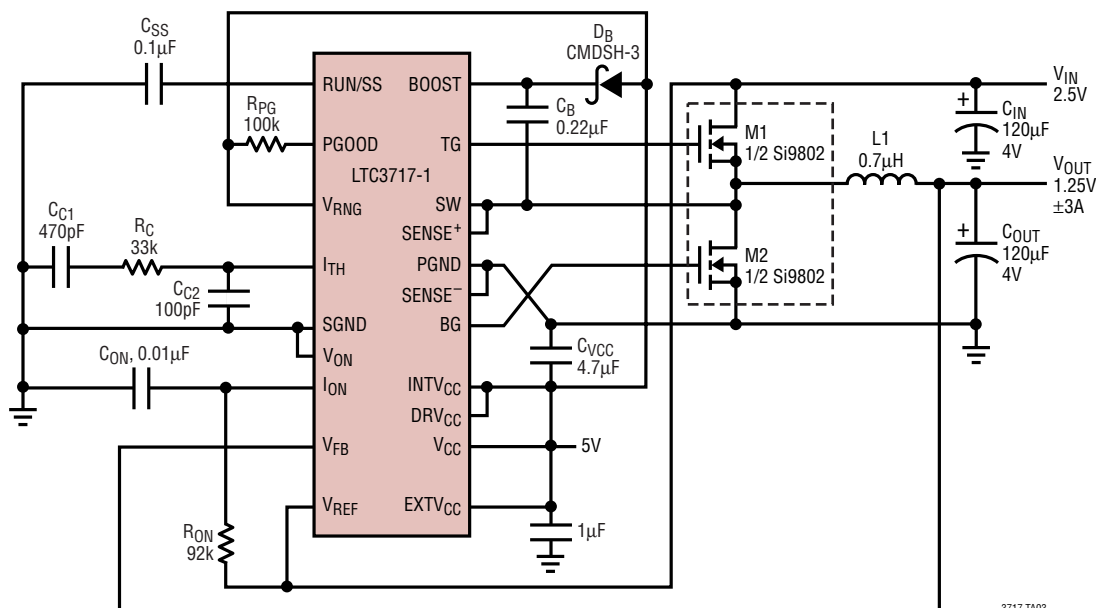

C<sub>IN</sub>, C<sub>OUT</sub>: CORNELL DUBILIER ESRD121M04B  
L1: TOKO A921CY-0R7M

3717 TA03

## RELATED PARTS

PART NUMBER	DESCRIPTION	COMMENTS
LTC1625/LTC1775	No R <sub>SENSE</sub> <sup>TM</sup> Current Mode Synchronous Step-Down Controller	97% Efficiency; No Sense Resistor; 99% Duty Cycle
LTC1628-PG	Dual, 2-Phase Synchronous Step-Down Controller	Power Good Output; Minimum Input/Output Capacitors; 3.5V ≤ V <sub>IN</sub> ≤ 36V
LTC1628-SYNC	Dual, 2-Phase Synchronous Step-Down Controller	Synchronizable 150kHz to 300kHz
LTC1709-7	High Efficiency, 2-Phase Synchronous Step-Down Controller with 5-Bit VID	Up to 42A Output; 0.925V ≤ V <sub>OUT</sub> ≤ 2V
LTC1709-8	High Efficiency, 2-Phase Synchronous Step-Down Controller	Up to 42A Output; VRM 8.4; 1.3V ≤ V <sub>OUT</sub> ≤ 3.5V
LTC1735	High Efficiency, Synchronous Step-Down Controller	Burst Mode <sup>TM</sup> Operation; 16-Pin Narrow SSOP; 3.5V ≤ V <sub>IN</sub> ≤ 36V
LTC1736	High Efficiency, Synchronous Step-Down Controller with 5-Bit VID	Mobile VID; 0.925V ≤ V <sub>OUT</sub> ≤ 2V; 3.5V ≤ V <sub>IN</sub> ≤ 36V
LTC1772	SOT-23 Step-Down Controller	Current Mode; 550kHz; Very Small Solution Size
LTC1773	Synchronous Step-Down Controller	Up to 95% Efficiency, 550kHz, 2.65V ≤ V <sub>IN</sub> ≤ 8.5V, 0.8V ≤ V <sub>OUT</sub> ≤ V <sub>IN</sub> , Synchronizable to 750kHz
LTC1778/LTC3778	Wide Operating Range, No R <sub>SENSE</sub> Step-Down Synchronous Controllers	4V ≤ V <sub>IN</sub> ≤ 36V, True Current Mode Control, 2% to 90% Duty Cycle
LTC1874	Dual, Step-Down Controller	Current Mode; 550kHz; Small 16-Pin SSOP, V <sub>IN</sub> < 9.8V
LTC1876	2-Phase, Dual Synchronous Step-Down Controller with Step-Up Regulator	2.6V ≤ V <sub>IN</sub> ≤ 36V, Power Good Output, 300kHz Operation
LTC3413	Monolithic DDR Memory Termination Regulator	90% Efficiency, ±3A Output, 2MHz Operation
LTC3717	Wide Operating Range, No R <sub>SENSE</sub> Step-Down Synchronous Controllers for DDR Memory Termination	4V ≤ V <sub>IN</sub> ≤ 36V, True Current Mode Control, 2% to 90% Duty Cycle, 16-Pin SSOP, No R <sub>SENSE</sub>

Burst Mode is a registered trademark of Linear Technology Corporation.

sn37171 37171fs

## Looking for pricing, stock, or lifecycle information?

Click below to explore more details on WIN SOURCE:

 [View LTC3717EUH-1#TRPBF on WIN SOURCE](#)

 [Linear Technology](#) Information

## Optimize Your Supply Chain with WIN SOURCE Solutions

-  Global Sourcing Solution
-  Obsolete Management
-  Cost Control Management
-  Shortage Management
-  Alternative Solution
-  Excess Inventory Management