



**THE DATASHEET OF  
LTC3788EUH#PBF**



# 2-Phase, Dual Output Synchronous Boost Controller

## FEATURES

- Synchronous Operation for Highest Efficiency and Reduced Heat Dissipation
- Wide Input Range: 4.5V to 38V (40V Abs Max) and Operates Down to 2.5V After Start-Up
- Output Voltages Up to 60V
- $\pm 1\%$  1.2V Reference Voltage
- $R_{SENSE}$  or Inductor DCR Current Sensing
- 100% Duty Cycle Capability for Synchronous MOSFET
- Low Quiescent Current: 125 $\mu$ A
- Phase-Lockable Frequency (75kHz to 850kHz)
- Programmable Fixed Frequency (50kHz to 900kHz)
- Selectable Current Limit
- Adjustable Output Voltage Soft-Start
- Power Good Output Voltage Monitors
- Low Shutdown Current  $I_Q$ : < 8 $\mu$ A
- Internal LDO Powers Gate Drive from VBIAS or EXT $V_{CC}$
- Thermally Enhanced Low Profile 32-Pin 5mm x 5mm QFN Package

## APPLICATIONS

- Industrial
- Automotive
- Medical
- Military

## DESCRIPTION

The LTC<sup>®</sup>3788 is a high performance 2-phase dual synchronous boost converter controller that drives all N-channel power MOSFETs. Synchronous rectification increases efficiency, reduces power losses and eases thermal requirements, allowing the LTC3788 to be used in high power boost applications.

A constant-frequency current mode architecture allows a phase-lockable frequency of up to 850kHz. OPTI-LOOP<sup>®</sup> compensation allows the transient response to be optimized over a wide range of output capacitance and ESR values. The LTC3788 features a precision 1.2V reference and dual power good output indicators. A 4.5V to 38V input supply range encompasses a wide range of system architectures and battery chemistries.

Independent SS pins for each controller ramp the output voltages during start-up. The PLLIN/MODE pin selects among Burst Mode<sup>®</sup> operation, pulse-skipping mode or continuous inductor current mode at light loads.

For a leaded 28-lead SSOP package with a fixed current limit and one PGOOD output, without phase modulation or a clock output, see the LTC3788-1 data sheet.

LT, LT, LTC, LTM, Linear Technology, Burst Mode, OPTI-LOOP, PolyPhase and the Linear logo are registered trademarks and No  $R_{SENSE}$  and ThinSOT are trademarks of Linear Technology Corporation. All other trademarks are the property of their respective owners. Protected by U. S. Patents, including 5408150, 5481178, 5705919, 5929620, 6144194, 6177787, 6580258.

## TYPICAL APPLICATION

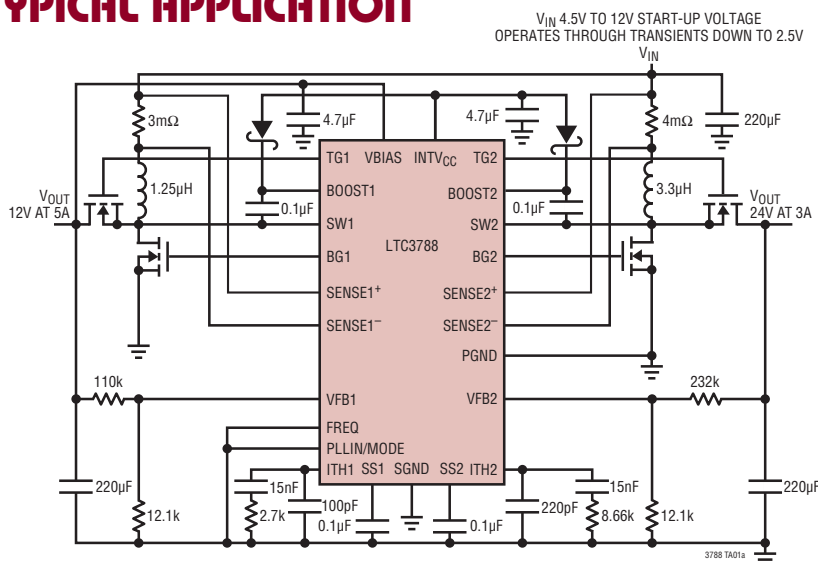

**Efficiency and Power Loss vs Output Current**

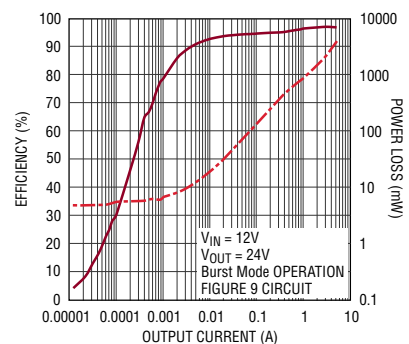

# LTC3788

## ABSOLUTE MAXIMUM RATINGS

(Notes 1, 3)

VBIAS .....	-0.3V to 40V
BOOST1, BOOST2 .....	-0.3V to 76V
SW1, SW2 .....	-0.3V to 70V
RUN1, RUN2 .....	-0.3V to 8V
Maximum Current Sourced into Pin from Source > 8V .....	100 $\mu$ A
PGOOD1, PGOOD2, PLLIN/MODE .....	-0.3V to 6V
INTV <sub>CC</sub> , (BOOST1-SW1, BOOST2-SW2) .....	-0.3V to 6V
EXTV <sub>CC</sub> .....	-0.3V to 6V
SENSE1 <sup>+</sup> , SENSE1 <sup>-</sup> , SENSE2 <sup>+</sup> , SENSE2 <sup>-</sup> .....	-0.3V to 40V
SENSE1 <sup>+</sup> – SENSE1 <sup>-</sup> , SENSE2 <sup>+</sup> – SENSE2 <sup>-</sup> .....	-0.3V to 0.3V
I <sub>LIM</sub> , SS1, SS2, ITH1, ITH2, FREQ, PHASMD, VFB1, VFB2 .....	-0.3V to INTV <sub>CC</sub>
Operating Junction Temperature Range .....	-40°C to 125°C
Storage Temperature Range .....	-65°C to 125°C

## PIN CONFIGURATION

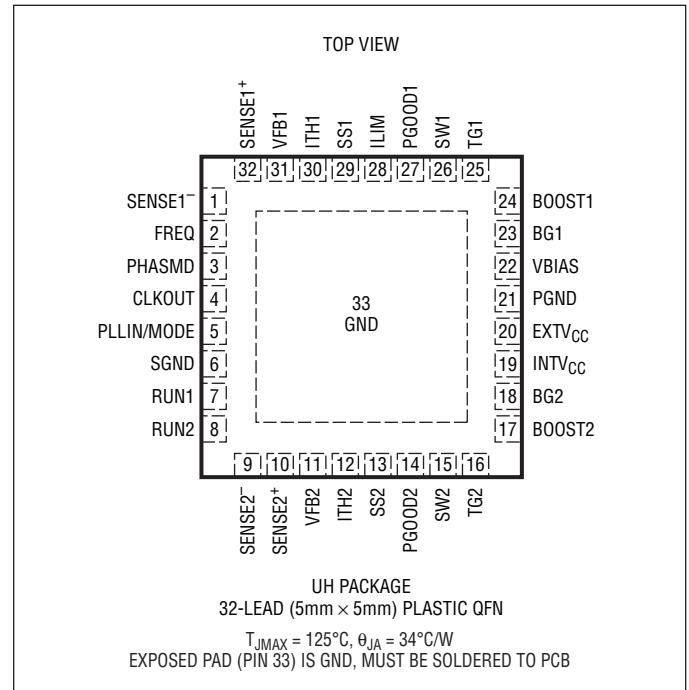

## ORDER INFORMATION

LEAD FREE FINISH	TAPE AND REEL	PART MARKING*	PACKAGE DESCRIPTION	TEMPERATURE RANGE
LTC3788EUH#PBF	LTC3788EUH#TRPBF	3788	32-Lead (5mm×5mm) Plastic QFN	-40°C to 125°C
LTC3788IUH#PBF	LTC3788IUH#TRPBF	3788	32-Lead (5mm×5mm) Plastic QFN	-40°C to 125°C

Consult LTC Marketing for parts specified with wider operating temperature ranges. \*The temperature grade is identified by a label on the shipping container. Consult LTC Marketing for information on non-standard lead based finish parts.

For more information on lead free part marking, go to: <http://www.linear.com/leadfree/>

For more information on tape and reel specifications, go to: <http://www.linear.com/tapeandreeel/>

## ELECTRICAL CHARACTERISTICS

The ● denotes the specifications which apply over the full operating junction temperature range, otherwise specifications are at T<sub>A</sub> = 25°C, VBIAS = 12V, unless otherwise noted (Note 2).

SYMBOL	PARAMETER	CONDITIONS	MIN	TYP	MAX	UNITS
<b>Main Control Loop</b>						
VBIAS	Chip Bias Voltage Operating Range		4.5		38	V
V <sub>FB1,2</sub>	Regulated Feedback Voltage	I <sub>TH</sub> = 1.2V (Note 4)	● 1.188	1.200	1.212	V
I <sub>FB1,2</sub>	Feedback Current	(Note 4)		±5	±50	nA
V <sub>REFLNREG</sub>	Reference Line Voltage Regulation	VBIAS = 6V to 38V		0.002	0.02	%/V

3788fc

## ELECTRICAL CHARACTERISTICS

The ● denotes the specifications which apply over the full operating junction temperature range, otherwise specifications are at  $T_A = 25^\circ\text{C}$ ,  $V_{\text{BIAS}} = 12\text{V}$ , unless otherwise noted (Note 2).

SYMBOL	PARAMETER	CONDITIONS	MIN	TYP	MAX	UNITS	
$V_{\text{LOADREG}}$	Output Voltage Load Regulation	(Note 4)					
		Measured in Servo Loop; $\Delta I_{\text{TH}}$ Voltage = 1.2V to 0.7V	●	0.01	0.1	%	
		Measured in Servo Loop; $\Delta I_{\text{TH}}$ Voltage = 1.2V to 2V	●	-0.01	-0.1	%	
$g_{m1,2}$	Error Amplifier Transconductance	$I_{\text{TH}} = 1.2\text{V}$		2		mmho	
$I_{\text{Q}}$	Input DC Supply Current	(Note 5)					
	Pulse-Skipping or Forced Continuous Mode (One Channel On)	$\text{RUN1} = 5\text{V}$ and $\text{RUN2} = 0\text{V}$ or $\text{RUN1} = 0\text{V}$ and $\text{RUN2} = 5\text{V}$ ; $V_{\text{FB1}(2)} = 1.25\text{V}$ (No Load)		0.9		mA	
	Pulse-Skipping or Forced Continuous Mode (Both Channels On)	$\text{RUN1,2} = 5\text{V}$ ; $V_{\text{FB1,2}} = 1.25\text{V}$ (No Load)		1.2		mA	
	Sleep Mode (One Channel On)	$\text{RUN1} = 5\text{V}$ and $\text{RUN2} = 0\text{V}$ or $\text{RUN1} = 0\text{V}$ and $\text{RUN2} = 5\text{V}$ ; $V_{\text{FB1}(2)} = 1.25\text{V}$ (No Load)		125	190	$\mu\text{A}$	
	Sleep Mode (Both Channels On)	$\text{RUN1,2} = 5\text{V}$ ; $V_{\text{FB1,2}} = 1.25\text{V}$ (No Load)		200	300	$\mu\text{A}$	
	Shutdown	$\text{RUN1,2} = 0\text{V}$		8	20	$\mu\text{A}$	
UVLO	INTV <sub>CC</sub> Undervoltage Lockout Thresholds	$V_{\text{INTVCC}}$ Ramping Up	●	4.1	4.3	V	
		$V_{\text{INTVCC}}$ Ramping Down	●	3.6	3.8	V	
$V_{\text{RUN1,2}}$	RUN Pin On Threshold	$V_{\text{RUN}}$ Rising	●	1.18	1.28	1.38	V
$V_{\text{RUNHYS}}$	RUN Pin Hysteresis			100		mV	
$I_{\text{RUN1,2}}$	RUN Pin Hysteresis Current	$V_{\text{RUN}} > 1.28\text{V}$		4.5		$\mu\text{A}$	
$I_{\text{RUN1,2}}$	RUN Pin Current	$V_{\text{RUN}} < 1.28\text{V}$		0.5		$\mu\text{A}$	
$I_{\text{SS1,2}}$	Soft-Start Charge Current	$V_{\text{SS}} = \text{GND}$		7	10	13	$\mu\text{A}$
$V_{\text{SENSE(MAX)}}$	Maximum Current Sense Threshold	$V_{\text{FB}} = 1.1\text{V}$ , $I_{\text{LIM}} = \text{INTV}_{\text{CC}}$	●	90	100	110	mV
		$V_{\text{FB}} = 1.1\text{V}$ , $I_{\text{LIM}} = \text{Float}$	●	68	75	82	mV
		$V_{\text{FB}} = 1.1\text{V}$ , $I_{\text{LIM}} = \text{GND}$	●	42	50	56	mV
$V_{\text{SENSE(CM)}}$	SENSE Pins Common Mode Range (BOOST Converter Input Supply Voltage $V_{\text{IN}}$ )			2.5	38	V	
$I_{\text{SENSE1,2}^+}$	SENSE <sup>+</sup> Pin Current	$V_{\text{FB}} = 1.1\text{V}$ , $I_{\text{LIM}} = \text{Float}$		200	300	$\mu\text{A}$	
$I_{\text{SENSE1,2}^-}$	SENSE <sup>-</sup> Pin Current	$V_{\text{FB}} = 1.1\text{V}$ , $I_{\text{LIM}} = \text{Float}$			±1	$\mu\text{A}$	
$t_{\text{r(TG1,2)}}$	Top Gate Rise Time	$C_{\text{LOAD}} = 3300\text{pF}$ (Note 6)		20		ns	
$t_{\text{f(TG1,2)}}$	Top Gate Fall Time	$C_{\text{LOAD}} = 3300\text{pF}$ (Note 6)		20		ns	
$t_{\text{r(BG1,2)}}$	Bottom Gate Rise Time	$C_{\text{LOAD}} = 3300\text{pF}$ (Note 6)		20		ns	
$t_{\text{f(BG1,2)}}$	Bottom Gate Fall Time	$C_{\text{LOAD}} = 3300\text{pF}$ (Note 6)		20		ns	
$R_{\text{UP(TG1,2)}}$	Top Gate Pull-Up Resistance			1.2		$\Omega$	
$R_{\text{DN(TG1,2)}}$	Top Gate Pull-Down Resistance			1.2		$\Omega$	
$R_{\text{UP(TG1,2)}}$	Bottom Gate Pull-Up Resistance			1.2		$\Omega$	
$R_{\text{DN(TG1,2)}}$	Bottom Gate Pull-Down Resistance			1.2		$\Omega$	
$t_{\text{D(TG/BG)}}$	Top Gate Off to Bottom Gate On Switch-On Delay Time	$C_{\text{LOAD}} = 3300\text{pF}$ (Each Driver)		70		ns	
$t_{\text{D(BG/TG)}}$	Bottom Gate Off to Top Gate On Switch-On Delay Time	$C_{\text{LOAD}} = 3300\text{pF}$ (Each Driver)		70		ns	
$\text{DF}_{\text{MAX(BG1,2)}}$	Maximum BG Duty Factor			96		%	

## ELECTRICAL CHARACTERISTICS

The ● denotes the specifications which apply over the full operating junction temperature range, otherwise specifications are at  $T_A = 25^\circ\text{C}$ ,  $V_{\text{BIAS}} = 12\text{V}$ , unless otherwise noted (Note 2).

SYMBOL	PARAMETER	CONDITIONS	MIN	TYP	MAX	UNITS
$t_{\text{ON(MIN)}}$	Minimum BG On-Time	(Note 7)		110		ns
<b>INTV<sub>CC</sub> Linear Regulator</b>						
$V_{\text{INTVCCVIN}}$	Internal V <sub>CC</sub> Voltage	$6\text{V} < V_{\text{BIAS}} < 38\text{V}$ , $V_{\text{EXTVCC}} = 0\text{V}$	5.2	5.4	5.6	V
$V_{\text{LDOVIN}}$	INTV <sub>CC</sub> Load Regulation	$I_{\text{CC}} = 0\text{mA}$ to $50\text{mA}$ , $V_{\text{EXTVCC}} = 0\text{V}$		0.5	2	%
$V_{\text{INTVCCEXT}}$	Internal V <sub>CC</sub> Voltage	$V_{\text{EXTVCC}} = 6\text{V}$	5.2	5.4	5.6	V
$V_{\text{LDOEXT}}$	INTV <sub>CC</sub> Load Regulation	$I_{\text{CC}} = 0\text{mA}$ to $40\text{mA}$ , $V_{\text{EXTVCC}} = 6\text{V}$		0.5	2	%
$V_{\text{EXTVCC}}$	EXTV <sub>CC</sub> Switchover Voltage	EXTV <sub>CC</sub> Ramping Positive	4.5	4.8	5	V
$V_{\text{LDOHYS}}$	EXTV <sub>CC</sub> Hysteresis			250		mV
<b>Oscillator and Phase-Locked Loop</b>						
$f_{\text{PROG}}$	Programmable Frequency	$R_{\text{FREQ}} = 25\text{k}$		105		kHz
		$R_{\text{FREQ}} = 60\text{k}$	335	400	465	kHz
		$R_{\text{FREQ}} = 100\text{k}$		760		kHz
$f_{\text{LOW}}$	Lowest Fixed Frequency	$V_{\text{FREQ}} = 0\text{V}$	320	350	380	kHz
$f_{\text{HIGH}}$	Highest Fixed Frequency	$V_{\text{FREQ}} = \text{INTV}_{\text{CC}}$	485	535	585	kHz
$f_{\text{SYNC}}$	Synchronizable Frequency	PLLIN/MODE = External Clock	● 75		850	kHz
<b>PGOOD1 and PGOOD2 Outputs</b>						
$V_{\text{PGL}}$	PGOOD Voltage Low	$I_{\text{PGOOD}} = 2\text{mA}$		0.2	0.4	V
$I_{\text{PGOOD}}$	PGOOD Leakage Current	$V_{\text{PGOOD}} = 5\text{V}$			±1	μA
$V_{\text{PG}}$	PGOOD Trip Level	$V_{\text{FB}}$ with Respect to Set Regulated Voltage				
		$V_{\text{FB}}$ Ramping Negative	-12	-10	-8	%
		Hysteresis		2.5		%
		$V_{\text{FB}}$ Ramping Positive	8	10	12	%
		Hysteresis		2.5		%
$t_{\text{PGOOD(DELAY)}}$	PGOOD Delay	PGOOD Going High to Low		25		μs
<b>BOOST1 and BOOST2 Charge Pump</b>						
$I_{\text{BOOST1,2}}$	BOOST Charge Pump Available Output Current	$V_{\text{SW1,2}} = 12\text{V}$ ; $V_{\text{BOOST1,2}} - V_{\text{SW1,2}} = 4.5\text{V}$ ; $\text{FREQ} = 0\text{V}$ , Forced Continuous or Pulse-Skipping Mode		55		μA

**Note 1:** Stresses beyond those listed under Absolute Maximum Ratings may cause permanent damage to the device. Exposure to any Absolute Maximum Rating condition for extended periods may affect device reliability and lifetime.

**Note 2:** The LTC3788 is tested under pulsed load conditions such that  $T_J \approx T_A$ . The LTC3788E is guaranteed to meet specifications from  $0^\circ\text{C}$  to  $85^\circ\text{C}$  junction temperature. Specifications over the  $-40^\circ\text{C}$  to  $125^\circ\text{C}$  operating junction temperature range are assured by design, characterization and correlation with statistical process controls. The LTC3788I is guaranteed over the  $-40^\circ\text{C}$  to  $125^\circ\text{C}$  operating junction temperature range. Note that the maximum ambient temperature consistent with these specifications is determined by specific operating conditions in conjunction with board layout, the rated package thermal impedance and other environmental factors. The junction temperature ( $T_J$ , in  $^\circ\text{C}$ ) is calculated from the ambient temperature ( $T_A$ , in  $^\circ\text{C}$ ) and power dissipation ( $P_D$ , in Watts) according to the formula:  $T_J = T_A + (P_D \cdot \theta_{JA})$ , where  $\theta_{JA} = 34^\circ\text{C/W}$ .

**Note 3:** This IC includes overtemperature protection that is intended to protect the device during momentary overload conditions. The maximum rated junction temperature will be exceeded when this protection is active. Continuous operation above the specified absolute maximum operating junction temperature may impair device reliability or permanently damage the device.

**Note 4:** The LTC3788 is tested in a feedback loop that servos  $V_{\text{FB}}$  to the output of the error amplifier while maintaining  $I_{\text{TH}}$  at the midpoint of the current limit range.

**Note 5:** Dynamic supply current is higher due to the gate charge being delivered at the switching frequency.

**Note 6:** Rise and fall times are measured using 10% and 90% levels. Delay times are measured using 50% levels.

**Note 7:** See Minimum On-Time Considerations in the Applications Information section.

# TYPICAL PERFORMANCE CHARACTERISTICS

**Efficiency and Power Loss vs Output Current**

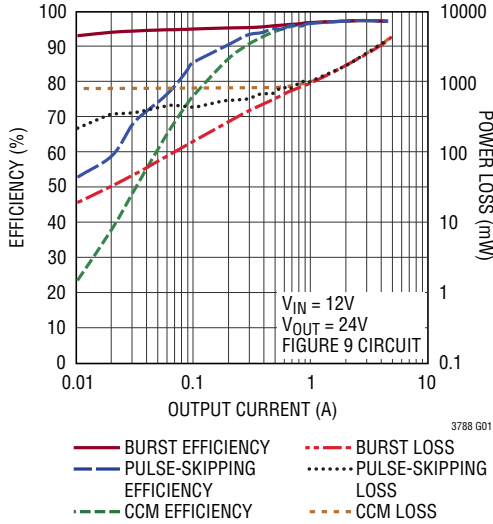

**Efficiency and Power Loss vs Output Current**

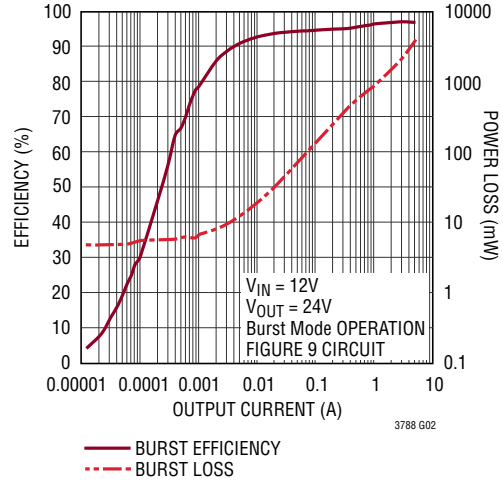

**Efficiency vs Input Voltage**

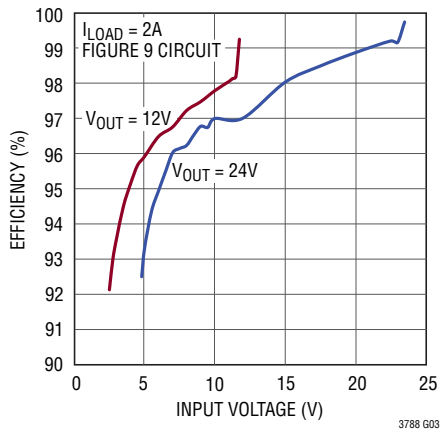

**Load Step  
Forced Continuous Mode**

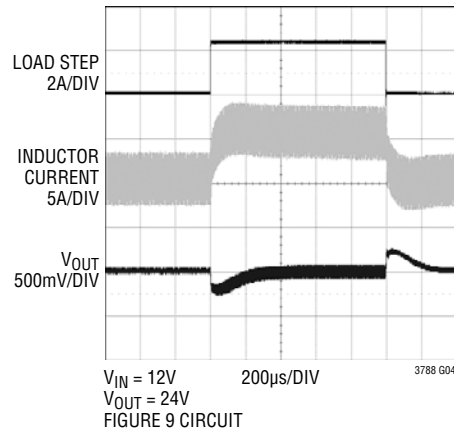

**Load Step  
Burst Mode Operation**

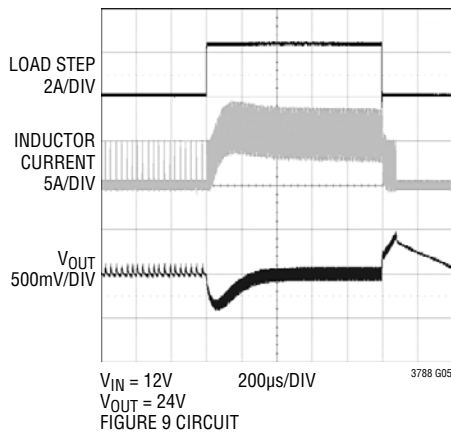

**Load Step  
Pulse-Skipping Mode**

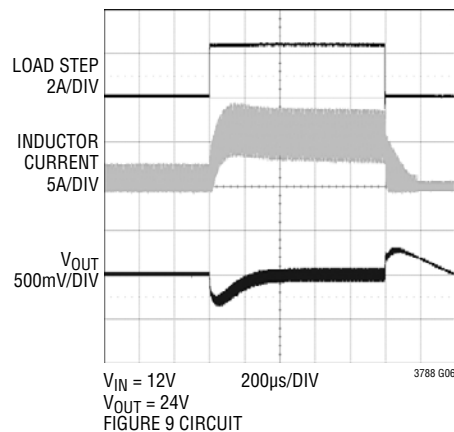

## TYPICAL PERFORMANCE CHARACTERISTICS

**Inductor Current at Light Load**

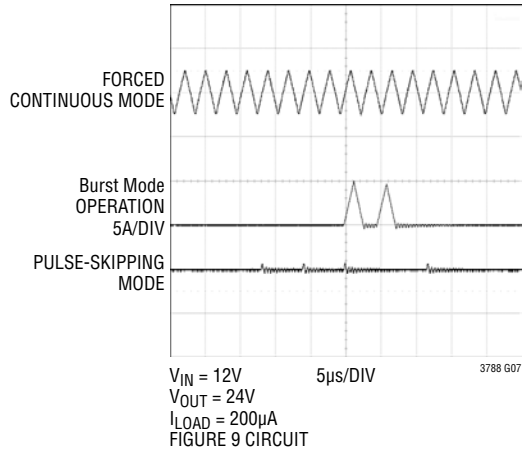

**Soft Start-Up**

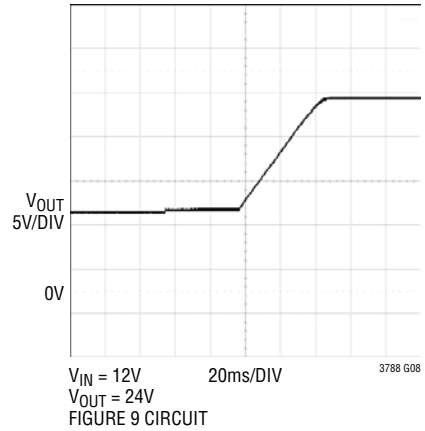

**Regulated Feedback Voltage vs Temperature**

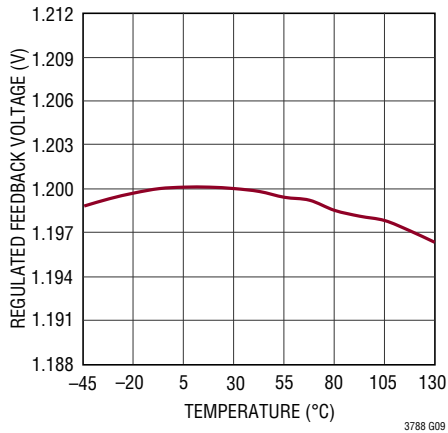

**Soft-Start Pull-Up Current vs Temperature**

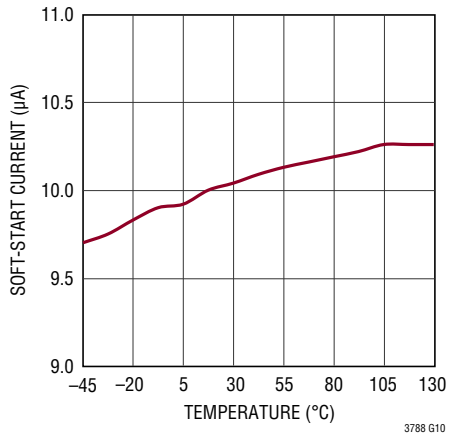

**Shutdown Current vs Temperature**

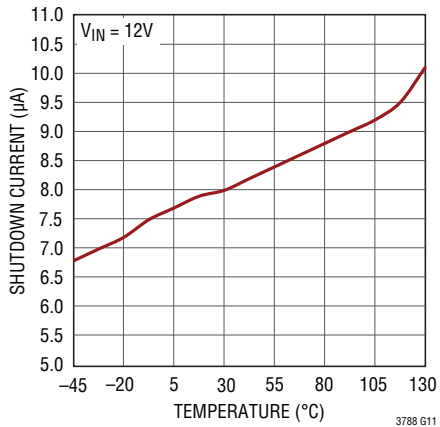

**Shutdown Current vs Input Voltage**

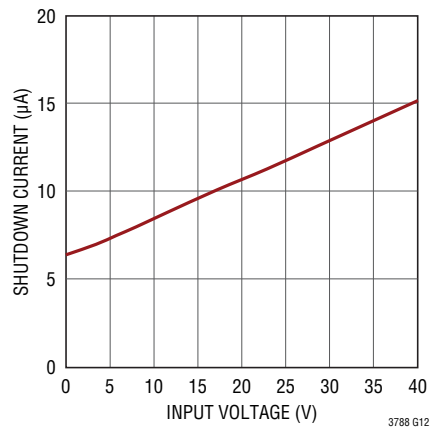

# TYPICAL PERFORMANCE CHARACTERISTICS

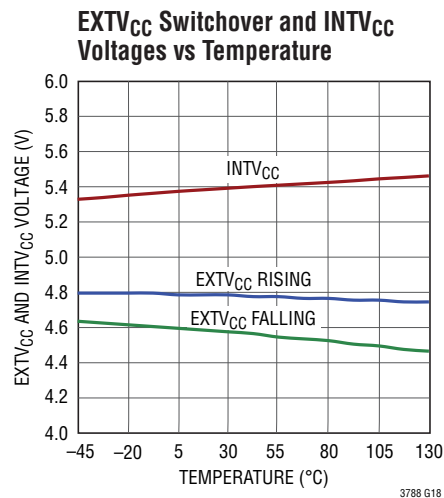
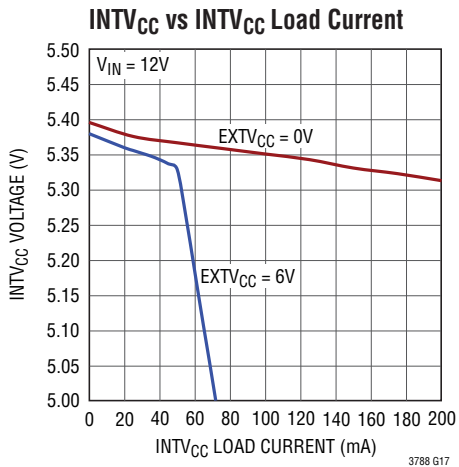
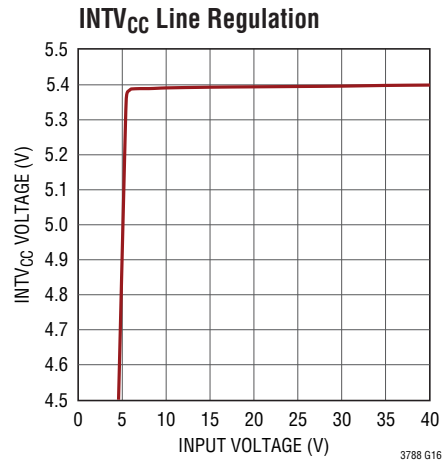
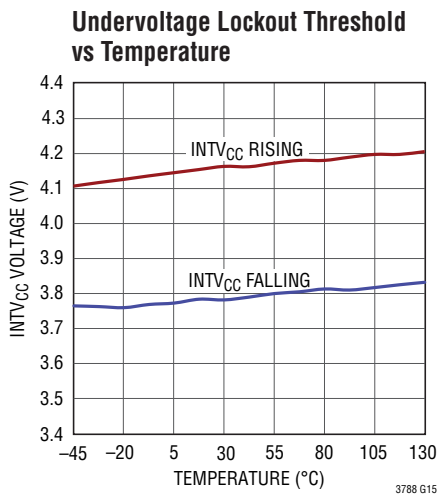
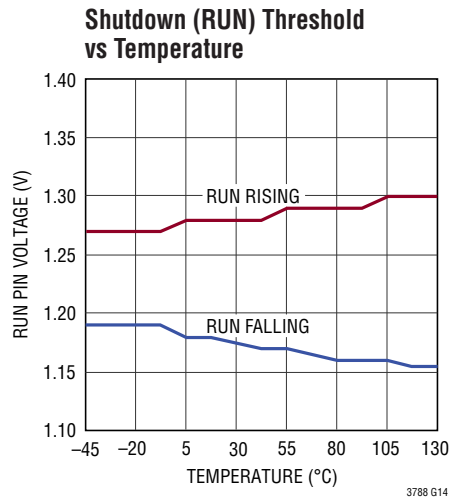
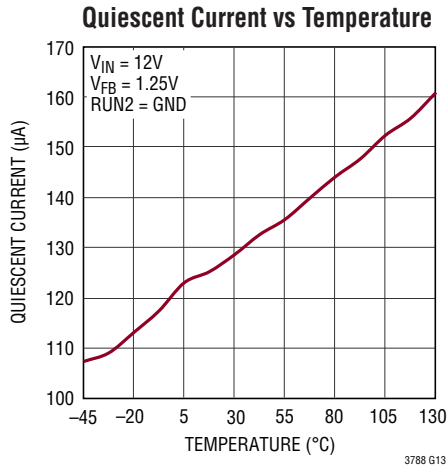

## TYPICAL PERFORMANCE CHARACTERISTICS

**Oscillator Frequency vs Temperature**

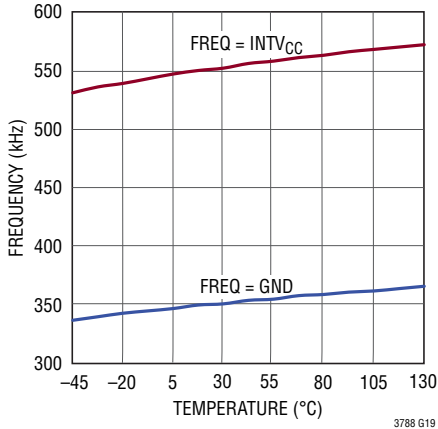

**Oscillator Frequency vs Input Voltage**

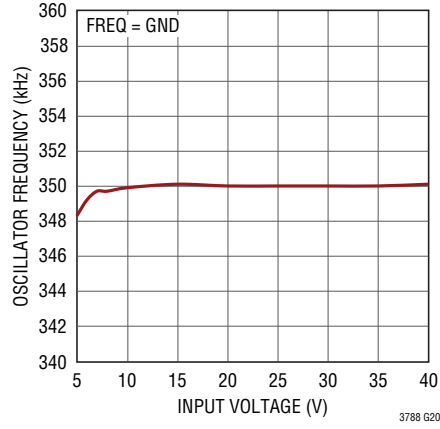

**Maximum Current Sense Threshold vs  $I_{TH}$  Voltage**

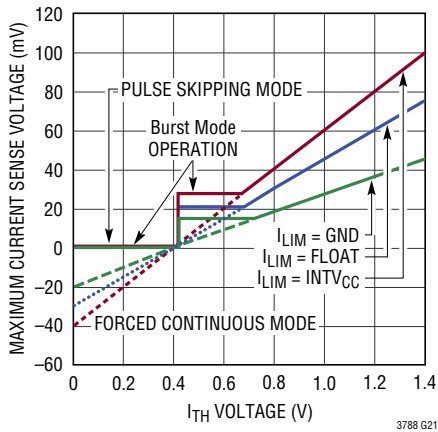

**SENSE Pin Input Current vs Temperature**

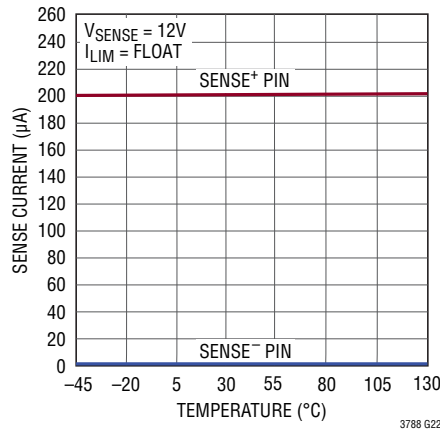

**SENSE Pin Input Current vs  $I_{TH}$  Voltage**

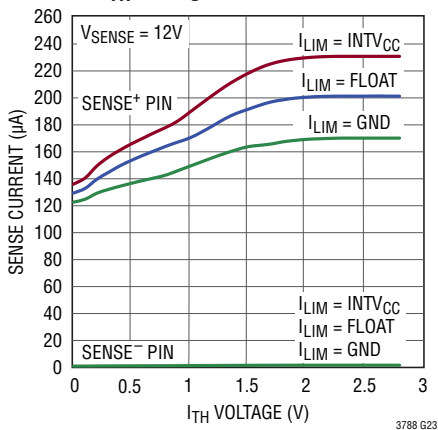

**SENSE Pin Input Current vs  $V_{SENSE}$  Voltage**

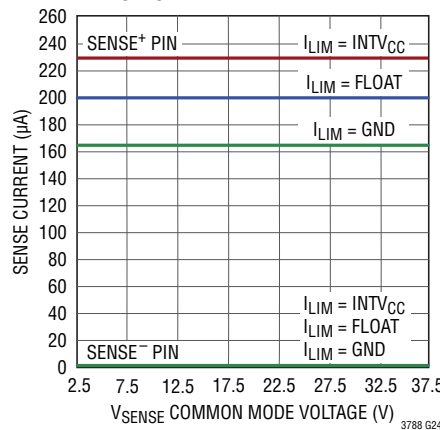

## TYPICAL PERFORMANCE CHARACTERISTICS

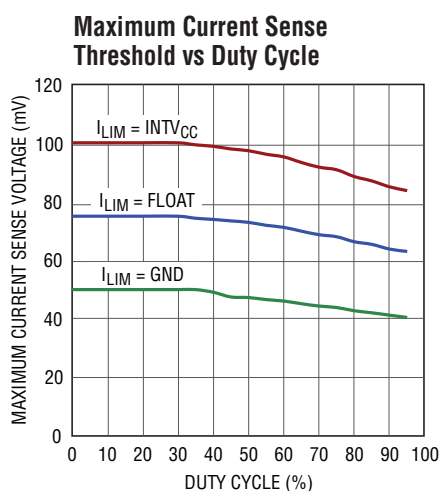

3788 G25

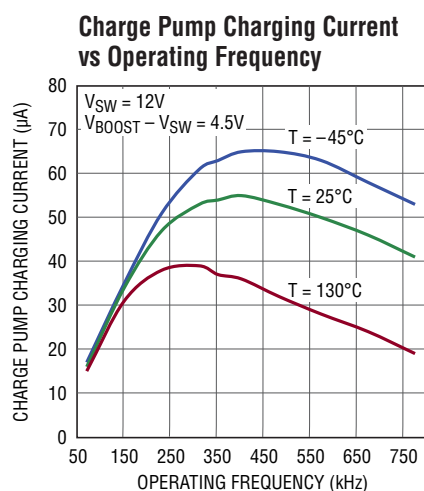

3788 G26

## PIN FUNCTIONS

**SENSE1<sup>-</sup>, SENSE2<sup>-</sup> (Pin 1, Pin 9):** Negative Current Sense Comparator Input. The (–) input to the current comparator is normally connected to the negative terminal of a current sense resistor connected in series with the inductor. The common mode voltage range on these pins is 2.5V to 38V (abs max).

**FREQ (Pin 2):** The frequency control pin for the internal VCO. Connecting the pin to GND forces the VCO to a fixed low frequency of 350kHz. Connecting the pin to INTV<sub>CC</sub> forces the VCO to a fixed high frequency of 535kHz. The frequency can be programmed from 50kHz to 900kHz by connecting a resistor from the FREQ pin to GND. The resistor and an internal 20µA source current create a voltage used by the internal oscillator to set the frequency. Alternatively, this pin can be driven with a DC voltage to vary the frequency of the internal oscillator.

**PHASMD (Pin 3):** This pin can be floated, tied to SGND, or tied to INTV<sub>CC</sub> to program the phase relationship between the rising edges of BG1 and BG2, as well as the phase relationship between BG1 and CLKOUT.

**CLKOUT (Pin 4):** A Digital Output Used for Daisy chaining Multiple LTC3788 ICs in Multiphase Systems. The PHASMD pin voltage controls the relationship between BG1, BG2 and CLKOUT. This pin swings between SGND and INTV<sub>CC</sub>.

**PLLIN/MODE (Pin 5):** External Synchronization Input to Phase Detector and Forced Continuous Mode Input. When an external clock is applied to this pin, it will force the controller into forced continuous mode of operation and the phase-locked loop will force the rising BG1 signal to be synchronized with the rising edge of the external clock. When not synchronizing to an external clock, this input, which acts on both controllers, determines how the LTC3788 operates at light loads. Pulling this pin to ground selects Burst Mode operation. An internal 100k resistor to ground also invokes Burst Mode operation when the pin is floated. Tying this pin to INTV<sub>CC</sub> forces continuous inductor current operation. Tying this pin to a voltage greater than 1.2V and less than INTV<sub>CC</sub> – 1.3V selects pulse-skipping operation. This can be done by adding a 100k resistor between the PLLIN/MODE pin and INTV<sub>CC</sub>.

**SGND (Pin 6):** Signal Ground. All small-signal components and compensation components should connect to this ground, which in turn connects to PGND at a single point.

**RUN1, RUN2 (Pin 7, Pin 8):** Run Control Input. An external resistor divider connects to V<sub>IN</sub> and sets the thresholds for converter operation with a threshold of 1.28V. Once running, a 4.5µA current is sourced from the RUN pin allowing the user to program hysteresis using the resistor values.

3788fc

## PIN FUNCTIONS

**PGOOD2 (Pin 14):** Power Good Indicator for Channel 2. Open-drain logic output that is pulled to ground when the output voltage is more than  $\pm 10\%$  away from the regulated output voltage. To avoid false trips the output voltage must be outside the range for  $25\mu\text{s}$  before this output is activated.

**INTV<sub>CC</sub> (Pin 19):** Output of Internal 5.4V LDO. Power supply for control circuits and gate drives. Decouple this pin to GND with a minimum  $4.7\mu\text{F}$  low ESR tantalum or ceramic capacitor.

**EXTV<sub>CC</sub> (Pin 20):** External Power Input. When this pin is higher than 4.8V an internal switch bypasses the internal regulator and supply power to INTV<sub>CC</sub> directly from EXTV<sub>CC</sub>.

**PGND (Pin 21):** Driver Power Ground. Connects to the sources of bottom (main) N-channel MOSFETs and the (-) terminal(s) of C<sub>IN</sub> and C<sub>OUT</sub>.

**VBIAS (Pin 22):** Main Supply Pin. It is normally tied to the input supply V<sub>IN</sub> or to the output of the boost converter. A bypass capacitor should be tied between this pin and the signal ground pin. The operating voltage range on this pin is 4.5V to 38V (40V abs max).

**BG1, BG2 (Pin 23, Pin 18):** Bottom Gate. Connect to the gate of the main NMOS.

**BOOST1, BOOST2 (Pin 24, Pin 17):** Floating power supply for the synchronous NMOS. Bypass to SW with a capacitor and supply with a Schottky diode connected to INTV<sub>CC</sub>.

**TG1, TG2 (Pin 25, Pin 16):** Top Gate. Connect to the gate of the synchronous NMOS.

**SW1, SW2 (Pin 26, Pin 15):** Switch Node. Connect to the source of the synchronous NMOS, the drain of the main NMOS and the inductor.

**PGOOD1 (Pin 27):** Power Good Indicator for Channel 1. Open-drain logic output that is pulled to ground when the output voltage is more than  $\pm 10\%$  away from the regulated output voltage. To avoid false trips the output voltage must be outside the range for  $25\mu\text{s}$  before this output is activated.

**ILIM (Pin 28):** Current Comparator Sense Voltage Range Input. This pin is used to set the peak current sense voltage in the current comparator. Connect this pin to SGND, open and INTV<sub>CC</sub> to set the peak current sense voltage to 50mV, 75mV, and 100mV, respectively.

**SS1, SS2 (Pin 29, Pin 13):** Output Soft-Start Input. A capacitor to ground at this pin sets the ramp rate of the output voltage during start-up.

**ITH1, ITH2 (Pin 30, Pin 12):** Current Control Threshold and Error Amplifier Compensation Point. The voltage on this pin sets the current trip threshold.

**VFB1, VFB2 (Pin 31, Pin 11):** Error Amplifier Feedback Input. This pin receives the remotely sensed feedback voltage from an external resistive divider connected across the output.

**SENSE1<sup>+</sup>, SENSE2<sup>+</sup> (Pin 32, Pin 10):** Positive Current Sense Comparator Input. The (+) input to the current comparator is normally connected to the positive terminal of a current sense resistor. The current sense resistor is normally placed at the input of the boost controller in series with the inductor. This pin also supplies power to the current comparator.

**GND (Exposed Pad Pin 33):** Ground. The exposed pad must be soldered to the circuit board for rated thermal performance.

# BLOCK DIAGRAM

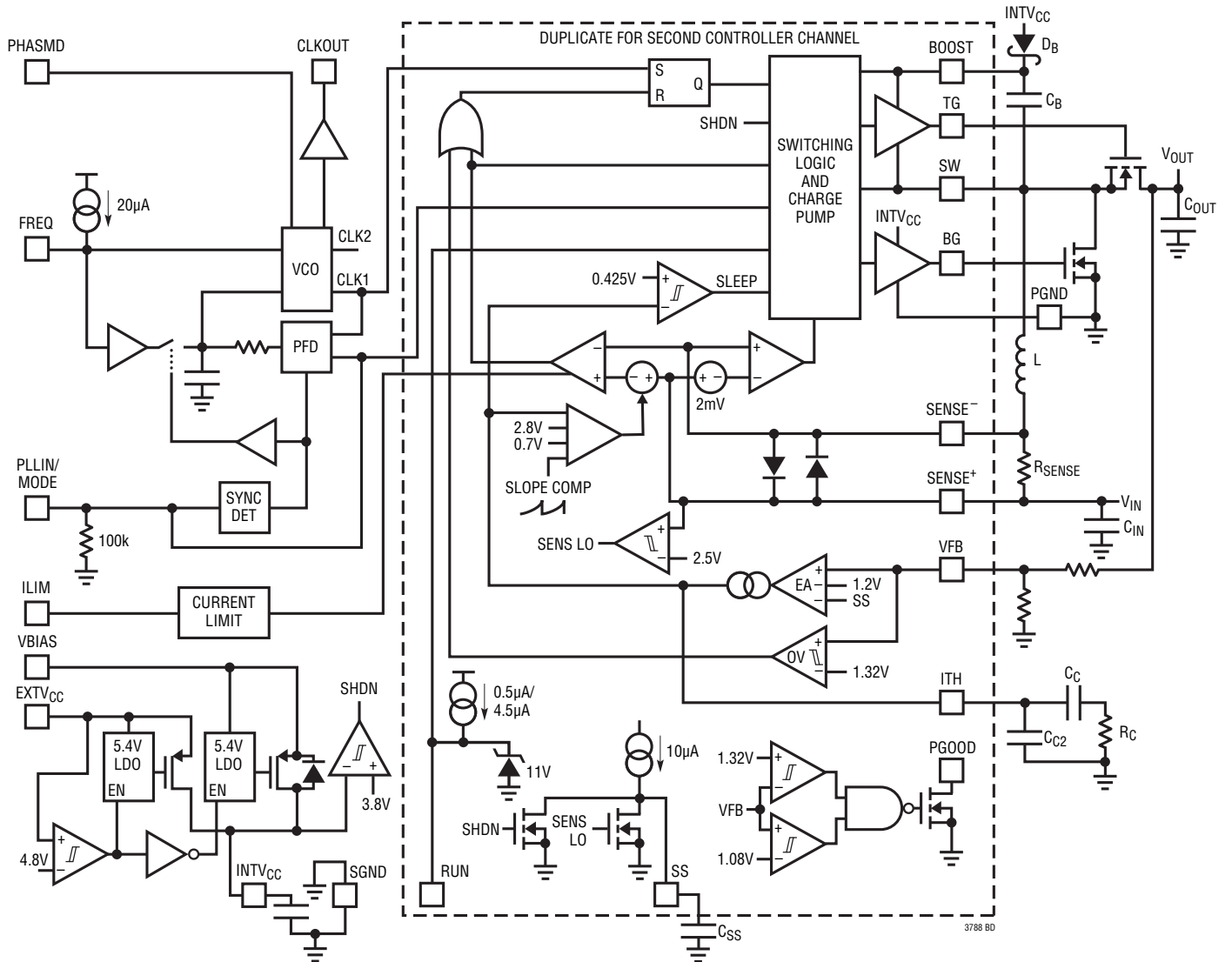

3788 BD

## OPERATION (Refer to Block Diagram)

### Main Control Loop

The LTC3788 uses a constant-frequency, current mode step-up architecture with the two controller channels operating 180 or 240 degrees out-of-phase (depending on the PHASMD pin connection). During normal operation, each external bottom MOSFET is turned on when the clock for that channel sets the RS latch, and is turned off when the main current comparator, ICMP, resets the RS latch. The peak inductor current at which ICMP trips and resets the latch is controlled by the voltage on the ITH pin, which is the output of the error amplifier EA. The error amplifier compares the output voltage feedback signal at the VFB pin, (which is generated with an external resistor divider connected across the output voltage,  $V_{OUT}$ , to ground) to the internal 1.200V reference voltage. When the load current increases, it causes a slight decrease in  $V_{FB}$  relative to the reference, which causes the EA to increase the  $I_{TH}$  voltage until the average inductor current matches the new load current.

After the bottom MOSFET is turned off each cycle, the top MOSFET is turned on until either the inductor current starts to reverse, as indicated by the current comparator IR, or the beginning of the next clock cycle.

### INTV<sub>CC</sub>/EXTV<sub>CC</sub> Power

Power for the top and bottom MOSFET drivers and most other internal circuitry is derived from the INTV<sub>CC</sub> pin. When the EXTV<sub>CC</sub> pin is left open or tied to a voltage less than 4.8V, the VBIAS LDO (low dropout linear regulator) supplies 5.4V from VBIAS to INTV<sub>CC</sub>. If EXTV<sub>CC</sub> is taken above 4.8V, the VBIAS LDO is turned off and an EXTV<sub>CC</sub> LDO is turned on. Once enabled, the EXTV<sub>CC</sub> LDO supplies 5.4V from EXTV<sub>CC</sub> to INTV<sub>CC</sub>. Using the EXTV<sub>CC</sub> pin allows the INTV<sub>CC</sub> power to be derived from a high efficiency external source such as one of the LTC3788 switching regulator outputs.

### Shutdown and Start-Up (RUN1, RUN2 and SS1, SS2 Pins)

The two channels of the LTC3788 can be independently shut down using the RUN1 and RUN2 pins. Pulling either of these pins below 1.28V shuts down the main control loop

for that controller. Pulling both pins below 0.7V disables both controllers and most internal circuits, including the INTV<sub>CC</sub> LDOs. In this state, the LTC3788 draws only 8 $\mu$ A of quiescent current.

The RUN pin may be externally pulled up or driven directly by logic. When driving the RUN pin with a low impedance source, do not exceed the absolute maximum rating of 8V. The RUN pin has an internal 11V voltage clamp that allows the RUN pin to be connected through a resistor to a higher voltage (for example,  $V_{IN}$ ), as long as the maximum current into the RUN pin does not exceed 100 $\mu$ A.

The start-up of each controller's output voltage  $V_{OUT}$  is controlled by the voltage on the SS pin for that channel. When the voltage on the SS pin is less than the 1.2V internal reference, the LTC3788 regulates the  $V_{FB}$  voltage to the SS pin voltage instead of the 1.2V reference. This allows the SS pin to be used to program a soft-start by connecting an external capacitor from the SS pin to SGND. An internal 10 $\mu$ A pull-up current charges this capacitor creating a voltage ramp on the SS pin. As the SS voltage rises linearly from 0V to 1.2V (and beyond up to INTV<sub>CC</sub>), the output voltage  $V_{OUT}$  rises smoothly to its final value.

### Light Load Current Operation—Burst Mode Operation, Pulse-Skipping or Continuous Conduction (PLLIN/MODE Pin)

The LTC3788 can be enabled to enter high efficiency Burst Mode operation, constant-frequency pulse-skipping mode or forced continuous conduction mode at low load currents. To select Burst Mode operation, tie the PLLIN/ MODE pin to a ground (e.g., SGND). To select forced continuous operation, tie the PLLIN/MODE pin to INTV<sub>CC</sub>. To select pulse-skipping mode, tie the PLLIN/MODE pin to a DC voltage greater than 1.2V and less than INTV<sub>CC</sub> – 1.3V.

When a controller is enabled for Burst Mode operation, the minimum peak current in the inductor is set to approximately 30% of the maximum sense voltage even though the voltage on the ITH pin indicates a lower value. If the average inductor current is higher than the load current, the error amplifier EA will decrease the voltage on the ITH pin. When the  $I_{TH}$  voltage drops below 0.425V, the internal sleep signal goes high (enabling sleep mode) and both external MOSFETs are turned off.

## OPERATION

In sleep mode, much of the internal circuitry is turned off, reducing the quiescent current that the LTC3788 draws. If one channel is shut down and the other channel is in sleep mode, the LTC3788 draws only 125 $\mu$ A of quiescent current. If both channels are in sleep mode, the LTC3788 draws only 200 $\mu$ A of quiescent current. In sleep mode, the load current is supplied by the output capacitor. As the output voltage decreases, the EA's output begins to rise. When the output voltage drops enough, the ITH pin is reconnected to the output of the EA, the sleep signal goes low, and the controller resumes normal operation by turning on the bottom external MOSFET on the next cycle of the internal oscillator.

When a controller is enabled for Burst Mode operation, the inductor current is not allowed to reverse. The reverse current comparator (IR) turns off the top external MOSFET just before the inductor current reaches zero, preventing it from reversing and going negative. Thus, the controller operates in discontinuous current operation.

In forced continuous operation or when clocked by an external clock source to use the phase-locked loop (see the Frequency Selection and Phase-Locked Loop section), the inductor current is allowed to reverse at light loads or under large transient conditions. The peak inductor current is determined by the voltage on the ITH pin, just as in normal operation. In this mode, the efficiency at light loads is lower than in Burst Mode operation. However, continuous operation has the advantages of lower output voltage ripple and less interference to audio circuitry, as it maintains constant-frequency operation independent of load current.

When the PLLIN/MODE pin is connected for pulse-skipping mode, the LTC3788 operates in PWM pulse-skipping mode at light loads. In this mode, constant-frequency operation is maintained down to approximately 1% of designed maximum output current. At very light loads, the current comparator  $I_{CMP}$  may remain tripped for several cycles and force the external bottom MOSFET to stay off for the same number of cycles (i.e., skipping pulses). The inductor current is not allowed to reverse (discontinuous operation). This mode, like forced continuous operation, exhibits low output ripple as well as low audio noise and reduced RF interference as compared to Burst Mode

operation. It provides higher low current efficiency than forced continuous mode, but not nearly as high as Burst Mode operation.

### Frequency Selection and Phase-Locked Loop (FREQ and PLLIN/MODE Pins)

The selection of switching frequency is a trade-off between efficiency and component size. Low frequency operation increases efficiency by reducing MOSFET switching losses, but requires larger inductance and/or capacitance to maintain low output ripple voltage.

The switching frequency of the LTC3788's controllers can be selected using the FREQ pin.

If the PLLIN/MODE pin is not being driven by an external clock source, the FREQ pin can be tied to SGND, tied to INTV<sub>CC</sub>, or programmed through an external resistor. Tying FREQ to SGND selects 350kHz while tying FREQ to INTV<sub>CC</sub> selects 535kHz. Placing a resistor between FREQ and SGND allows the frequency to be programmed between 50kHz and 900kHz, as shown in Figure 6.

A phase-locked loop (PLL) is available on the LTC3788 to synchronize the internal oscillator to an external clock source that is connected to the PLLIN/MODE pin. The LTC3788's phase detector adjusts the voltage (through an internal lowpass filter) of the VCO input to align the turn-on of the first controller's external bottom MOSFET to the rising edge of the synchronizing signal. Thus, the turn-on of the second controller's external bottom MOSFET is 180 or 240 degrees out-of-phase to the rising edge of the external clock source.

The VCO input voltage is prebiased to the operating frequency set by the FREQ pin before the external clock is applied. If prebiased near the external clock frequency, the PLL loop only needs to make slight changes to the VCO input in order to synchronize the rising edge of the external clock's to the rising edge of BG1. The ability to prebias the loop filter allows the PLL to lock-in rapidly without deviating far from the desired frequency.

The typical capture range of the LTC3788's PLL is from approximately 55kHz to 1MHz, and is guaranteed to lock to an external clock source whose frequency is between 75kHz and 850kHz.

## OPERATION

The typical input clock thresholds on the PLLIN/MODE pin are 1.6V (rising) and 1.2V (falling).

### PolyPhase Applications (CLKOUT and PHASMD Pins)

The LTC3788 features two pins (CLKOUT and PHASMD) that allow other controller ICs to be daisy-chained with the LTC3788 in PolyPhase® applications. The clock output signal on the CLKOUT pin can be used to synchronize additional power stages in a multiphase power supply solution feeding a single, high current output or multiple separate outputs. The PHASMD pin is used to adjust the phase of the CLKOUT signal as well as the relative phases between the two internal controllers, as summarized in Table 1. The phases are calculated relative to the zero degrees phase being defined as the rising edge of the bottom gate driver output of controller 1 (BG1).

Table 1.

V <sub>PHASMD</sub>	CONTROLLER 2 PHASE (°C)	CLKOUT PHASE (°C)
GND	180	60
Floating	180	90
INTV <sub>CC</sub>	240	120

CLKOUT is disabled when one of the channels is in sleep mode and another channel is either in shutdown or in sleep mode.

### Operation When $V_{IN} > V_{OUT}$

When  $V_{IN}$  rises above the regulated  $V_{OUT}$  voltage, the boost controller can behave differently depending on the mode, inductor current and  $V_{IN}$  voltage. In forced continuous mode, the loop works to keep the top MOSFET on continuously once  $V_{IN}$  rises above  $V_{OUT}$ . The internal charge pump delivers current to the boost capacitor to maintain a sufficiently high TG voltage.

In pulse-skipping mode, if  $V_{IN}$  is between 100% and 110% of the regulated  $V_{OUT}$  voltage, TG turns on if the inductor current rises above a certain threshold and turns off if the inductor current falls below this threshold. This threshold current is set to approximately 6%, 4% or 3% of the maximum  $I_{LIM}$  current when the ILIM pin is grounded, floating or tied to INTV<sub>CC</sub>, respectively. If the controller is programmed to Burst Mode operation under

this same  $V_{IN}$  window, then TG remains off regardless of the inductor current.

If  $V_{IN}$  rises above 110% of the regulated  $V_{OUT}$  voltage in any mode, the controller turns on TG regardless of the inductor current. In Burst Mode operation, however, the internal charge pump turns off if the entire chip is asleep (the other channel is asleep or shut down). With the charge pump off, there would be nothing to prevent the boost capacitor from discharging, resulting in an insufficient TG voltage needed to keep the top MOSFET completely on. To prevent excessive power dissipation across the body diode of the top MOSFET in this situation, the chip can be switched over to forced continuous mode to enable the charge pump, or a Schottky diode can also be placed in parallel to the top MOSFET.

### Power Good

The PGOOD1,2 pin is connected to an open-drain of an internal N-channel MOSFET. The MOSFET turns on and pulls the PGOOD1,2 pin low when the corresponding VFB1,2 pin voltage is not within  $\pm 10\%$  of the 1.2V reference voltage. The PGOOD1,2 pin is also pulled low when the corresponding RUN1,2 pin is low (shut down). When the VFB1,2 pin voltage is within the  $\pm 10\%$  requirement, the MOSFET is turned off and the pin is allowed to be pulled up by an external resistor to a source of up to 6V.

### Operation at Low SENSE Pin Common Voltage

The current comparator in the LTC3788 is powered directly from the SENSE<sup>+</sup> pin. This enables the common mode voltage of SENSE<sup>+</sup> and SENSE<sup>-</sup> pins to operate at as low as 2.5V, which is below the UVLO threshold. The figure on the first page shows a typical application when the controller's VBIAS is powered from  $V_{OUT}$  while  $V_{IN}$  supply can go as low as 2.5V. If the voltage on SENSE<sup>+</sup> drops below 2.5V, the SS pin will be held low. When the SENSE voltage returns to the normal operating range, the SS pin will be released, initiating a new soft-start cycle.

### BOOST Supply Refresh and Internal Charge Pump

Each top MOSFET driver is biased from the floating bootstrap capacitor  $C_B$ , which normally recharges during each cycle through an external diode when the bottom

## OPERATION

MOSFET turns on. There are two considerations to keep the BOOST supply at the required bias level. During start-up, if the bottom MOSFET is not turned on within 100 $\mu$ s after UVLO goes low, the bottom MOSFET will be forced to turn on for ~400ns. This forced refresh generates enough BOOST-SW voltage to allow the top MOSFET ready to be fully enhanced instead of waiting for the initial

few cycles to charge up. There is also an internal charge pump that keeps the required bias on BOOST. The charge pump always operates in both forced continuous mode and pulse-skipping mode. In Burst Mode operation, the charge pump is turned off during sleep and enabled when the chip wakes up. The internal charge pump can normally supply a charging current of 55 $\mu$ A.

## APPLICATIONS INFORMATION

The Typical Application on the first page is a basic LTC3788 application circuit. LTC3788 can be configured to use either inductor DCR (DC resistance) sensing or a discrete sense resistor ( $R_{SENSE}$ ) for current sensing. The choice between the two current sensing schemes is largely a design trade-off between cost, power consumption and accuracy. DCR sensing is becoming popular because it does not require current sensing resistors and is more power-efficient, especially in high current applications. However, current sensing resistors provide the most accurate current limits for the controller. Other external component selection is driven by the load requirement, and begins with the selection of  $R_{SENSE}$  (if  $R_{SENSE}$  is used) and inductor value. Next, the power MOSFETs are selected. Finally, input and output capacitors are selected.

### SENSE<sup>+</sup> and SENSE<sup>-</sup> Pins

The SENSE<sup>+</sup> and SENSE<sup>-</sup> pins are the inputs to the current comparators. The common mode input voltage range of the current comparators is 2.5V to 38V. The current sense resistor is normally placed at the input of the boost controller in series with the inductor.

The SENSE<sup>+</sup> pin also provides power to the current comparator. It draws ~200 $\mu$ A during normal operation. There is a small base current of less than 1 $\mu$ A that flows into the SENSE<sup>-</sup> pin. The high impedance SENSE<sup>-</sup> input to the current comparators allow accurate DCR sensing.

Filter components mutual to the sense lines should be placed close to the LTC3788, and the sense lines should run close together to a Kelvin connection underneath the current sense element (shown in Figure 1). Sensing cur-

rent elsewhere can effectively add parasitic inductance and capacitance to the current sense element, degrading the information at the sense terminals and making the programmed current limit unpredictable. If DCR sensing is used (Figure 2b), sense resistor R1 should be placed close to the switching node, to prevent noise from coupling into sensitive small-signal nodes.

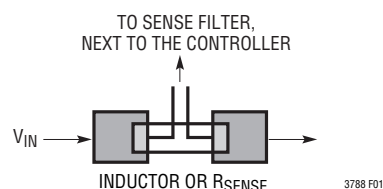

Figure 1. Sense Lines Placement with Inductor or Sense Resistor

### Sense Resistor Current Sensing

A typical sensing circuit using a discrete resistor is shown in Figure 2a.  $R_{SENSE}$  is chosen based on the required output current.

The current comparator has a maximum threshold  $V_{SENSE(MAX)}$ . When the ILIM pin is grounded, floating or tied to  $INTV_{CC}$ , the maximum threshold is set to 50mV, 75mV or 100mV, respectively. The current comparator threshold sets the peak of the inductor current, yielding a maximum average output current,  $I_{MAX}$ , equal to the peak value less half the peak-to-peak ripple current,  $\Delta I_L$ . To calculate the sense resistor value, use the equation:

$$R_{SENSE} = \frac{V_{SENSE(MAX)}}{I_{MAX} + \frac{\Delta I_L}{2}}$$

## APPLICATIONS INFORMATION

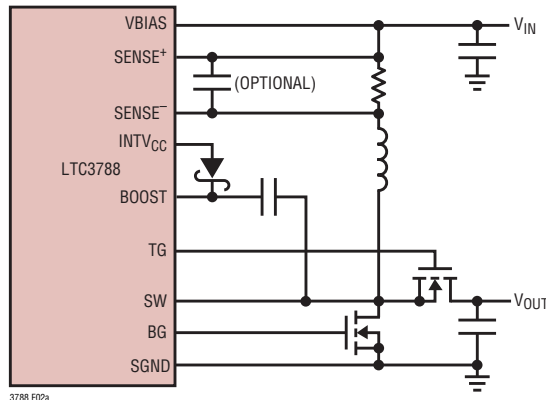

(2a) Using a Resistor to Sense Current

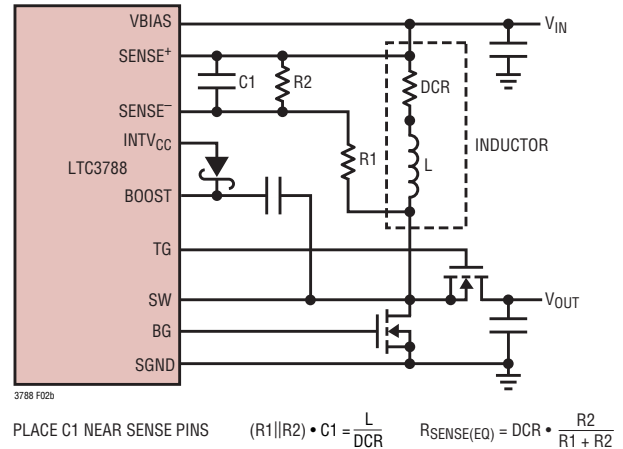

(2b) Using the Inductor DCR to Sense Current

Figure 2. Two Different Methods of Sensing Current

When using the controller in low  $V_{IN}$  and very high voltage output applications, the maximum output current level will be reduced due to the internal compensation required to meet stability criterion for boost regulators operating at greater than 50% duty factor. A curve is provided in the Typical Performance Characteristics section to estimate this reduction in peak output current level depending upon the operating duty factor.

### Inductor DCR Sensing

For applications requiring the highest possible efficiency at high load currents, the LTC3788 is capable of sensing the voltage drop across the inductor DCR, as shown in Figure 2b. The DCR of the inductor can be less than 1m $\Omega$  for high current inductors. In a high current application requiring such an inductor, conduction loss through a sense resistor could reduce the efficiency by a few percent compared to DCR sensing.

If the external  $R1||R2 \cdot C1$  time constant is chosen to be exactly equal to the  $L/DCR$  time constant, the voltage drop across the external capacitor is equal to the drop across the inductor DCR multiplied by  $R2/(R1 + R2)$ .  $R2$  scales the voltage across the sense terminals for applications where the DCR is greater than the target sense resistor value. To properly dimension the external filter components, the DCR of the inductor must be known. It can be measured using a good RLC meter, but the DCR tolerance is not

always the same and varies with temperature. Consult the manufacturer's data sheets for detailed information.

Using the inductor ripple current value from the inductor value calculation section, the target sense resistor value is:

$$R_{SENSE(EQUIV)} = \frac{V_{SENSE(MAX)}}{I_{MAX} + \frac{\Delta I_L}{2}}$$

To ensure that the application will deliver full load current over the full operating temperature range, choose the minimum value for the maximum current sense threshold ( $V_{SENSE(MAX)}$ ).

Next, determine the DCR of the inductor. Where provided, use the manufacturer's maximum value, usually given at 20°C. Increase this value to account for the temperature coefficient of resistance, which is approximately 0.4%/°C. A conservative value for the maximum inductor temperature ( $T_{L(MAX)}$ ) is 100°C.

To scale the maximum inductor DCR to the desired sense resistor value, use the divider ratio:

$$R_D = \frac{R_{SENSE(EQUIV)}}{DCR_{MAX} \text{ at } T_{L(MAX)}}$$

$C1$  is usually selected to be in the range of 0.1 $\mu$ F to 0.47 $\mu$ F. This forces  $R1||R2$  to around 2k, reducing error that might have been caused by the  $SENSE^+$  pin's  $\pm 1\mu$ A current.

## APPLICATIONS INFORMATION

The equivalent resistance  $R1 \parallel R2$  is scaled to the room temperature inductance and maximum DCR:

$$R1 \parallel R2 = \frac{L}{(\text{DCR at } 20^{\circ}\text{C}) \cdot C1}$$

The sense resistor values are:

$$R1 = \frac{R1 \parallel R2}{R_D}; \quad R2 = \frac{R1 \cdot R_D}{1 - R_D}$$

The maximum power loss in R1 is related to duty cycle, and will occur in continuous mode at  $V_{IN} = 1/2 V_{OUT}$ :

$$P_{\text{Loss } R1} = \frac{(V_{OUT} - V_{IN}) \cdot V_{IN}}{R1}$$

Ensure that R1 has a power rating higher than this value. If high efficiency is necessary at light loads, consider this power loss when deciding whether to use DCR sensing or sense resistors. Light load power loss can be modestly higher with a DCR network than with a sense resistor, due to the extra switching losses incurred through R1. However, DCR sensing eliminates a sense resistor, reduces conduction losses and provides higher efficiency at heavy loads. Peak efficiency is about the same with either method.

### Inductor Value Calculation

The operating frequency and inductor selection are inter-related in that higher operating frequencies allow the use of smaller inductor and capacitor values. Why would anyone ever choose to operate at lower frequencies with larger components? The answer is efficiency. A higher frequency generally results in lower efficiency because of MOSFET gate charge and switching losses. In addition to this basic trade-off, the effect of inductor value on ripple current and low current operation must also be considered.

The inductor value has a direct effect on ripple current. The inductor ripple current  $\Delta I_L$  decreases with higher inductance or frequency and increases with higher  $V_{IN}$ :

$$\Delta I_L = \frac{V_{IN}}{f \cdot L} \left( 1 - \frac{V_{IN}}{V_{OUT}} \right)$$

Accepting larger values of  $\Delta I_L$  allows the use of low inductances, but results in higher output voltage ripple and greater core losses. A reasonable starting point for

setting ripple current is  $\Delta I_L = 0.3(I_{MAX})$ . The maximum  $\Delta I_L$  occurs at  $V_{IN} = 1/2 V_{OUT}$ .

The inductor value also has secondary effects. The transition to Burst Mode operation begins when the average inductor current required results in a peak current below 10% of the current limit determined by  $R_{SENSE}$ . Lower inductor values (higher  $\Delta I_L$ ) will cause this to occur at lower load currents, which can cause a dip in efficiency in the upper range of low current operation. In Burst Mode operation, lower inductance values will cause the burst frequency to decrease.

### Inductor Core Selection

Once the value for L is known, the type of inductor must be selected. High efficiency converters generally cannot afford the core loss found in low cost powdered iron cores, forcing the use of more expensive ferrite or molypermalloy cores. Actual core loss is independent of core size for a fixed inductor value, but it is very dependent on inductance selected. As inductance increases, core losses go down. Unfortunately, because increased inductance requires more turns of wire, copper losses will increase.

Ferrite core inductors have very low core loss and are preferred at high switching frequencies, so design goals can concentrate on copper loss and preventing saturation. Ferrite core material saturates “hard,” which means that inductance collapses abruptly when the peak design current is exceeded. This results in an abrupt increase in inductor ripple current and consequent output voltage ripple. Do not allow the core to saturate!

### Power MOSFET Selection

Two external power MOSFETs must be selected for each controller in the LTC3788: one N-channel MOSFET for the bottom (main) switch, and one N-channel MOSFET for the top (synchronous) switch.

The peak-to-peak gate drive levels are set by the  $INTV_{CC}$  voltage. This voltage is typically 5.4V during start-up (see  $EXTV_{CC}$  pin connection). Consequently, logic-level threshold MOSFETs must be used in most applications. The only exception is if low input voltage is expected ( $V_{IN} < 5V$ ); then, sub-logic level threshold MOSFETs ( $V_{GS(TH)} < 3V$ ) should be used. Pay close attention to the  $BV_{DSS}$

## APPLICATIONS INFORMATION

specification for the MOSFETs as well; many of the logic level MOSFETs are limited to 30V or less.

Selection criteria for the power MOSFETs include the on-resistance  $R_{DS(ON)}$ , Miller capacitance  $C_{MILLER}$ , input voltage and maximum output current. Miller capacitance,  $C_{MILLER}$ , can be approximated from the gate charge curve usually provided on the MOSFET manufacturer's data sheet.  $C_{MILLER}$  is equal to the increase in gate charge along the horizontal axis while the curve is approximately flat divided by the specified change in  $V_{DS}$ . This result is then multiplied by the ratio of the application applied  $V_{DS}$  to the gate charge curve specified  $V_{DS}$ . When the IC is operating in continuous mode, the duty cycles for the top and bottom MOSFETs are given by:

$$\text{Main Switch Duty Cycle} = \frac{V_{OUT} - V_{IN}}{V_{OUT}}$$

$$\text{Synchronous Switch Duty Cycle} = \frac{V_{IN}}{V_{OUT}}$$

The MOSFET power dissipations at maximum output current are given by:

$$P_{MAIN} = \frac{(V_{OUT} - V_{IN})V_{OUT}}{V_{IN}^2} \cdot I_{OUT(MAX)}^2 \cdot (1 + \delta) \\ \cdot R_{DS(ON)} + k \cdot V_{OUT}^3 \cdot \frac{I_{OUT(MAX)}}{V_{IN}} \cdot R_{DR} \\ \cdot C_{MILLER} \cdot f$$

$$P_{SYNC} = \frac{V_{IN}}{V_{OUT}} \cdot I_{OUT(MAX)}^2 \cdot (1 + \delta) \cdot R_{DS(ON)}$$

where  $\delta$  is the temperature dependency of  $R_{DS(ON)}$  and  $R_{DR}$  (approximately  $1\Omega$ ) is the effective driver resistance at the MOSFET's Miller threshold voltage. The constant  $k$ , which accounts for the loss caused by reverse recovery current, is inversely proportional to the gate drive current and has an empirical value of 1.7.

Both MOSFETs have  $I^2R$  losses while the bottom N-channel equation includes an additional term for transition losses, which are highest at low input voltages. For high  $V_{IN}$  the high current efficiency generally improves with larger MOSFETs, while for low  $V_{IN}$  the transition losses rapidly

increase to the point that the use of a higher  $R_{DS(ON)}$  device with lower  $C_{MILLER}$  actually provides higher efficiency. The synchronous MOSFET losses are greatest at high input voltage when the bottom switch duty factor is low or during overvoltage when the synchronous switch is on close to 100% of the period.

The term  $(1 + \delta)$  is generally given for a MOSFET in the form of a normalized  $R_{DS(ON)}$  vs Temperature curve, but  $\delta = 0.005/^\circ\text{C}$  can be used as an approximation for low voltage MOSFETs.

### $C_{IN}$ and $C_{OUT}$ Selection

The input ripple current in a boost converter is relatively low (compared with the output ripple current), because this current is continuous. The input capacitor  $C_{IN}$  voltage rating should comfortably exceed the maximum input voltage. Although ceramic capacitors can be relatively tolerant of overvoltage conditions, aluminum electrolytic capacitors are not. Be sure to characterize the input voltage for any possible overvoltage transients that could apply excess stress to the input capacitors.

The value of the  $C_{IN}$  is a function of the source impedance, and in general, the higher the source impedance, the higher the required input capacitance. The required amount of input capacitance is also greatly affected by the duty cycle. High output current applications that also experience high duty cycles can place great demands on the input supply, both in terms of DC current and ripple current.

In a boost converter, the output has a discontinuous current, so  $C_{OUT}$  must be capable of reducing the output voltage ripple. The effects of ESR (equivalent series resistance) and the bulk capacitance must be considered when choosing the right capacitor for a given output ripple voltage. The steady ripple voltage due to charging and discharging the bulk capacitance is given by:

$$V_{RIPPLE} = \frac{I_{OUT(MAX)} \cdot (V_{OUT} - V_{IN(MIN)})}{C_{OUT} \cdot V_{OUT} \cdot f}$$

where  $C_{OUT}$  is the output filter capacitor.

The steady ripple due to the voltage drop across the ESR is given by:

$$\Delta V_{ESR} = I_{L(MAX)} \cdot ESR$$

## APPLICATIONS INFORMATION

The LTC3788 can also be configured as a 2-phase single output converter where the outputs of the two channels are connected together and both channels have the same duty cycle. With 2-phase operation, the two channels of the dual switching regulator are operated 180 degrees out-of-phase. This effectively interleaves the output capacitor current pulses, greatly reducing the output capacitor ripple current. As a result, the ESR requirement of the capacitor can be relaxed. Because the ripple current in the output capacitor is a square wave, the ripple current requirements for the output capacitor depend on the duty cycle, the number of phases and the maximum output current. Figure 3 illustrates the normalized output capacitor ripple current as a function of duty cycle in a 2-phase configuration. To choose a ripple current rating for the output capacitor, first establish the duty cycle range based on the output voltage and range of input voltage. Referring to Figure 3, choose the worst-case high normalized ripple current as a percentage of the maximum load current.

Multiple capacitors placed in parallel may be needed to meet the ESR and RMS current handling requirements. Dry tantalum, special polymer, aluminum electrolytic and ceramic capacitors are all available in surface mount packages. Ceramic capacitors have excellent low ESR characteristics but can have a high voltage coefficient. Capacitors are now available with low ESR and high ripple current ratings (i.e., OS-CON and POSCAP).

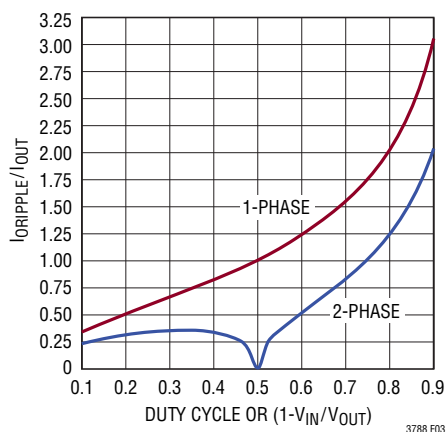

Figure 3. Normalized Output Capacitor Ripple Current (RMS) for a Boost Converter

### Setting Output Voltage

The LTC3788 output voltages are each set by an external feedback resistor divider carefully placed across the output, as shown in Figure 4. The regulated output voltage is determined by:

$$V_{OUT} = 1.2V \left( 1 + \frac{R_B}{R_A} \right)$$

Great care should be taken to route the  $V_{FB}$  line away from noise sources, such as the inductor or the SW line.

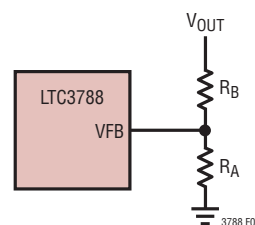

Figure 4. Setting Output Voltage

### Soft-Start (SS Pins)

The start-up of each  $V_{OUT}$  is controlled by the voltage on the respective SS pins. When the voltage on the SS pin is less than the internal 1.2V reference, the LTC3788 regulates the VFB pin voltage to the voltage on the SS pin instead of 1.2V.

Soft-start is enabled by simply connecting a capacitor from the SS pin to ground, as shown in Figure 5. An internal 10 $\mu$ A current source charges the capacitor, providing a linear ramping voltage at the SS pin. The LTC3788 will regulate the VFB pin (and hence,  $V_{OUT}$ ) according to the voltage on the SS pin, allowing  $V_{OUT}$  to rise smoothly from  $V_{IN}$  to its final regulated value. The total soft-start time will be approximately:

$$t_{SS} = C_{SS} \cdot \frac{1.2V}{10\mu A}$$

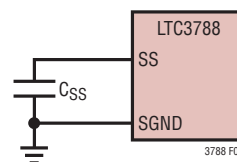

Figure 5. Using the SS Pin to Program Soft-Start

## APPLICATIONS INFORMATION

### INTV<sub>CC</sub> Regulators

The LTC3788 features two separate internal P-channel low dropout linear regulators (LDO) that supply power at the INTV<sub>CC</sub> pin from either the VBIAS supply pin or the EXTV<sub>CC</sub> pin depending on the connection of the EXTV<sub>CC</sub> pin. INTV<sub>CC</sub> powers the gate drivers and much of the LTC3788's internal circuitry. The VBIAS LDO and the EXTV<sub>CC</sub> LDO regulate INTV<sub>CC</sub> to 5.4V. Each of these can supply a peak current of 50mA and must be bypassed to ground with a minimum of 4.7μF ceramic capacitor. Good bypassing is needed to supply the high transient currents required by the MOSFET gate drivers and to prevent interaction between the channels.

High input voltage applications in which large MOSFETs are being driven at high frequencies may cause the maximum junction temperature rating for the LTC3788 to be exceeded. The INTV<sub>CC</sub> current, which is dominated by the gate charge current, may be supplied by either the VBIAS LDO or the EXTV<sub>CC</sub> LDO. When the voltage on the EXTV<sub>CC</sub> pin is less than 4.8V, the VBIAS LDO is enabled. In this case, power dissipation for the IC is highest and is equal to  $V_{IN} \cdot I_{INTVCC}$ . The gate charge current is dependent on operating frequency, as discussed in the Efficiency Considerations section. The junction temperature can be estimated by using the equations given in Note 3 of the Electrical Characteristics. For example, the LTC3788 INTV<sub>CC</sub> current is limited to less than 40mA from a 40V supply when not using the EXTV<sub>CC</sub> supply:

$$T_J = 70^\circ\text{C} + (40\text{mA})(40\text{V})(34^\circ\text{C}/\text{W}) = 125^\circ\text{C}$$

To prevent the maximum junction temperature from being exceeded, the input supply current must be checked while operating in continuous conduction mode (PLLIN/MODE = INTV<sub>CC</sub>) at maximum  $V_{IN}$ .

When the voltage applied to EXTV<sub>CC</sub> rises above 4.8V, the  $V_{IN}$  LDO is turned off and the EXTV<sub>CC</sub> LDO is enabled. The EXTV<sub>CC</sub> LDO remains on as long as the voltage applied to EXTV<sub>CC</sub> remains above 4.55V. The EXTV<sub>CC</sub> LDO attempts to regulate the INTV<sub>CC</sub> voltage to 5.4V, so while EXTV<sub>CC</sub> is less than 5.4V, the LDO is in dropout and the INTV<sub>CC</sub> voltage is approximately equal to EXTV<sub>CC</sub>. When EXTV<sub>CC</sub> is greater than 5.4V, up to an absolute maximum of 6V, INTV<sub>CC</sub> is regulated to 5.4V.

Significant thermal gains can be realized by powering INTV<sub>CC</sub> from an external supply. Tying the EXTV<sub>CC</sub> pin to a 5V supply reduces the junction temperature in the previous example from 125°C to 77°C:

$$T_J = 70^\circ\text{C} + (40\text{mA})(5\text{V})(34^\circ\text{C}/\text{W}) = 77^\circ\text{C}$$

If more current is required through the EXTV<sub>CC</sub> LDO than is specified, an external Schottky diode can be added between the EXTV<sub>CC</sub> and INTV<sub>CC</sub> pins. Make sure that in all cases  $\text{EXTV}_{CC} \leq \text{VBIAS}$ .

The following list summarizes possible connections for EXTV<sub>CC</sub>:

*EXTV<sub>CC</sub> Left Open (or Grounded).* This will cause INTV<sub>CC</sub> to be powered from the internal 5.4V regulator resulting in an efficiency penalty at high input voltages.

*EXTV<sub>CC</sub> Connected to an External Supply.* If an external supply is available in the 5.4V to 6V range, it may be used to power EXTV<sub>CC</sub> providing it is compatible with the MOSFET gate drive requirements. Ensure that  $\text{EXTV}_{CC} < \text{VBIAS}$ .

### Topside MOSFET Driver Supply (C<sub>B</sub>, D<sub>B</sub>)

External bootstrap capacitors  $C_B$  connected to the BOOST pins supply the gate drive voltages for the topside MOSFETs. Capacitor  $C_B$  in the Block Diagram is charged through external diode  $D_B$  from INTV<sub>CC</sub> when the SW pin is low. When one of the topside MOSFETs is to be turned on, the driver places the  $C_B$  voltage across the gate-source of the desired MOSFET. This enhances the MOSFET and turns on the topside switch. The switch node voltage, SW, rises to  $V_{IN}$  and the BOOST pin follows. With the topside MOSFET on, the boost voltage is above the input supply:  $V_{BOOST} = V_{IN} + V_{INTVCC}$ . The value of the boost capacitor  $C_B$  needs to be 100 times that of the total input capacitance of the topside MOSFET(s). The reverse breakdown of the external Schottky diode must be greater than  $V_{IN(\text{MAX})}$ .

The external diode  $D_B$  can be a Schottky diode or silicon diode, but in either case it should have low leakage and fast recovery. Pay close attention to the reverse leakage at high temperatures where it generally increases substantially.

## APPLICATIONS INFORMATION

Each of the topside MOSFET drivers includes an internal charge pump that delivers current to the bootstrap capacitor from the BOOST pin. This charge current maintains the bias voltage required to keep the top MOSFET on continuously during dropout/overvoltage conditions. The Schottky/silicon diodes selected for the topside drivers should have a reverse leakage less than the available output current the charge pump can supply. Curves displaying the available charge pump current under different operating conditions can be found in the Typical Performance Characteristics section.

A leaky diode  $D_B$  in the boost converter can not only prevent the top MOSFET from fully turning on but it can also completely discharge the bootstrap capacitor  $C_B$  and create a current path from the input voltage to the BOOST pin to  $INTV_{CC}$ . This can cause  $INTV_{CC}$  to rise if the diode leakage exceeds the current consumption on  $INTV_{CC}$ . This is particularly a concern in Burst Mode operation where the load on  $INTV_{CC}$  can be very small. The external Schottky or silicon diode should be carefully chosen such that  $INTV_{CC}$  never gets charged up much higher than its normal regulation voltage.

### Fault Conditions: Overtemperature Protection

At higher temperatures, or in cases where the internal power dissipation causes excessive self heating on-chip (such as an  $INTV_{CC}$  short to ground), the overtemperature shutdown circuitry will shut down the LTC3788. When the junction temperature exceeds approximately 170°C, the overtemperature circuitry disables the  $INTV_{CC}$  LDO, causing the  $INTV_{CC}$  supply to collapse and effectively shut down the entire LTC3788 chip. Once the junction temperature drops back to approximately 155°C, the  $INTV_{CC}$  LDO turns back on. Long term overstress ( $T_J > 125^\circ\text{C}$ ) should be avoided as it can degrade the performance or shorten the life of the part.

### Phase-Locked Loop and Frequency Synchronization

The LTC3788 has an internal phase-locked loop (PLL) comprised of a phase frequency detector, a low pass filter and a voltage-controlled oscillator (VCO). This allows the turn-on of the top MOSFET of controller 1 to be locked to the rising edge of an external clock signal applied to the PLLIN/MODE pin. The turn-on of controller 2's top MOSFET is thus 180 degrees out-of-phase with the external clock. The phase detector is an edge-sensitive digital type that provides zero degrees phase shift between the external and internal oscillators. This type of phase detector does not exhibit false lock to harmonics of the external clock.

If the external clock frequency is greater than the internal oscillator's frequency,  $f_{OSC}$ , then current is sourced continuously from the phase detector output, pulling up the VCO input. When the external clock frequency is less than  $f_{OSC}$ , current is sunk continuously, pulling down the VCO input. If the external and internal frequencies are the same but exhibit a phase difference, the current sources turn on for an amount of time corresponding to the phase difference. The voltage at the VCO input is adjusted until the phase and frequency of the internal and external oscillators are identical. At the stable operating point, the phase detector output is high impedance and the internal filter capacitor,  $C_{LP}$ , holds the voltage at the VCO input.

Typically, the external clock (on PLLIN/MODE pin) input high threshold is 1.6V, while the input low threshold is 1.2V.

Note that the LTC3788 can only be synchronized to an external clock whose frequency is within range of the LTC3788's internal VCO, which is nominally 55kHz to 1MHz. This is guaranteed to be between 75kHz and 850kHz.

Rapid phase locking can be achieved by using the FREQ pin to set a free-running frequency near the desired synchronization frequency. The VCO's input voltage is prebiased at a frequency corresponding to the frequency set by the FREQ pin. Once prebiased, the PLL only needs to adjust the frequency slightly to achieve phase lock and synchronization. Although it is not required that the free-running frequency be near external clock frequency, doing so will prevent the operating frequency from passing through a large range of frequencies as the PLL locks.

## APPLICATIONS INFORMATION

Table 2 summarizes the different states in which the FREQ pin can be used.

**Table 2.**

FREQ PIN	PLLIN/MODE PIN	FREQUENCY
0V	DC Voltage	350kHz
INTV <sub>CC</sub>	DC Voltage	535kHz
Resistor	DC Voltage	50kHz to 900kHz
Any of the Above	External Clock	Phase Locked to External Clock

### Minimum On-Time Considerations

Minimum on-time,  $t_{ON(MIN)}$ , is the smallest time duration that the LTC3788 is capable of turning on the bottom MOSFET. It is determined by internal timing delays and the gate charge required to turn on the top MOSFET. Low duty cycle applications may approach this minimum on-time limit.

In forced continuous mode, if the duty cycle falls below what can be accommodated by the minimum on-time, the controller will begin to skip cycles but the output will continue to be regulated. More cycles will be skipped when  $V_{IN}$  increases. Once  $V_{IN}$  rises above  $V_{OUT}$ , the loop works to keep the top MOSFET on continuously. The minimum on-time for the LTC3788 is approximately 110ns.

### Efficiency Considerations

The percent efficiency of a switching regulator is equal to the output power divided by the input power times 100%. It is often useful to analyze individual losses to determine what is limiting the efficiency and which change would produce the greatest improvement. Percent efficiency can be expressed as:

$$\% \text{Efficiency} = 100\% - (L1 + L2 + L3 + \dots)$$

where L1, L2, etc., are the individual losses as a percentage of input power.

Although all dissipative elements in the circuit produce losses, four main sources usually account for most of the losses in LTC3788 circuits: 1) IC  $V_{IN}$  current, 2) INTV<sub>CC</sub> regulator current, 3)  $I^2R$  losses, 4) Bottom MOSFET transition losses.

1. The  $V_{IN}$  current is the DC supply current given in the Electrical Characteristics table, which excludes MOSFET driver and control currents.  $V_{IN}$  current typically results in a small (<0.1%) loss.
2. INTV<sub>CC</sub> current is the sum of the MOSFET driver and control currents. The MOSFET driver current results from switching the gate capacitance of the power MOSFETs. Each time a MOSFET gate is switched from low to high to low again, a packet of charge,  $dQ$ , moves from INTV<sub>CC</sub> to ground. The resulting  $dQ/dt$  is a current out of INTV<sub>CC</sub> that is typically much larger than the control circuit current. In continuous mode,  $I_{GATECHG} = f(Q_T + Q_B)$ , where  $Q_T$  and  $Q_B$  are the gate charges of the topside and bottom side MOSFETs.
3. DC  $I^2R$  losses. These arise from the resistances of the MOSFETs, sensing resistor, inductor and PC board traces and cause the efficiency to drop at high output currents.
4. Transition losses apply only to the bottom MOSFET(s), and become significant only when operating at low input voltages. Transition losses can be estimated from:

$$\text{Transition Loss} = (1.7) \frac{V_{OUT}^3}{V_{IN}} I_{O(MAX)} \cdot C_{RSS} f$$

Other hidden losses, such as copper trace and internal battery resistances, can account for an additional 5% to 10% efficiency degradation in portable systems. It is very important to include these system-level losses during the design phase.

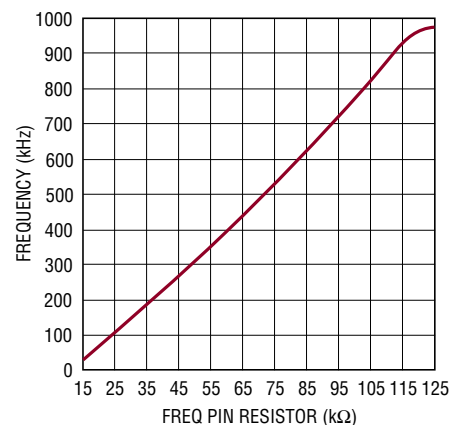

**Figure 6. Relationship Between Oscillator Frequency and Resistor Value at the FREQ Pin**

## APPLICATIONS INFORMATION

### Checking Transient Response

The regulator loop response can be checked by looking at the load current transient response. Switching regulators take several cycles to respond to a step in DC (resistive) load current. When a load step occurs,  $V_{OUT}$  shifts by an amount equal to  $\Delta I_{LOAD}$  (ESR), where ESR is the effective series resistance of  $C_{OUT}$ .  $\Delta I_{LOAD}$  also begins to charge or discharge  $C_{OUT}$  generating the feedback error signal that forces the regulator to adapt to the current change and return  $V_{OUT}$  to its steady-state value. During this recovery time  $V_{OUT}$  can be monitored for excessive overshoot or ringing, which would indicate a stability problem. OPTI-LOOP compensation allows the transient response to be optimized over a wide range of output capacitance and ESR values. *The availability of the ITH pin not only allows optimization of control loop behavior, but it also provides a DC coupled and AC filtered closed loop response test point. The DC step, rise time and settling at this test point truly reflects the closed loop response.* Assuming a predominantly second order system, phase margin and/or damping factor can be estimated using the percentage of overshoot seen at this pin. The bandwidth can also be estimated by examining the rise time at the pin. The  $I_{TH}$  external components shown in the Figure 9 circuit will provide an adequate starting point for most applications.

The  $I_{TH}$  series RC-CC filter sets the dominant pole-zero loop compensation. The values can be modified slightly (from 0.5 to 2 times their suggested values) to optimize transient response once the final PC layout is complete and the particular output capacitor type and value have been determined. The output capacitors must be selected because the various types and values determine the loop gain and phase. An output current pulse of 20% to 80% of full-load current having a rise time of 1 $\mu$ s to 10 $\mu$ s will produce output voltage and ITH pin waveforms that will give a sense of the overall loop stability without breaking the feedback loop.

Placing a power MOSFET and load resistor directly across the output capacitor and driving the gate with an appropriate signal generator is a practical way to produce a realistic load step condition. The initial output voltage step resulting from the step change in output current may not be within the bandwidth of the feedback loop, so this

signal cannot be used to determine phase margin. This is why it is better to look at the ITH pin signal which is in the feedback loop and is the filtered and compensated control loop response.

The gain of the loop will be increased by increasing  $R_C$  and the bandwidth of the loop will be increased by decreasing  $C_C$ . If  $R_C$  is increased by the same factor that  $C_C$  is decreased, the zero frequency will be kept the same, thereby keeping the phase shift the same in the most critical frequency range of the feedback loop. The output voltage settling behavior is related to the stability of the closed-loop system and will demonstrate the actual overall supply performance.

A second, more severe transient is caused by switching in loads with large (>1 $\mu$ F) supply bypass capacitors. The discharged bypass capacitors are effectively put in parallel with  $C_{OUT}$ , causing a rapid drop in  $V_{OUT}$ . No regulator can alter its delivery of current quickly enough to prevent this sudden step change in output voltage if the load switch resistance is low and it is driven quickly. If the ratio of  $C_{LOAD}$  to  $C_{OUT}$  is greater than 1:50, the switch rise time should be controlled so that the load rise time is limited to approximately  $25 \cdot C_{LOAD}$ . Thus, a 10 $\mu$ F capacitor would require a 250 $\mu$ s rise time, limiting the charging current to about 200mA.

### Design Example

As a design example for one channel, assume  $V_{IN}$  = 12V(nominal),  $V_{IN}$  = 22V (max),  $V_{OUT}$  = 24V,  $I_{OUT(MAX)}$  = 4A,  $V_{SENSE(MAX)}$  = 75mV, and  $f$  = 350kHz.

The inductance value is chosen first based on a 30% ripple current assumption. The highest value of ripple current occurs at the maximum input voltage. Tie the PLLPF pin to GND, generating 350kHz operation. The minimum inductance for 30% ripple current is:

$$\Delta I_L = \frac{V_{IN}}{f \cdot L} \left( 1 - \frac{V_{IN}}{V_{OUT}} \right)$$

A 6.8 $\mu$ H inductor will produce a 31% ripple current. The peak inductor current will be the maximum DC value plus one half the ripple current, or 9.25A.

## APPLICATIONS INFORMATION

The  $R_{\text{SENSE}}$  resistor value can be calculated by using the maximum current sense voltage specification with some accommodation for tolerances:

$$R_{\text{SENSE}} \leq \frac{75\text{mV}}{9.25\text{A}} = 0.008\Omega$$

Choosing 1% resistors:  $R_A = 5\text{k}$  and  $R_B = 95.3\text{k}$  yields an output voltage of 24.072V.

The power dissipation on the top side MOSFET can be easily estimated. Choosing a Vishay Si7848BDP MOSFET results in:  $R_{\text{DS(ON)}} = 0.012\Omega$ ,  $C_{\text{MILLER}} = 150\text{pF}$ . At maximum input voltage with  $T(\text{estimated}) = 50^\circ\text{C}$ :

$$P_{\text{MAIN}} = \frac{(24\text{V} - 12\text{V}) 24\text{V}}{(12\text{V})^2} \cdot (4\text{A})^2 \\ \cdot [1 + (0.005)(50^\circ\text{C} - 25^\circ\text{C})] \cdot 0.008\Omega \\ + (1.7)(24\text{V})^3 \frac{4\text{A}}{12\text{V}} (150\text{pF})(350\text{kHz}) = 0.7\text{W}$$

$C_{\text{OUT}}$  is chosen to filter the square current in the output. The maximum output current peak is:

$$I_{\text{OUT(PEAK)}} = 4 \cdot \left(1 + \frac{31\%}{2}\right) = 4.62\text{A}$$

A low ESR (5m $\Omega$ ) capacitor is suggested. This capacitor will limit output voltage ripple to 23.1mV (assuming ESR dominate ripple).

### PC Board Layout Checklist

When laying out the printed circuit board, the following checklist should be used to ensure proper operation of the IC. These items are also illustrated graphically in the layout diagram of Figure 7. Figure 8 illustrates the current waveforms present in the various branches of the 2-phase synchronous regulators operating in the continuous mode. Check the following in your layout:

- Put the bottom N-channel MOSFETs MBOT1 and MBOT2 and the top N-channel MOSFETs MTOP1 and MTOP2 in one compact area with  $C_{\text{OUT}}$ .
- Are the signal and power grounds kept separate? The combined IC signal ground pin and the ground return of  $C_{\text{INTVCC}}$  must return to the combined  $C_{\text{OUT}}(-)$  terminals. The path formed by the bottom N-channel MOSFET and the  $C_{\text{IN}}$  capacitor should have short leads and PC trace lengths. The output capacitor (-) terminals should be connected as close as possible to the (-) terminals of the input capacitor by placing the capacitors next to each other.
- Do the LTC3788 VFB pins' resistive dividers connect to the (+) terminals of  $C_{\text{OUT}}$ ? The resistive divider must be connected between the (+) terminal of  $C_{\text{OUT}}$  and signal ground and placed close to the VFB pin. The feedback resistor connections should not be along the high current input feeds from the input capacitor(s).
- Are the  $\text{SENSE}^-$  and  $\text{SENSE}^+$  leads routed together with minimum PC trace spacing? The filter capacitor between  $\text{SENSE}^+$  and  $\text{SENSE}^-$  should be as close as possible to the IC. Ensure accurate current sensing with Kelvin connections at the sense resistor.
- Is the  $\text{INTV}_{\text{CC}}$  decoupling capacitor connected close to the IC, between the  $\text{INTV}_{\text{CC}}$  and the power ground pins? This capacitor carries the MOSFET drivers' current peaks. An additional 1 $\mu\text{F}$  ceramic capacitor placed immediately next to the  $\text{INTV}_{\text{CC}}$  and PGND pins can help improve noise performance substantially.
- Keep the switching nodes (SW1, SW2), top gate nodes (TG1, TG2) and boost nodes (BOOST1, BOOST2) away from sensitive small-signal nodes, especially from the opposites channel's voltage and current sensing feedback pins. All of these nodes have very large and fast moving signals and, therefore, should be kept on the output side of the LTC3788 and occupy a minimal PC trace area.
- Use a modified "star ground" technique: a low impedance, large copper area central grounding point on the same side of the PC board as the input and output capacitors with tie-ins for the bottom of the  $\text{INTV}_{\text{CC}}$  decoupling capacitor, the bottom of the voltage feedback resistive divider and the SGND pin of the IC.

## APPLICATIONS INFORMATION

### PC Board Layout Debugging

Start with one controller on at a time. It is helpful to use a DC-50MHz current probe to monitor the current in the inductor while testing the circuit. Monitor the output switching node (SW pin) to synchronize the oscilloscope to the internal oscillator and probe the actual output voltage. Check for proper performance over the operating voltage and current range expected in the application. The frequency of operation should be maintained over the input voltage range down to dropout and until the output load drops below the low current operation threshold—typically 10% of the maximum designed current level in Burst Mode operation.

The duty cycle percentage should be maintained from cycle to cycle in a well designed, low noise PCB implementation. Variation in the duty cycle at a subharmonic rate can suggest noise pickup at the current or voltage sensing inputs or inadequate loop compensation. Overcompensation of the loop can be used to tame a poor PC layout if regulator bandwidth optimization is not required. Only after each controller is checked for its individual performance should both controllers be turned on at the same time. A particularly difficult region of operation is when one controller channel is nearing its current comparator trip point while the other channel is turning on its bottom MOSFET. This occurs around the 50% duty cycle on either channel due to the phasing of the internal clocks and may cause minor duty cycle jitter.

Reduce  $V_{IN}$  from its nominal level to verify operation with high duty cycle. Check the operation of the undervoltage lockout circuit by further lowering  $V_{IN}$  while monitoring the outputs to verify operation.

Investigate whether any problems exist only at higher output currents or only at higher input voltages. If problems coincide with high input voltages and low output currents, look for capacitive coupling between the BOOST, SW, TG, and possibly BG connections and the sensitive voltage and current pins. The capacitor placed across the current sensing pins needs to be placed immediately adjacent to the pins of the IC. This capacitor helps to minimize the effects of differential noise injection due to high frequency capacitive coupling.

An embarrassing problem, which can be missed in an otherwise properly working switching regulator results when the current sensing leads are hooked up backwards. The output voltage under this improper hook-up will still be maintained, but the advantages of current mode control will not be realized. Compensation of the voltage loop will be much more sensitive to component selection. This behavior can be investigated by temporarily shorting out the current sensing resistor—don't worry, the regulator will still maintain control of the output voltage.

APPLICATIONS INFORMATION

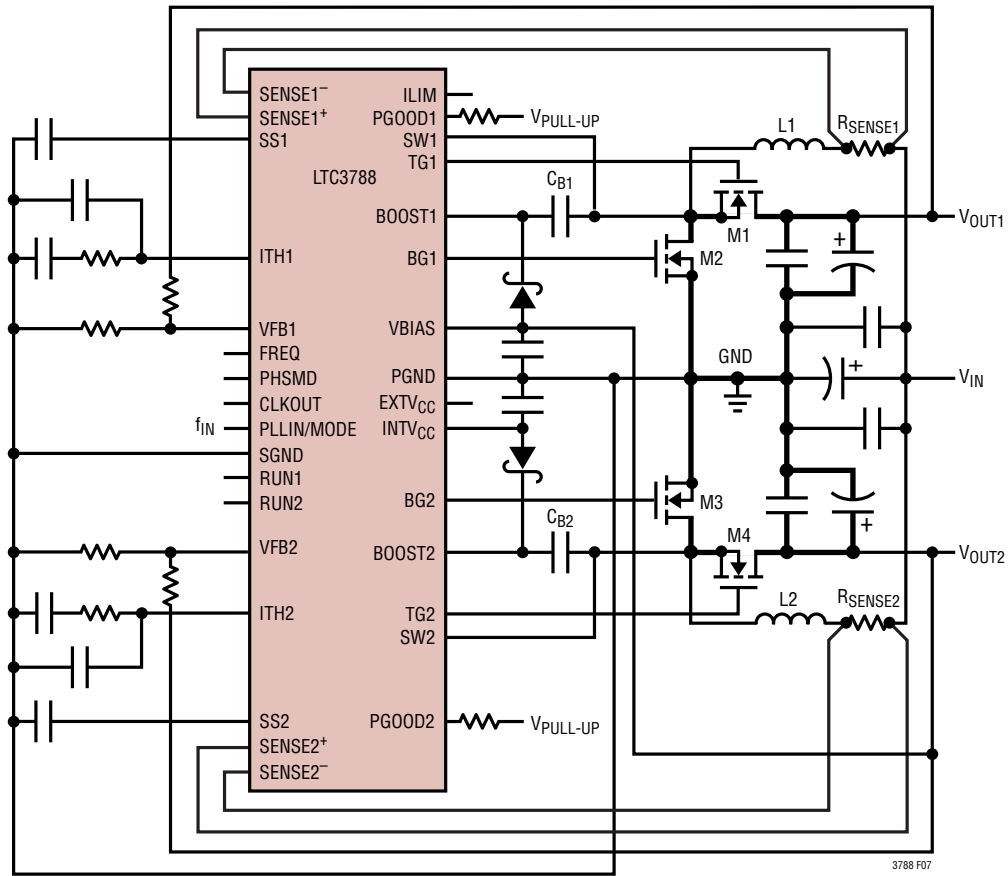

Figure 7. Recommended Printed Circuit Layout Diagram

# APPLICATIONS INFORMATION

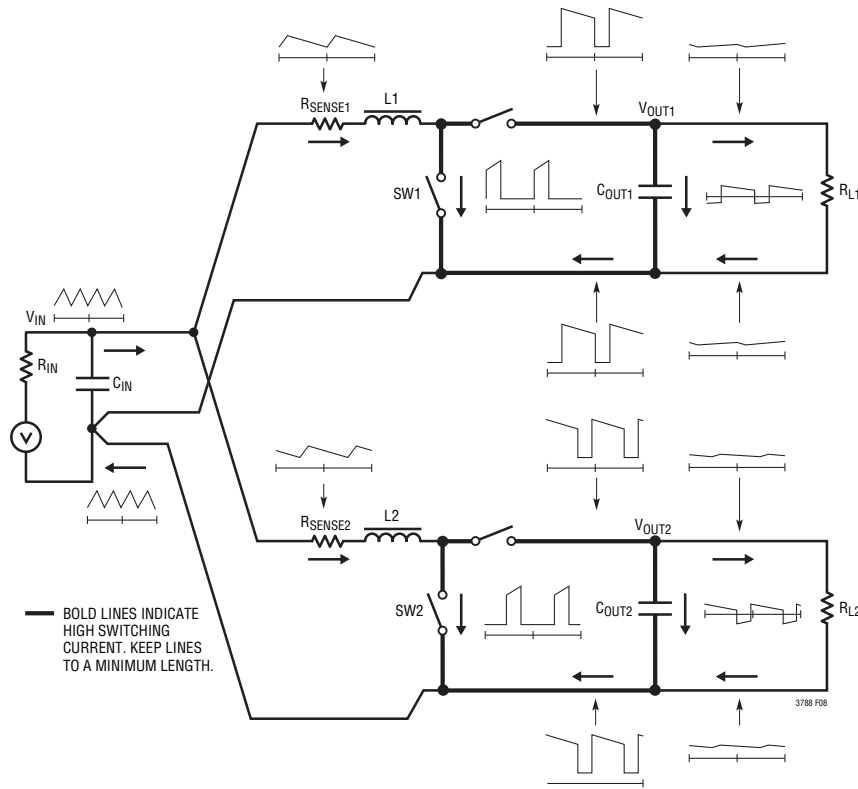
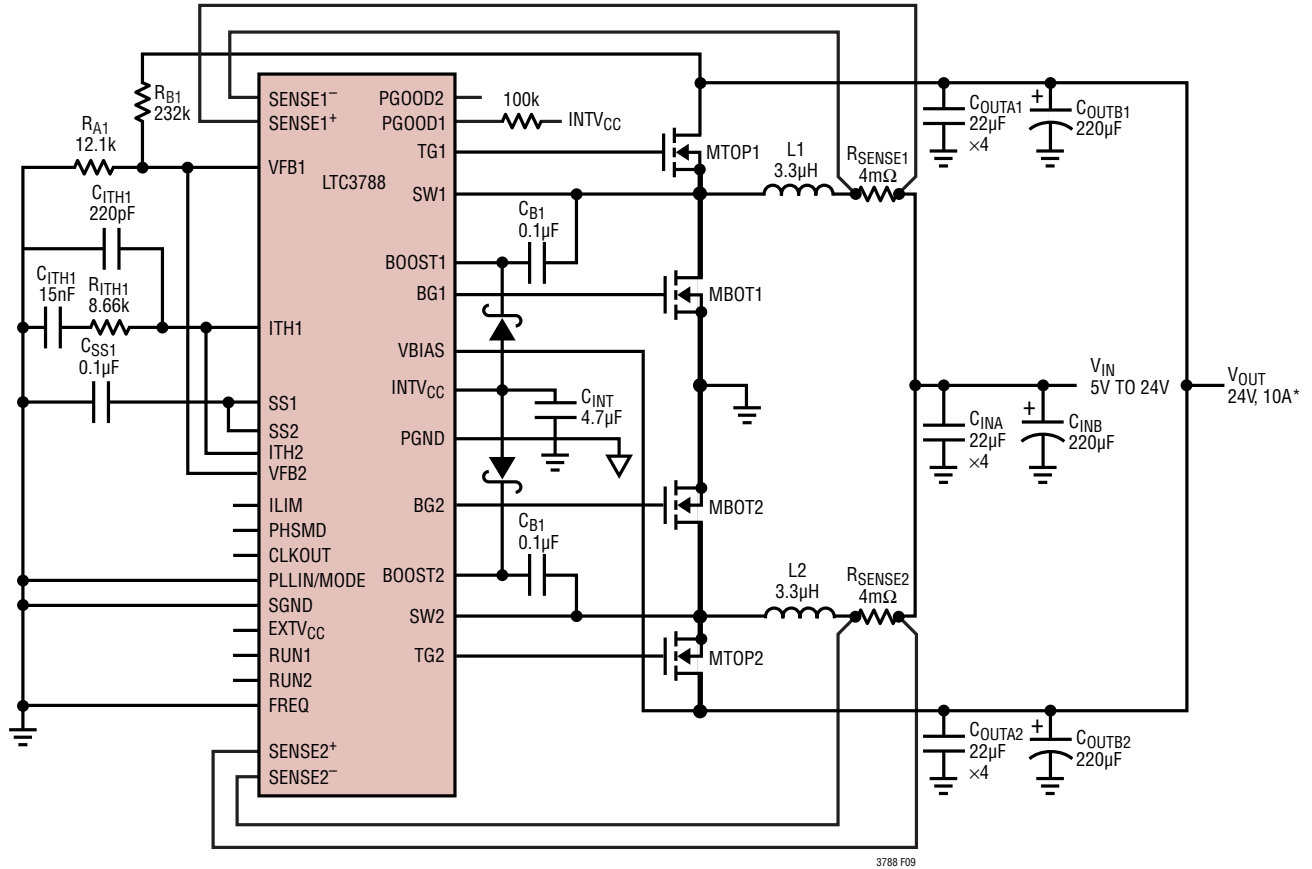

Figure 8. Branch Current Waveforms

APPLICATIONS INFORMATION



CINA, COUTA1, COUTA2: SANYO, 50CE220AX  
 CINB, COUTB1, COUTB2: TDK G4532X5R1E226M  
 L1, L2: PULSE PA1494.362NL  
 MBOT1, MBOT2, MTOP1, MTOP2: RENESAS HAT2169H  
 \*WHEN  $V_{IN} < 8V$ , MAXIMUM LOAD CURRENT AVAILABLE IS REDUCED.

Figure 9. High Efficiency 2-Phase 24V Boost Converter

APPLICATIONS INFORMATION

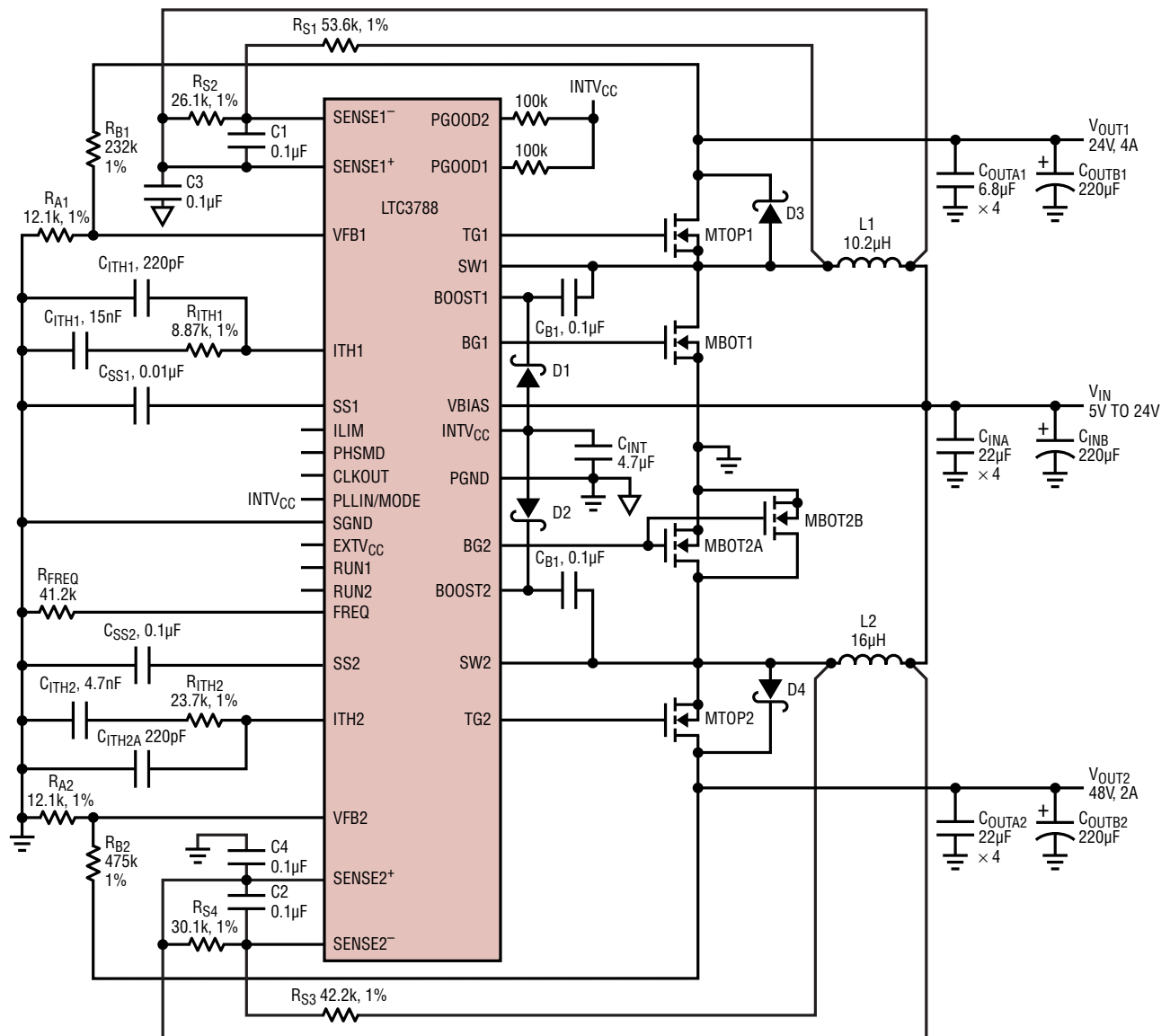

- C<sub>OUTA2</sub>: C4532x7R1H685K
- C<sub>OUTB2</sub>: SANYO 63CE220KX
- C<sub>INA</sub>, C<sub>OUTA1</sub>: TDK C4532X5R1E226M
- C<sub>INB</sub>, C<sub>OUTB1</sub>: SANYO 50CE220AX
- L1: PULSE PA2050.103NL
- L2: PULSE PA2050.163NL
- MBOT1, MTOP1: RENESAS RJK0305
- MBOT2A, MBOT2B, MTOP2: RENESAS RJK0652
- D3: DIODES INC B340B
- D4: DIODES INC B360A

Figure 10. High Efficiency Dual 24V/48V Boost Converter with Inductor DCR Current Sensing

## PACKAGE DESCRIPTION

Please refer to <http://www.linear.com/designtools/packaging/> for the most recent package drawings.

### UH Package 32-Lead Plastic QFN (5mm × 5mm) (Reference LTC DWG # 05-08-1693 Rev D)

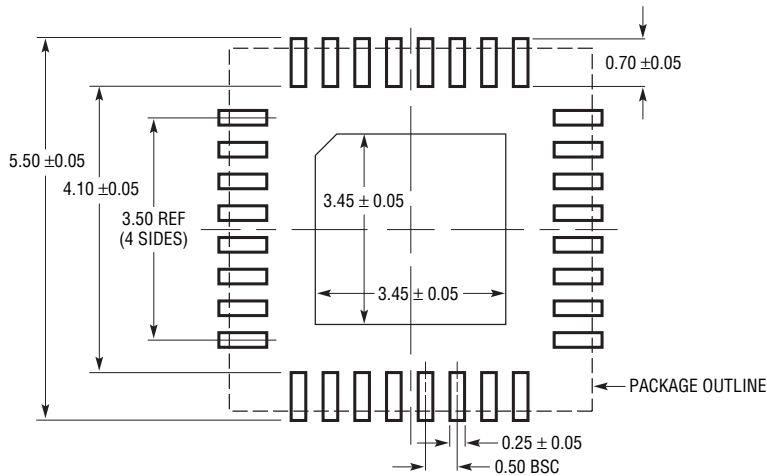

RECOMMENDED SOLDER PAD LAYOUT  
APPLY SOLDER MASK TO AREAS THAT ARE NOT SOLDERED

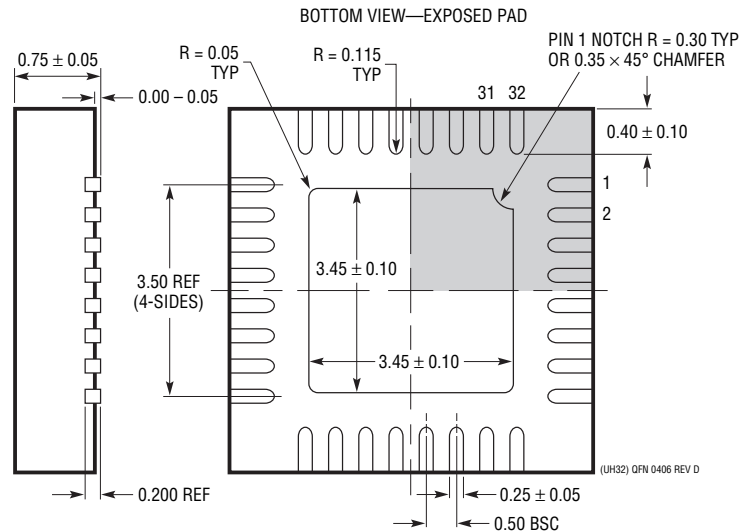
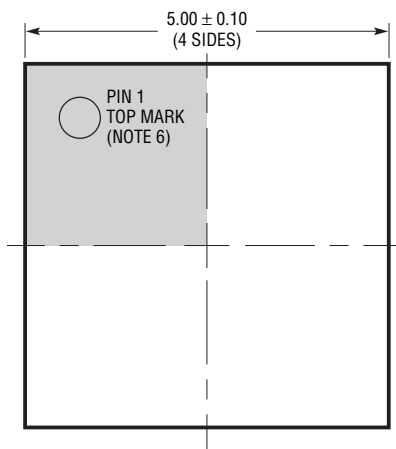

NOTE:

1. DRAWING PROPOSED TO BE A JEDEC PACKAGE OUTLINE  
MO-220 VARIATION WHHD-(X) (TO BE APPROVED)
2. DRAWING NOT TO SCALE
3. ALL DIMENSIONS ARE IN MILLIMETERS
4. DIMENSIONS OF EXPOSED PAD ON BOTTOM OF PACKAGE DO NOT INCLUDE  
MOLD FLASH. MOLD FLASH, IF PRESENT, SHALL NOT EXCEED 0.20mm ON ANY SIDE
5. EXPOSED PAD SHALL BE SOLDER PLATED
6. SHADED AREA IS ONLY A REFERENCE FOR PIN 1 LOCATION  
ON THE TOP AND BOTTOM OF PACKAGE

## REVISION HISTORY

REV	DATE	DESCRIPTION	PAGE NUMBER
A	4/10	Updates to Typical Application.	1
		Updates in the Electrical Characteristics Section.	3, 4
		Updates to PLLIN/MODE in Pin Functions.	9
		Updates to Application Information.	21, 24
		New Figure 9 Added.	28
		Updated Note on Typical Application.	32
		Updated Related Parts Table.	32
B	9/11	Updated the Topside MOSFET Driver Supply ( $C_B$ , $D_B$ ) section.	21
		Updated the Related Parts.	32
C	1/12	Revised Figure 10	29

## TYPICAL APPLICATION

### High Efficiency Dual 12V/24V Boost Converter

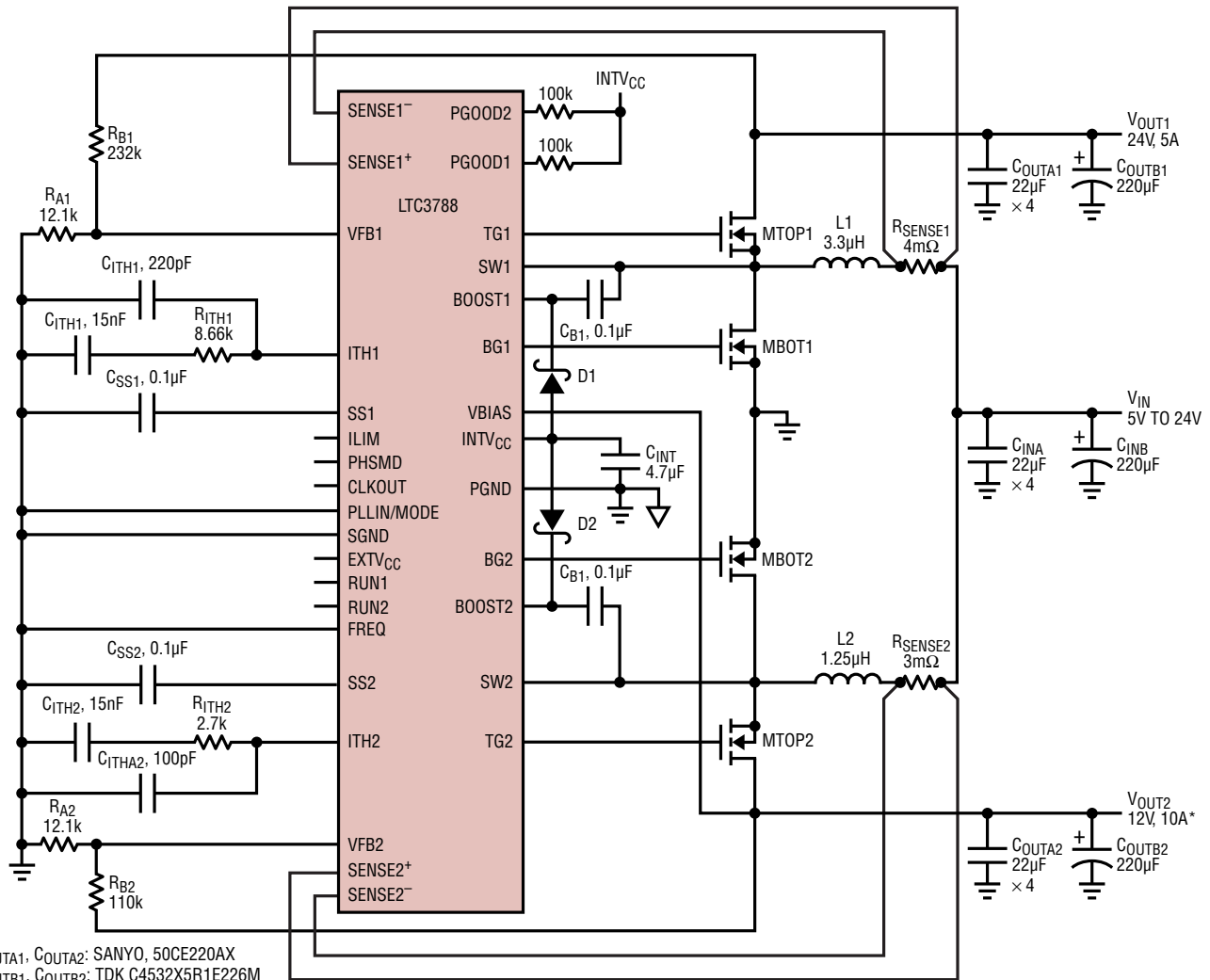

C<sub>INA</sub>, C<sub>OUTA1</sub>, C<sub>OUTA2</sub>: SANYO, 50CE220AX  
 C<sub>INB</sub>, C<sub>OUTB1</sub>, C<sub>OUTB2</sub>: TDK C4532X5R1E226M  
 L1: PULSE PA1494.362NL  
 L2: PULSE PA1294.132NL  
 MBOT1, MBOT2, MTOP1, MTOP2: RENESAS HAT2169H  
 \* WHEN V<sub>IN</sub> = 8V, MAXIMUM LOAD CURRENT AVAILABLE IS REDUCED. V<sub>OUT2</sub> FOLLOWS V<sub>IN</sub> WHEN V<sub>IN</sub> > 12V.

3788 TA02

## RELATED PARTS

PART NUMBER	DESCRIPTION	COMMENTS
LTC3787/LTC3787-1	Multiphase, Dual Channel Synchronous Step-Up Controller	4.5V (Down to 2.5V After Start-Up) ≤ V <sub>IN</sub> ≤ 38V, V <sub>OUT</sub> Up to 60V, 50kHz to 900kHz Fixed Operating Frequency, 4mm × 5mm QFN-28, SSOP-28
LTC3786	Low I <sub>Q</sub> Synchronous Step-Up Controller	4.5V (Down to 2.5V After Start-Up) ≤ V <sub>IN</sub> ≤ 38V, V <sub>OUT</sub> Up to 60V, 50kHz to 900kHz Fixed Operating Frequency, 3mm × 3mm QFN-32, MSOP-16E
LTC3862/LTC3862-1	Multiphase, Dual Channel Single Output Current Mode Step-Up DC/DC Controller	4V ≤ V <sub>IN</sub> ≤ 36V, 5V or 10V Gate Drive, 75kHz to 500kHz Fixed Operating Frequency, SSOP-24, TSSOP-24, 5mm × 5mm QFN-24
LTC3859A	Low I <sub>Q</sub> , Triple Output Buck/Buck/Boost Synchronous DC/DC Controller	All Outputs Remain in Regulation Through Cold Crank, 4.5V (Down to 2.5V After Start-Up) ≤ V <sub>IN</sub> ≤ 38V, V <sub>OUT(BUCK)</sub> Up to 24V, V <sub>OUT(BOOST)</sub> Up to 60V, I <sub>Q</sub> = 55µA
LTC3789	High Efficiency Synchronous 4-Switch Buck-Boost DC/DC Controller	4V ≤ V <sub>IN</sub> ≤ 38V, 0.8V ≤ V <sub>OUT</sub> ≤ 38V, SSOP-28, 4mm × 5mm QFN-28, SSOP-28

3788fc

## Looking for pricing, stock, or lifecycle information?

Click below to explore more details on WIN SOURCE:

 [View LTC3788EUH#PBF on WIN SOURCE](#)

 [Linear Technology](#) Information

## Optimize Your Supply Chain with WIN SOURCE Solutions

-  Global Sourcing Solution
-  Obsolete Management
-  Cost Control Management
-  Shortage Management
-  Alternative Solution
-  Excess Inventory Management