



**THE DATASHEET OF  
LTC3830EGN#PBF**



# High Power Step-Down Synchronous DC/DC Controllers for Low Voltage Operation

## FEATURES

- High Power Switching Regulator Controller for 3.3V-5V to 1.xV-3.xV Step-Down Applications
- No Current Sense Resistor Required
- Low Input Supply Voltage Range: 3V to 8V
- Maximum Duty Cycle >91% Over Temperature
- All N-Channel External MOSFETs
- Excellent Output Regulation:  $\pm 1\%$  Over Line, Load and Temperature Variations
- High Efficiency: Over 95% Possible
- Adjustable or Fixed 3.3V Output (16-Pin Version)
- Programmable Fixed Frequency Operation: 100kHz to 500kHz
- External Clock Synchronization
- Soft-Start (16-Pin Version and LTC3830-1)
- Low Shutdown Current:  $< 10\mu\text{A}$
- Overtemperature Protection
- Available in S8, S16 and SSOP-16 Packages

## APPLICATIONS

- CPU Power Supplies
- Multiple Logic Supply Generator
- Distributed Power Applications
- High Efficiency Power Conversion

## DESCRIPTION

The LTC<sup>®</sup>3830/LTC3830-1 are high power, high efficiency switching regulator controllers optimized for 3.3V-5V to 1.xV-3.xV step-down applications. A precision internal reference and feedback system provide  $\pm 1\%$  output regulation over temperature, load current and line voltage variations. The LTC3830/LTC3830-1 use a synchronous switching architecture with N-channel MOSFETs. Additionally, the chip senses output current through the drain-source resistance of the upper N-channel FET, providing an adjustable current limit without a current sense resistor.

The LTC3830/LTC3830-1 operate with an input supply voltage as low as 3V and with a maximum duty cycle of >91% over temperature. They include a fixed frequency PWM oscillator for low output ripple operation. The 200kHz free-running clock frequency can be externally adjusted or synchronized with an external signal from 100kHz to 500kHz. In shutdown mode, the LTC3830 supply current drops to  $< 10\mu\text{A}$ . The LTC3830-1 differs from the LTC3830 S8 version by replacing shutdown with a soft-start function.

For a similar, pin compatible DC/DC converter with an output voltage as low as 0.6V, please refer to the LTC3832.

 LTC and LT are registered trademarks of Linear Technology Corporation.

## TYPICAL APPLICATION

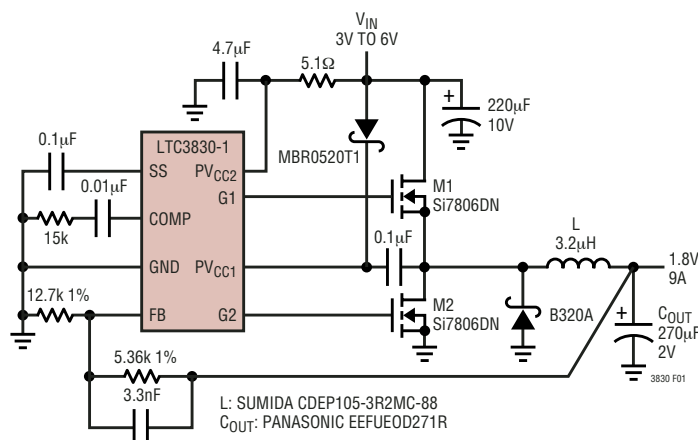
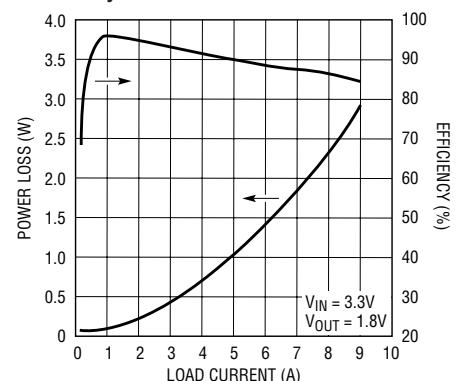

Figure 1. High Efficiency 3V-6V to 1.8V Power Converter

### Efficiency and Power Loss vs Load Current



3830 TA02

# LTC3830/LTC3830-1

## ABSOLUTE MAXIMUM RATINGS (Note 1)

Supply Voltage	Junction Temperature (Note 11).....	125°C
$V_{CC}$ .....	Operating Temperature Range (Note 9) ..	-40°C to 85°C
$PV_{CC1,2}$ .....	Storage Temperature Range .....	-65°C to 150°C
Input Voltage	Lead Temperature (Soldering, 10 sec).....	300°C
$I_{FB}, I_{MAX}$ .....		
$SENSE^+, SENSE^-, FB,$		
$SHDN, FREQSET$ .....		
		-0.3V to 14V
		-0.3V to $V_{CC} + 0.3V$

## PACKAGE/ORDER INFORMATION

<p>S8 PACKAGE 8-LEAD PLASTIC SO <math>T_{JMAX} = 125^{\circ}C, \theta_{JA} = 130^{\circ}C/W</math></p>	ORDER PART NUMBER	<p>GN PACKAGE      S PACKAGE 16-LEAD PLASTIC SSOP   16-LEAD PLASTIC SO <math>T_{JMAX} = 125^{\circ}C, \theta_{JA} = 130^{\circ}C/W</math> (GN) <math>T_{JMAX} = 125^{\circ}C, \theta_{JA} = 100^{\circ}C/W</math> (S)</p>	ORDER PART NUMBER
	LTC3830ES8		LTC3830EGN LTC3830ES
	S8 PART MARKING		GN PART MARKING
	3830		3830
<p>S8 PACKAGE 8-LEAD PLASTIC SO <math>T_{JMAX} = 125^{\circ}C, \theta_{JA} = 130^{\circ}C/W</math></p>	ORDER PART NUMBER		
	LTC3830-1ES8		
	S8 PART MARKING		
	38301		

Consult LTC Marketing for parts specified with wider operating temperature ranges.

## ELECTRICAL CHARACTERISTICS

The ● denotes specifications that apply over the full operating temperature range, otherwise specifications are at  $T_A = 25^{\circ}C$ .  $V_{CC}, PV_{CC1}, PV_{CC2} = 5V$ , unless otherwise noted. (Note 2)

SYMBOL	PARAMETER	CONDITIONS	MIN	TYP	MAX	UNITS
$V_{CC}$	Supply Voltage		● 3	5	8	V
$PV_{CC}$	$PV_{CC1}, PV_{CC2}$ Voltage	(Note 7)	● 3		13.2	V
$V_{UVLO}$	Undervoltage Lockout Voltage			2.4	2.9	V
$V_{FB}$	Feedback Voltage	$V_{COMP} = 1.25V$	● 1.255	1.265	1.275	V
			● 1.252	1.265	1.278	V
$V_{OUT}$	Output Voltage	$V_{COMP} = 1.25V$	● 3.250	3.3	3.350	V
			● 3.235	3.3	3.365	V
$\Delta V_{OUT}$	Output Load Regulation Output Line Regulation	$I_{OUT} = 0A$ to 10A (Note 6) $V_{CC} = 4.75V$ to 5.25V		2		mV
				0.1		mV

3830fa

## ELECTRICAL CHARACTERISTICS

The ● denotes specifications that apply over the full operating temperature range, otherwise specifications are at  $T_A = 25^\circ\text{C}$ .  $V_{CC}$ ,  $PV_{CC1}$ ,  $PV_{CC2} = 5\text{V}$ , unless otherwise noted. (Note 2)

SYMBOL	PARAMETER	CONDITIONS		MIN	TYP	MAX	UNITS
$I_{VCC}$	Supply Current	Figure 2, $V_{\overline{\text{SHDN}}} = V_{CC}$ $V_{\overline{\text{SHDN}}} = 0\text{V}$	● ●		0.7 1	1.6 10	 mA  μA
$I_{PVCC}$	$PV_{CC}$ Supply Current	Figure 2, $V_{\overline{\text{SHDN}}} = V_{CC}$ (Note 3) $V_{\overline{\text{SHDN}}} = 0\text{V}$	● ●		14 0.1	20 10	 mA  μA
$f_{OSC}$	Internal Oscillator Frequency	FREQSET Floating	●	160	200	250	kHz
$V_{SAWL}$	$V_{COMP}$ at Minimum Duty Cycle				1.2		V
$V_{SAWH}$	$V_{COMP}$ at Maximum Duty Cycle				2.2		V
$V_{COMPMAX}$	Maximum $V_{COMP}$	$V_{FB} = 0\text{V}$ , $PV_{CC1} = 8\text{V}$			2.85		V
$\Delta f_{OSC}/\Delta I_{FREQSET}$	Frequency Adjustment				10		kHz/μA
$A_V$	Error Amplifier Open-Loop DC Gain	Measured from FB to COMP, SENSE+ and SENSE- Floating, (Note 4)	●	46	55		dB
$g_m$	Error Amplifier Transconductance	Measured from FB to COMP, SENSE+ and SENSE- Floating, (Note 4)	●	520	650	780	μmho
$I_{COMP}$	Error Amplifier Output Sink/Source Current				100		μA
$I_{MAX}$	$I_{MAX}$ Sink Current	$V_{IMAX} = V_{CC}$ (Note 10)	●	9 4	12 12	15 20	 μA μA
	$I_{MAX}$ Sink Current Tempco	$V_{IMAX} = V_{CC}$ (Note 6)			3300		ppm/°C
$V_{IH}$	$\overline{\text{SHDN}}$ Input High Voltage		●	2.4			V
$V_{IL}$	$\overline{\text{SHDN}}$ Input Low Voltage		●			0.8	V
$I_{IN}$	$\overline{\text{SHDN}}$ Input Current	$V_{\overline{\text{SHDN}}} = V_{CC}$	●		0.1	1	μA
$I_{SS}$	Soft-Start Source Current	$V_{SS} = 0\text{V}$ , $V_{IMAX} = 0\text{V}$ , $V_{IFB} = V_{CC}$	●	-8	-12	-16	μA
$I_{SSIL}$	Maximum Soft-Start Sink Current In Current Limit	$V_{IMAX} = V_{CC}$ , $V_{IFB} = 0\text{V}$ , $V_{SS} = V_{CC}$ (Note 8), $PV_{CC1} = 8\text{V}$			1.6		mA
$R_{SENSE}$	SENSE Input Resistance				29.2		kΩ
$R_{SENSEFB}$	SENSE to FB Resistance				18		kΩ
$t_r, t_f$	Driver Rise/Fall Time	Figure 3, $PV_{CC1} = PV_{CC2} = 5\text{V}$ (Note 5)	●		80	250	ns
$t_{NOV}$	Driver Nonoverlap Time	Figure 3, $PV_{CC1} = PV_{CC2} = 5\text{V}$ (Note 5)	●	25	120	250	ns
$DC_{MAX}$	Maximum G1 Duty Cycle	Figure 3, $V_{FB} = 0\text{V}$ (Note 5), $PV_{CC1} = 8\text{V}$	●	91	95		%

**Note 1:** Absolute Maximum Ratings are those values beyond which the life of a device may be impaired.

**Note 2:** All currents into device pins are positive; all currents out of device pins are negative. All voltages are referenced to ground unless otherwise specified.

**Note 3:** Supply current in normal operation is dominated by the current needed to charge and discharge the external FET gates. This will vary with the LTC3830 operating frequency, operating voltage and the external FETs used.

**Note 4:** The open-loop DC gain and transconductance from the SENSE+ and SENSE- pins to COMP pin will be  $(A_V)(1.265/3.3)$  and  $(g_m)(1.265/3.3)$  respectively.

**Note 5:** Rise and fall times are measured using 10% and 90% levels. Duty cycle and nonoverlap times are measured using 50% levels.

**Note 6:** Guaranteed by design, not subject to test.

**Note 7:**  $PV_{CC1}$  must be higher than  $V_{CC}$  by at least 2.5V for G1 to operate at 95% maximum duty cycle and for the current limit protection circuit to be active.

**Note 8:** The current limiting amplifier can sink but cannot source current. Under normal (not current limited) operation, the output current will be zero.

**Note 9:** The LTC3830E/LTC3830-1E are guaranteed to meet performance specifications from  $0^\circ\text{C}$  to  $70^\circ\text{C}$ . Specifications over the  $-40^\circ\text{C}$  to  $85^\circ\text{C}$  operating temperature range are assured by design, characterization and correlation with statistical process controls.

**Note 10:** The minimum and maximum limits for  $I_{MAX}$  over temperature includes the intentional temperature coefficient of 3300ppm/°C. This induced temperature coefficient counteracts the typical temperature coefficient of the external power MOSFET on-resistance. This results in a relatively flat current limit over temperature for the application.

**Note 11:** This IC includes overtemperature protection that is intended to protect the device during momentary overload conditions. Junction temperature will exceed  $125^\circ\text{C}$  when overtemperature protection is active. Continuous operation above the specified maximum operating temperature may impair device reliability.

# TYPICAL PERFORMANCE CHARACTERISTICS

**Load Regulation**

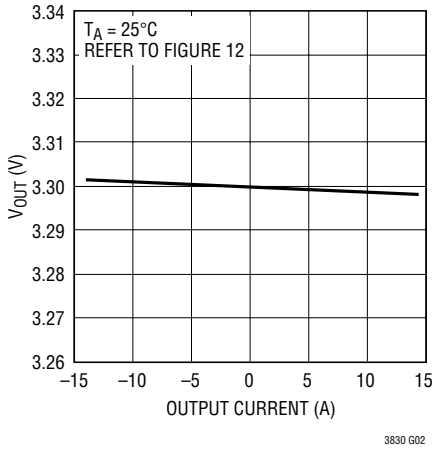

**Line Regulation**

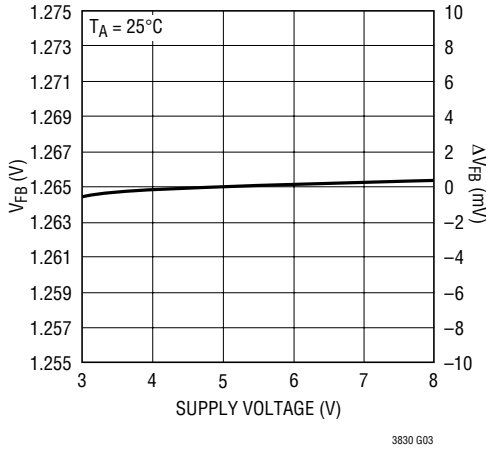

**Error Amplifier Transconductance vs Temperature**

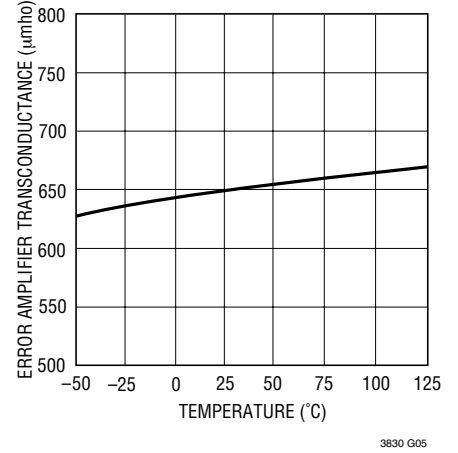

**Output Voltage Temperature Drift**

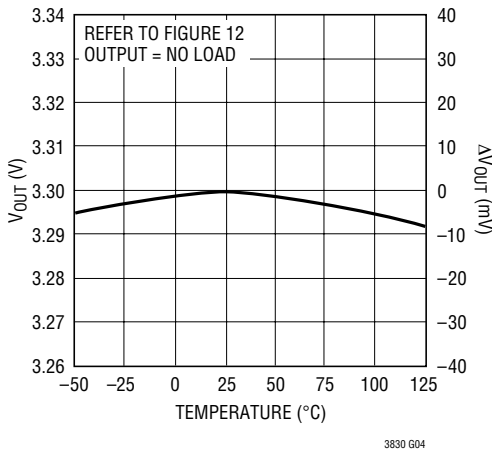

**Error Amplifier Sink/Source Current vs Temperature**

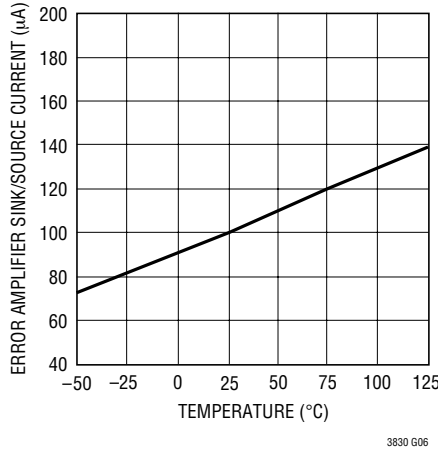

**Error Amplifier Open-Loop Gain vs Temperature**

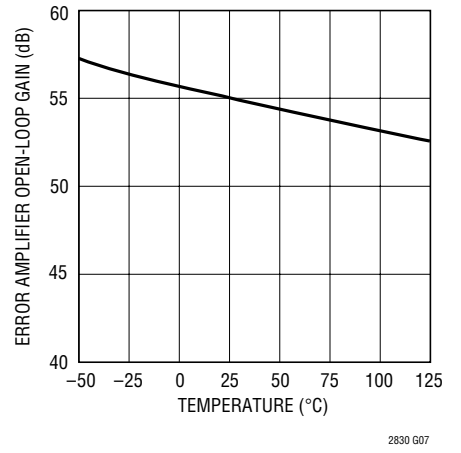

**Oscillator Frequency vs Temperature**

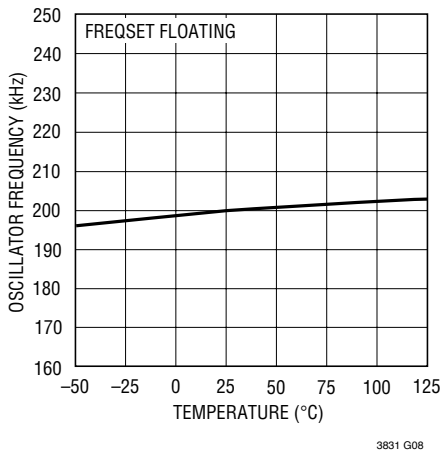

**Oscillator Frequency vs FREQSET Input Current**

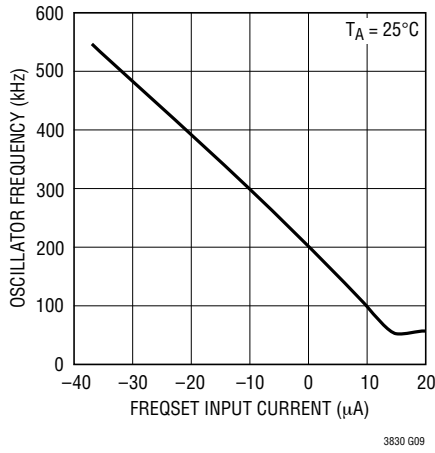

**Oscillator ( $V_{SAWH} - V_{SAWL}$ ) vs External Sync Frequency**

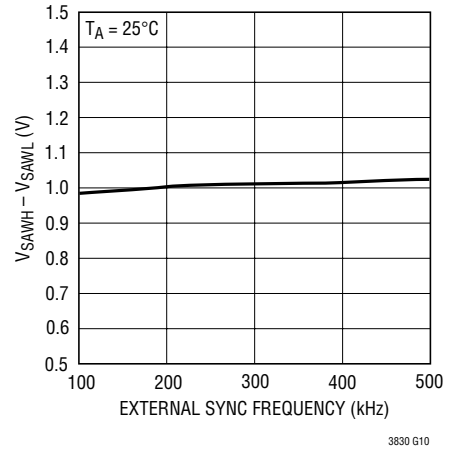

# TYPICAL PERFORMANCE CHARACTERISTICS

**Maximum G1 Duty Cycle vs Temperature**

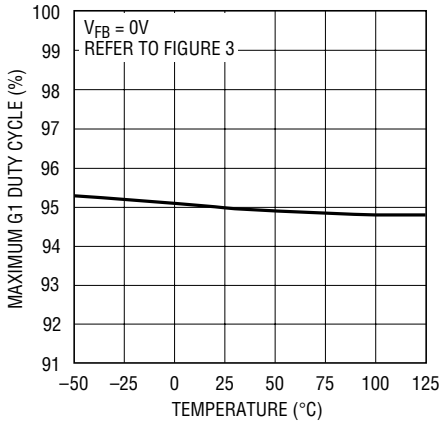

3830 G11

**I<sub>MAX</sub> Sink Current vs Temperature**

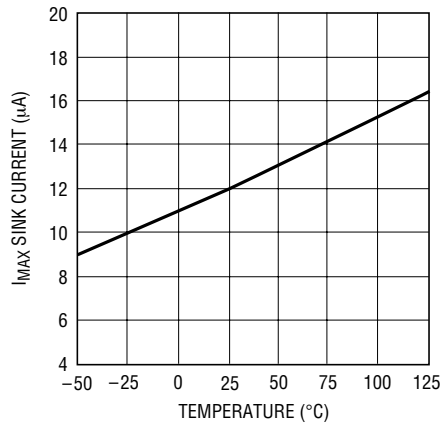

3830 G12

**Output Overcurrent Protection**

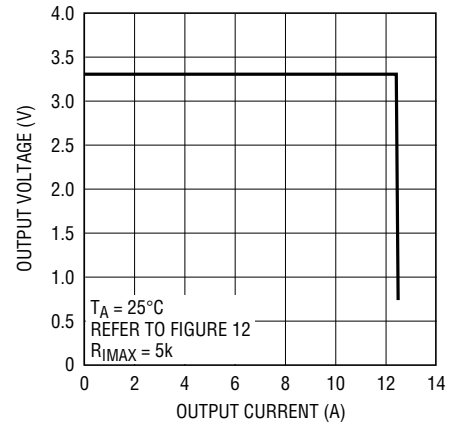

3830 G13

**Output Current Limit Threshold vs Temperature**

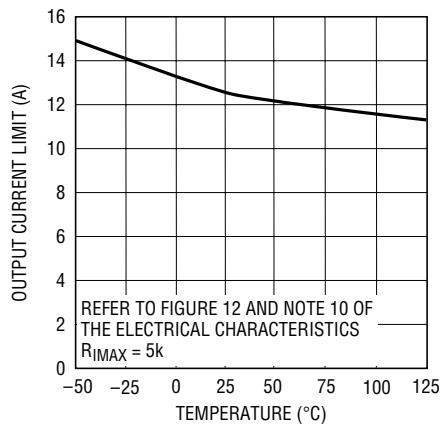

3830 G14

**Soft-Start Source Current vs Temperature**

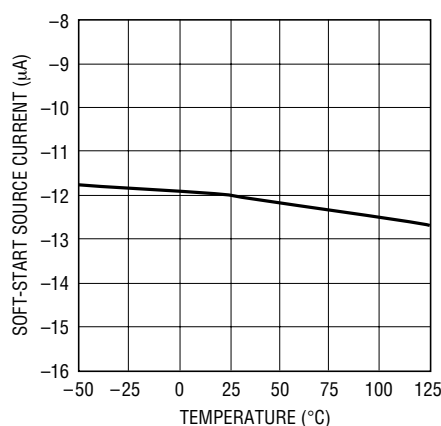

3830 G15

**Soft-Start Sink Current vs (V<sub>FB</sub> - V<sub>IMAX</sub>)**

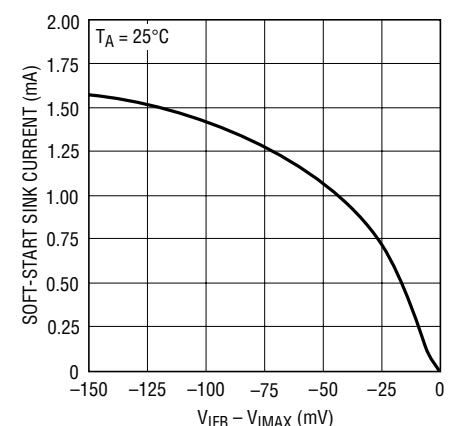

3830 G16

**Undervoltage Lockout Threshold Voltage vs Temperature**

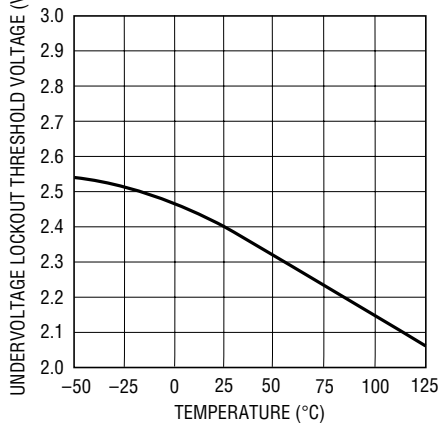

3830 G17

**V<sub>CC</sub> Operating Supply Current vs Temperature**

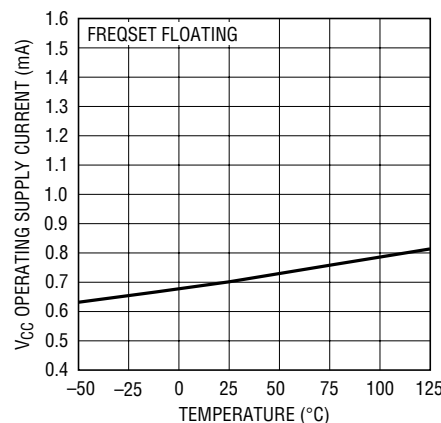

3830 G18

**PV<sub>CC</sub> Supply Current vs Oscillator Frequency**

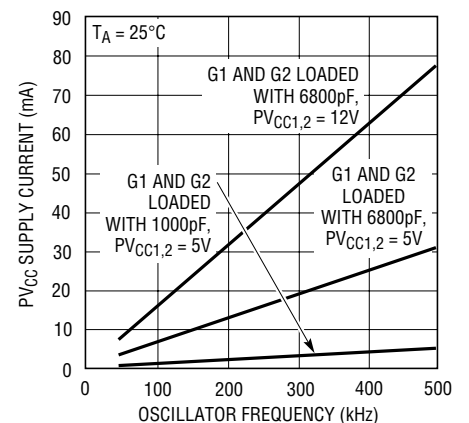

3830 G19

## TYPICAL PERFORMANCE CHARACTERISTICS

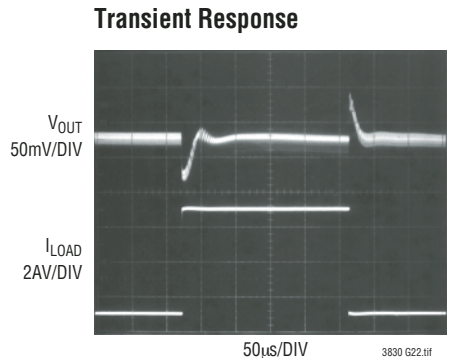
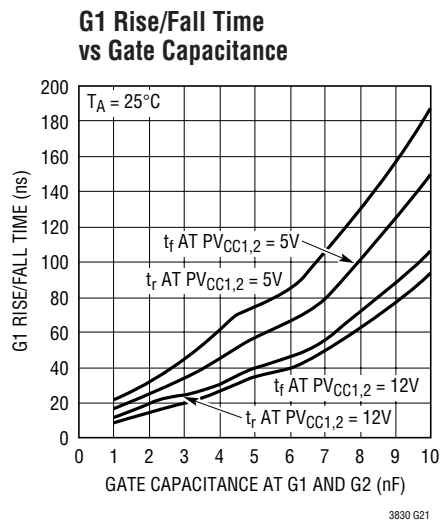
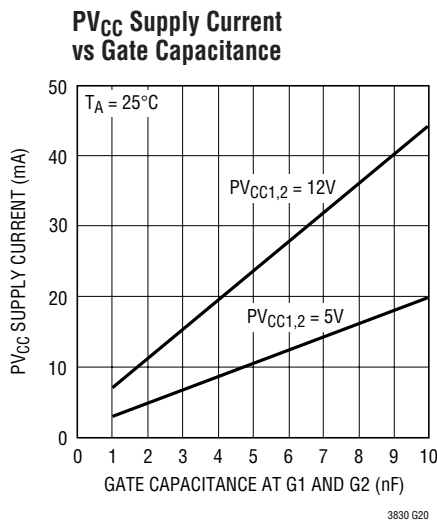

## PIN FUNCTIONS (16-Lead LTC3830/8-Lead LTC3830/LTC3830-1)

**G1 (Pin 1/Pin 1/Pin 1):** Top Gate Driver Output. Connect this pin to the gate of the upper N-channel MOSFET, Q1. This output swings from PGND to PV<sub>CC1</sub>. It remains low if G2 is high or during shutdown mode.

**PV<sub>CC1</sub> (Pin 2/Pin 2/Pin 2):** Power Supply Input for G1. Connect this pin to a potential of at least V<sub>IN</sub> + V<sub>GS(ON)(Q1)</sub>. This potential can be generated using an external supply or charge pump.

**PGND (Pin 3/Pin 3/Pin 3):** Power Ground. Both drivers return to this pin. Connect this pin to a low impedance ground in close proximity to the source of Q2. Refer to the Layout Consideration section for more details on PCB layout techniques. The LTC3830-1 and the 8-lead LTC3830 have PGND and GND tied together internally at Pin 3.

**GND (Pin 4/Pin 3/Pin 3):** Signal Ground. All low power internal circuitry returns to this pin. To minimize regulation errors due to ground currents, connect GND to PGND right at the LTC3830.

**SENSE<sup>-</sup>, FB, SENSE<sup>+</sup> (Pins 5, 6, 7/Pin 4/Pin 4):** These three pins connect to the internal resistor divider and input of the error amplifier. To use the internal divider to set the output voltage to 3.3V, connect SENSE<sup>+</sup> to the positive terminal of the output capacitor and SENSE<sup>-</sup> to the negative terminal. FB should be left floating. To use an external

resistor divider to set the output voltage, float SENSE<sup>+</sup> and SENSE<sup>-</sup> and connect the external resistor divider to FB. The internal resistor divider is not included in the LTC3830-1 and the 8-lead LTC3830.

**SHDN (Pin 8/Pin 5/NA):** Shutdown. A TTL compatible low level at SHDN for longer than 100μs puts the LTC3830 into shutdown mode. In shutdown, G1 and G2 go low, all internal circuits are disabled and the quiescent current drops to 10μA max. A TTL compatible high level at SHDN allows the part to operate normally. This pin also doubles as an external clock input to synchronize the internal oscillator with an external clock. The shutdown function is disabled in the LTC3830-1.

**SS (Pin 9/NA/Pin 5):** Soft-Start. Connect this pin to an external capacitor, C<sub>SS</sub>, to implement a soft-start function. If the LTC3830 goes into current limit, C<sub>SS</sub> is discharged to reduce the duty cycle. C<sub>SS</sub> must be selected such that during power-up, the current through Q1 will not exceed the current limit level. The soft-start function is disabled in the 8-lead LTC3830.

**COMP (Pin 10/Pin 6/Pin 6):** External Compensation. This pin internally connects to the output of the error amplifier and input of the PWM comparator. Use a RC + C network at this pin to compensate the feedback loop to provide optimum transient response.

## PIN FUNCTIONS

**FREQSET (Pin 11/NA/NA):** Frequency Set. Use this pin to adjust the free-running frequency of the internal oscillator. With the pin floating, the oscillator runs at about 200kHz. A resistor from FREQSET to ground speeds up the oscillator; a resistor to  $V_{CC}$  slows it down.

**$I_{MAX}$  (Pin 12/NA/NA):** Current Limit Threshold Set.  $I_{MAX}$  sets the threshold for the internal current limit comparator. If  $I_{FB}$  drops below  $I_{MAX}$  with G1 on, the LTC3830 goes into current limit.  $I_{MAX}$  has an internal 12 $\mu$ A pull-down to GND. Connect this pin to the main  $V_{IN}$  supply at the drain of Q1, through an external resistor to set the current limit threshold. Connect a 0.1 $\mu$ F decoupling capacitor across this resistor to filter switching noise.

**$I_{FB}$  (Pin 13/NA/NA):** Current Limit Sense. Connect this pin to the switching node at the source of Q1 and the drain of Q2 through a 1k resistor. The 1k resistor is required to prevent voltage transients from damaging  $I_{FB}$ . This pin is used for sensing the voltage drop across the upper N-channel MOSFET, Q1.

**$V_{CC}$  (Pin 14/Pin 7/Pin 7):** Power Supply Input. All low power internal circuits draw their supply from this pin. Connect this pin to a clean power supply, separate from the main  $V_{IN}$  supply at the drain of Q1. This pin requires a 4.7 $\mu$ F bypass capacitor. The LTC3830-1 and the 8-lead LTC3830 have  $V_{CC}$  and  $PV_{CC2}$  tied together at Pin 7 and require a 10 $\mu$ F bypass capacitor to GND.

**$PV_{CC2}$  (Pin 15/Pin 7/Pin 7):** Power Supply Input for G2. Connect this pin to the main high power supply.

**G2 (Pin 16/Pin 8/Pin 8):** Bottom Gate Driver Output. Connect this pin to the gate of the lower N-channel MOSFET, Q2. This output swings from PGND to  $PV_{CC2}$ . It remains low when G1 is high or during shutdown mode. To prevent output undershoot during a soft-start cycle, G2 is held low until G1 first goes high. (FFBG in Block Diagram.)

## BLOCK DIAGRAM

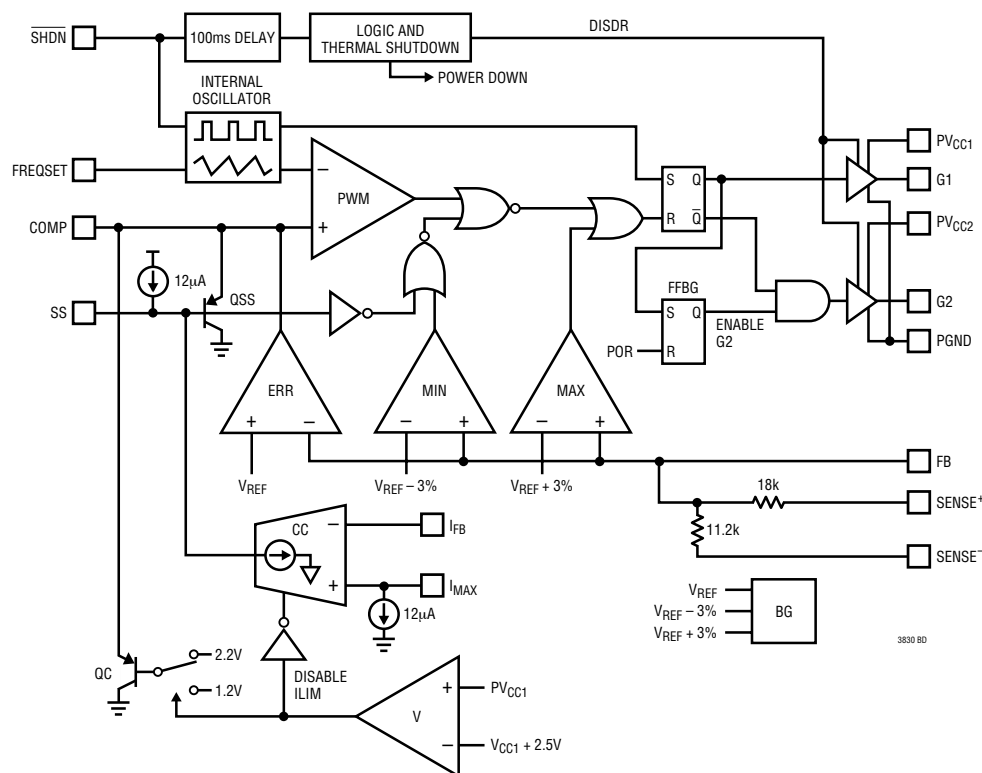

3830fa

## TEST CIRCUITS

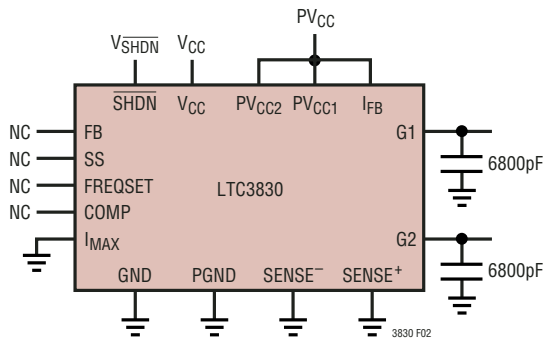

Figure 2

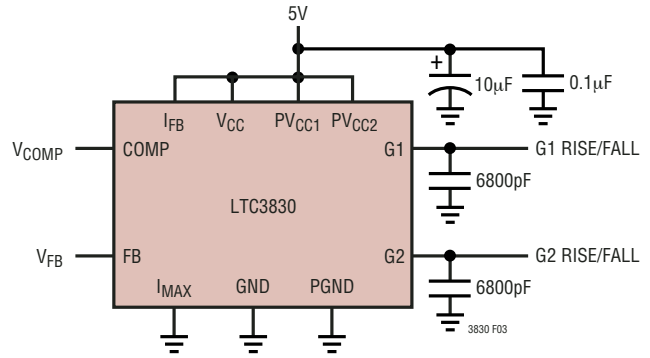

Figure 3

## APPLICATIONS INFORMATION

### OVERVIEW

The LTC3830 is a voltage mode feedback, synchronous switching regulator controller (see Block Diagram) designed for use in high power, low voltage step-down (buck) converters. It includes an onboard PWM generator, a precision reference trimmed to  $\pm 0.8\%$ , two high power MOSFET gate drivers and all necessary feedback and control circuitry to form a complete switching regulator circuit. The PWM loop nominally runs at 200kHz.

The 16-lead versions of the LTC3830 include a current limit sensing circuit that uses the topside external N-channel power MOSFET as a current sensing element, eliminating the need for an external sense resistor.

Also included in the 16-lead version and the LTC3830-1 is an internal soft-start feature that requires only a single external capacitor to operate. In addition, 16-lead parts feature an adjustable oscillator that can free run or synchronize to external signal with frequencies from 100kHz to 500kHz, allowing added flexibility in external component selection. The 8-lead version does not include current limit, internal soft-start and frequency adjustability. The LTC3830-1 does not include current limit, frequency adjustability, external synchronization and the shutdown function.

### THEORY OF OPERATION

#### Primary Feedback Loop

The LTC3830/LTC3830-1 sense the output voltage of the circuit at the output capacitor and feeds this voltage back to the internal transconductance error amplifier, ERR, through a resistor divider network. The error amplifier compares the resistor-divided output voltage to the internal 1.265V reference and outputs an error signal to the PWM comparator. This error signal is compared with a fixed frequency ramp waveform, from the internal oscillator, to generate a pulse width modulated signal. This PWM signal drives the external MOSFETs through the G1 and G2 pins. The resulting chopped waveform is filtered by  $L_O$  and  $C_{OUT}$  which closes the loop. Loop compensation is achieved with an external compensation network at the COMP pin, the output node of the error amplifier.

#### MIN, MAX Feedback Loops

Two additional comparators in the feedback loop provide high speed output voltage correction in situations where the error amplifier may not respond quickly enough. MIN compares the feedback signal to a voltage 40mV below the internal reference. If the signal is below the comparator threshold, the MIN comparator overrides the error amplifier and forces the loop to maximum duty cycle,  $>91\%$ .

## APPLICATIONS INFORMATION

Similarly, the MAX comparator forces the output to 0% duty cycle if the feedback signal is greater than 40mV above the internal reference. To prevent these two comparators from triggering due to noise, the MIN and MAX comparators' response times are deliberately delayed by two to three microseconds. These two comparators help prevent extreme output perturbations with fast output load current transients, while allowing the main feedback loop to be optimally compensated for stability.

### Thermal Shutdown

The LTC3830/LTC3830-1 have a thermal protection circuit that disables both gate drivers if activated. If the chip junction temperature reaches 150°C, both G1 and G2 are pulled low. G1 and G2 remain low until the junction temperature drops below 125°C, after which, the chip resumes normal operation.

### Soft-Start and Current Limit

The 16-lead LTC3830 devices include a soft-start circuit that is used for start-up and current limit operation. The LTC3830-1 only has the soft-start function; the current limit function is disabled. The 8-lead LTC3830 has both the soft-start and current limit function disabled. The SS pin requires an external capacitor,  $C_{SS}$ , to GND with the value determined by the required soft-start time. An internal 12 $\mu$ A current source is included to charge  $C_{SS}$ . During power-up, the COMP pin is clamped to a diode drop (B-E junction of QSS in the Block Diagram) above the voltage at the SS pin. This prevents the error amplifier from forcing the loop to maximum duty cycle. The LTC3830/LTC3830-1 operate at low duty cycle as the SS pin rises above 0.6V ( $V_{COMP} \approx 1.2V$ ). As SS continues to rise, QSS turns off and the error amplifier takes over to regulate the output. The MIN comparator is disabled during soft-start to prevent it from overriding the soft-start function.

The 16-lead LTC3830 devices include yet another feedback loop to control operation in current limit. Just before every falling edge of G1, the current comparator, CC, samples and holds the voltage drop measured across the external upper MOSFET, Q1, at the  $I_{FB}$  pin. CC compares

the voltage at  $I_{FB}$  to the voltage at the  $I_{MAX}$  pin. As the peak current rises, the measured voltage across Q1 increases due to the drop across the  $R_{DS(ON)}$  of Q1. When the voltage at  $I_{FB}$  drops below  $I_{MAX}$ , indicating that Q1's drain current has exceeded the maximum level, CC starts to pull current out of  $C_{SS}$ , cutting the duty cycle and controlling the output current level. The CC comparator pulls current out of the SS pin in proportion to the voltage difference between  $I_{FB}$  and  $I_{MAX}$ . Under minor overload conditions, the SS pin falls gradually, creating a time delay before current limit takes effect. Very short, mild overloads may not affect the output voltage at all. More significant overload conditions allow the SS pin to reach a steady state, and the output remains at a reduced voltage until the overload is removed. Serious overloads generate a large overdrive at CC, allowing it to pull SS down quickly and preventing damage to the output components. By using the  $R_{DS(ON)}$  of Q1 to measure the output current, the current limiting circuit eliminates an expensive discrete sense resistor that would otherwise be required. This helps minimize the number of components in the high current path.

The current limit threshold can be set by connecting an external resistor  $R_{IMAX}$  from the  $I_{MAX}$  pin to the main  $V_{IN}$  supply at the drain of Q1. The value of  $R_{IMAX}$  is determined by:

$$R_{IMAX} = (I_{LMAX})(R_{DS(ON)Q1})/I_{IMAX}$$

where:

$$I_{LMAX} = I_{LOAD} + (I_{RIPPLE}/2)$$

$$I_{LOAD} = \text{Maximum load current}$$

$$I_{RIPPLE} = \text{Inductor ripple current}$$

$$= \frac{(V_{IN} - V_{OUT})(V_{OUT})}{(f_{OSC})(L_O)(V_{IN})}$$

$$f_{OSC} = \text{LTC3830 oscillator frequency} = 200\text{kHz}$$

$$L_O = \text{Inductor value}$$

$$R_{DS(ON)Q1} = \text{On-resistance of Q1 at } I_{LMAX}$$

$$I_{IMAX} = \text{Internal } 12\mu\text{A sink current at } I_{MAX}$$

## APPLICATIONS INFORMATION

The  $R_{DS(ON)}$  of Q1 usually increases with temperature. To keep the current limit threshold constant, the internal  $12\mu\text{A}$  sink current at  $I_{MAX}$  is designed with a positive temperature coefficient to provide first order correction for the temperature coefficient of  $R_{DS(ON)Q1}$ .

In order for the current limit circuit to operate properly and to obtain a reasonably accurate current limit threshold, the  $I_{MAX}$  and  $I_{FB}$  pins must be Kelvin sensed at Q1's drain and source pins. In addition, connect a  $0.1\mu\text{F}$  decoupling capacitor across  $R_{I_{MAX}}$  to filter switching noise. Otherwise, noise spikes or ringing at Q1's source can cause the actual current limit to be greater than the desired current limit set point. Due to switching noise and variation of  $R_{DS(ON)}$ , the actual current limit trip point is not highly accurate. The current limiting circuitry is primarily meant to prevent damage to the power supply circuitry during fault conditions. The exact current level where the limiting circuit begins to take effect will vary from unit to unit as the  $R_{DS(ON)}$  of Q1 varies. Typically,  $R_{DS(ON)}$  varies as much as  $\pm 40\%$  and with  $\pm 25\%$  variation on the LTC3830's  $I_{MAX}$  current, this can give a  $\pm 65\%$  variation on the current limit threshold.

The  $R_{DS(ON)}$  is high if the  $V_{GS}$  applied to the MOSFET is low. This occurs during power up, when  $PV_{CC1}$  is ramping up. To prevent the high  $R_{DS(ON)}$  from activating the current limit, the LTC3830 disables the current limit circuit if  $PV_{CC1}$  is less than  $2.5\text{V}$  above  $V_{CC}$ . To ensure proper

operation of the current limit circuit,  $PV_{CC1}$  must be at least  $2.5\text{V}$  above  $V_{CC}$  when G1 is high.  $PV_{CC1}$  can go low when G1 is low, allowing the use of an external charge pump to power  $PV_{CC1}$ .

### Oscillator Frequency

The LTC3830 includes an onboard current controlled oscillator that typically free-runs at  $200\text{kHz}$ . The oscillator frequency can be adjusted by forcing current into or out of the  $FREQSET$  pin. With the pin floating, the oscillator runs at about  $200\text{kHz}$ . Every additional  $1\mu\text{A}$  of current into/out of the  $FREQSET$  pin decreases/increases the frequency by  $10\text{kHz}$ . The pin is internally servoed to  $1.265\text{V}$ , connecting a  $50\text{k}$  resistor from  $FREQSET$  to ground forces  $25\mu\text{A}$  out of the pin, causing the internal oscillator to run at approximately  $450\text{kHz}$ . Forcing an external  $10\mu\text{A}$  current into  $FREQSET$  cuts the internal frequency to  $100\text{kHz}$ . An internal clamp prevents the oscillator from running slower than about  $50\text{kHz}$ . Tying  $FREQSET$  to  $V_{CC}$  forces the chip to run at this minimum speed. The LTC3830-1 and the 8-lead LTC3830 do not have this frequency adjustment function.

### Shutdown

The LTC3830 includes a low power shutdown mode, controlled by the logic at the  $\overline{\text{SHDN}}$  pin. A high at  $\overline{\text{SHDN}}$  allows the part to operate normally. A low level at  $\overline{\text{SHDN}}$  for more than  $100\mu\text{s}$  forces the LTC3830 into shutdown mode. In this mode, all internal switching stops, the  $\text{COMP}$  and  $\text{SS}$  pins pull to ground and Q1 and Q2 turn off. The LTC3830 supply current drops to  $<10\mu\text{A}$ , although off-state leakage in the external MOSFETs may cause the total  $V_{IN}$  current to be some what higher, especially at elevated temperatures. If  $\overline{\text{SHDN}}$  returns high, the LTC3830 reruns a soft-start cycle and resumes normal operation. The LTC3830-1 does not have this shutdown function.

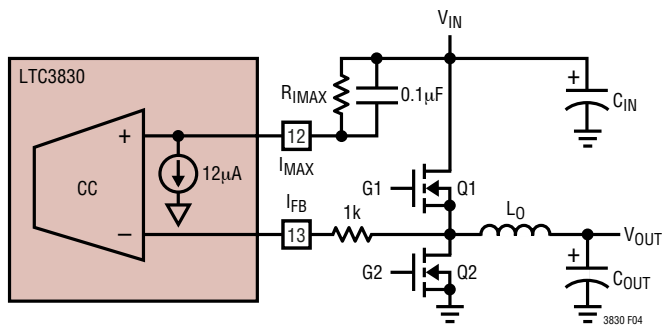

Figure 4. Current Limit Setting

## APPLICATIONS INFORMATION

### External Clock Synchronization

The LTC3830  $\overline{\text{SHDN}}$  pin doubles as an external clock input for applications that require a synchronized clock. An internal circuit forces the LTC3830 into external synchronization mode if a negative transition at the  $\overline{\text{SHDN}}$  pin is detected. In this mode, every negative transition on the  $\overline{\text{SHDN}}$  pin resets the internal oscillator and pulls the ramp signal low, this forces the LTC3830 internal oscillator to lock to the external clock frequency. The LTC3830-1 does not have this external synchronization function.

The LTC3830 internal oscillator can be externally synchronized from 100kHz to 500kHz. Frequencies above 300kHz can cause a decrease in the maximum obtainable duty cycle as rise/fall time and propagation delay take up a larger percentage of the switch cycle. Circuits using these frequencies should be checked carefully in applications where operation near dropout is important—like 3.3V to

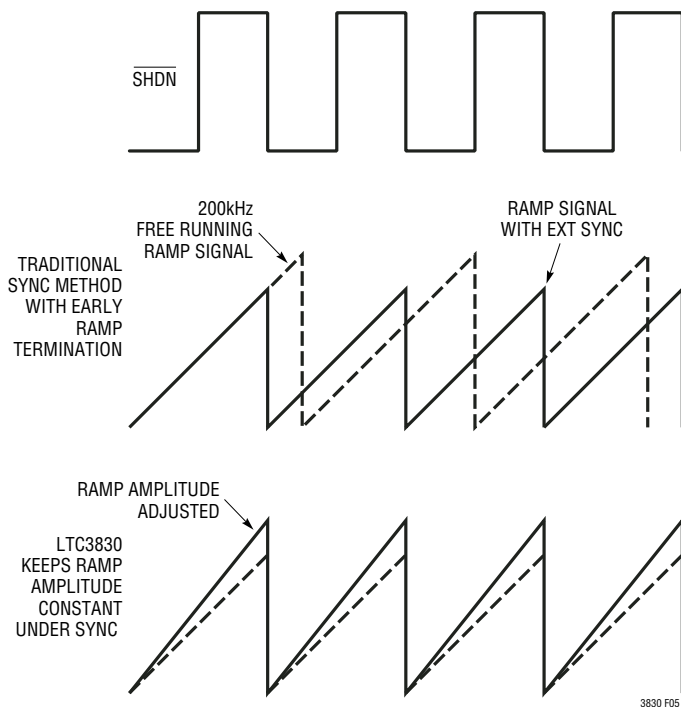

Figure 5. External Synchronization Operation

2.5V converters. The low period of this clock signal must not be  $>100\mu\text{s}$ , or else the LTC3830 enters shutdown mode.

Figure 5 describes the operation of the external synchronization function. A negative transition at the  $\overline{\text{SHDN}}$  pin forces the internal ramp signal low to restart a new PWM cycle. Notice that with the traditional sync method, the ramp amplitude is lowered as the external clock frequency goes higher. The effect of this decrease in ramp amplitude increases the open-loop gain of the controller feedback loop. As a result, the loop crossover frequency increases and it may cause the feedback loop to be unstable if the phase margin is insufficient.

To overcome this problem, the LTC3830 monitors the peak voltage of the ramp signal and adjusts the oscillator charging current to maintain a constant ramp peak.

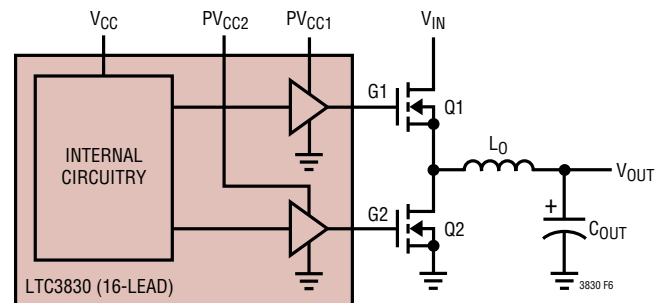

Figure 6. 16-Lead Power Supplies

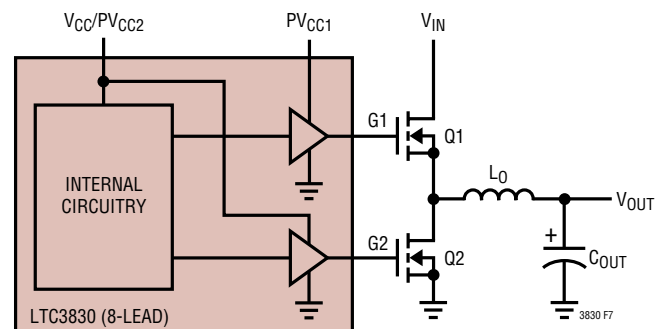

Figure 7. 8-Lead Power Supplies



## APPLICATIONS INFORMATION

The LTC3830/LTC3830-1 overcomes this problem by sensing the  $PV_{CC1}$  voltage when G1 is high. If  $PV_{CC1}$  is less than  $(V_{CC} + 2.5V)$ , the maximum G1 duty cycle is reduced to 70% by clamping the COMP pin at 1.8V (QC in BLOCK DIAGRAM). This increases the G2 on time and allows the charge pump capacitor to be refreshed.

For Applications using an external supply to power  $PV_{CC1}$ , this supply must also be higher than  $V_{CC}$  by at least 2.5V to insure normal operation.

For applications with a 5V or higher  $V_{IN}$  supply,  $PV_{CC2}$  can be tied to  $V_{IN}$  if a logic level MOSFET is used.  $PV_{CC1}$  can be supplied using a doubling charge pump as shown in Figure 9. This circuit provides  $2V_{IN} - V_F$  to  $PV_{CC1}$  while Q1 is ON. Figure 12 shows a typical 5V to 3.3V application using a doubling charge pump to generate  $PV_{CC1}$ .

### Power MOSFETs

Two N-channel power MOSFETs are required for most LTC3830 circuits. These should be selected based primarily on threshold voltage and on-resistance considerations. Thermal dissipation is often a secondary concern in high efficiency designs. The required MOSFET threshold should be determined based on the available power supply voltages and/or the complexity of the gate drive charge pump scheme. In 3.3V input designs where

an auxiliary 12V supply is available to power  $PV_{CC1}$  and  $PV_{CC2}$ , standard MOSFETs with  $R_{DS(ON)}$  specified at  $V_{GS} = 5V$  or 6V can be used with good results. The current drawn from this supply varies with the MOSFETs used and the LTC3830's operating frequency, but is generally less than 50mA.

LTC3830 applications that use 5V or lower  $V_{IN}$  voltage and a doubling/tripling charge pump to generate  $PV_{CC1}$  and  $PV_{CC2}$ , do not provide enough gate drive voltage to fully enhance standard power MOSFETs. Under this condition, the effective MOSFET  $R_{DS(ON)}$  may be quite high, raising the dissipation in the FETs and reducing efficiency. Logic level FETs are the recommended choice for 5V or lower voltage systems. Logic level FETs can be fully enhanced with a doubler/tripling charge pump and will operate at maximum efficiency.

After the MOSFET threshold voltage is selected, choose the  $R_{DS(ON)}$  based on the input voltage, the output voltage, allowable power dissipation and maximum output current. In a typical LTC3830 circuit, operating in continuous mode, the average inductor current is equal to the output load current. This current flows through either Q1 or Q2 with the power dissipation split up according to the duty cycle:

$$DC(Q1) = \frac{V_{OUT}}{V_{IN}}$$

$$DC(Q2) = 1 - \frac{V_{OUT}}{V_{IN}} = \frac{V_{IN} - V_{OUT}}{V_{IN}}$$

The  $R_{DS(ON)}$  required for a given conduction loss can now be calculated by rearranging the relation  $P = I^2R$ .

$$R_{DS(ON)Q1} = \frac{P_{MAX(Q1)}}{DC(Q1) \cdot (I_{LOAD})^2} = \frac{V_{IN} \cdot P_{MAX(Q1)}}{V_{OUT} \cdot (I_{LOAD})^2}$$

$$R_{DS(ON)Q2} = \frac{P_{MAX(Q2)}}{DC(Q2) \cdot (I_{LOAD})^2} = \frac{V_{IN} \cdot P_{MAX(Q2)}}{(V_{IN} - V_{OUT}) \cdot (I_{LOAD})^2}$$

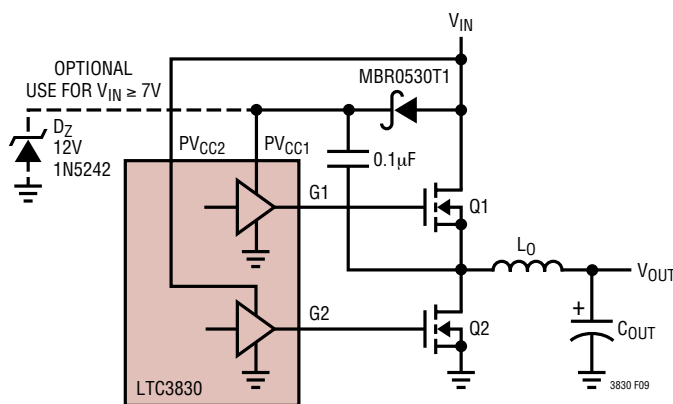

Figure 9. Doubling Charge Pump

## APPLICATIONS INFORMATION

$P_{MAX}$  should be calculated based primarily on required efficiency or allowable thermal dissipation. A typical high efficiency circuit designed for 5V input and 3.3V at 10A output might allow no more than 3% efficiency loss at full load for each MOSFET. Assuming roughly 90% efficiency at this current level, this gives a  $P_{MAX}$  value of:

$$(3.3V)(10A/0.9)(0.03) = 1.1W \text{ per FET}$$

and a required  $R_{DS(ON)}$  of:

$$R_{DS(ON)Q1} = \frac{(5V) \cdot (1.1W)}{(3.3V)(10A)^2} = 0.017\Omega$$

$$R_{DS(ON)Q2} = \frac{(5V) \cdot (1.1W)}{(5V - 3.3V)(10A)^2} = 0.032\Omega$$

Note that the required  $R_{DS(ON)}$  for Q2 is roughly twice that of Q1 in this example. This application might specify a single  $0.03\Omega$  device for Q2 and parallel two more of the same devices to form Q1. Note also that while the required  $R_{DS(ON)}$  values suggest large MOSFETs, the power dissipation numbers are only 1.1W per device or less; large TO-220 packages and heat sinks are not necessarily required in high efficiency applications. Siliconix Si4410DY

or International Rectifier IRF7413 (both in SO-8) or Siliconix SUD50N03-10 (TO-252) or ON Semiconductor MTD20N03HDL (DPAK) are small footprint surface mount devices with  $R_{DS(ON)}$  values below  $0.03\Omega$  at 5V of  $V_{GS}$  that work well in LTC3830 circuits. Using a higher  $P_{MAX}$  value in the  $R_{DS(ON)}$  calculations generally decreases the MOSFET cost and the circuit efficiency and increases the MOSFET heat sink requirements.

Table 1 highlights a variety of power MOSFETs for use in LTC3830 applications.

### Inductor Selection

The inductor is often the largest component in an LTC3830 design and must be chosen carefully. Choose the inductor value and type based on output slew rate requirements. The maximum rate of rise of inductor current is set by the inductor's value, the input-to-output voltage differential and the LTC3830's maximum duty cycle. In a typical 5V input, 3.3V output application, the maximum rise time will be:

$$\frac{DC_{MAX} \cdot (V_{IN} - V_{OUT})}{L_O} = \frac{1.615}{L_O} \frac{A}{\mu s}$$

**Table 1. Recommended MOSFETs for LTC3830 Applications**

PARTS	$R_{DS(ON)}$ AT 25°C (mΩ)	RATED CURRENT (A)	TYPICAL INPUT CAPACITANCE $C_{ISS}$ (pF)	$\theta_{JC}$ (°C/W)	$T_{JMAX}$ (°C)
Siliconix SUD50N03-10 TO-252	19	15 at 25°C 10 at 100°C	3200	1.8	175
Siliconix Si4410DY SO-8	20	10 at 25°C 8 at 70°C	2700		150
ON Semiconductor MTD20N03HDL DPAK	35	20 at 25°C 16 at 100°C	880	1.67	150
Fairchild FDS6670A SO-8	8	13 at 25°C	3200	25	150
Fairchild FDS6680 SO-8	10	11.5 at 25°C	2070	25	150
ON Semiconductor MTB75N03HDL DD PAK	9	75 at 25°C 59 at 100°C	4025	1	150
IR IRL3103S DD PAK	19	64 at 25°C 45 at 100°C	1600	1.4	175
IR IRLZ44 TO-220	28	50 at 25°C 36 at 100°C	3300	1	175
Fuji 2SK1388 TO-220	37	35 at 25°C	1750	2.08	150

Note: Please refer to the manufacturer's data sheet for testing conditions and detailed information.

## APPLICATIONS INFORMATION

where  $L_0$  is the inductor value in  $\mu\text{H}$ . With proper frequency compensation, the combination of the inductor and output capacitor values determine the transient recovery time. In general, a smaller value inductor improves transient response at the expense of ripple and inductor core saturation rating. A  $2\mu\text{H}$  inductor has a  $0.81\text{A}/\mu\text{s}$  rise time in this application, resulting in a  $6.2\mu\text{s}$  delay in responding to a  $5\text{A}$  load current step. During this  $6.2\mu\text{s}$ , the difference between the inductor current and the output current is made up by the output capacitor. This action causes a temporary voltage droop at the output. To minimize this effect, the inductor value should usually be in the  $1\mu\text{H}$  to  $5\mu\text{H}$  range for most  $5\text{V}$  input LTC3830 circuits. To optimize performance, different combinations of input and output voltages and expected loads may require different inductor values.

Once the required value is known, the inductor core type can be chosen based on peak current and efficiency requirements. Peak current in the inductor will be equal to the maximum output load current plus half of the peak-to-peak inductor ripple current. Ripple current is set by the inductor value, the input and output voltage and the operating frequency. The ripple current is approximately equal to:

$$I_{\text{RIPPLE}} = \frac{(V_{\text{IN}} - V_{\text{OUT}}) \cdot (V_{\text{OUT}})}{f_{\text{OSC}} \cdot L_0 \cdot V_{\text{IN}}}$$

$$f_{\text{OSC}} = \text{LTC3830 oscillator frequency} = 200\text{kHz}$$

$$L_0 = \text{Inductor value}$$

Solving this equation with our typical  $5\text{V}$  to  $3.3\text{V}$  application with a  $2\mu\text{H}$  inductor, we get:

$$\frac{(5\text{V} - 3.3\text{V}) \cdot 3.3\text{V}}{200\text{kHz} \cdot 2\mu\text{H} \cdot 5\text{V}} = 2.8\text{A}_{\text{P-P}}$$

Peak inductor current at  $10\text{A}$  load:

$$10\text{A} + (2.8\text{A}/2) = 11.4\text{A}$$

The ripple current should generally be between 10% and 40% of the output current. The inductor must be able to withstand this peak current without saturating, and the copper resistance in the winding should be kept as low as possible to minimize resistive power loss. Note that in circuits not employing the current limit function, the current in the inductor may rise above this maximum under short-circuit or fault conditions; the inductor should be sized accordingly to withstand this additional current. Inductors with gradual saturation characteristics are often the best choice.

### Input and Output Capacitors

A typical LTC3830 design places significant demands on both the input and the output capacitors. During normal steady load operation, a buck converter like the LTC3830 draws square waves of current from the input supply at the switching frequency. The peak current value is equal to the output load current plus  $1/2$  the peak-to-peak ripple current. Most of this current is supplied by the input bypass capacitor. The resulting RMS current flow in the input capacitor heats it and causes premature capacitor failure in extreme cases. Maximum RMS current occurs with 50% PWM duty cycle, giving an RMS current value equal to  $I_{\text{OUT}}/2$ . A low ESR input capacitor with an adequate ripple current rating must be used to ensure reliable operation. Note that capacitor manufacturers' ripple current ratings are often based on only 2000 hours (3 months) lifetime at rated temperature. Further derating of the input capacitor ripple current beyond the manufacturer's specification is recommended to extend the useful life of the circuit. Lower operating temperature has the largest effect on capacitor longevity.

## APPLICATIONS INFORMATION

The output capacitor in a buck converter under steady-state conditions sees much less ripple current than the input capacitor. Peak-to-peak current is equal to inductor ripple current, usually 10% to 40% of the total load current. Output capacitor duty places a premium not on power dissipation but on ESR. During an output load transient, the output capacitor must supply all of the additional load current demanded by the load until the LTC3830 adjusts the inductor current to the new value. ESR in the output capacitor results in a step in the output voltage equal to the ESR value multiplied by the change in load current. An 5A load step with a 0.05Ω ESR output capacitor results in a 250mV output voltage shift; this is 7.6% of the output voltage for a 3.3V supply! Because of the strong relationship between output capacitor ESR and output load transient response, choose the output capacitor for ESR, not for capacitance value. A capacitor with suitable ESR will usually have a larger capacitance value than is needed to control steady-state output ripple.

Electrolytic capacitors rated for use in switching power supplies with specified ripple current ratings and ESR can be used effectively in LTC3830 applications. OS-CON electrolytic capacitors from Sanyo and other manufacturers give excellent performance and have a very high performance/size ratio for electrolytic capacitors. Surface mount applications can use either electrolytic or dry tantalum capacitors. Tantalum capacitors must be surge tested and specified for use in switching power supplies. Low cost, generic tantalums are known to have very short lives followed by explosive deaths in switching power supply applications. Other capacitors that can be used include the Sanyo POSCAP and MV-WX series.

A common way to lower ESR and raise ripple current capability is to parallel several capacitors. A typical LTC3830 application might exhibit 5A input ripple current. Sanyo OS-CON capacitors, part number 10SA220M (220μF/10V), feature 2.3A allowable ripple current at 85°C; three in parallel at the input (to withstand the input ripple current) meet the above requirements. Similarly, Sanyo POSCAP 4TPB470M (470μF/4V) capacitors have

a maximum rated ESR of 0.04Ω; three in parallel lower the net output capacitor ESR to 0.013Ω.

### Feedback Loop Compensation

The LTC3830 voltage feedback loop is compensated at the COMP pin, which is the output node of the error amplifier. The feedback loop is generally compensated with an RC + C network from COMP to GND as shown in Figure 10a.

Loop stability is affected by the values of the inductor, the output capacitor, the output capacitor ESR, the error amplifier transconductance and the error amplifier compensation network. The inductor and the output capacitor create a double pole at the frequency:

$$f_{LC} = 1/[2\pi\sqrt{(L_O)(C_{OUT})}]$$

The ESR of the output capacitor and the output capacitor value form a zero at the frequency:

$$f_{ESR} = 1/[2\pi(ESR)(C_{OUT})]$$

The compensation network used with the error amplifier must provide enough phase margin at the 0dB crossover frequency for the overall open-loop transfer function. The zero and pole from the compensation network are:

$$f_z = 1/[2\pi(R_C)(C_C)] \text{ and}$$

$$f_p = 1/[2\pi(R_C)(C_1)] \text{ respectively}$$

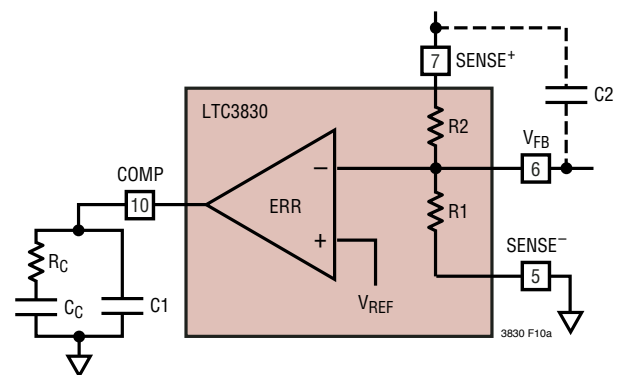

Figure 10a. Compensation Pin Hook-Up

## APPLICATIONS INFORMATION

Figure 10b shows the Bode plot of the overall transfer function.

When low ESR output capacitors (Sanyo OS-CON) are used, the ESR zero can be high enough in frequency that it provides little phase boost at the loop crossover frequency. As a result, the phase margin becomes inadequate and the load transient is not optimized. To resolve this problem, a small capacitor can be connected between the top of the resistor divider network and the  $V_{FB}$  pin to create a pole-zero pair in the loop compensation. The zero location is prior to the pole location and thus, phase lead can be added to boost the phase margin at the loop crossover frequency. The pole and zero locations are located at:

$$f_{zC2} = 1/[2\pi(R2)(C2)] \text{ and}$$

$$f_{pC2} = 1/[2\pi(R1||R2)(C2)]$$

where  $R1||R2$  is the parallel combination resistance of  $R1$  and  $R2$ . Choose  $C2$  so that the zero is located at a lower frequency compared to  $f_{CO}$  and the pole location is high enough that the closed loop has enough phase margin for stability. Figure 10c shows the Bode plot using phase lead compensation around the LTC3830 resistor divider network. Note: This technique is effective only when  $R1 \gg R2$  i.e., at high output voltages only so that the pole and zero are sufficiently separated.

Although a mathematical approach to frequency compensation can be used, the added complication of input and/or output filters, unknown capacitor ESR, and gross operating point changes with input voltage, load current variations, all suggest a more practical empirical method. This can be done by injecting a transient current at the load and using an RC network box to iterate toward the final values, or by obtaining the optimum loop response using a network analyzer to find the actual loop poles and zeros.

Table 2 shows the suggested compensation component value for 5V to 3.3V applications based on Sanyo OS-CON 4SP820M low ESR output capacitors.

**Table 2. Recommended Compensation Network for 5V to 3.3V Applications Using Multiple Paralleled 820 $\mu$ F Sanyo OS-CON 4SP820M Output Capacitors**

L1 ( $\mu$ H)	C <sub>OUT</sub> ( $\mu$ F)	R <sub>C</sub> (k $\Omega$ )	C <sub>C</sub> (nF)	C1 (pF)	C2 (pF)
1.2	1640	6.2	3.3	470	1000
1.2	2460	12	3.3	470	1000
1.2	4100	12	1.8	220	1000
2.4	1640	15	2.7	330	1000
2.4	2460	20	1.0	220	1000
2.4	4100	36	1.0	220	1000
4.7	1640	30	1.8	330	1000
4.7	2460	36	1.0	180	1000
4.7	4100	82	1.0	180	1000

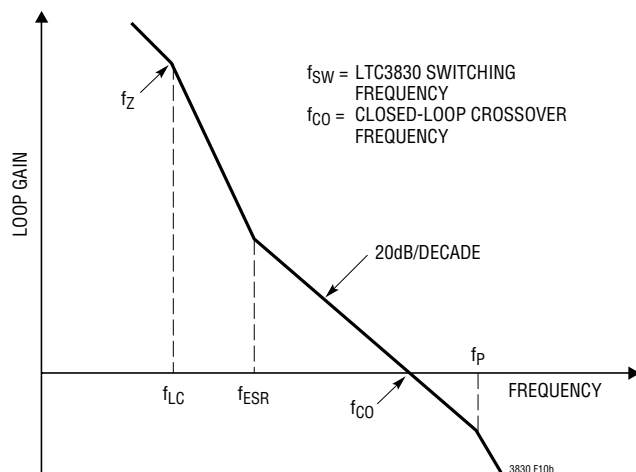

Figure 10b. Bode Plot of the LTC3830 Overall Transfer Function

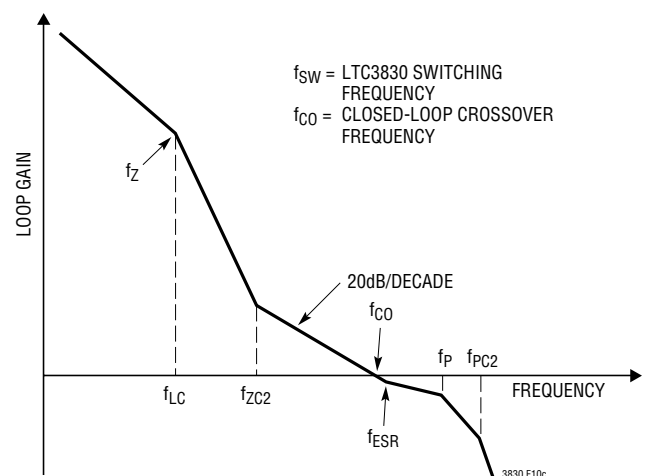

Figure 10c. Bode Plot of the LTC3830 Overall Transfer Function Using a Low ESR Output Capacitor

## APPLICATIONS INFORMATION

Table 3 shows the suggested compensation component values for 5V to 3.3V applications based on 470 $\mu$ F Sanyo POSCAP 4TPB470M output capacitors.

**Table 3. Recommended Compensation Network for 5V to 3.3V Applications Using Multiple Paralleled 470 $\mu$ F Sanyo POSCAP 4TPB470M Output Capacitors**

L1 ( $\mu$ H)	C <sub>OUT</sub> ( $\mu$ F)	R <sub>C</sub> (k $\Omega$ )	C <sub>C</sub> (nF)	C1 (pF)
1.2	1410	6.8	4.7	33
1.2	2820	15	2.2	33
1.2	4700	22	2.2	33
2.4	1410	18	10	33
2.4	2820	43	2.2	33
2.4	4700	62	2.2	10
4.7	1410	43	10	10
4.7	2820	91	33	10
4.7	4700	150	10	10

Table 4 shows the suggested compensation component values for 5V to 3.3V applications based on 1500 $\mu$ F Sanyo MV-WX output capacitors.

**Table 4. Recommended Compensation Network for 5V to 3.3V Applications Using Multiple Paralleled 1500 $\mu$ F Sanyo MV-WX Output Capacitors**

L1 ( $\mu$ H)	C <sub>OUT</sub> ( $\mu$ F)	R <sub>C</sub> (k $\Omega$ )	C <sub>C</sub> (nF)	C1 (pF)
1.2	4500	22	1.5	120
1.2	6000	30	1	82
1.2	9000	39	0.47	56
2.4	4500	51	1	56
2.4	6000	62	1	33
2.4	9000	82	0.47	27
4.7	4500	100	3.3	15
4.7	6000	150	0.47	15
4.7	9000	200	0.47	15

## LAYOUT CONSIDERATIONS

When laying out the printed circuit board, use the following checklist to ensure proper operation of the LTC3830. These items are also illustrated graphically in the layout diagram of Figure 11. The thicker lines show the high current paths. Note that at 10A current levels or above, current density in the PC board itself is a serious concern. Traces carrying high current should be as wide as possible. For example, a PCB fabricated with 2oz copper requires a minimum trace width of 0.15" to carry 10A.

1. In general, layout should begin with the location of the power devices. Be sure to orient the power circuitry so that a clean power flow path is achieved. Conductor widths should be maximized and lengths minimized. After you are satisfied with the power path, the control circuitry should be laid out. It is much easier to find routes for the relatively small traces in the control circuits than it is to find circuitous routes for high current paths.

2. The GND and PGND pins should be shorted directly at the LTC3830. This helps to minimize internal ground disturbances in the LTC3830 and prevent differences in ground potential from disrupting internal circuit operation. This connection should then tie into the ground plane at a single point, preferably at a fairly quiet point in the circuit such as close to the output capacitors. This is not always practical, however, due to physical constraints. Another reasonably good point to make this connection is between the output capacitors and the source connection of the bottom MOSFET Q2. Do not tie this single point ground in the trace run between the Q2 source and the input capacitor ground, as this area of the ground plane will be very noisy.

## APPLICATIONS INFORMATION

3. The small-signal resistors and capacitors for frequency compensation and soft-start should be located very close to their respective pins and the ground ends connected to the signal ground pin through a separate trace. Do not connect these parts to the ground plane!

4. The  $V_{CC}$ ,  $PV_{CC1}$  and  $PV_{CC2}$  decoupling capacitors should be as close to the LTC3830 as possible. The  $4.7\mu\text{F}$  and  $1\mu\text{F}$  bypass capacitors shown at  $V_{CC}$ ,  $PV_{CC1}$  and  $PV_{CC2}$  will help provide optimum regulation performance.

5. The (+) plate of  $C_{IN}$  should be connected as close as possible to the drain of the upper MOSFET, Q1. An additional  $1\mu\text{F}$  ceramic capacitor between  $V_{IN}$  and power ground is recommended.

6. The  $SENSE$  and  $V_{FB}$  pins are very sensitive to pickup from the switching node. Care should be taken to isolate  $SENSE$  and  $V_{FB}$  from possible capacitive coupling to the inductor switching signal. Connecting the  $SENSE^+$  and  $SENSE^-$  close to the load can significantly improve load regulation.

7. Kelvin sense  $I_{MAX}$  and  $I_{FB}$  at Q1's drain and source pins.

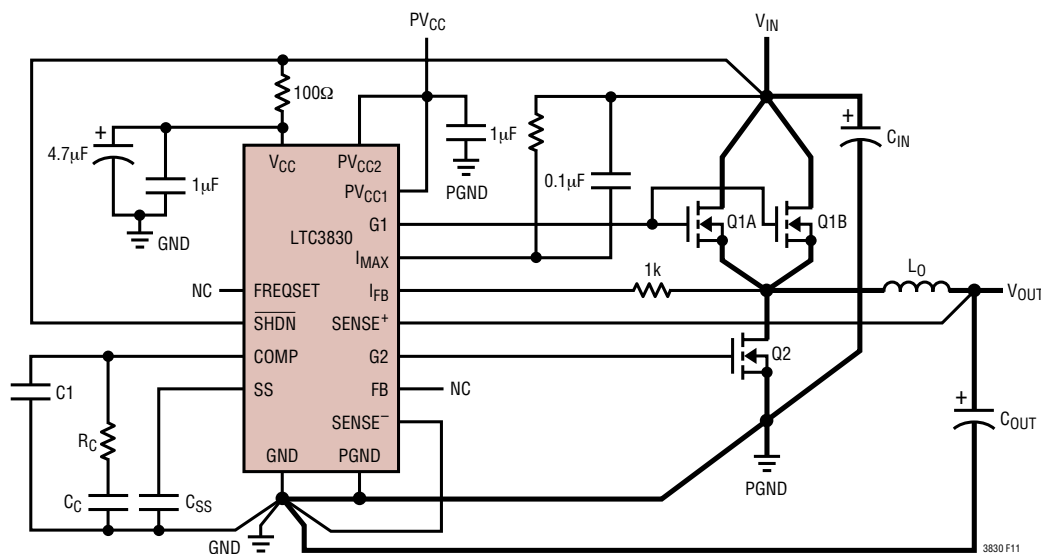

Figure 11. Typical Schematic Showing Layout Considerations

APPLICATIONS INFORMATION

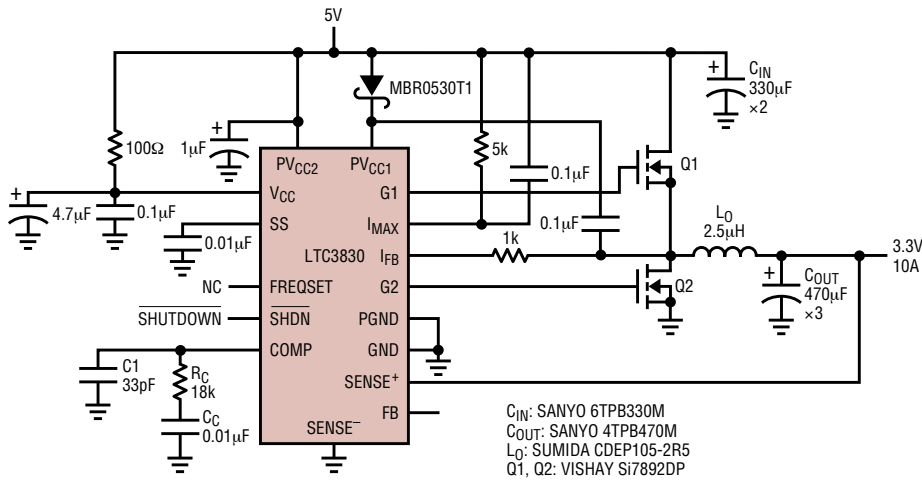
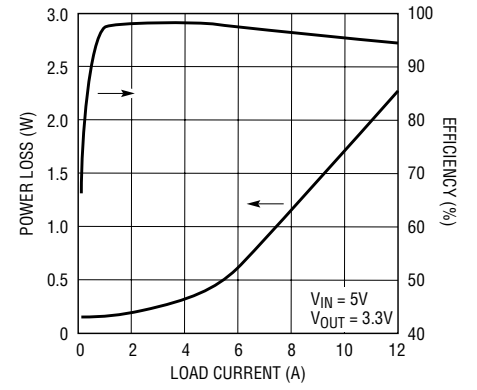

Figure 12. 5V to 3.3V, 10A Application



3830 F012

# PACKAGE DESCRIPTION

## GN Package 16-Lead Plastic SSOP (Narrow .150 Inch) (Reference LTC DWG # 05-08-1641)

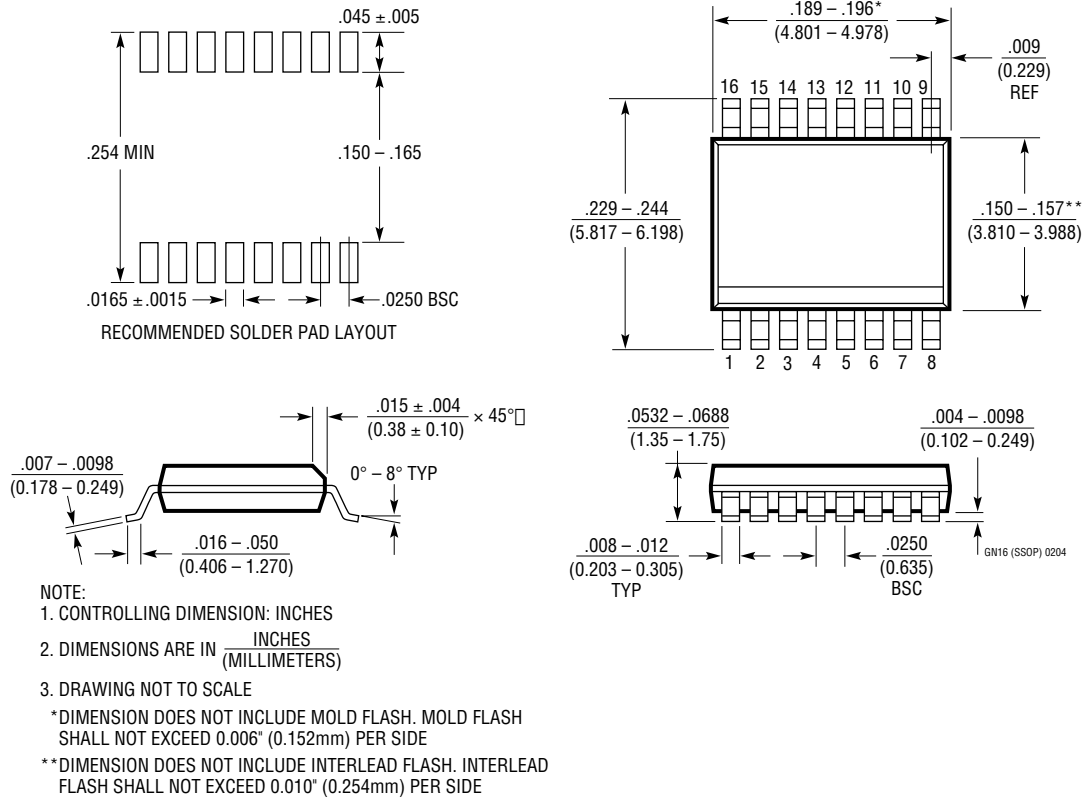

# PACKAGE DESCRIPTION

**S8 Package**  
**8-Lead Plastic Small Outline (Narrow .150 Inch)**  
 (Reference LTC DWG # 05-08-1610)

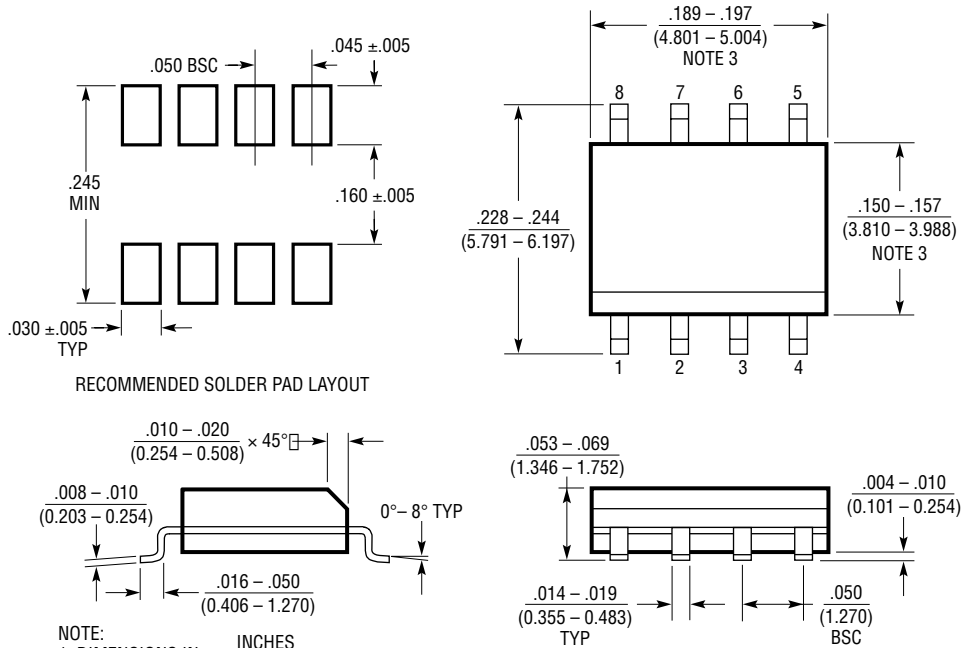

- NOTE:  
 1. DIMENSIONS IN  $\frac{\text{INCHES}}{\text{MILLIMETERS}}$   
 2. DRAWING NOT TO SCALE  
 3. THESE DIMENSIONS DO NOT INCLUDE MOLD FLASH OR PROTRUSIONS.  
 MOLD FLASH OR PROTRUSIONS SHALL NOT EXCEED  $.006''$  (0.15mm)

S08 0303

# PACKAGE DESCRIPTION

## S Package 16-Lead Plastic Small Outline (Narrow .150 Inch) (Reference LTC DWG # 05-08-1610)

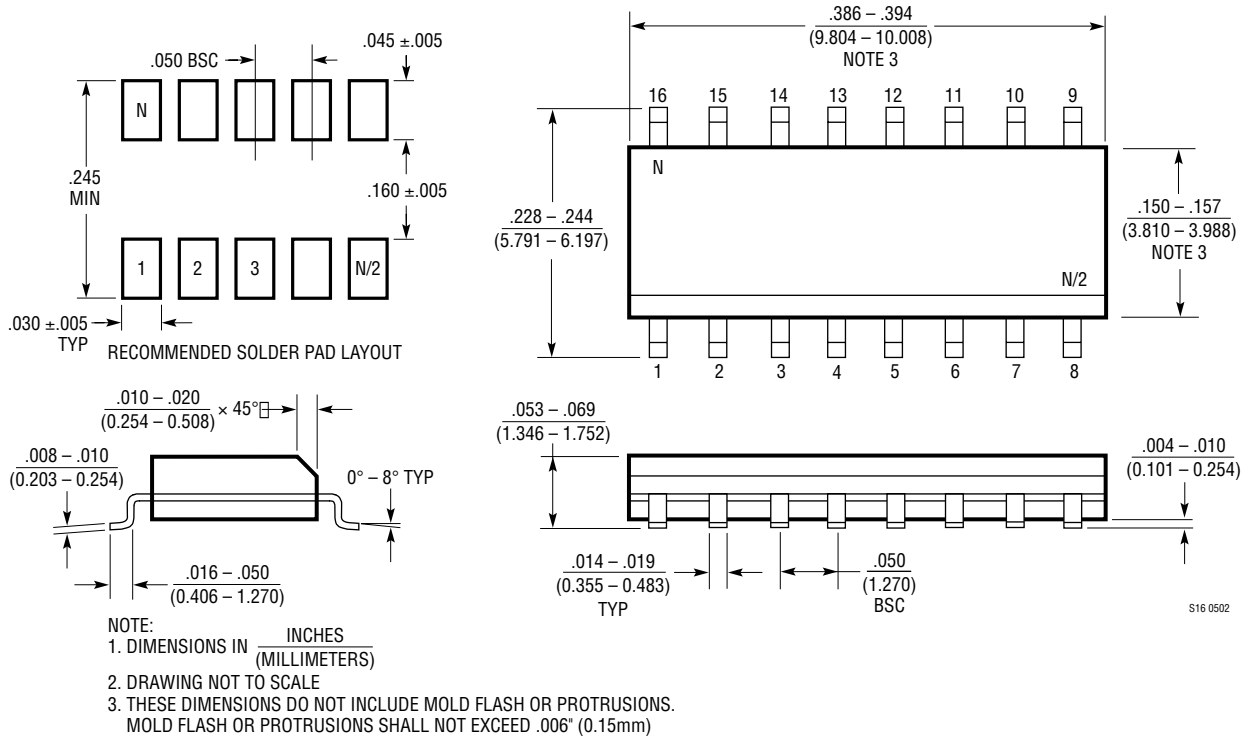

## TYPICAL APPLICATION

Typical 3.3V to 2.5V, 14A Application

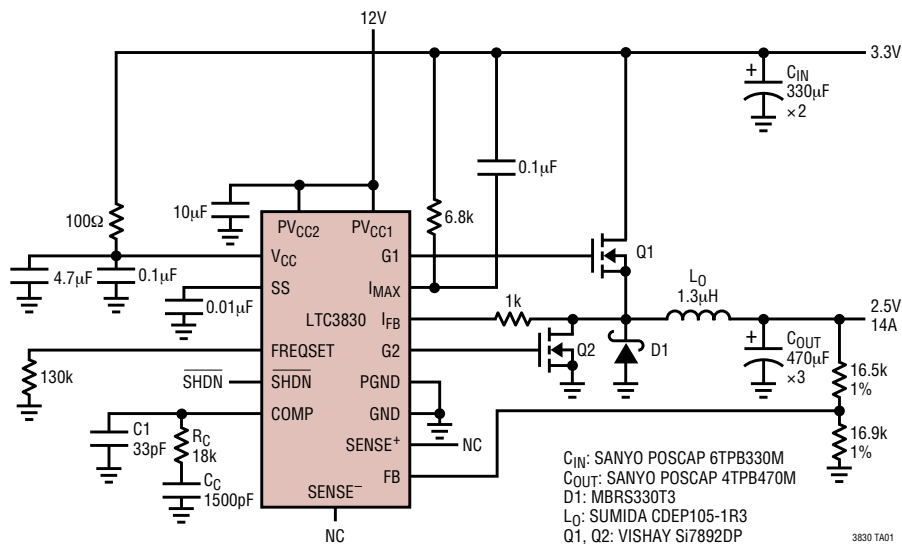

## RELATED PARTS

PART NUMBER	DESCRIPTION	COMMENTS
LTC1530	High Power Synchronous Switching Regulator Controller	SO-8 with Current Limit. No R <sub>SENSE</sub> <sup>TM</sup> Required
LTC1628/LTC3728	Dual High Efficiency 2-Phase Synchronous Step-Down Controller	Constant Frequency, Standby 5V and 3.3V LDOs, 3.5V ≤ V <sub>IN</sub> ≤ 36V
LTC1702	Dual High Efficiency 2-Phase Synchronous Step-Down Controller	550kHz, 25MHz GBW Voltage Mode, V <sub>IN</sub> ≤ 7V, No R <sub>SENSE</sub>
LTC1709	2-Phase, 5-Bit Desktop VID Synchronous Step-Down Controller	Current Mode, V <sub>IN</sub> to 36V, I <sub>OUT</sub> Up to 42A
LTC1736	Synchronous Step-Down Controller with 5-Bit Mobile VID Control	Fault Protection, Power Good, 3.5V to 36V Input, Current Mode
LTC1773	Synchronous Step-Down Controller in MS10	Up to 95% Efficiency, 550kHz, 2.65V ≤ V <sub>IN</sub> ≤ 8.5V, 0.8V ≤ V <sub>OUT</sub> ≤ V <sub>IN</sub> , Synchronizable to 750kHz
LTC1778	Wide Operating Range/Step-Down Controller, No R <sub>SENSE</sub>	V <sub>IN</sub> Up to 36V, Current Mode, Power Good
LTC1873	Dual Synchronous Switching Regulator with 5-Bit Desktop VID	1.3V to 3.5V Programmable Core Output Plus I/O Output
LTC1876	2-Phase, Dual Step-Down Synchronous Controller with Integrated Step-Up DC/DC Regulator	Step-Down DC/DC Conversion from 3V <sub>IN</sub> . Minimum C <sub>IN</sub> and C <sub>OUT</sub> , Uses Logic-Level N-Channel MOSFETs
LTC1929/LTC3729	2-Phase, Synchronous High Efficiency Converter with Mobile VID	Current Mode Ensures Accurate Current Sensing V <sub>IN</sub> Up to 36V, I <sub>OUT</sub> Up to 40A
LTC3713	Low Input Voltage, High Power, No R <sub>SENSE</sub> , Step-Down Synchronous Controller	Minimum V <sub>IN</sub> : 1.5V, Uses Standard Logic-Level N-Channel MOSFETs
LTC3770	Fast DC/DC Step-Down Synchronous Controller with Margining, Tracking and PLL	4V ≤ V <sub>IN</sub> ≤ 32V, 0.6V ≤ V <sub>OUT</sub> ≤ 28V, Powerful Gate Drivers
LTC3831	High Power Synchronous Switching Regulator Controller for DDR Memory Termination	V <sub>OUT</sub> Tracks 1/2 of V <sub>IN</sub> or External Reference
LTC3832	Synchronous Step-Down Controller	0.6V ≤ V <sub>OUT</sub> ≤ 5V, Pin-for-Pin Compatible with the LTC3830

No R<sub>SENSE</sub> is a trademark of Linear Technology Corporation.

## Looking for pricing, stock, or lifecycle information?

Click below to explore more details on WIN SOURCE:

 [View LTC3830EGN#PBF on WIN SOURCE](#)

 [Linear Technology](#) Information

## Optimize Your Supply Chain with WIN SOURCE Solutions

-  Global Sourcing Solution
-  Obsolete Management
-  Cost Control Management
-  Shortage Management
-  Alternative Solution
-  Excess Inventory Management