



**THE DATASHEET OF  
LTC3831EGN#TRPBF**



# High Power Synchronous Switching Regulator Controller for DDR Memory Termination

## FEATURES

- High Power Switching Regulator Controller for DDR Memory Termination
- $V_{OUT}$  Tracks 1/2 of  $V_{IN}$  or External  $V_{REF}$
- No Current Sense Resistor Required
- Low Input Supply Voltage Range: 3V to 8V
- Maximum Duty Cycle >91% Over Temperature
- Drives All N-Channel External MOSFETs
- High Efficiency: Over 95% Possible
- Programmable Fixed Frequency Operation: 100kHz to 500kHz
- External Clock Synchronization Operation
- Programmable Soft-Start
- Low Shutdown Current: <10 $\mu$ A
- Overtemperature Protection
- Available in 16-Pin Narrow SSOP Package

## APPLICATIONS

- DDR SDRAM Termination
- SSTL\_2 Interface
- SSTL\_3 Interface

## DESCRIPTION

The LTC<sup>®</sup>3831 is a high power, high efficiency switching regulator controller designed for DDR memory termination. The LTC3831 generates an output voltage equal to 1/2 of an external supply or reference voltage. The LTC3831 uses a synchronous switching architecture with N-channel MOSFETs. Additionally, the chip senses output current through the drain-source resistance of the upper N-channel FET, providing an adjustable current limit without a current sense resistor.

The LTC3831 operates with input supply voltage as low as 3V and with a maximum duty cycle of >91%. It includes a fixed frequency PWM oscillator for low output ripple operation. The 200kHz free-running clock frequency can be externally adjusted or synchronized with an external signal from 100kHz to above 500kHz. In shutdown mode, the LTC3831 supply current drops to <10 $\mu$ A.

LT, LT, LTC and LTM are registered trademarks of Linear Technology Corporation. All other trademarks are the property of their respective owners.

## TYPICAL APPLICATION

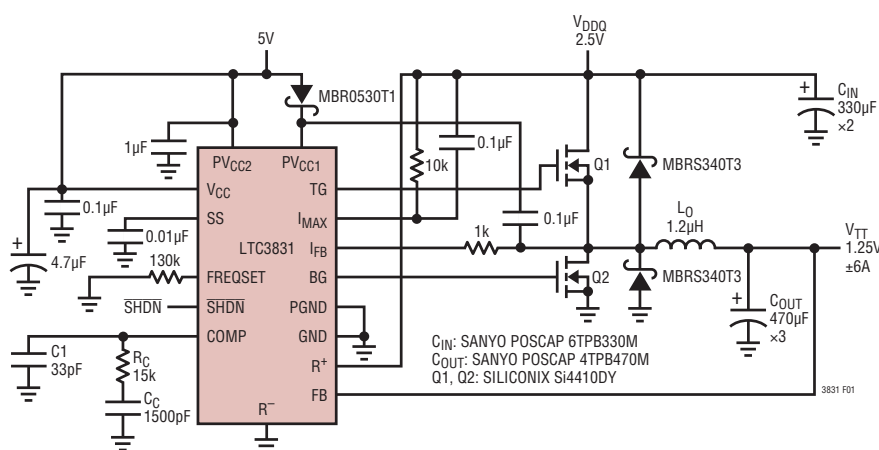
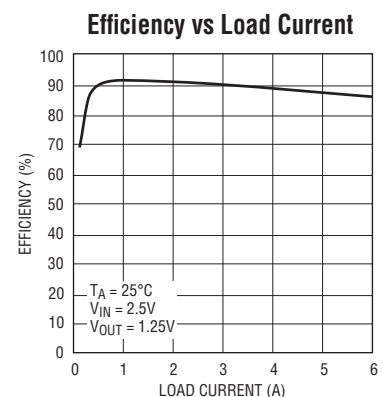

Figure 1. Typical DDR Memory Termination Application



2831 G01

## ABSOLUTE MAXIMUM RATINGS

(Note 1)

Supply Voltage

$V_{CC}$  ..... 9V

$PV_{CC1,2}$  ..... 14V

Input Voltage

$I_{FB}$ ,  $I_{MAX}$  ..... -0.3V to 14V

$R^+$ ,  $R^-$ ,  $FB$ ,  $\overline{SHDN}$ ,  $FREQSET$  ..... -0.3V to  $V_{CC}$  to 0.3V

Junction Temperature (Note 9) ..... 125°C

Operating Temperature Range Note 4) ..... -40°C to 85°C

Storage Temperature Range ..... -65°C to 150°C

Lead Temperature (Soldering, 10 sec) ..... 300°C

## PIN CONFIGURATION

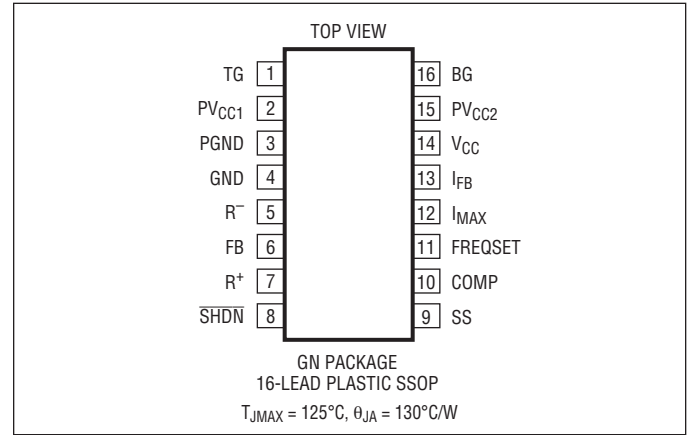

## ORDER INFORMATION

LEAD FREE FINISH	TAPE AND REEL	PART MARKING	PACKAGE DESCRIPTION	TEMPERATURE RANGE
LTC3831EGN#PBF	LTC3831EGN#TRPBF	3831	16-Lead Plastic SSOP	-40°C to 85°C
LTC3831IGN#PBF	LTC3831IGN#TRPBF	3831	16-Lead Plastic SSOP	-40°C to 85°C
LEAD BASED FINISH	TAPE AND REEL	PART MARKING	PACKAGE DESCRIPTION	TEMPERATURE RANGE
LTC3831EGN	LTC3831EGN#TR	3831	16-Lead Plastic SSOP	-40°C to 85°C
LTC3831IGN	LTC3831IGN#TR	3831	16-Lead Plastic SSOP	-40°C to 85°C

Consult LTC Marketing for parts specified with wider operating temperature ranges.

For more information on lead free part marking, go to: <http://www.linear.com/leadfree/>

For more information on tape and reel specifications, go to: <http://www.linear.com/tapeandreel/>

## ELECTRICAL CHARACTERISTICS

The ● denotes specifications that apply over the full operating temperature range, otherwise specifications are at  $T_A = 25^\circ\text{C}$ .  $V_{CC}$ ,  $PV_{CC1}$ ,  $PV_{CC2} = 5\text{V}$ ,  $V_{R+} = 2.5\text{V}$ ,  $V_{R-} = \text{GND}$ , unless otherwise noted. (Note 2)

SYMBOL	PARAMETER	CONDITIONS	MIN	TYP	MAX	UNITS
$V_{CC}$	Supply Voltage	●	3	5	8	V
$PV_{CC}$	$PV_{CC1}$ , $PV_{CC2}$ , Voltage	(Note 7) ●	3		13.2	V
$V_{UVLO}$	Undervoltage Lockout Voltage			2.4	2.9	V
$V_{FB}$	Feedback Voltage	$V_{R+} = 2.5\text{V}$ , $V_{R-} = 0\text{V}$ , $V_{COMP} = 1.25\text{V}$ ●	1.231	1.25	1.269	V
$\Delta V_{OUT}$	Output Load Regulation Output Line Regulation	$I_{OUT} = 0\text{A to } 10\text{A}$ (Note 6) $V_{CC} = 4.75\text{V to } 5.25\text{V}$		2 0.1		mV mV
$I_{VCC}$	Supply Current	Figure 2, $V_{SHDN} = V_{CC}$ ● $V_{SHDN} = 0\text{V}$ ●		0.7 1	1.6 10	mA μA
$I_{PVCC}$	$PV_{CC}$ Supply Current	Figure 2, $V_{SHDN} = V_{CC}$ (Note 3) ● $V_{SHDN} = 0\text{V}$ ●		14 0.1	20 10	mA μA
$\Delta f_{OSC}$	Internal Oscillator Frequency	FREQSET Floating ●	160	200	240	kHz
$V_{SAWL}$	$V_{COMP}$ at Minimum Duty Cycle			1.2		V
$V_{SAWH}$	$V_{COMP}$ at Maximum Duty Cycle			2.2		V

## ELECTRICAL CHARACTERISTICS

The ● denotes specifications that apply over the full operating temperature range, otherwise specifications are at  $T_A = 25^\circ\text{C}$ .  $V_{CC}$ ,  $PV_{CC1}$ ,  $PV_{CC2} = 5\text{V}$ ,  $V_{R+} = 2.5\text{V}$ ,  $V_{R-} = \text{GND}$ , unless otherwise noted. (Note 2)

SYMBOL	PARAMETER	CONDITIONS	MIN	TYP	MAX	UNITS	
$V_{\text{COMP MAX}}$	Maximum $V_{\text{COMP}}$	$V_{\text{FB}} = 0\text{V}$ , $PV_{\text{CC1}} = 8\text{V}$		2.85		V	
$\Delta f_{\text{OSC}}/\Delta I_{\text{FREQSET}}$	Frequency Adjustment			10		kHz/ $\mu\text{A}$	
$A_V$	Error Amplifier Open-Loop DC Gain		●	46	55	dB	
$g_m$	Error Amplifier Transconductance		●	520	650	780	$\mu\text{mho}$
$I_{\text{COMP}}$	Error Amplifier Output Sink/Source Current			100		$\mu\text{A}$	
$I_{\text{MAX}}$	$I_{\text{MAX}}$ Sink Current	$V_{\text{IMAX}} = V_{\text{CC}}$	●	9	12	15	$\mu\text{A}$
	$I_{\text{MAX}}$ Sink Current Tempco	$V_{\text{IMAX}} = V_{\text{CC}}$ (Note 6)		4	12	20	$\mu\text{A}$
$V_{\text{IH}}$	SHDN Input High Voltage		●	2.4		V	
$V_{\text{IL}}$	SHDN Input Low Voltage		●		0.8	V	
$I_{\text{IN}}$	SHDN Input Current	$V_{\text{SHDN}} = V_{\text{CC}}$	●	0.1	1	$\mu\text{A}$	
$I_{\text{SS}}$	Soft-Start Current	$V_{\text{SS}} = 0\text{V}$ , $V_{\text{IMAX}} = 0\text{V}$ , $V_{\text{IFB}} = V_{\text{CC}}$	●	-8	-12	-16	$\mu\text{A}$
$I_{\text{SSIL}}$	Maximum Soft-Start Sink Current Undercurrent Limit	$V_{\text{IMAX}} = V_{\text{CC}}$ , $V_{\text{IFB}} = 0\text{V}$ , $V_{\text{SS}} = V_{\text{CC}}$ (Note 8), $PV_{\text{CC1}} = 8\text{V}$		1.6		mA	
$R^+$	$R^+$ Input Resistance			49.5		k $\Omega$	
$t_r$ , $t_f$	Driver Rise/Fall Time	Figure 2, $PV_{\text{CC1}} = PV_{\text{CC2}} = 5\text{V}$ (Note 5)	●	80	250	ns	
$t_{\text{NOV}}$	Driver Nonoverlap Time	Figure 2, $PV_{\text{CC1}} = PV_{\text{CC2}} = 5\text{V}$ (Note 5)	●	25	120	250	ns
$DC_{\text{MAX}}$	Maximum TG Duty Cycle	Figure 2, $V_{\text{FB}} = 0\text{V}$ (Note 5), $PV_{\text{CC1}} = 8\text{V}$	●	91	95	%	

**Note 1:** Stresses beyond those listed under Absolute Maximum Ratings may cause permanent damage to the device. Exposure to any Absolute Maximum Rating condition for extended periods may affect device reliability and lifetime.

**Note 2:** All currents into device pins are positive; all currents out of device pins are negative. All voltages are referenced to ground unless otherwise specified.

**Note 3:** Supply current in normal operation is dominated by the current needed to charge and discharge the external FET gates. This will vary with the LTC3831 operating frequency, operating voltage and the external FETs used.

**Note 4:** The LTC3831EGN is guaranteed to meet performance specifications from  $0^\circ\text{C}$  to  $85^\circ\text{C}$ . Specifications over the  $-40^\circ\text{C}$  to  $85^\circ\text{C}$  operating temperature range are assured by design, characterization and correlation with statistical process controls. The LTC 3831IGN is guaranteed to meet performance specifications over the full  $-40^\circ\text{C}$  to  $85^\circ\text{C}$  temperature range.

**Note 5:** Rise and fall times are measured using 10% and 90% levels. Duty cycle and nonoverlap times are measured using 50% levels.

**Note 6:** Guaranteed by design, not subject to test.

**Note 7:**  $PV_{\text{CC1}}$  must be higher than  $V_{\text{CC}}$  by at least 2.5V for TG to operate at 95% maximum duty cycle and for the current limit protection circuit to be active.

**Note 8:** The current limiting amplifier can sink but cannot source current. Under normal (not current limited) operation, the output current will be zero.

**Note 9:** This IC includes overtemperature protection that is intended to protect the device during momentary overload conditions. Junction temperature will exceed  $125^\circ\text{C}$  when overtemperature protection is active. Continuous operation above the specified maximum operating junction temperature may impair device reliability.

## TYPICAL PERFORMANCE CHARACTERISTICS

### Load Regulation

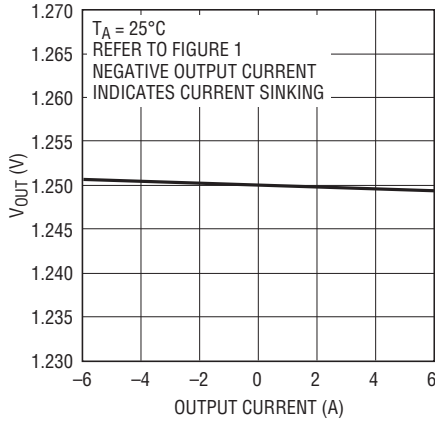

3831 G02

### Line Regulation

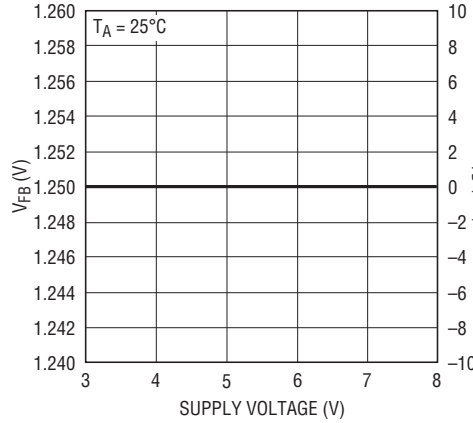

3831 G03

### Error Amplifier Transconductance vs Temperature

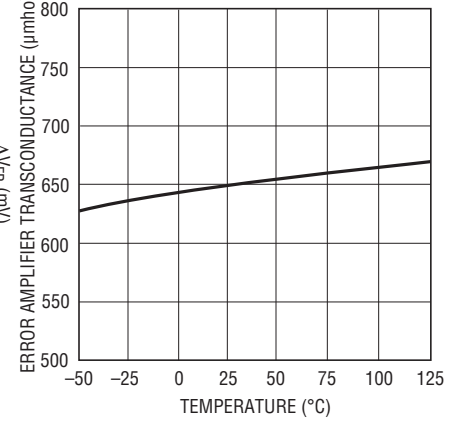

3831 G05

### Output Temperature Drift

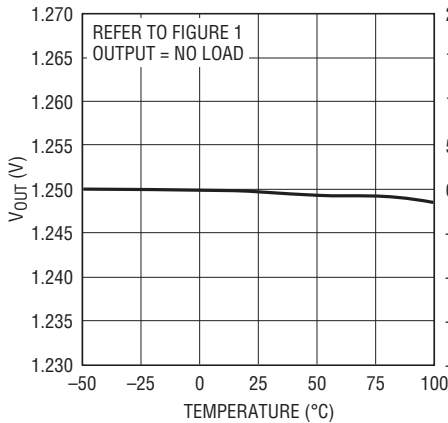

3831 G04

### Error Amplifier Sink/Source Current vs Temperature

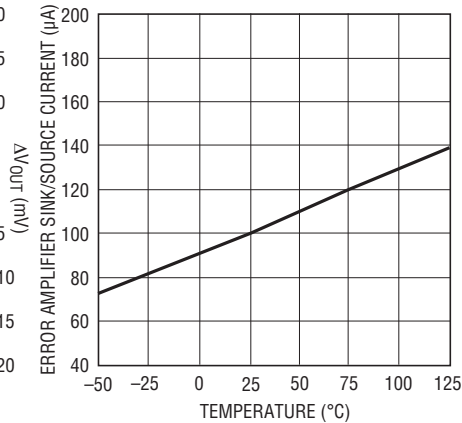

3831 G06

### Error Amplifier Open-Loop Gain vs Temperature

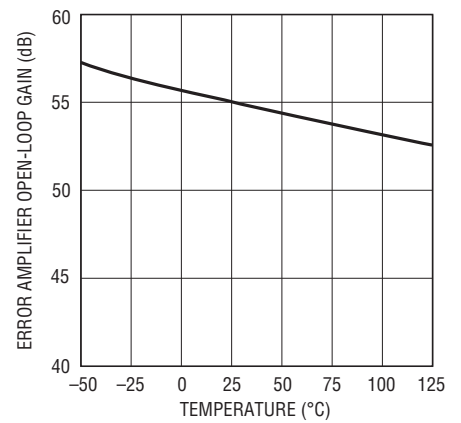

3831 G07

### Oscillator Frequency vs Temperature

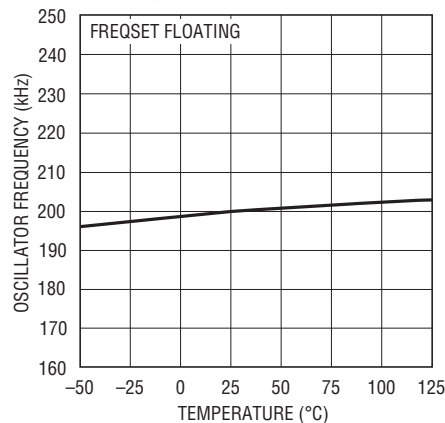

3831 G08

### Oscillator Frequency vs FREQSET Input Current

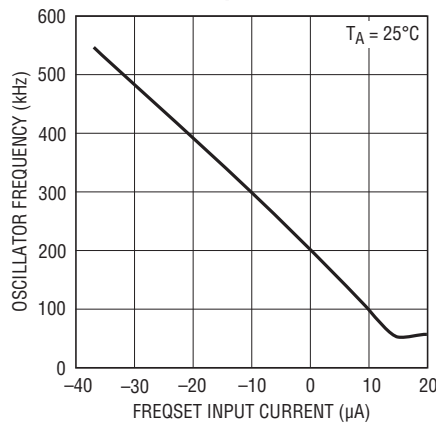

3831 G09

### Oscillator ( $V_{SAWH} - V_{SAWL}$ ) vs External Sync Frequency

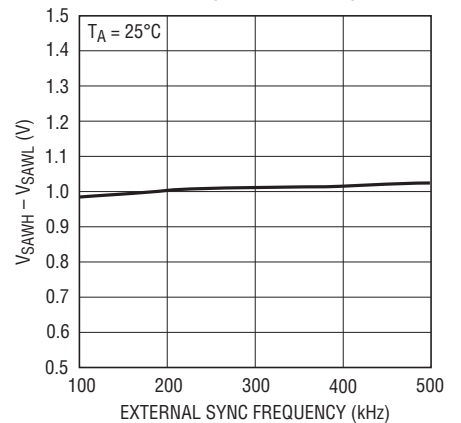

3831 G10

# TYPICAL PERFORMANCE CHARACTERISTICS

**Maximum TG Duty Cycle vs Temperature**

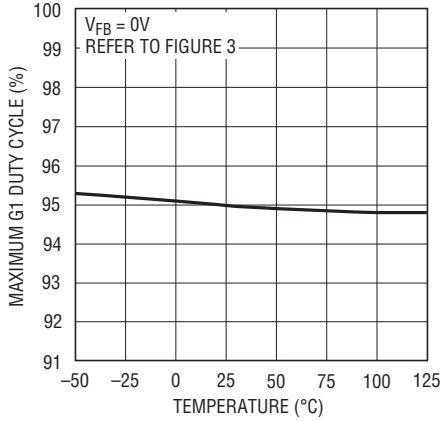

3831 G11

**I<sub>MAX</sub> Sink Current vs Temperature**

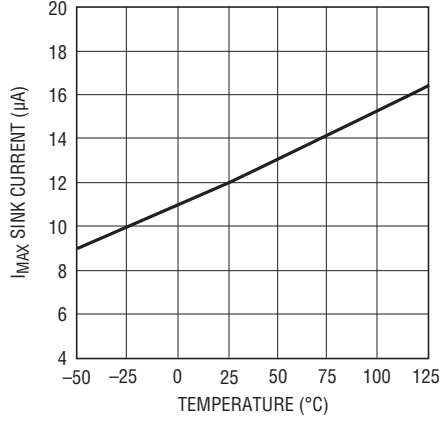

3831 G12

**Output Overcurrent Protection**

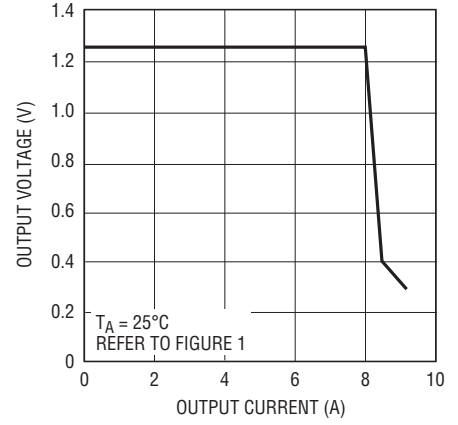

3831 G13

**Output Current Limit Threshold vs Temperature**

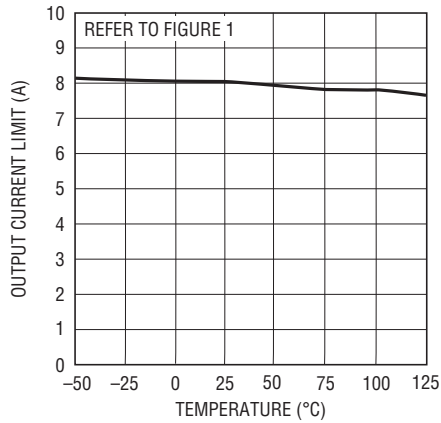

3831 G14

**Soft-Start Source Current vs Temperature**

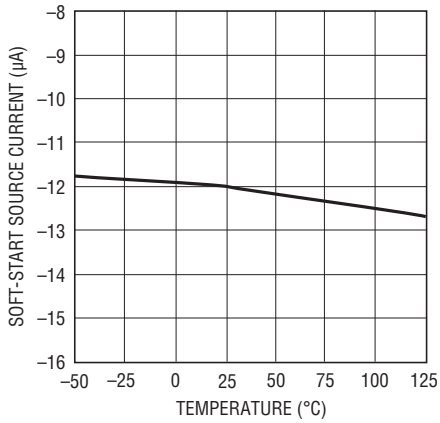

3831 G15

**Soft-Start Sink Current vs (V<sub>IFB</sub> - V<sub>IMAX</sub>)**

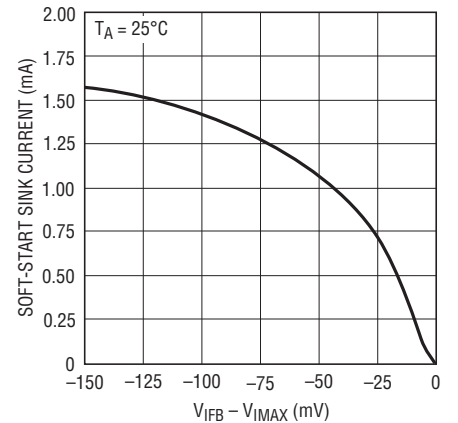

3831 G16

**Undervoltage Lockout Threshold Voltage vs Temperature**

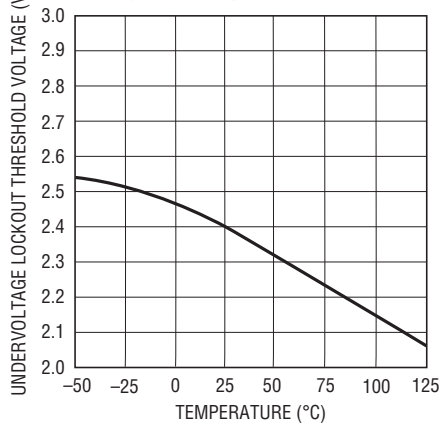

3831 G17

**V<sub>CC</sub> Operating Supply Current vs Temperature**

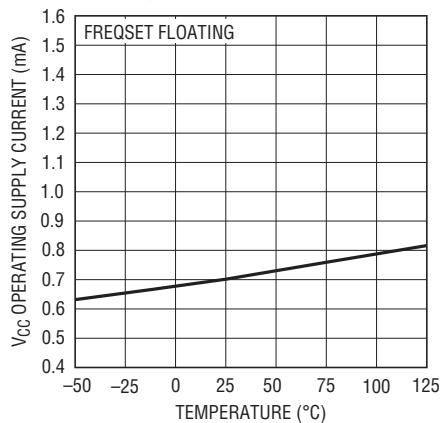

3831 G18

**PV<sub>CC</sub> Supply Current vs Oscillator Frequency**

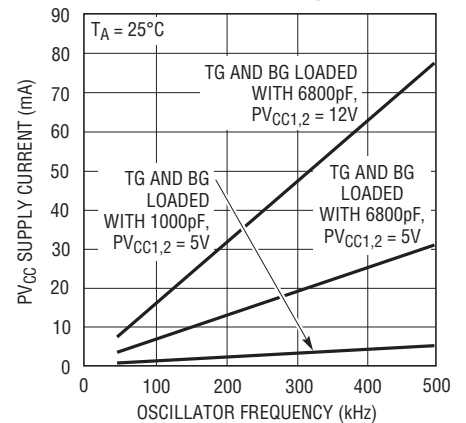

3831 G19

## TYPICAL PERFORMANCE CHARACTERISTICS

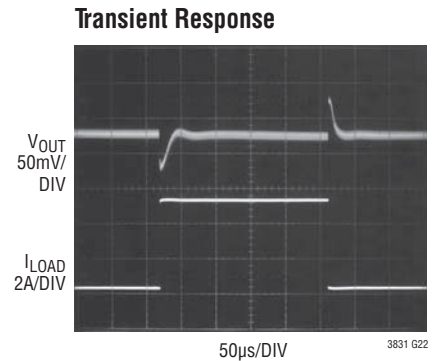
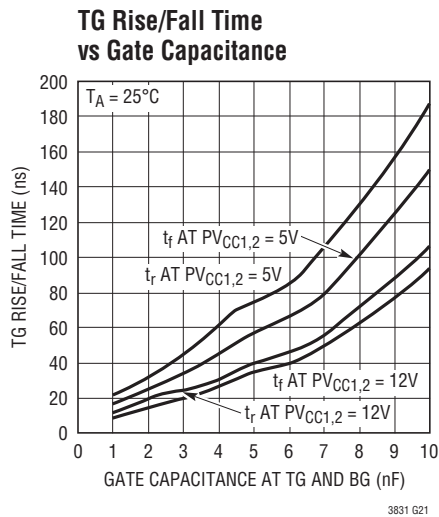
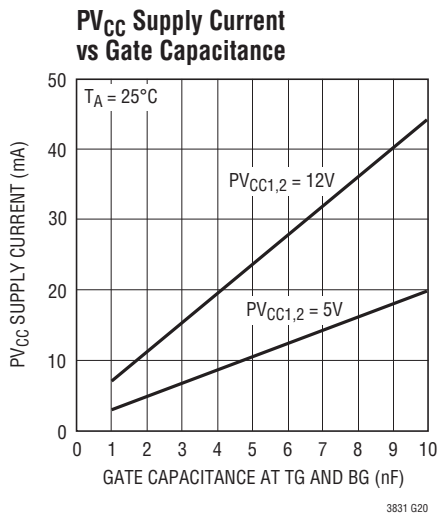

## PIN FUNCTIONS

**TG (Pin 1):** Top Driver Output. Connect this pin to the gate of the upper N-channel MOSFET, Q1. This output swings from PGND to PV<sub>CC1</sub>. It remains low if BG is high or during shutdown mode.

**PV<sub>CC1</sub> (Pin 2):** Power Supply Input for TG. Connect this pin to a potential of at least V<sub>IN</sub> + V<sub>GS(ON)(Q1)</sub>. This potential can be generated using an external supply or a simple charge pump connected to the switching node between the upper MOSFET and the lower MOSFET.

**PGND (Pin 3):** Power Ground. Both drivers return to this pin. Connect this pin to a low impedance ground in close proximity to the source of Q2. Refer to the Layout Consideration section for more details on PCB layout techniques.

**GND (Pin 4):** Signal Ground. All low power internal circuitry returns to this pin. To minimize regulation errors due to ground currents, connect GND to PGND right at the LTC3831.

**R<sup>-</sup>, R<sup>+</sup> (Pins 5, 7):** These two pins connect to the internal resistor divider that generate the internal ratiometric reference for the error amplifier. The reference voltage is set at 0.5 • (V<sub>R+</sub> – V<sub>R-</sub>).

**FB (Pin 6):** Feedback Voltage. FB senses the regulated output voltage either directly or through an external

resistor divider. The FB pin is servoed to the ratiometric reference under closed-loop conditions. The LTC3831 can operate with a minimum V<sub>FB</sub> of 1.1V and maximum V<sub>FB</sub> of (V<sub>CC</sub> – 1.75V).

**SHDN (Pin 8):** Shutdown. A TTL compatible low level at SHDN for longer than 100µs puts the LTC3831 into shutdown mode. In shutdown, TG and BG go low, all internal circuits are disabled and the quiescent current drops to 10µA max. A TTL compatible high level at SHDN allows the part to operate normally. This pin also double as an external clock input to synchronize the internal oscillator with an external clock.

**SS (Pin 9):** Soft-Start. Connect this pin to an external capacitor, C<sub>SS</sub>, to implement a soft-start function. If the LTC3831 goes into current limit, C<sub>SS</sub> is discharged to reduce the duty cycle. C<sub>SS</sub> must be selected such that during power-up, the current through Q1 will not exceed the current limit level.

**COMP (Pin 10):** External Compensation. This pin internally connects to the output of the error amplifier and input of the PWM comparator. Use a RC + C network at this pin to compensate the feedback loop to provide optimum transient response.

## PIN FUNCTIONS

**FREQSET (Pin 11):** Frequency Set. Use this pin to adjust the free-running frequency of the internal oscillator. With the pin floating, the oscillator runs at about 200kHz. A resistor from FREQSET to ground speeds up the oscillator; a resistor to  $V_{CC}$  slows it down.

**$I_{MAX}$  (Pin 12):** Current Limit Threshold Set.  $I_{MAX}$  sets the threshold for the internal current limit comparator. If  $I_{FB}$  drops below  $I_{MAX}$  with TG on, the LTC3831 goes into current limit.  $I_{MAX}$  has an internal  $12\mu A$  pull-down to GND. Connect this pin to the main  $V_{IN}$  supply at the drain of Q1, through an external resistor to set the current limit threshold. Connect a  $0.1\mu F$  decoupling capacitor across this resistor to filter switching noise.

**$I_{FB}$  (Pin 13):** Current Limit Sense. Connect this pin to the switching node at the source of Q1 and the drain of Q2

through a  $1k$  resistor. The  $1k$  resistor is required to prevent voltage transients from damaging  $I_{FB}$ . This pin is used for sensing the voltage drop across the upper N-channel MOSFET, Q1.

**$V_{CC}$  (Pin 14):** Power Supply Input. All low power internal circuits draw their supply from this pin. This pin requires a  $4.7\mu F$  bypass capacitor to GND.

**$PV_{CC2}$  (Pin 15):** Power Supply Input for BG. Connect this pin to the main high power supply.

**BG (Pin 16):** Bottom Driver Output. Connect this pin to the gate of the lower N-channel MOSFET, Q2. This output swings from PGND to  $PV_{CC2}$ . It remains low when TG is high or during shutdown mode. To prevent output undershoot during a soft-start cycle, BG is held low until TG first goes high (FFBG in the Block Diagram).

## BLOCK DIAGRAM

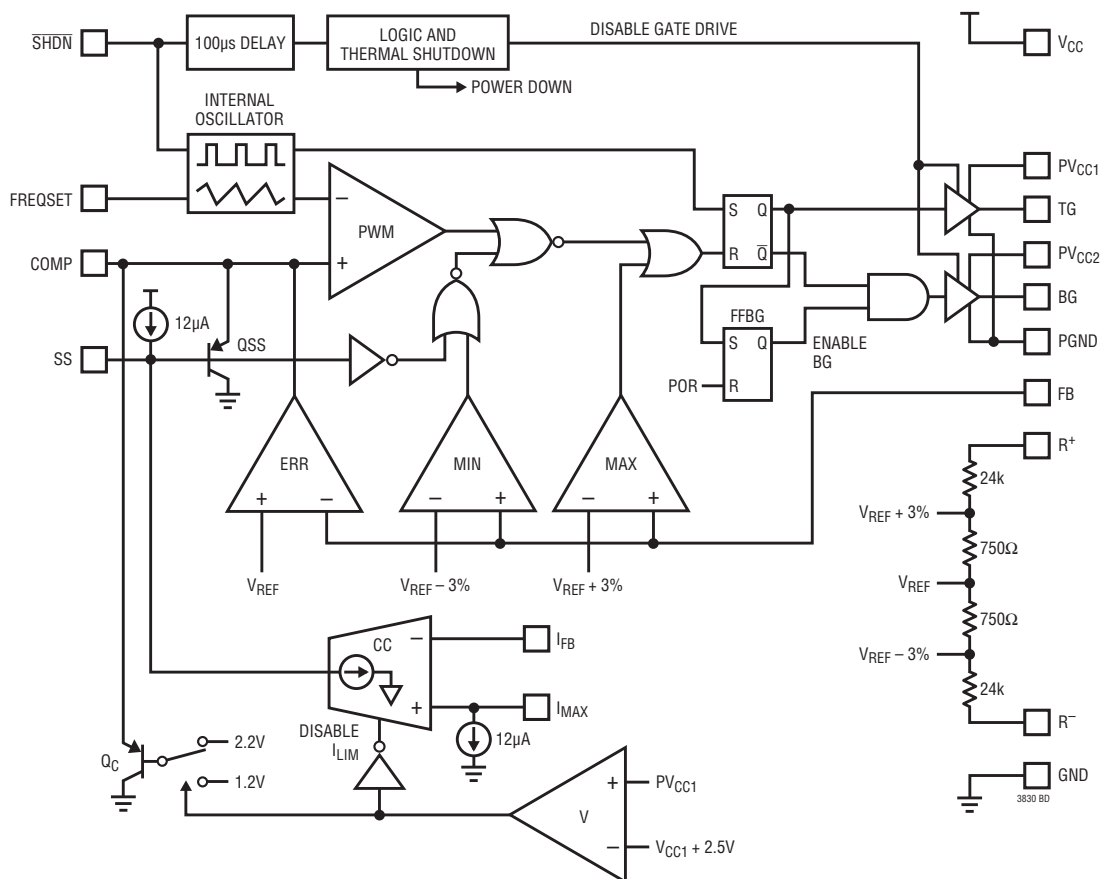

## TEST CIRCUITS

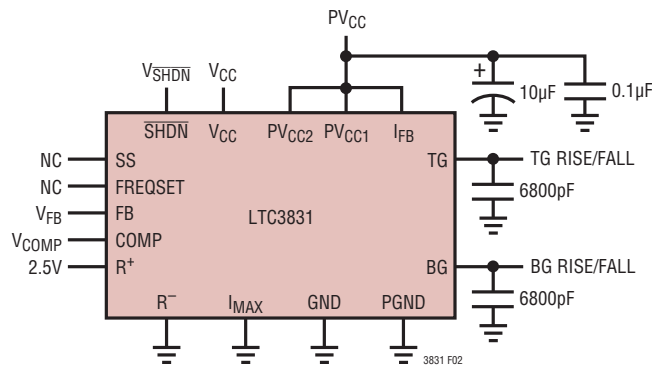

Figure 2

## APPLICATIONS INFORMATION

## OVERVIEW

The LTC3831 is a voltage mode feedback, synchronous switching regulator controller (see Block Diagram) designed for use in high to medium power, DDR memory termination. It includes an onboard PWM generator, a ratiometric reference, two high power MOSFET gate drivers and all necessary feedback and control circuitry to form a complete switching regulator circuit. The PWM loop nominally runs at 200kHz.

The LTC3831 is designed to generate an output voltage that tracks at 1/2 of the external voltage connected between the R<sup>+</sup> and R<sup>-</sup> pins. The LTC3831 can be used to generate the termination voltage, V<sub>TT</sub>, for interface like the SSTL\_2 where V<sub>TT</sub> is a ratio of the interface supply voltage, V<sub>DDQ</sub>. It is a requirement in the SSTL\_2 interface standard for V<sub>TT</sub> to track the interface supply voltage to improve noise immunity. Using the LTC3831 to supply the interface termination voltage allows large current sourcing and sinking through the termination resistors during bus transitions.

The LTC3831 includes a current limit sensing circuit that uses the topside external N-channel power MOSFET as a current sensing element, eliminating the need for an external sense resistor. Also included is an internal soft-start feature that requires only a single external capacitor to operate. In addition, the part features an adjustable oscillator which can free run or synchronize to an external signal with frequencies from 100kHz to 500kHz, allowing added flexibility in external component selection.

## THEORY OF OPERATION

## Primary Feedback Loop

The LTC3831 senses the output voltage of the circuit through the FB pin and feeds this voltage back to the internal transconductance error amplifier, ERR. The error amplifier compares the output voltage to the internal ratiometric reference, V<sub>REF</sub> and outputs an error signal to the PWM comparator. V<sub>REF</sub> is set to 0.5 multiplied by the voltage difference between the R<sup>+</sup> and R<sup>-</sup> pins, using an internal resistor divider.

This error signal is compared with a fixed frequency ramp waveform, from the internal oscillator, to generate a pulse width modulated signal. This PWM signal drives the external MOSFETs through the TG and BG pins. The resulting chopped waveform is filtered by L<sub>O</sub> and C<sub>OUT</sub> which closes the loop. Loop compensation is achieved with an external compensation network at the COMP pin, the output node of the error amplifier.

## MIN, MAX Feedback Loops

Two additional comparators in the feedback loop provide high speed output voltage correction in situations where the error amplifier may not respond quickly enough. MIN compares the feedback signal to a voltage 3% below V<sub>REF</sub>. If the signal is below the comparator threshold, the MIN comparator overrides the error amplifier and forces the loop to maximum duty cycle, >91%. Similarly, the MAX comparator forces the output to 0% duty cycle if the feed-

## APPLICATIONS INFORMATION

back signal is greater than 3% above  $V_{REF}$ . To prevent these two comparators from triggering due to noise, the MIN and MAX comparators' response times are deliberately delayed by two to three microseconds. These two comparators help prevent extreme output perturbations with fast output load current transients, while allowing the main feedback loop to be optimally compensated for stability.

### Thermal Shutdown

The LTC3831 has a thermal protection circuit that disables both gate drivers if activated. If the chip junction temperature reaches 150°C, both TG and BG are pulled low. TG and BG remain low until the junction temperature drops below 125°C, after which, the chip resumes normal operation.

### Soft-Start and Current Limit

The LTC3831 includes a soft-start circuit that is used for start-up and current limit operation. The SS pin requires an external capacitor,  $C_{SS}$ , to GND with the value determined by the required soft-start time. An internal 12 $\mu$ A current source is included to charge  $C_{SS}$ . During power-up, the COMP pin is clamped to a diode drop (B-E junction of QSS in the Block Diagram) above the voltage at the SS pin. This prevents the error amplifier from forcing the loop to maximum duty cycle. The LTC3831 operates at low duty cycle as the SS pin rises above 0.6V ( $V_{COMP} \approx 1.2V$ ). As SS continues to rise, Q<sub>SS</sub> turns off and the error amplifier takes over to regulate the output. The MIN comparator is disabled during soft-start to prevent it from overriding the soft-start function.

The LTC3831 includes yet another feedback loop to control operation in current limit. Just before every falling edge of TG, the current comparator, CC, samples and holds the voltage drop measured across the external upper MOSFET, Q1, at the I<sub>FB</sub> pin. CC compares the voltage at I<sub>FB</sub> to the voltage at the I<sub>MAX</sub> pin. As the peak current rises, the measured voltage across Q1 increases due to the drop across the  $R_{DS(ON)}$  of Q1. When the voltage at I<sub>FB</sub> drops below I<sub>MAX</sub>, indicating that Q1's drain current has exceeded the maximum level, CC starts to pull current out of  $C_{SS}$ , cutting the duty cycle and controlling the output current level. The CC comparator pulls current out of the SS pin

in proportion to the voltage difference between I<sub>FB</sub> and I<sub>MAX</sub>. Under minor overload conditions, the SS pin falls gradually, creating a time delay before current limit takes effect. Very short, mild overloads may not affect the output voltage at all. More significant overload conditions allow the SS pin to reach a steady state, and the output remains at a reduced voltage until the overload is removed. Serious overloads generate a large overdrive at CC, allowing it to pull SS down quickly and preventing damage to the output components. By using the  $R_{DS(ON)}$  of Q1 to measure the output current, the current limiting circuit eliminates an expensive discrete sense resistor that would otherwise be required. This helps minimize the number of components in the high current path.

The current limit threshold can be set by connecting an external resistor  $R_{I_{MAX}}$  from the I<sub>MAX</sub> pin to the main  $V_{IN}$  supply at the drain of Q1. The value of  $R_{I_{MAX}}$  is determined by:

$$R_{I_{MAX}} = (I_{L_{MAX}})(R_{DS(ON)Q1})/I_{I_{MAX}}$$

where:

$$I_{L_{MAX}} = I_{LOAD} + (I_{RIPPLE}/2)$$

$$I_{LOAD} = \text{Maximum load current}$$

$$I_{RIPPLE} = \text{Inductor ripple current}$$

$$= \frac{(V_{IN} - V_{OUT})(V_{OUT})}{(f_{OSC})(L_O)(V_{IN})}$$

$$f_{OSC} = \text{LTC3831 oscillator frequency} = 200\text{kHz}$$

$$L_O = \text{Inductor value}$$

$$R_{DS(ON)Q1} = \text{On-resistance of Q1 at } I_{L_{MAX}}$$

$$I_{I_{MAX}} = \text{Internal } 12\mu\text{A sink current at } I_{MAX}$$

The  $R_{DS(ON)}$  of Q1 usually increases with temperature. To keep the current limit threshold constant, the internal 12 $\mu$ A sink current at I<sub>MAX</sub> is designed with a positive temperature coefficient to provide first order correction for the temperature coefficient of  $R_{DS(ON)Q1}$ .

In order for the current limit circuit to operate properly and to obtain a reasonably accurate current limit threshold, the I<sub>MAX</sub> and I<sub>FB</sub> pins must be Kelvin sensed at Q1's drain

## APPLICATIONS INFORMATION

and source pins. In addition, connect a 0.1 $\mu$ F decoupling capacitor across  $R_{I_{MAX}}$  to filter switching noise. Otherwise, noise spikes or ringing at Q1's source can cause the actual current limit to be greater than the desired current limit set point. Due to switching noise and variation of  $R_{DS(ON)}$ , the actual current limit trip point is not highly accurate. The current limiting circuitry is primarily meant to prevent damage to the power supply circuitry during fault conditions. The exact current level where the limiting circuit begins to take effect will vary from unit to unit as the  $R_{DS(ON)}$  of Q1 varies. Typically,  $R_{DS(ON)}$  varies as much as  $\pm 40\%$  and with  $\pm 25\%$  variation on the LTC3831's  $I_{MAX}$  current, this can give a  $\pm 65\%$  variation on the current limit threshold.

The  $R_{DS(ON)}$  is high if the  $V_{GS}$  applied to the MOSFET is low. This occurs during power up, when  $PV_{CC1}$  is ramping up. To prevent the high  $R_{DS(ON)}$  from activating the current limit, the LTC3831 disables the current limit circuit if  $PV_{CC1}$  is less than 2.5V above  $V_{CC}$ . To ensure proper operation of the current limit circuit,  $PV_{CC1}$  must be at least 2.5V above  $V_{CC}$  when TG is high.  $PV_{CC1}$  can go low when TG is low, allowing the use of an external charge pump to power  $PV_{CC1}$ .

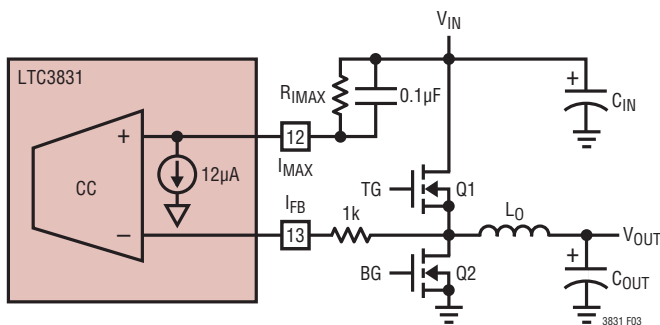

Figure 3. Current Limit Setting

### Oscillator Frequency

The LTC3831 includes an onboard current controlled oscillator that typically free-runs at 200kHz. The oscillator frequency can be adjusted by forcing current into or out of the FREQSET pin. With the pin floating, the oscillator runs at about 200kHz. Every additional 1 $\mu$ A of current into/out of the FREQSET pin decreases/increases the frequency by 10kHz. The pin is internally servoed to 1.265V, connect-

ing a 50k resistor from FREQSET to ground forces 25 $\mu$ A out of the pin, causing the internal oscillator to run at approximately 450kHz. Forcing an external 10 $\mu$ A current into FREQSET cuts the internal frequency to 100kHz. An internal clamp prevents the oscillator from running slower than about 50kHz. Tying FREQSET to  $V_{CC}$  forces the chip to run at this minimum speed.

### Shutdown

The LTC3831 includes a low power shutdown mode, controlled by the logic at the  $\overline{SHDN}$  pin. A high at  $\overline{SHDN}$  allows the part to operate normally. A low level at  $\overline{SHDN}$  for more than 100 $\mu$ s forces the LTC3831 into shutdown mode. In this mode, all internal switching stops, the COMP and SS pins pull to ground and Q1 and Q2 turn off. The LTC3831 supply current drops to <10 $\mu$ A, although off-state leakage in the external MOSFETs may cause the total  $V_{IN}$  current to be somewhat higher, especially at elevated temperatures. If  $\overline{SHDN}$  returns high, the LTC3831 reruns a soft-start cycle and resumes normal operation.

### External Clock Synchronization

The LTC3831  $\overline{SHDN}$  pin doubles as an external clock input for applications that require a synchronized clock. An internal circuit forces the LTC3831 into external synchronization mode if a negative transition at the  $\overline{SHDN}$  pin is detected. In this mode, every negative transition on the  $\overline{SHDN}$  pin resets the internal oscillator and pulls the ramp signal low. This forces the LTC3831 internal oscillator to lock to the external clock frequency.

The LTC3831 internal oscillator can be externally synchronized from 100kHz to 500kHz. Frequencies above 300kHz can cause a decrease in the maximum obtainable duty cycle as rise/fall time and propagation delay take up a larger percentage of the switch cycle. The low period of this clock signal must not be >100 $\mu$ s or else the LTC3831 enters into the shutdown mode.

Figure 4 describes the operation of the external synchronization function. A negative transition at the  $\overline{SHDN}$  pin forces the internal ramp signal low to restart a new PWM cycle. Notice that the ramp amplitude is lowered as the external clock frequency goes higher. The effect of this decrease in ramp amplitude increases the open-loop gain of the

## APPLICATIONS INFORMATION

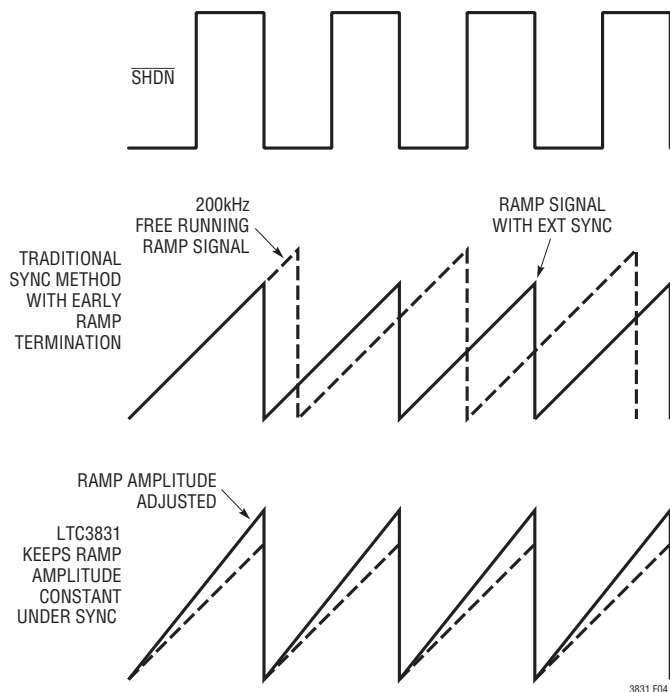

Figure 4. External Synchronization Operation

controller feedback loop. As a result, the loop crossover frequency increases and it may cause the feedback loop to be unstable if the phase margin is insufficient.

To overcome this problem, the LTC3831 monitors the peak voltage of the ramp signal and adjust the oscillator charging current to maintain a constant ramp peak.

### Input Supply Considerations/Charge Pump

The LTC3831 requires four supply voltages to operate:  $V_{IN}$  for the main power input,  $PV_{CC1}$  and  $PV_{CC2}$  for MOSFET gate drive and a clean, low ripple  $V_{CC}$  for the LTC3831 internal circuitry (Figure 5).

In many applications,  $V_{CC}$  can be powered from  $V_{IN}$  through an RC filter. This supply can be as low as 3V. The low quiescent current (typically 800 $\mu$ A) allows the use of relatively large filter resistors and correspondingly small filter capacitors. 100 $\Omega$  and 4.7 $\mu$ F usually provide adequate filtering for  $V_{CC}$ . For best performance, connect the 4.7 $\mu$ F bypass capacitor as close to the LTC3831  $V_{CC}$  pin as possible.

Gate drive for the top N-channel MOSFET Q1 is supplied from  $PV_{CC1}$ . This supply must be above  $V_{IN}$  (the main power

supply input) by at least one power MOSFET  $V_{GS(ON)}$  for efficient operation. An internal level shifter allows  $PV_{CC1}$  to operate at voltages above  $V_{CC}$  and  $V_{IN}$ , up to 14V maximum. This higher voltage can be supplied with a separate supply, or it can be generated using a charge pump.

Gate drive for the bottom MOSFET Q2 is provided through  $PV_{CC2}$ . This supply only need to be above the power MOSFET  $V_{GS(ON)}$  for efficient operation.  $PV_{CC2}$  can also be driven from the same supply/charge pump for the  $PV_{CC1}$ , or it can be connected to a lower supply to improve efficiency.

Figure 6 shows a doubling charge pump circuit that can be used to provide  $2V_{IN}$  gate drive for Q1. The charge pump consists of a Schottky diode from  $V_{IN}$  to  $PV_{CC1}$  and a 0.1 $\mu$ F capacitor from  $PV_{CC1}$  to the switching node at the drain of Q2. This circuit provides  $2V_{IN} - V_F$  to  $PV_{CC1}$  while Q1 is ON and  $V_{IN} - V_F$  while Q1 is OFF where  $V_F$  is the forward voltage of the Schottky diode. Ringing at the drain of Q2 can cause transients above  $2V_{IN}$  at  $PV_{CC1}$ ; if  $V_{IN}$  is higher

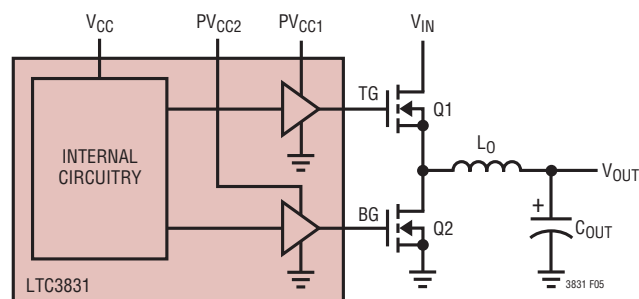

Figure 5. Supplies Input

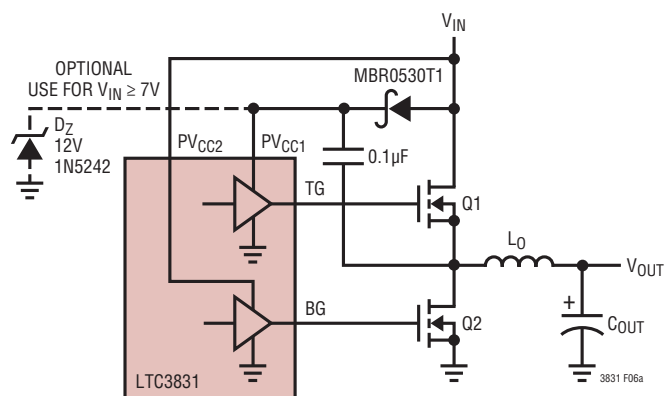

Figure 6. Doubling Charge Pump

## APPLICATIONS INFORMATION

than  $7V$ , a  $12V$  zener diode should be included from  $PV_{CC1}$  to  $PGND$  to prevent transients from damaging the circuitry at  $PV_{CC1}$  or the gate of  $Q1$ .

For applications with a lower  $V_{IN}$  supply, a tripling charge pump circuit shown in Figure 7 can be used to provide  $2V_{IN}$  and  $3V_{IN}$  gate drive for the external top and bottom MOSFETs respectively. This circuit provides  $3V_{IN} - 3V_F$  to  $PV_{CC1}$  while  $Q1$  is ON and  $2V_{IN} - 2V_F$  to  $PV_{CC2}$  where  $V_F$  is the forward voltage of the Schottky diode. The circuit requires the use of Schottky diodes to minimize forward drop across the diodes at start-up. The tripling charge pump circuit can rectify any ringing at the drain of  $Q2$  and provide more than  $3V_{IN}$  at  $PV_{CC1}$ ; a  $12V$  zener diode should be included from  $PV_{CC1}$  to  $PGND$  to prevent transients from damaging the circuitry at  $PV_{CC1}$  or the gate of  $Q1$ .

The charge pump capacitors for  $PV_{CC1}$  refresh when the  $BG$  pin goes high and the switch node is pulled low by  $Q2$ . The  $BG$  on time becomes narrow when the LTC3831 operates at maximum duty cycle (95% typical) which can occur if the input supply rises more slowly than the soft-start capacitor or the input voltage droops during load transients. If the  $BG$  on time gets so narrow that the switch node fails to pull completely to ground, the charge pump voltage may collapse or fail to start causing excessive dissipation in external MOSFET  $Q1$ . This is most likely with low  $V_{CC}$  voltages and high switching frequencies, coupled with large external MOSFETs that slow the  $BG$  and switch node slew rates.

The LTC3831 overcomes this problem by sensing the  $PV_{CC1}$  voltage when  $TG$  is high. If  $PV_{CC1}$  is less than  $2.5V$  above  $V_{CC}$ , the maximum  $TG$  duty cycle is reduced to 70% by clamping the  $COMP$  pin at  $1.8V$  ( $Q_C$  in the Block Diagram). This increases the  $BG$  on time and allows the charge pump capacitors to be refreshed.

For applications using an external supply to power  $PV_{CC1}$ , this supply must also be higher than  $V_{CC}$  by at least  $2.5V$  to ensure normal operation.

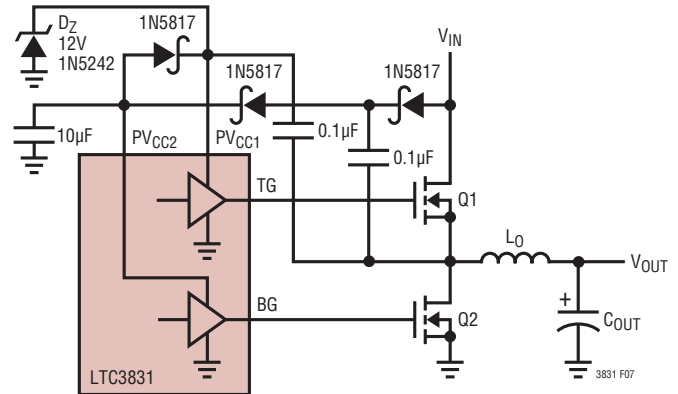

Figure 7. Tripling Charge Pump

### Connecting the Ratiometric Reference Input

The LTC3831 derives its ratiometric reference,  $V_{REF}$ , using an internal resistor divider. The top and bottom of the resistor divider is connected to the  $R^+$  and  $R^-$  pins respectively. This permits the output voltage to track at a ratio of the differential voltage at  $R^+$  and  $R^-$ .

The LTC3831 can operate with a minimum  $V_{FB}$  of  $1.1V$  and maximum  $V_{FB}$  of  $(V_{CC} - 1.75V)$ . With  $R^-$  connected to  $GND$ , this gives a  $V_{R^+}$  input range of  $2.2V$  to  $(2 \cdot V_{CC} - 3.5V)$ . If  $V_{R^+}$  is higher than the permitted input voltage, increase the  $V_{CC}$  voltage to raise the input range.

In a typical DDR memory termination application as shown in Figure 1,  $R^+$  is connected to  $V_{DDQ}$ , the supply voltage of the interface, and  $R^-$  to  $GND$ . The output voltage  $V_{TT}$  is connected to the  $FB$  pin, so  $V_{TT} = 0.5 \cdot V_{DDQ}$ .

If a ratio greater than 0.5 is desired, it can be achieved using an external resistor divider connected to  $V_{TT}$  and  $FB$  pin. Figure 8 shows an application that generates a  $V_{TT}$  of  $0.6 \cdot V_{DDQ}$ .

## APPLICATIONS INFORMATION

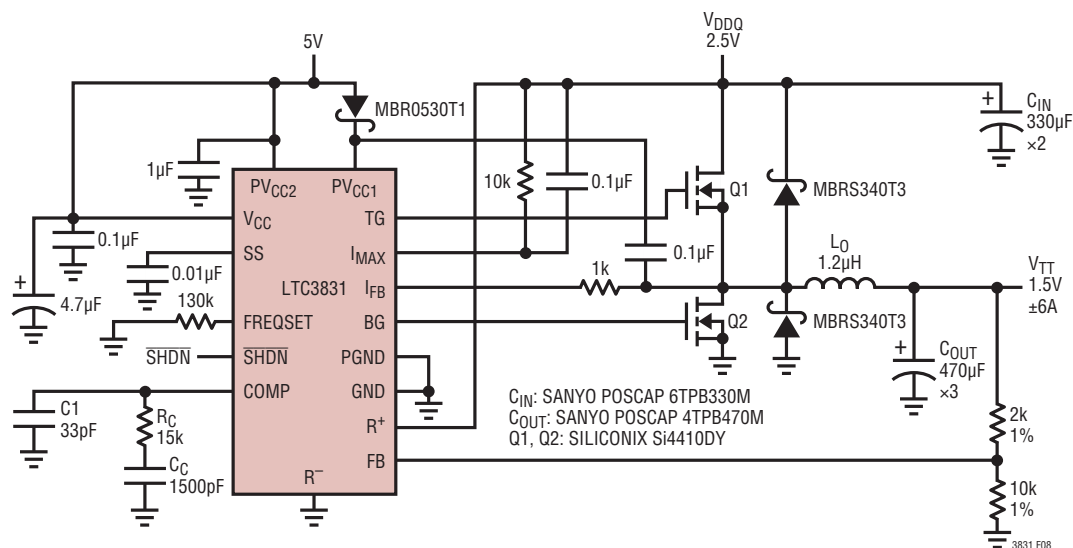

Figure 8. Typical Application with  $V_{TT} = 0.6 \cdot V_{DDQ}$

### Power MOSFETs

Two N-channel power MOSFETs are required for most LTC3831 circuits. These should be selected based primarily on threshold voltage and on-resistance considerations. Thermal dissipation is often a secondary concern in high efficiency designs. The required MOSFET threshold should be determined based on the available power supply voltages and/or the complexity of the gate drive charge pump scheme. In 3.3V input designs where an auxiliary 12V supply is available to power PV<sub>CC1</sub> and PV<sub>CC2</sub>, standard MOSFETs with R<sub>DS(ON)</sub> specified at V<sub>GS</sub> = 5V or 6V can be used with good results. The current drawn from this supply varies with the MOSFETs used and the LTC3831's operating frequency, but is generally less than 50mA.

LTC3831 applications that use 5V or lower V<sub>IN</sub> voltage and doubling/tripling charge pumps to generate PV<sub>CC1</sub> and PV<sub>CC2</sub>, do not provide enough gate drive voltage to fully enhance standard power MOSFETs. Under this condition, the effective MOSFET R<sub>DS(ON)</sub> may be quite high, raising the dissipation in the FETs and reducing efficiency. Logic-level FETs are the recommended choice for 5V or lower voltage systems. Logic-level FETs can be fully enhanced with a doubler/tripling charge pump and will operate at maximum efficiency.

After the MOSFET threshold voltage is selected, choose the R<sub>DS(ON)</sub> based on the input voltage, the output voltage, allowable power dissipation and maximum output current. In a typical LTC3831 circuit operating in continuous mode, the average inductor current is equal to the output load current. This current flows through either Q1 or Q2 with the power dissipation split up according to the duty cycle:

$$DC(Q1) = \frac{V_{OUT}}{V_{IN}}$$

$$DC(Q2) = 1 - \frac{V_{OUT}}{V_{IN}} = \frac{V_{IN} - V_{OUT}}{V_{IN}}$$

The R<sub>DS(ON)</sub> required for a given conduction loss can now be calculated by rearranging the relation  $P = I^2R$ .

$$R_{DS(ON)Q1} = \frac{P_{MAX(Q1)}}{DC(Q1) \cdot (I_{LOAD})^2} = \frac{V_{IN} \cdot P_{MAX(Q1)}}{V_{OUT} \cdot (I_{LOAD})^2}$$

$$R_{DS(ON)Q2} = \frac{P_{MAX(Q2)}}{DC(Q2) \cdot (I_{LOAD})^2} = \frac{V_{IN} \cdot P_{MAX(Q2)}}{(V_{IN} - V_{OUT}) \cdot (I_{LOAD})^2}$$

P<sub>MAX</sub> should be calculated based primarily on required efficiency or allowable thermal dissipation. A typical high efficiency circuit designed for 2.5V input and 1.25V at 5A

## APPLICATIONS INFORMATION

output might allow no more than 3% efficiency loss at full load for each MOSFET. Assuming roughly 90% efficiency at this current level, this gives a  $P_{MAX}$  value of:

$$(1.25V)(5A/0.9)(0.03) = 0.21W \text{ per FET}$$

and a required  $R_{DS(ON)}$  of:

$$R_{DS(ON)Q1} = \frac{(2.5V) \cdot (0.21W)}{(1.25V)(5A)^2} = 0.017\Omega$$

$$R_{DS(ON)Q2} = \frac{(2.5V) \cdot (0.21W)}{(2.5V - 1.25V)(5A)^2} = 0.017\Omega$$

Note that while the required  $R_{DS(ON)}$  values suggest large MOSFETs, the power dissipation numbers are only 0.21W per device or less; large TO-220 packages and heat sinks are not necessarily required in high efficiency applications. Siliconix Si4410DY or International Rectifier IRF7413 (both in SO-8) or Siliconix SUD50N03-10 (TO-252) or ON Semiconductor MTD20N03HDL (DPAK) are small footprint surface mount devices with  $R_{DS(ON)}$  values below  $0.03\Omega$  at 5V of  $V_{GS}$  that work well in LTC3831 circuits. Using a

higher  $P_{MAX}$  value in the  $R_{DS(ON)}$  calculations generally decreases the MOSFET cost and the circuit efficiency and increases the MOSFET heat sink requirements.

Table 1 highlights a variety of power MOSFETs that are for use in LTC3831 applications.

### Inductor Selection

The inductor is often the largest component in an LTC3831 design and must be chosen carefully. Choose the inductor value and type based on output slew rate requirements. The maximum rate of rise of inductor current is set by the inductor's value, the input-to-output voltage differential and the LTC3831's maximum duty cycle. In a typical 2.5V input 1.25V output application, the maximum rise time will be:

$$\frac{DC_{MAX} \cdot (V_{IN} - V_{OUT})}{L_0} = \frac{1.138}{L_0} \frac{A}{\mu S}$$

where  $L_0$  is the inductor value in  $\mu H$ . With proper frequency compensation, the combination of the inductor and output

**Table 1. Recommended MOSFETs for LTC3831 Applications**

PARTS	$R_{DS(ON)}$ AT 25°C (m $\Omega$ )	RATED CURRENT (A)	TYPICAL INPUT CAPACITANCE $C_{ISS}$ (pF)	$\theta_{JC}$ (°C/W)	$T_{JMAX}$ (°C)
Siliconix SUD50N03-10 TO-252	19	15 at 25°C 10 at 100°C	3200	1.8	175
Siliconix Si4410DY SO-8	20	10 at 25°C 8 at 70°C	2700		150
ON Semiconductor MTD20N03HDL D PAK	35	20 at 25°C 16 at 100°C	880	1.67	150
Fairchild FDS6670A SO-8	8	13 at 25°C	3200	25	150
Fairchild FDS6680 SO-8	10	11.5 at 25°C	2070	25	150
ON Semiconductor MTB75N03HDL DS PAK	9	75 at 25°C 59 at 100°C	4025	1	150
IR IRL3103S DD PAK	19	64 at 25°C 45 at 100°C	1600	1.4	175
IR IRLZ44 TO-220	28	50 at 25°C 36 at 100°C	3300	1	175
Fuji 2SK1388 TO-220	37	35 at 25°C	1750	2.08	150

Note: Please refer to the manufacturer's data sheet for testing conditions and detailed information.

## APPLICATIONS INFORMATION

capacitor values determine the transient recovery time. In general, a smaller value inductor improves transient response at the expense of ripple and inductor core saturation rating. A 2 $\mu$ H inductor has a 0.57A/ $\mu$ s rise time in this application, resulting in a 8.8 $\mu$ s delay in responding to a 5A load current step. During this 8.8 $\mu$ s, the difference between the inductor current and the output current is made up by the output capacitor. This action causes a temporary voltage droop at the output. To minimize this effect, the inductor value should usually be in the 1 $\mu$ H to 5 $\mu$ H range for most LTC3831 circuits. To optimize performance, different combinations of input and output voltages and expected loads may require different inductor values.

Once the required value is known, the inductor core type can be chosen based on peak current and efficiency requirements. Peak current in the inductor will be equal to the maximum output load current plus half of the peak-to-peak inductor ripple current. Ripple current is set by the inductor value, the input and output voltage and the operating frequency. The ripple current is approximately equal to:

$$I_{\text{RIPPLE}} = \frac{(V_{\text{IN}} - V_{\text{OUT}}) \cdot (V_{\text{OUT}})}{f_{\text{OSC}} \cdot L_0 \cdot V_{\text{IN}}}$$

$$f_{\text{OSC}} = \text{LTC3831 oscillator frequency} = 200\text{kHz}$$

$$L_0 = \text{Inductor value}$$

Solving this equation with our typical 2.5V to 1.25V application with 2 $\mu$ H inductor, we get:

$$\frac{(2.5\text{V} - 1.25\text{V}) \cdot 1.25\text{V}}{200\text{kHz} \cdot 2\mu\text{H} \cdot 2.5\text{V}} = 1.56\text{A}_{\text{P-P}}$$

Peak inductor current at 5A load:

$$5\text{A} + (1.56\text{A}/2) = 5.78\text{A}$$

The ripple current should generally be between 10% and 40% of the output current. The inductor must be able to withstand this peak current without saturating, and the copper resistance in the winding should be kept as low as possible to minimize resistive power loss. Note that in circuits not employing the current limit function, the current in the inductor may rise above this maximum under

short circuit or fault conditions; the inductor should be sized accordingly to withstand this additional current. Inductors with gradual saturation characteristics are often the best choice.

### Input and Output Capacitors

A typical LTC3831 design places significant demands on both the input and the output capacitors. During normal steady load operation, a buck converter like the LTC3831 draws square waves of current from the input supply at the switching frequency. The peak current value is equal to the output load current plus 1/2 the peak-to-peak ripple current. Most of this current is supplied by the input bypass capacitor. The resulting RMS current flow in the input capacitor heats it and causes premature capacitor failure in extreme cases. Maximum RMS current occurs with 50% PWM duty cycle, giving an RMS current value equal to  $I_{\text{OUT}}/2$ . A low ESR input capacitor with an adequate ripple current rating must be used to ensure reliable operation. Note that capacitor manufacturers' ripple current ratings are often based on only 2000 hours (3 months) lifetime at rated temperature. Further derating of the input capacitor ripple current beyond the manufacturer's specification is recommended to extend the useful life of the circuit. Lower operating temperature has the largest effect on capacitor longevity.

The output capacitor in a buck converter under steady-state conditions sees much less ripple current than the input capacitor. Peak-to-peak current is equal to inductor ripple current, usually 10% to 40% of the total load current. Output capacitor duty places a premium not on power dissipation but on ESR. During an output load transient, the output capacitor must supply all of the additional load current demanded by the load until the LTC3831 adjusts the inductor current to the new value. ESR in the output capacitor results in a step in the output voltage equal to the ESR value multiplied by the change in load current. A 5A load step with a 0.05 $\Omega$  ESR output capacitor results in a 250mV output voltage shift; this is 20% of the output voltage for a 1.25V supply! Because of the strong relationship between output capacitor ESR and output load transient response, choose the output capacitor for ESR,

## APPLICATIONS INFORMATION

not for capacitance value. A capacitor with suitable ESR will usually have a larger capacitance value than is needed to control steady-state output ripple.

Electrolytic capacitors, such as the Sanyo MV-WX series, rated for use in switching power supplies with specified ripple current ratings and ESR, can be used effectively in LTC3831 applications. OS-CON electrolytic capacitors from Sanyo and other manufacturers give excellent performance and have a very high performance/size ratio for electrolytic capacitors. Surface mount applications can use either electrolytic or dry tantalum capacitors. Tantalum capacitors must be surge tested and specified for use in switching power supplies. Low cost, generic tantalums are known to have very short lives followed by explosive deaths in switching power supply applications. Other capacitor series that can be used include Sanyo POSCAPs and the Panasonic SP line.

A common way to lower ESR and raise ripple current capability is to parallel several capacitors. A typical LTC3831 application might exhibit 5A input ripple current. Sanyo OS-CON capacitors, part number 10SA220M (220 $\mu$ F/10V), feature 2.3A allowable ripple current at 85°C; three in parallel at the input (to withstand the input ripple current) meet the above requirements. Similarly, Sanyo POSCAP 4TPB470M (470 $\mu$ F/4V) capacitors have a maximum rated ESR of 0.04 $\Omega$ , three in parallel lower the net output capacitor ESR to 0.013 $\Omega$ .

### Feedback Loop Compensation

The LTC3831 voltage feedback loop is compensated at the COMP pin, which is the output node of the error amplifier. The feedback loop is generally compensated with an RC + C network from COMP to GND as shown in Figure 9a.

Loop stability is affected by the values of the inductor, the output capacitor, the output capacitor ESR, the error amplifier transconductance and the error amplifier compensation network. The inductor and the output capacitor create a double pole at the frequency:

$$f_{LC} = 1 / [2\pi\sqrt{(L_O)(C_{OUT})}]$$

The ESR of the output capacitor and the output capacitor value form a zero at the frequency:

$$f_{ESR} = 1 / [2\pi(ESR)(C_{OUT})]$$

The compensation network used with the error amplifier must provide enough phase margin at the 0dB crossover frequency for the overall open-loop transfer function. The zero and pole from the compensation network are:

$$f_Z = 1/[2\pi(R_C)(C_C)] \text{ and}$$

$$f_P = 1/[2\pi(R_C)(C_1)] \text{ respectively.}$$

Figure 9b shows the Bode plot of the overall transfer function.

Although a mathematical approach to frequency compensation can be used, the added complication of input and/or output filters, unknown capacitor ESR, and gross operating

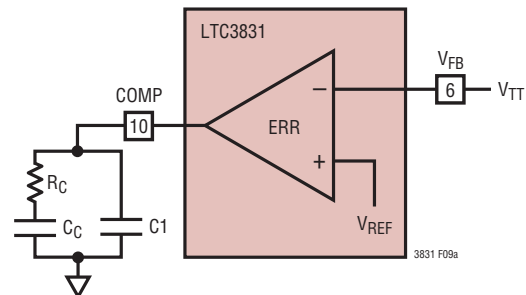

Figure 9a. Compensation Pin Hook-Up

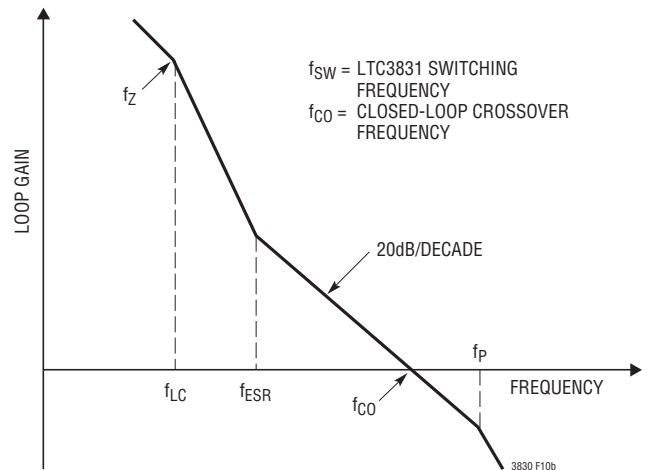

Figure 9b. Bode Plot of the LTC3831 Overall Transfer Function

## APPLICATIONS INFORMATION

point changes with input voltage, load current variations, all suggest a more practical empirical method. This can be done by injecting a transient current at the load and using an RC network box to iterate toward the final values, or by obtaining the optimum loop response using a network analyzer to find the actual loop poles and zeros.

Table 2 shows the suggested compensation component value for 2.5V to 1.25V applications based on the 470 $\mu$ F Sanyo POSCAP 4TPB470M output capacitors.

Table 3 shows the suggested compensation component values for 2.5V to 1.25V applications based on 1500 $\mu$ F Sanyo MV-WX output capacitors.

**Table 2. Recommended Compensation Network for 2.5V to 1.25V Applications Using Multiple Paralleled 470 $\mu$ F Sanyo POSCAP 4TPB470M Output Capacitors**

L1 ( $\mu$ H)	C <sub>OUT</sub> ( $\mu$ F)	R <sub>C</sub> (k $\Omega$ )	C <sub>C</sub> (nF)	C1(pF)
1.2	1410	6.8	3.3	33
1.2	2820	15	3.3	33
1.2	4700	22	1.5	33
2.4	1410	15	10	33
2.4	2820	36	3.3	10
2.4	4700	47	4.7	10
4.7	1410	33	10	10
4.7	2820	68	22	10
4.7	4700	120	10	10

**Table 3. Recommended Compensation Network for 2.5V to 1.25V Applications Using Multiple Paralleled 1500 $\mu$ F Sanyo MV-WX Output Capacitors**

L1 ( $\mu$ H)	C <sub>OUT</sub> ( $\mu$ F)	R <sub>C</sub> (k $\Omega$ )	C <sub>C</sub> (nF)	C1(pF)
1.2	4500	20	1.5	120
1.2	6000	27	1	82
1.2	9000	43	0.47	56
2.4	4500	51	1	56
2.4	6000	62	1	33
2.4	9000	82	0.47	27
4.7	4500	82	3.3	33
4.7	6000	100	1	15
4.7	9000	150	1	15

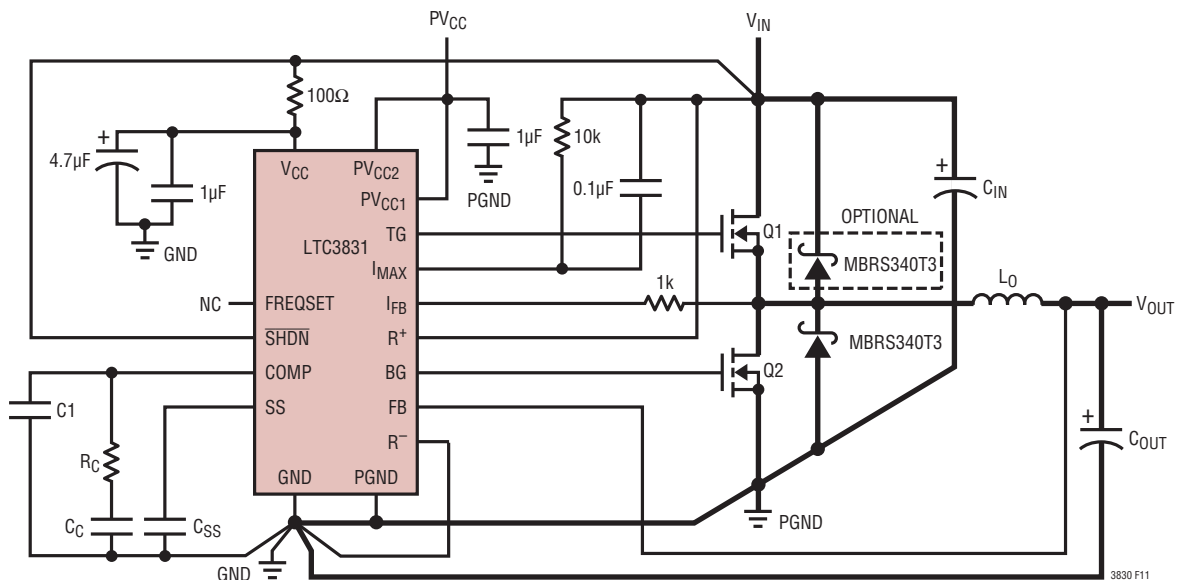

**Figure 10. Typical Schematic Showing Layout Considerations**

## APPLICATIONS INFORMATION

### LAYOUT CONSIDERATIONS

When laying out the printed circuit board, the following checklist should be used to ensure proper operation of the LTC3831. These items are also illustrated graphically in the layout diagram of Figure 10. The thicker lines show the high current paths. Note that at 5A current levels or above, current density in the PC board itself is a serious concern. Traces carrying high current should be as wide as possible. For example, a PCB fabricated with *2oz copper* requires a minimum trace width of *0.15" to carry 5A*.

1. In general, layout should begin with the location of the power devices. Be sure to orient the power circuitry so that a clean power flow path is achieved. Conductor widths should be maximized and lengths minimized. After you are satisfied with the power path, the control circuitry should be laid out. It is much easier to find routes for the relatively small traces in the control circuits than it is to find circuitous routes for high current paths.
2. *The GND and PGND pins should be shorted directly at the LTC3831.* This helps to minimize internal ground disturbances in the LTC3831 and prevents differences in ground potential from disrupting internal circuit operation. This connection should then tie into the ground plane at a single point, preferably at a fairly quiet point in the circuit such as *close to the output capacitors*. This is not always practical, however, due to physical constraints. Another reasonably good point to make this connection is between the output capacitors and the source connection of the bottom MOSFET Q2. Do not tie this single point ground in the trace run between the Q2 source and the input capacitor ground, as this area of the ground plane will be very noisy.
3. The small-signal resistors and capacitors for frequency compensation and soft-start should be located very close to their respective pins and the ground ends connected to the signal ground pin through a separate trace. Do not connect these parts to the ground plane!
4. The  $V_{CC}$ ,  $PV_{CC1}$  and  $PV_{CC2}$  decoupling capacitors should be as close to the LTC3831 as possible. The  $4.7\mu\text{F}$  and  $1\mu\text{F}$  bypass capacitors shown at  $V_{CC}$ ,  $PV_{CC1}$  and  $PV_{CC2}$  will help provide optimum regulation performance.
5. The (+) plate of  $C_{IN}$  should be connected as close as possible to the drain of the upper MOSFET, Q1. An additional  $1\mu\text{F}$  ceramic capacitor between  $V_{IN}$  and power ground is recommended.
6. The  $V_{FB}$  pin is very sensitive to pickup from the switching node. Care should be taken to isolate  $V_{FB}$  from possible capacitive coupling to the inductor switching signal.
7. In a typical SSTL application, if the  $R^+$  pin is to be connected to  $V_{DDQ}$ , which is also the main supply voltage for the switching regulator, do not connect  $R^+$  along the high current flow path; it should be connected to the SSTL interface supply output.  $R^-$  should be connected to the interface supply GND.
8. Kelvin sense  $I_{MAX}$  and  $I_{FB}$  at Q1's drain and source pins.

# PACKAGE DESCRIPTION

## GN Package 16-Lead Plastic SSOP (Narrow .150 Inch) (Reference LTC DWG # 05-08-1641)

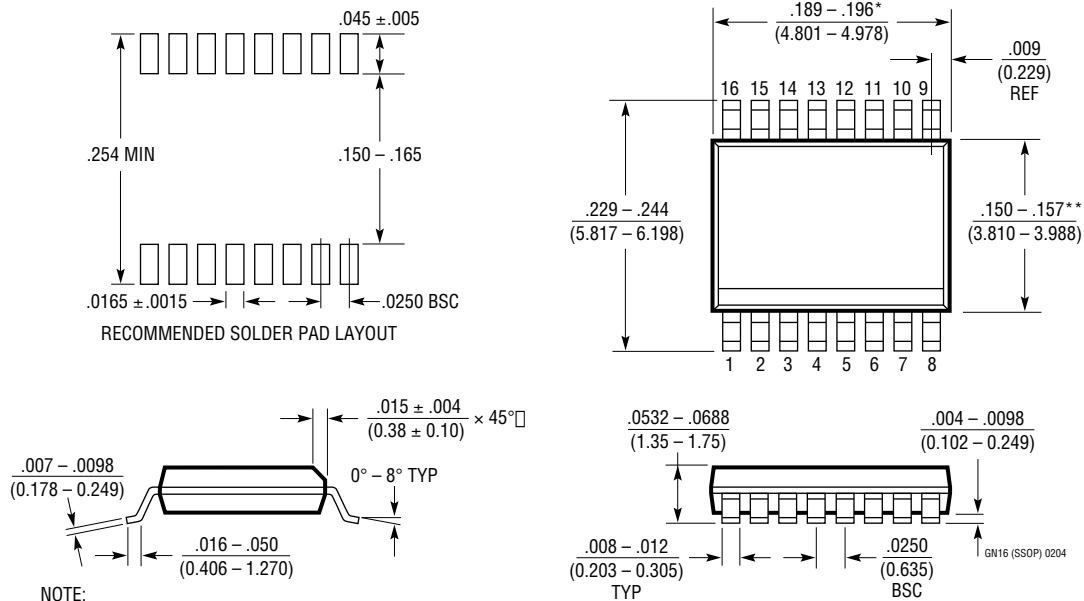

- NOTE:
1. CONTROLLING DIMENSION: INCHES
  2. DIMENSIONS ARE IN  $\frac{\text{INCHES}}{\text{(MILLIMETERS)}}$
  3. DRAWING NOT TO SCALE
- \*DIMENSION DOES NOT INCLUDE MOLD FLASH. MOLD FLASH SHALL NOT EXCEED  $0.006^*$  ( $0.152\text{mm}$ ) PER SIDE
- \*\*DIMENSION DOES NOT INCLUDE INTERLEAD FLASH. INTERLEAD FLASH SHALL NOT EXCEED  $0.010^*$  ( $0.254\text{mm}$ ) PER SIDE

## RELATED PARTS

PART NUMBER	DESCRIPTION	COMMENTS
LTC1530	High Power Synchronous Switching Regulator Controller	SO-8 with Current Limit. No R <sub>SENSE</sub> <sup>™</sup> required
LTC1628 Family	Dual High Efficiency 2-Phase Synchronous Step-Down Controllers	Constant Frequency, Standby 5V and 3.3V LDOs, $3.5 \leq V_{IN} \leq 36V$
LTC1702	Dual High Efficiency 2-Phase Synchronous Step-Down Controller	550kHz, 25MHz GBW Voltage Mode, $V_{IN} \leq 7V$ , No R <sub>SENSE</sub>
LTC1703	Dual 550kHz Synchronous 2-Phase Switching Regulator Controller with Mobile VID	LTC1702 with Mobile VID for Portable Systems
LTC1705	Dual 550kHz Synchronous 2-Phase Switching Regulator Controller with 5-Bit VID Plus LDO	Provides Core, I/O and CLK Supplies for Portable Systems
LTC1709 Family	2-Phase, 5-Bit Desktop VID Synchronous Step-Down Controllers	Current Mode, $V_{IN}$ to 36V, $I_{OUT}$ Up to 42A, Various VID Tables
LTC1736	Synchronous Step-Down Controller with 5-Bit Mobile VID control	Fault Protection, Power Good, 3.5V to 36V Input, Current Mode
LTC1753	5-Bit Desktop VID Programmable Synchronous Switching Regulator	1.3V to 3.5V Programmable Output Using Internal 5-Bit DAC
LTC1778	Wide Operating Range/Step-Down Controller, No R <sub>SENSE</sub>	$V_{IN}$ Up to 36V, Current Mode, Power Good
LTC1873	Dual Synchronous Switching Regulator with 5-Bit Desktop VID	1.3V to 3.5V Programmable Core Output Plus I/O Output
LTC1929	2-Phase, Synchronous High Efficiency Converter with Mobile VID	Current Mode Ensures Accurate Current Sensing $V_{IN}$ Up to 36V, $I_{OUT}$ Up to 40A
LTC3413	3A, Monolithic Synchronous Regulator for DDR/QDR Memory Termination	Low R <sub>DS(ON)</sub> Internal Switch: 85mΩ, ±3A Output Current (Sink and Source), $V_{OUT} = V_{REF}/2$
LTC3713	Low Input Voltage, High Power, No R <sub>SENSE</sub> , Step-Down Synchronous Controller	Minimum $V_{IN}$ : 1.5V, Uses Standard Logic-Level N-Channel MOSFETs
LTC3778	Wide Operating Range, No R <sub>SENSE</sub> , Step-Down Controller	$V_{IN}$ Up to 36V, Current Mode, Power Good, Stable with Ceramic C <sub>OUT</sub>
LTC3717	Wide $V_{IN}$ Step-Down Controller for DDR Memory Termination	Current Mode Operation, $V_{OUT} = 1/2 V_{IN}$ , $V_{OUT} (V_{TT})$ Tracks $V_{IN} (V_{DDQ})$ , No R <sub>SENSE</sub> , Symmetrical Sink and Source Output Current Limit
LTC3718	Bus Termination Supply for Low Voltage $V_{IN}$	$1.5V \leq V_{IN}$ , Generates 5V Gate Drive for Standard N-Ch MOSFETs, $2A \leq I_{OUT} \leq 25A$
LTC3832	High Power Synchronous Switching Regulator Controller	$V_{OUT}$ as low as 0.6V

No R<sub>SENSE</sub> is a trademark of Linear Technology Corporation.

## Looking for pricing, stock, or lifecycle information?

Click below to explore more details on WIN SOURCE:

⊖ [View LTC3831EGN#TRPBF on WIN SOURCE](#)

⊖ [Linear Technology](#) Information

## Optimize Your Supply Chain with WIN SOURCE Solutions

- ✓ Global Sourcing Solution
- ✓ Obsolete Management
- ✓ Cost Control Management
- ✓ Shortage Management
- ✓ Alternative Solution
- ✓ Excess Inventory Management