



**THE DATASHEET OF
LTC4414EMS8#PBF**



36V, Low Loss PowerPath™ Controller for Large PFETs

FEATURES

- Designed Specifically to Drive Large Q_G PFETs
- Very Low Loss Replacement for Power Supply OR'ing Diodes
- 3.5V to 36V AC/DC Adapter Voltage Range
- Minimal External Components
- Automatic Switching Between DC Sources
- Low Quiescent Current: 30 μ A
- 3V to 36V Battery Voltage Range
- Limited Reverse Battery Protection
- MOSFET Gate Protection Clamp
- Manual Control Input
- Space Saving 8-Lead MSOP Package

APPLICATIONS

- High Current Power Path Switch
- Industrial and Automotive Applications
- Uninterruptable Power Supplies
- Logic Controlled Power Switch
- Battery Backup Systems
- Emergency Systems with Battery Backups

LT, LT, LTC and LTM are registered trademarks of Linear Technology Corporation. PowerPath and ThinSOT are trademarks of Linear Technology Corporation. All other trademarks are the property of their respective owners.

DESCRIPTION

The LTC[®]4414 controls an external P-channel MOSFET to create a near ideal diode function for power switchover. This permits highly efficient OR'ing of multiple power sources for extended battery life and low self-heating. When conducting, the voltage drop across the MOSFET is typically 20mV. For applications with a wall adapter or other auxiliary power source, the load is automatically disconnected from the battery when the auxiliary source is connected. Two or more LTC4414s may be interconnected to allow switchover between multiple batteries or charging of multiple batteries from a single charger.

The wide supply operating range supports operation from one to eight Li-Ion cells in series. The low quiescent current (30 μ A typical) is independent of the load current. The gate driver includes an internal voltage clamp for MOSFET protection.

The STAT pin can be used to enable an auxiliary P-channel MOSFET power switch when an auxiliary supply is detected. This pin may also be used to indicate to a microcontroller that an auxiliary supply is connected. The control (CTL) input enables the user to force the primary MOSFET off and the STAT pin low.

The LTC4414 is available in a low profile 8-lead MSOP package.

TYPICAL APPLICATION

Automatic Switchover of Load Between a Battery and a Power Supply

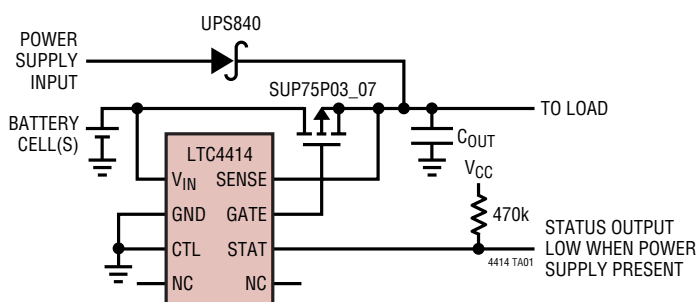

LTC4414 vs Schottky Diode Forward Voltage Drop

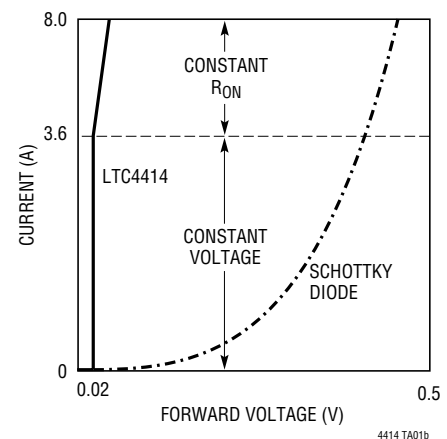

ABSOLUTE MAXIMUM RATINGS

(Note 1)

Supply Voltage (V_{IN})	-14V to 40V
Voltage from V_{IN} to SENSE	-40V to 40V
Input Voltage	
CTL	-0.3V to 40V
SENSE	-14V to 40V
Output Voltage	
GATE	-0.3V to the Higher of $V_{IN} + 0.3V$ or SENSE + 0.3V
STAT	-0.3V to 40V
Operating Ambient Temperature Range (Note 2)	
I Grade	-40°C to 125°C
E Grade	-40°C to 85°C
Operating Junction Temperature	-40°C to 125°C
Storage Temperature Range	-65°C to 150°C
Lead Temperature (Soldering, 10 sec)	300°C

PACKAGE/ORDER INFORMATION

<p style="text-align: center;">TOP VIEW</p> <p style="text-align: center;">MS8 PACKAGE 8-LEAD PLASTIC MSOP $T_{JMAX} = 125^{\circ}C$, $\theta_{JA} = 200^{\circ}C/W$</p>	
ORDER PART NUMBER	MS8 PART MARKING
LTC4414EMS8	LTBQF
LTC4414IMS8	LTBQG
Order Options Tape and Reel: Add #TR Lead Free: Add #PBF Lead Free Tape and Reel: Add #TRPBF Lead Free Part Marking: http://www.linear.com/leadfree/	

Consult LTC Marketing for parts specified with wider operating temperature ranges.

ELECTRICAL CHARACTERISTICS

The ● denotes specifications which apply over the full operating temperature range, unless otherwise noted specifications are at $T_A = 25^{\circ}C$, $V_{IN} = 12V$, CTL and GND = 0V. Current into a pin is positive and current out of a pin is negative. All voltages are referenced to GND, unless otherwise specified.

SYMBOL	PARAMETER	CONDITIONS	MIN	TYP	MAX	UNITS
V_{IN} , V_{SENSE}	Operating Supply Range	V_{IN} and/or V_{SENSE} Must Be in This Range for Proper Operation	● 3		36	V
I_{QFL}	Quiescent Supply Current at Low Supply While in Forward Regulation	$V_{IN} = 3.6V$. Measure Combined Current at V_{IN} and SENSE Pins Averaged with $V_{SENSE} = 3.5V$ and $V_{SENSE} = 3.6V$ (Note 3)	●	31	60	μA
I_{QFH}	Quiescent Supply Current at High Supply While in Forward Regulation	$V_{IN} = 36V$. Measure Combined Current at V_{IN} and SENSE Pins Averaged with $V_{SENSE} = 35.9V$ and $V_{SENSE} = 36V$ (Note 3)	●	36	61	μA
I_{QRL}	Quiescent Supply Current at Low Supply While in Reverse Turn-Off	$V_{IN} = 3.6V$, $V_{SENSE} = 3.7V$. Measure Combined Current of V_{IN} and SENSE Pins		21	30	μA
I_{QRH}	Quiescent Supply Current at High Supply While in Reverse Turn-Off	$V_{IN} = 35.9V$, $V_{SENSE} = 36V$. Measure Combined Current of V_{IN} and SENSE Pins		33	45	μA
I_{QCL}	Quiescent Supply Current at Low Supply with CTL Active	$V_{IN} = 3.6V$, $V_{CTL} = 1V$, $V_{IN} - V_{SENSE} = 0.9V$		14	20	μA
I_{QCH}	Quiescent Supply Current at High Supply with CTL Active	$V_{IN} = 36V$, $V_{CTL} = 1V$, $V_{IN} - V_{SENSE} = 0.9V$		26	35	μA
I_{LEAK}	V_{IN} and SENSE Pin Leakage Currents When Other Pin Supplies Power	$V_{IN} = 28V$, SENSE = 0V $V_{IN} = 14V$, SENSE = -14V $V_{IN} = 36V$, SENSE = 8V $V_{IN} = 0V$, SENSE = 28V $V_{IN} = -14V$, SENSE = 14V $V_{IN} = 8V$, SENSE = 36V	-10	-1	1	μA μA μA μA μA μA

PowerPath Controller

V_{FR}	PowerPath Switch Forward Regulation Voltage	$V_{IN} - V_{SENSE}$, $3V \leq V_{IN} \leq 36V$, $C_{GATE} = 3nF$	● 10		32	mV
V_{RTO}	PowerPath Switch Reverse Turn-Off Threshold Voltage	$V_{SENSE} - V_{IN}$, $3V \leq V_{IN} \leq 36V$, $C_{GATE} = 3nF$	● 10		32	mV

4414fc

ELECTRICAL CHARACTERISTICS The ● denotes specifications which apply over the full operating temperature range, unless otherwise noted specifications are at $T_A = 25^\circ\text{C}$, $V_{IN} = 12\text{V}$, CTL and GND = 0V. Current into a pin is positive and current out of a pin is negative. All voltages are referenced to GND, unless otherwise specified.

SYMBOL	PARAMETER	CONDITIONS	MIN	TYP	MAX	UNITS
GATE and STAT Outputs						
$I_{G(SRC)}$	GATE Active Forward Regulation Source Current	(Note 4)	-25		-7	μA
$I_{G(SNK)}$	GATE Active Forward Regulation Sink Current	(Note 4)	190		500	μA
$V_{G(ON)}$	GATE Clamp Voltage	Apply $I_{GATE} = 6\mu\text{A}$, $V_{IN} = 12\text{V}$, $V_{SENSE} = 11.9\text{V}$, Measure $V_{IN} - V_{GATE}$	8		9	V
$V_{G(OFF)}$	GATE Off Voltage	Apply $I_{GATE} = -30\mu\text{A}$, $V_{IN} = 12\text{V}$, $V_{SENSE} = 12.1\text{V}$, Measure $V_{SENSE} - V_{GATE}$		0.35	0.92	V
$t_{G(ON)}$	GATE Turn-On Time	$V_{GS} < -6\text{V}$, $C_{GATE} = 17\text{nF}$ (Note 5)			600	μs
$t_{G(OFF)}$	GATE Turn-Off Time	$V_{GS} > -1.5\text{V}$, $C_{GATE} = 17\text{nF}$ (Note 6)			20	μs
$I_{S(OFF)}$	STAT Off Current	$3\text{V} \leq V_{IN} \leq 36\text{V}$ (Note 7)	● -1	0	1	μA
$I_{S(SNK)}$	STAT Sink Current	$12\text{V} \leq V_{IN} \leq 36\text{V}$ (Note 7)	● 50		200	μA
$t_{S(ON)}$	STAT Turn-On Time	(Note 8)			8	μs
$t_{S(OFF)}$	STAT Turn-Off Time	(Note 8)			51	μs
CTL Input						
V_{IL}	CTL Input Low Voltage	$3\text{V} \leq V_{IN} \leq 36\text{V}$	● 0.35			V
V_{IH}	CTL Input High Voltage	$3\text{V} \leq V_{IN} \leq 36\text{V}$	●		0.9	V
I_{CTL}	CTL Input Pull-Down Current	$0.35\text{V} \leq V_{CTL} \leq 36\text{V}$		1	3.5	μA
H_{CTL}	CTL Hysteresis	$3\text{V} \leq V_{IN} \leq 36\text{V}$			170	mV

Note 1: Stresses beyond those listed under Absolute Maximum Ratings may cause permanent damage to the device. Exposure to any Absolute Maximum Rating condition for extended periods may affect device reliability and lifetime.

Note 2: The LTC4414E is guaranteed to meet performance specifications from 0°C to 85°C . Specifications over the -40°C to 85°C operating temperature range are assured by design, characterization and correlation with statistical process controls. The LTC4414I is guaranteed and tested over the -40° to 125° operating temperature range.

Note 3: This results in the same supply current as would be observed with an external P-channel MOSFET connected to the LTC4414 and operating in forward regulation.

Note 4: V_{IN} is held at 12V and GATE is forced to 9V. SENSE is set at 12V to measure the source current at GATE. SENSE is set at 11.9V to measure sink current at GATE.

Note 5: V_{IN} is held at 12V and SENSE is stepped from 12.2V to 11.8V to trigger the event. GATE voltage is initially $V_{G(OFF)}$.

Note 6: V_{IN} is held at 12V and SENSE is stepped from 11.8V to 12.2V to trigger the event. GATE voltage is initially internally clamped at $V_{G(ON)}$.

Note 7: STAT is forced to $V_{IN} - 1.5\text{V}$. SENSE is set at $V_{IN} - 0.1\text{V}$ to measure the off current at STAT. SENSE is set $V_{IN} + 0.1\text{V}$ to measure the sink current at STAT.

Note 8: STAT is forced to 9V and V_{IN} is held at 12V. SENSE is stepped from 11.8V to 12.2V to measure the STAT turn-on time defined when I_{STAT} reaches one half the measured $I_{S(SNK)}$. SENSE is stepped from 12.2V to 11.8V to measure the STAT turn-off time defined when I_{STAT} reaches one half the measured $I_{S(SNK)}$.

TYPICAL PERFORMANCE CHARACTERISTICS

V_{FR} vs Temperature and Supply Voltage

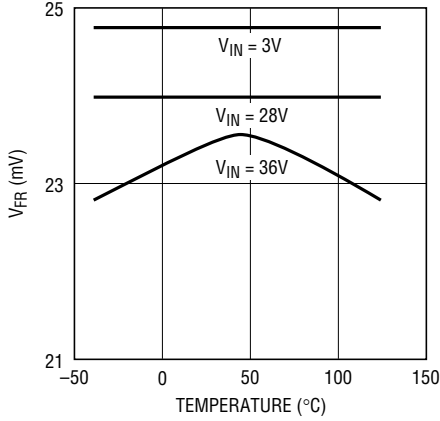

4414 G01

V_{RTO} vs Temperature and Supply Voltage

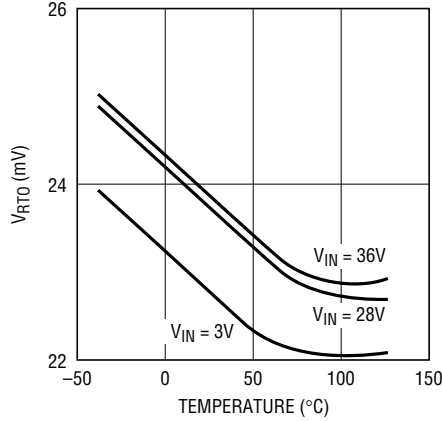

4414 G02

Normalized Quiescent Supply Current vs Temperature

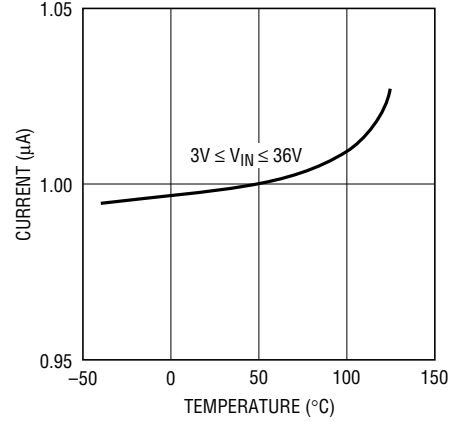

4414 G03

V_{IN} and SENSE Pin Leakage vs Temperature

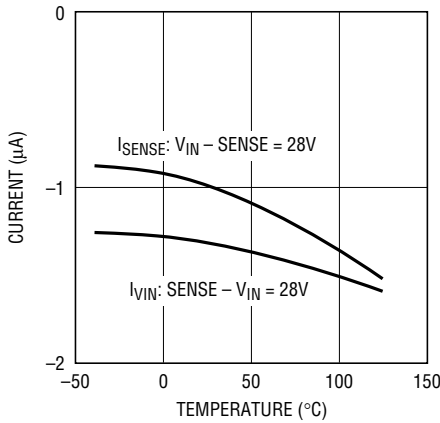

4414 G04

$V_{G(ON)}$ vs Temperature

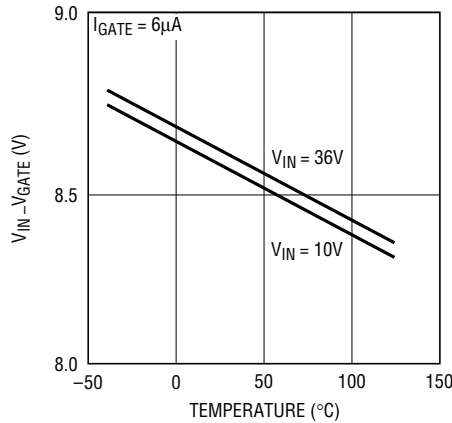

4414 G05

$V_{G(OFF)}$ vs Temperature and I_{GATE}

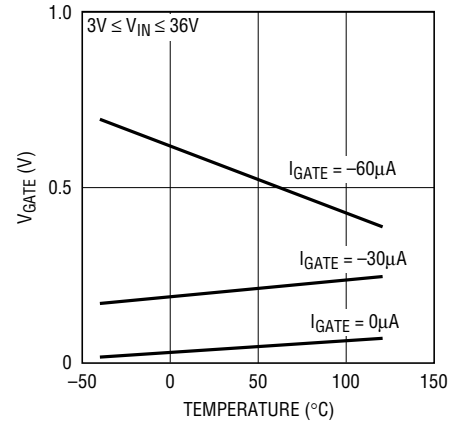

4414 G06

$t_{G(ON)}$ vs Temperature

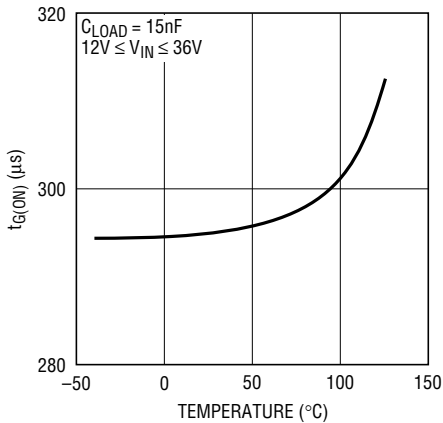

4414 G07

$t_{G(OFF)}$ vs Temperature

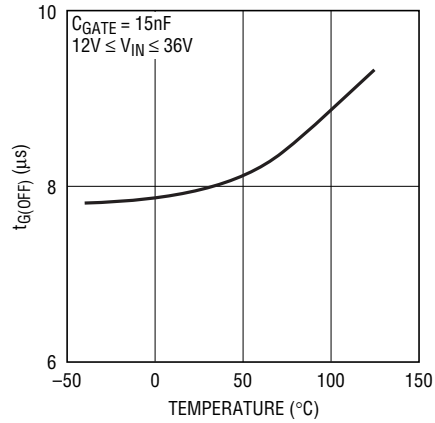

4414 G08

PIN FUNCTIONS

STAT (Pin 1): Open-Drain Output Status Pin. When the SENSE pin is pulled above the V_{IN} pin with an auxiliary power source by V_{RTO} or more, the reverse turn-off threshold (V_{RTO}) is reached. The STAT pin will then go from an open state to a current sink ($I_{S(SNK)}$). The STAT pin current sink can be used, along with an external resistor, to turn on an auxiliary P-channel power switch and/or signal the presence of an auxiliary power source to a microcontroller.

CTL (Pin 2): Digital Control Input. A logical high input (V_{IH}) on this pin forces the gate to source voltage of the primary P-channel MOSFET power switch to a small voltage ($V_{G\text{OFF}}$). This will turn the MOSFET off and no current will flow from the primary power input at V_{IN} if the MOSFET is configured so that the drain to source diode does not forward bias. A high input also forces the Open-Drain STAT pin ON. If the STAT pin is used to control an auxiliary P-channel power switch, then a second active source of power, such as an AC wall adaptor, will be connected to the load (see Applications Information). An internal current sink will pull the CTL pin voltage to ground (logical low) if the pin is open.

GND (Pin 3): Ground. Provides a power return for all the internal circuits.

SENSE (Pin 6): Power Sense Input Pin. Supplies power to the internal circuitry and is a voltage sense input to the internal analog controller (The other input to the controller is the V_{IN} pin). This input is usually supplied power from an auxiliary source such as an AC adapter or back-up battery which also supplies current to the load.

V_{IN} (Pin 7): Primary Input Supply Voltage. Supplies power to the internal circuitry and is one of two voltage sense inputs to the internal analog controller (The other input to the controller is the SENSE pin). This input is usually supplied power from a battery or other power source which supplies current to the load. This pin can be bypassed to ground with a capacitor in the range of 0.1 μF to 10 μF if needed to suppress load transients.

GATE (Pin 8): Primary P-Channel MOSFET Power Switch Gate Drive Pin. This pin is directed by the power controller to maintain a forward regulation voltage (V_{FR}) of 20mV between the V_{IN} and SENSE pins when an auxiliary power source is not present. When an auxiliary power source is connected, the GATE pin will pull up to the SENSE pin voltage, turning off the primary P-channel power switch.

BLOCK DIAGRAM

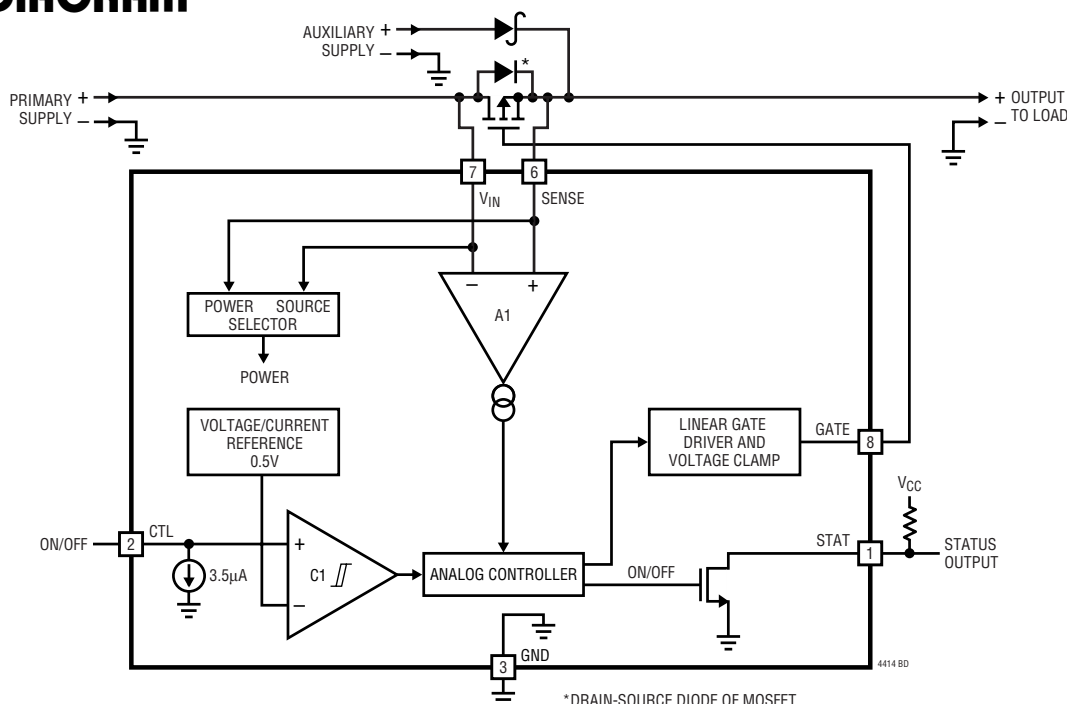

*DRAIN-SOURCE DIODE OF MOSFET

4414fc

OPERATION

Operation can best be understood by referring to the Block Diagram, which illustrates the internal circuit blocks along with the few external components, and the graph that accompanies the Typical Application drawing on the front page of the data sheet. The terms primary and auxiliary are arbitrary and may be changed to suit the application. Operation begins when either or both power sources are applied and the CTL control pin is below the input low voltage of 0.35V (V_{IL}). If only the primary supply is present, the Power Source Selector will power the LTC4414 from the V_{IN} pin. Amplifier A1 will deliver a current to the Analog Controller block that is proportional to the voltage difference in the V_{IN} and SENSE pins. While the voltage on SENSE is lower than $V_{IN} - 20\text{mV}$ (V_{FR}), the Analog Controller will instruct the Linear Gate Driver and Voltage Clamp block to pull down the GATE pin voltage and turn on the external P-channel MOSFET. The dynamic pull-down current of $300\mu\text{A}$ ($I_{G(SNK)}$) stops when the GATE voltage reaches ground or the gate clamp voltage. The gate clamp voltage is 8.5V ($V_{G(ON)}$) below the higher of V_{IN} or V_{SENSE} . As the SENSE voltage pulls up to $V_{IN} - 20\text{mV}$, the LTC4414 will regulate the GATE voltage to maintain a 20mV difference between V_{IN} and V_{SENSE} which is also the V_{DS} of the MOSFET. The system is now in the forward regulation mode and the load will be powered from the primary supply. As the load current varies, the GATE voltage will be controlled to maintain the 20mV difference. If the load current exceeds the P-channel MOSFET's ability to deliver the current with a 20mV V_{DS} the GATE voltage will clamp, the MOSFET will behave as a fixed resistor and the forward voltage will increase slightly. While the MOSFET is on the STAT pin is an open circuit.

When an auxiliary supply is applied, the SENSE pin will be pulled higher than the V_{IN} pin through the external diode.

The Power Source Selector will power the LTC4414 from the SENSE pin. As the SENSE voltage pulls above $V_{IN} - 20\text{mV}$, the Analog Controller will instruct the Linear Gate Driver and Voltage Clamp block to pull the GATE voltage up to turn off the P-channel MOSFET. When the voltage on SENSE is higher than $V_{IN} + 20\text{mV}$ (V_{RTO}), the Analog Controller will instruct the Linear Gate Driver and Voltage Clamp block to rapidly pull the GATE pin voltage to the SENSE pin voltage. This action will quickly finish turning off the external P-channel MOSFET if it hasn't already turned completely off. For a clean transition, the reverse turn-off threshold has hysteresis to prevent uncertainty. The system is now in the reverse turn-off mode. Power to the load is being delivered through the external diode and no current is drawn from the primary supply. The external diode provides protection in case the auxiliary supply is below the primary supply, sinks current to ground or is connected reverse polarity. During the reverse turn-off mode of operation the STAT pin will sink a current ($I_{S(SNK)}$) if connected. Note that the external MOSFET is wired so that the drain to source diode will momentarily forward bias when power is first applied to V_{IN} and will become reverse biased when an auxiliary supply is applied.

When the CTL (control) input is asserted high, the external MOSFET will have its gate to source voltage forced to a small voltage $V_{G(OFF)}$ and the STAT pin will sink a minimum of $50\mu\text{A}$ of current if connected. This feature is useful to allow control input switching of the load between two power sources as shown in Figure 3 or as a switchable high side driver as shown in Figure 7. A $3.5\mu\text{A}$ internal pull-down current (I_{CTL}) on the CTL pin will insure a low level input if the pin should become open.

APPLICATIONS INFORMATION

Introduction

The system designer will find the LTC4414 useful in a variety of cost and space sensitive power control applications that include low loss diode OR'ing, fully automatic switchover from a primary to an auxiliary source of power, microcontroller controlled switchover from a primary to an auxiliary source of power, charging of multiple batteries from a single charger and high side power switching.

External P-Channel MOSFET Transistor Selection

Important parameters for the selection of MOSFETs are the maximum drain-source voltage $V_{DS(MAX)}$, threshold voltage $V_{GS(VT)}$ and on-resistance $R_{DS(ON)}$.

The maximum allowable drain-source voltage, $V_{DS(MAX)}$, must be high enough to withstand the maximum drain-source voltage seen in the application.

The maximum gate drive voltage for the primary MOSFET is set by the smaller of the V_{IN} supply voltage or the internal clamping voltage $V_{G(ON)}$. A logic level MOSFET is commonly used, but if a low supply voltage limits the gate voltage, a sub-logic level threshold MOSFET should be considered. The maximum gate drive voltage for the auxiliary MOSFET, if used, is determined by the external resistor connected to the STAT pin.

As a general rule, select a MOSFET with a low enough $R_{DS(ON)}$ to obtain the desired V_{DS} while operating at full load current and an achievable V_{GS} . The MOSFET normally operates in the linear region and acts like a voltage controlled resistor. If the MOSFET is grossly undersized, it can enter the saturation region and a large V_{DS} may result. However, the drain-source diode of the MOSFET, if forward biased, will limit V_{DS} . A large V_{DS} , combined with the load current, will likely result in excessively high MOSFET power dissipation. Keep in mind that the LTC4414 will regulate the forward voltage drop across the primary MOSFET at 20mV if $R_{DS(ON)}$ is low enough. The required $R_{DS(ON)}$ can be calculated by dividing 0.02V by the load current in amps. Achieving forward regulation will minimize power loss and heat dissipation, but it is not a necessity. If a forward voltage drop of more than 20mV is acceptable then a smaller MOSFET can be used, but must be sized compatible with the higher power dissipation.

Care should be taken to ensure that the power dissipated is never allowed to rise above the manufacturer's recommended maximum level. The auxiliary MOSFET power switch, if used, has similar considerations, but its V_{GS} can be tailored by resistor selection. When choosing the resistor value consider the full range of STAT pin current ($I_{S(SNK)}$) that may flow through it.

V_{IN} and SENSE Pin Bypass Capacitors

Many types of capacitors, ranging from 0.1 μ F to 10 μ F and located close to the LTC4414, will provide adequate V_{IN} bypassing if needed. Voltage droop can occur at the load during a supply switchover because some time is required to turn on the MOSFET power switch. Factors that determine the magnitude of the voltage droop include the supply rise and fall times, the MOSFET's characteristics, the value of C_{OUT} and the load current. Droop can be made insignificant by the proper choice of C_{OUT} , since the droop is inversely proportional to the capacitance. Bypass capacitance for the load also depends on the application's dynamic load requirements and typically ranges from 1 μ F to 47 μ F. In all cases, the maximum droop is limited to the drain source diode forward drop inside the MOSFET.

Caution must be exercised when using multilayer ceramic capacitors. Because of the self resonance and high Q characteristics of some types of ceramic capacitors, high voltage transients can be generated under some start-up conditions such as connecting a supply input to a hot power source. To reduce the Q and prevent these transients from exceeding the LTC4414's absolute maximum voltage rating, the capacitor's ESR can be increased by adding up to several ohms of resistance in series with the ceramic capacitor. Refer to Application Note 88.

The selected capacitance value and capacitor's ESR can be verified by observing V_{IN} and SENSE for acceptable voltage transitions during dynamic conditions over the full load current range. This should be checked with each power source as well. Ringing may indicate an incorrect bypass capacitor value and/or too low an ESR.

V_{IN} and SENSE Pin Usage

Since the analog controller's thresholds are small (± 20 mV), the V_{IN} and SENSE pin connections should be made in a

APPLICATIONS INFORMATION

way to avoid unwanted $I \cdot R$ drops in the power path. Both pins are protected from negative voltages.

GATE Pin Usage

The GATE pin controls the external P-channel MOSFET connected between the V_{IN} and SENSE pins when the load current is supplied by the power source at V_{IN} . In this mode of operation, the internal current source, which is responsible for pulling the GATE pin up, is limited to a few microamps ($I_{G(SRC)}$). If external opposing leakage currents exceed this, the GATE pin voltage will reach the clamp voltage (V_{GON}) and V_{DS} will be smaller. The internal current sink, which is responsible for pulling the GATE pin down, has a higher current capability ($I_{G(SNK)}$). With an auxiliary supply input pulling up on the SENSE pin and exceeding the V_{IN} pin voltage by 20mV (V_{RTO}), the device enters the reverse turn-off mode and a much stronger current source is available to oppose external leakage currents and turn off the MOSFET ($V_{G OFF}$).

While in forward regulation, if the on resistance of the MOSFET is too high to maintain forward regulation, the GATE pin will maximize the MOSFET's V_{GS} to that of the clamp voltage (V_{GON}). The clamping action takes place between V_{IN} and the GATE pin.

STAT Pin Usage

During normal operation, the open-drain STAT pin can be biased at any voltage between ground and 36V regardless of the supply voltage to the LTC4414. It is usually connected to a resistor whose other end connects to a voltage source. In the forward regulation mode, the STAT pin will be open ($I_{S(OFF)}$). When a wall adaptor input or other auxiliary supply is connected to that input, and the voltage on SENSE is higher than $V_{IN} + 20mV$ (V_{RTO}), the system is in the reverse turn-off mode. During this mode of operation the STAT pin will sink at least 50 μ A of current ($I_{S(SNK)}$). This will result in a voltage change across the resistor, depending on the resistance, which is useful to turn on an auxiliary P-channel MOSFET or signal to a microcontroller that an auxiliary power source is connected. External leakage currents, if significant, should be accounted for when determining the voltage across the resistor when the STAT pin is either on or off.

CTL Pin Usage

This is a digital control input pin with low threshold voltages (V_{IL}, V_{IH}) for use with logic powered from as little as 1V. During normal operation, the CTL pin can be biased at any voltage between ground and 36V, regardless of the supply voltage to the LTC4414. A logical high input on this pin forces the gate to source voltage of the primary P-channel MOSFET power switch to a small voltage ($V_{G OFF}$). This will turn the MOSFET off and no current will flow from the primary power input at V_{IN} if the MOSFET is configured so that the drain to source diode is not forward biased. The high input also forces the STAT pin to sink at least 50 μ A of current ($I_{S(SNK)}$). See the Typical Applications for various examples on using the STAT pin. A 3.5 μ A internal pull-down current (I_{CTL}) on the CTL pin will insure a logical low level input if the pin should be open.

Protection

Most of the application circuits shown provide some protection against supply faults such as shorted, low or reversed supply inputs. The fault protection does not protect shorted supplies but can isolate other supplies and the load from faults. A necessary condition of this protection is for all components to have sufficient breakdown voltages. In some cases, if protection of the auxiliary input (sometimes referred to as the wall adapter input) is not required, then the series diode or MOSFET may be eliminated.

Internal protection for the LTC4414 is provided to prevent damaging pin currents and excessive internal self heating during a fault condition. These fault conditions can be a result of V_{IN} , SENSE, GATE or CTL pins shorted to ground or to a power source that is within the pin's absolute maximum voltage limits. Both the V_{IN} and SENSE pins are capable of being taken significantly below ground without current drain or damage to the IC (see Absolute Maximum Voltage Limits). This feature allows for limited reverse-battery condition without current drain or damage. This internal protection is not designed to prevent overcurrent or overheating of external components.

TYPICAL APPLICATIONS

Automatic PowerPath Control

The applications shown in Figures 1 and 2 and the typical application shown on the first page of this data sheet are automatic ideal diode controllers that require no assistance from a microcontroller. Each of these will automatically connect the higher supply voltage, after accounting for certain diode forward voltage drops, to the load with application of the higher supply voltage. These circuits are not recommended for load sharing.

The typical application shown on the first page on this data sheet illustrates an application circuit for automatic switchover of a load between a battery and a wall adapter or other power input. With application of the battery, the load will initially be pulled up by the drain-source diode of the P-channel MOSFET. As the LTC4414 comes into action, it will control the MOSFET's gate to turn it on and reduce the MOSFET's voltage drop from a diode drop to 20mV. The system is now in the low loss forward regulation mode. Should the wall adapter input be applied, the Schottky diode will pull up the SENSE pin, connected to the load, above the battery voltage and the LTC4414 will turn the MOSFET off. The STAT pin will then sink current indicating an auxiliary input is connected. The battery is now supplying no load current and all the load current flows through the Schottky diode. A silicon diode could be used instead of the Schottky, but will result in higher power dissipation and heating due to the higher forward voltage drop.

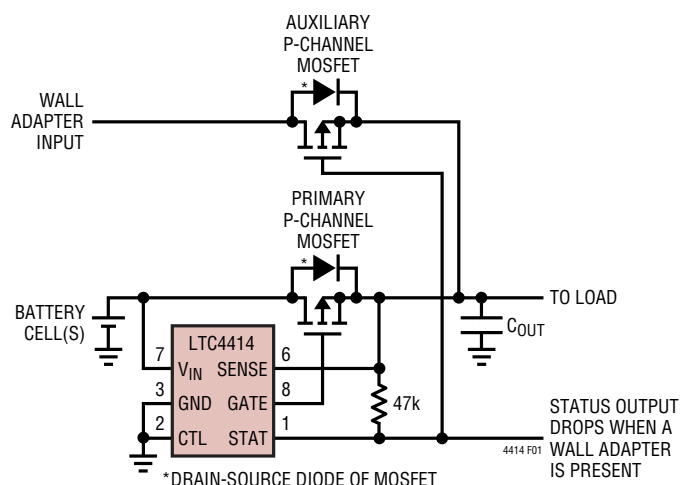

Figure 1. Automatic Switchover of Load Between a Battery and a Wall Adapter with Auxiliary P-Channel MOSFET for Lowest Loss

Figure 1 illustrates an application circuit for automatic switchover of load between a battery and a wall adapter that features lowest power loss. Operation is similar to the Typical Application on the front page except that an auxiliary P-channel MOSFET replaces the diode. The STAT pin is used to turn on the MOSFET once the SENSE pin voltage exceeds the battery voltage by 20mV. When the wall adapter input is applied, the drain-source diode of the auxiliary MOSFET will turn on first to pull up the SENSE pin and turn off the primary MOSFET followed by turning on of the auxiliary MOSFET. Once the auxiliary MOSFET has turned on the voltage drop across it can be very low depending on the MOSFET's characteristics.

Figure 2 illustrates an application circuit for the automatic switchover of a load between a battery and a wall adapter in the comparator mode. It also shows how a battery charger can be connected. This circuit differs from Figure 1 in the way the SENSE pin is connected. The SENSE pin is connected directly to the auxiliary power input and not the load. This change forces the LTC4414's control circuitry to operate in an open-loop comparator mode. While the battery supplies the system, the GATE pin voltage will be forced to its lowest clamped potential, instead of being regulated to maintain a 20mV drop across the MOSFET. This has the advantages of minimizing power loss in the MOSFET by minimizing its R_{ON} and not having the influence of a linear control loop's dynamics. A possible disadvantage is if the auxiliary input ramps up slow enough the load voltage will initially droop before rising.

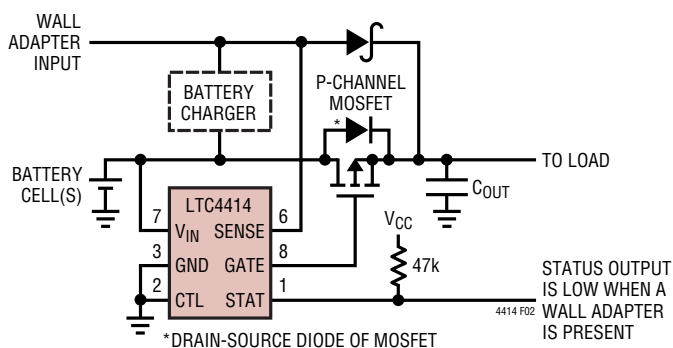

Figure 2. Automatic Switchover of Load Between a Battery and a Wall Adapter in Comparator Mode

TYPICAL APPLICATIONS

This is due to the SENSE pin voltage rising above the battery voltage and turning off the MOSFET before the Schottky diode turns on. The factors that determine the magnitude of the voltage droop are the auxiliary input rise time, the type of diode used, the value of C_{OUT} and the load current.

Ideal Diode Control with a Microcontroller

Figure 3 illustrates an application circuit for microcontroller monitoring and control of two power sources. The microcontroller's analog inputs, perhaps with the aid of a resistor voltage divider, monitors each supply input and commands the LTC4414 through the CTL input. Back-to-back MOSFETs are used so that the drain-source diode will not power the load when the MOSFET is turned off (dual MOSFETs in one package are commercially available).

With a logical low input on the CTL pin, the primary input supplies power to the load regardless of the auxiliary voltage. When CTL is switched high, the auxiliary input will power the load whether or not it is higher or lower than the primary power voltage. Once the auxiliary is on, the primary power can be removed and the auxiliary will

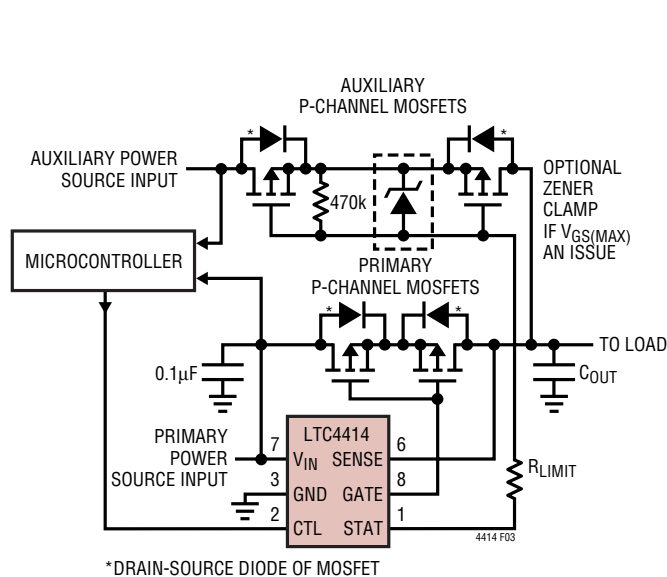

Figure 3. Microcontroller Monitoring and Control of Two Power Sources

continue to power the load. Only when the primary voltage is higher than the auxiliary voltage will taking CTL low switch back to the primary power, otherwise the auxiliary stays connected. When the primary power is disconnected and V_{IN} falls below V_{LOAD} , it will turn on the auxiliary MOSFET if CTL is low, but V_{LOAD} must stay up long enough for the MOSFET to turn on. At a minimum, C_{OUT} capacitance must be sized to hold up V_{LOAD} until the transition between the sets of MOSFETs is complete. Sufficient capacitance on the load and low or no capacitance on V_{IN} will help ensure this. If desired, this can be avoided by use of a capacitor on V_{IN} to ensure that V_{IN} falls more slowly than V_{LOAD} . This circuit is not recommended for load sharing.

High Current Power Supply Load Sharing

Figure 4 illustrates an application circuit for dual identical power supply load sharing. The load will then be shared between the two power supplies according to their source impedances. The STAT pins provide information as to which input is supplying the load current. This concept can be expanded to more power inputs.

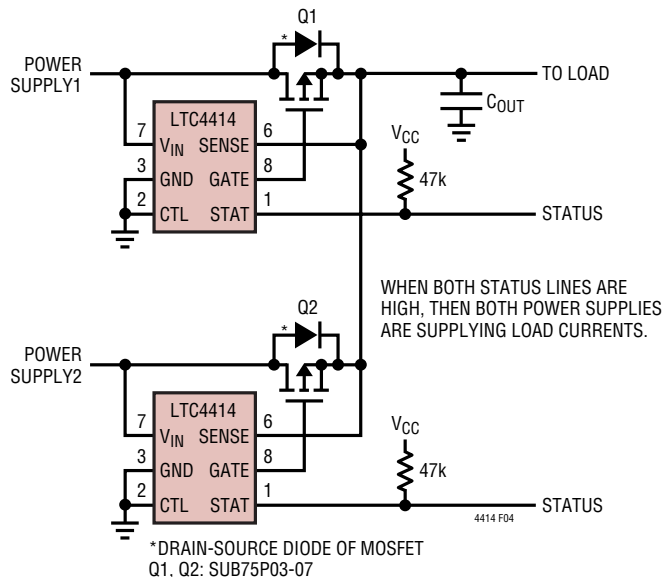

Figure 4. High Current Dual Power Supply Load Sharing

TYPICAL APPLICATIONS

Battery Load Sharing

Figure 5 illustrates an application circuit for dual battery load sharing with automatic switchover of load from batteries to wall adapter. Whichever battery can supply the higher voltage will provide the load current until it is discharged to the voltage of the other battery. The load will then be shared between the two batteries according to the capacity of each battery. The higher capacity battery will provide proportionally higher current to the load. When a wall adapter input is applied, both MOSFETs will turn off and no load current will be drawn from the batteries. The STAT pins provide information as to which input is supplying the load current. This concept can be expanded to more power inputs.

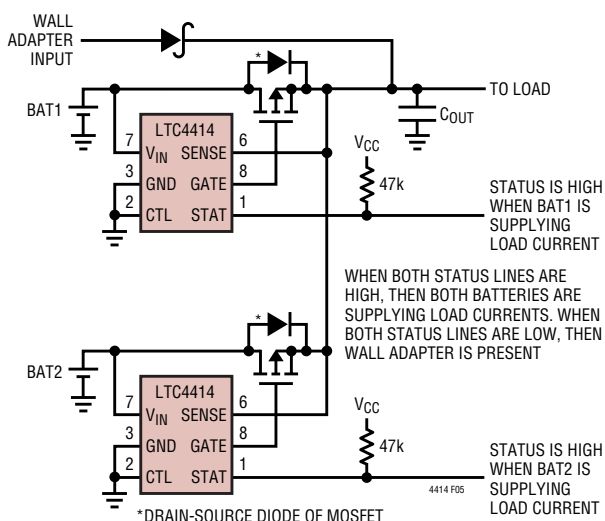

Figure 5. Dual Battery Load Sharing with Automatic Switchover of Load from Batteries to Wall Adapter

Multiple Battery Charging

Figure 6 illustrates an application circuit for automatic dual battery charging from a single charger. Whichever battery has the lower voltage will receive the charging current until both battery voltages are equal, then both will be charged. When both are charged simultaneously, the higher capacity battery will get proportionally higher current from the charger. For Li-Ion batteries, both batteries will achieve the float voltage minus the forward regulation voltage of 20mV. This concept can apply to more than two batteries. The STAT pins provide information as to which batteries are being charged. For intelligent control, the

CTL pin input can be used with a microcontroller and back-to-back MOSFETs as shown in Figure 4. This allows complete control for disconnection of the charger from either battery.

High Side Power Switch

Figure 7 illustrates an application circuit for a logic controlled high side power switch. When the CTL pin is a logical low, the LTC4414 will turn on the MOSFET. Because the SENSE pin is grounded, the LTC4414 will apply maximum clamped gate drive voltage to the MOSFET. When the CTL pin is a logical high, the LTC4414 will turn off the MOSFET by pulling its gate voltage up to the supply input voltage and thus deny power to the load. The MOSFET is connected with its source connected to the power source. This disables the drain-source diode from supplying voltage to the load when the MOSFET is off. Note that if the load is powered from another source, then the drain-source diode can forward bias and deliver current to the power supply connected to the V_{IN} pin.

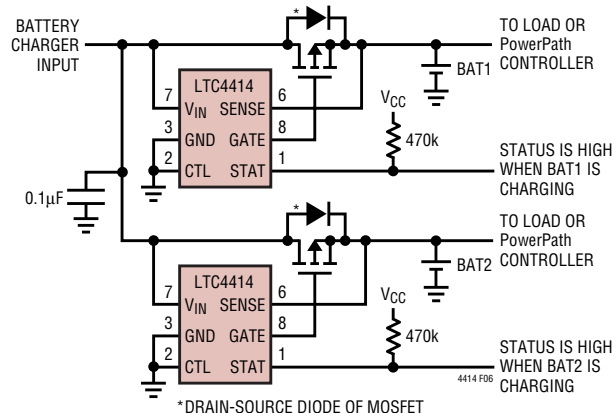

Figure 6. Automatic Dual Battery Charging from Single Charging Source

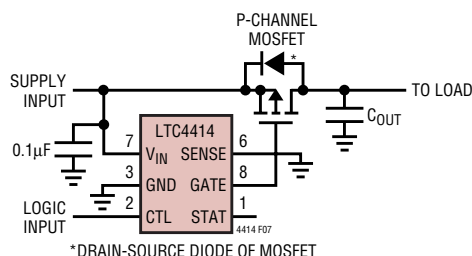
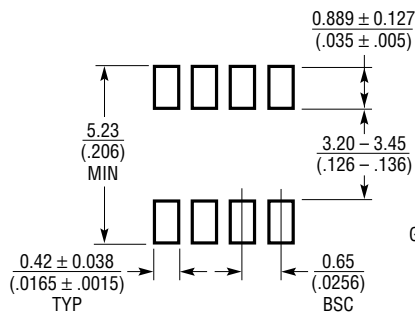

Figure 7. Logic Controlled High Side Power Switch

PACKAGE DESCRIPTION

MS8 Package
8-Lead Plastic MSOP
 (Reference LTC DWG # 05-08-1660)



RECOMMENDED SOLDER PAD LAYOUT

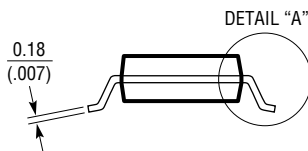
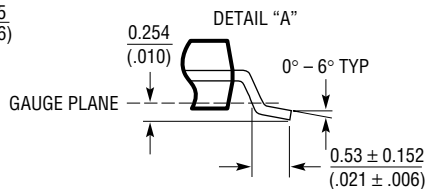

NOTE:

1. DIMENSIONS IN MILLIMETER/(INCH)
2. DRAWING NOT TO SCALE
3. DIMENSION DOES NOT INCLUDE MOLD FLASH, PROTRUSIONS OR GATE BURRS.
MOLD FLASH, PROTRUSIONS OR GATE BURRS SHALL NOT EXCEED 0.152mm (.006") PER SIDE
4. DIMENSION DOES NOT INCLUDE INTERLEAD FLASH OR PROTRUSIONS.
INTERLEAD FLASH OR PROTRUSIONS SHALL NOT EXCEED 0.152mm (.006") PER SIDE
5. LEAD COPLANARITY (BOTTOM OF LEADS AFTER FORMING) SHALL BE 0.102mm (.004") MAX

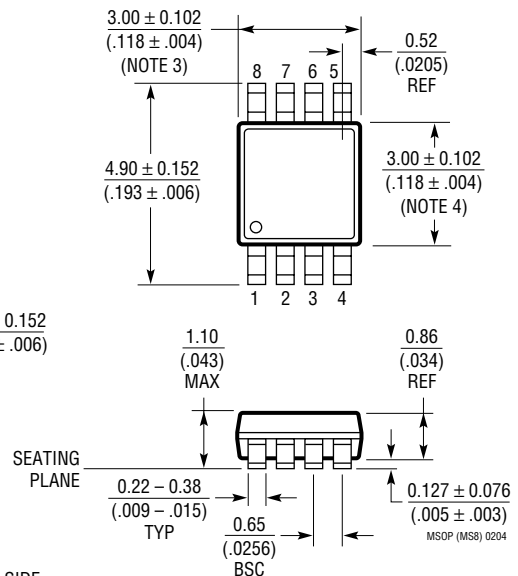

RELATED PARTS

PART NUMBER	DESCRIPTION	COMMENTS
LTC1473	Dual PowerPath Switch Driver	Switches and Isolates Sources Up to 30V
LTC1479	PowerPath Controller for Dual Battery Systems	Complete PowerPath Management for Two Batteries; DC Power Source, Charger and Backup
LTC1558/LTC1559	Back-Up Battery Controller with Programmable Output	Adjustable Backup Voltage from 1.2V NiCd Button Cell, Includes Boost Converter
LT [®] 1579	300mA Dual Input Smart Battery Back-Up Regulator	Maintains Output Regulation with Dual Inputs, 0.4V Dropout at 300mA
LTC1733/LTC1734	Monolithic Linear Li-Ion Chargers	Thermal Regulation, No External MOSFET/Sense Resistor
LTC1998	2.5µA, 1% Accurate Programmable Battery Detector	Adjustable Trip Voltage/Hysteresis, ThinSOT
LTC4055	USB Power Controller and Li-Ion Linear Charger	Automatic Battery Switchover, Thermal Regulation, Accepts Wall Adapter and USB Power, 4mm × 4mm QFN
LTC4354	Negative Voltage Diode-OR Controller and Monitor	Replaces Power Schottky Diodes; 80V Operation
LTC4410	USB Power Manager in ThinSOT [™]	Enables Simultaneous Battery Charging and Operation of USB Component Peripheral Devices
LTC4411	SOT-23 Ideal Diode	2.6A Forward Current, 28mV Regulated Forward Voltage
LTC4412HV	36V, Low Loss PowerPath Controller in MSOP	-40°C to -125°C Operation; Automatic Switch Between DC Sources
LTC4413	Dual 2.6A, 2.5V to 5.5V Ideal Diodes in 3mm × 3mm DFN	100mΩ ON Resistance, 1µA Reverse Leakage Current, 28mV Regulated Forward Voltage

Looking for pricing, stock, or lifecycle information?

Click below to explore more details on WIN SOURCE:

 [View LTC4414EMS8#PBF on WIN SOURCE](#)

 [Linear Technology](#) Information

Optimize Your Supply Chain with WIN SOURCE Solutions

-  Global Sourcing Solution
-  Obsolete Management
-  Cost Control Management
-  Shortage Management
-  Alternative Solution
-  Excess Inventory Management