



**THE DATASHEET OF  
LTC6420CUDC-20#PBF**



# Dual Matched 1.8GHz Differential Amplifiers/ADC Drivers

## FEATURES

- Matched Gain  $\pm 0.1\text{dB}$
- Matched Phase  $\pm 0.1^\circ$  at 100MHz
- Channel Separation 80dB at 100MHz
- 1.8GHz  $-3\text{dB}$  Bandwidth; Fixed Gain of 10V/V (20dB)
- IMD3 =  $-84\text{dBc}$  at 100MHz, 2V<sub>P-P</sub>
- Equivalent OIP3 = 46dBm at 100MHz
- 1nV/ $\sqrt{\text{Hz}}$  Internal Op Amp Noise
- 6.2dB Noise Figure
- Differential Inputs and Outputs
- Rail-to-Rail Output Swing
- 80mA Supply Current (240mW) per Amplifier
- 1.1V to 1.6V Output Common Mode Voltage, Adjustable
- DC- or AC-Coupled Operation
- 20-Lead 3mm  $\times$  4mm  $\times$  0.75mm QFN Package

## APPLICATIONS

- Differential ADC Driver
- Single Ended to Differential Conversion
- IF Sampling (Diversity) Receivers
- Broadband I/Q Amplifiers
- Satellite Communications

## DESCRIPTION

The LTC<sup>®</sup>6420-20 is a dual high-speed differential amplifier targeted at processing signals from DC to 300MHz. The part has been specifically designed to drive 12-, 14- and 16-bit ADCs with low noise and low distortion, but can also be used as a general-purpose broadband gain block.

The LTC6420-20 is easy to use, with minimal support circuitry required. The output common mode voltage is set using an external pin, independent of the inputs, which eliminates the need for transformers or AC-coupling capacitors in many applications. The gain is internally fixed at 20dB (10V/V).

The LTC6420-20 saves space and power compared to alternative solutions using IF gain blocks and transformers. The LTC6420-20 is packaged in a compact 20-lead 3mm  $\times$  4mm QFN package and operates over the  $-40^\circ\text{C}$  to  $85^\circ\text{C}$  temperature range.

LT, LTC, LTM, Linear Technology and the Linear logo are registered trademarks of Linear Technology Corporation. All other trademarks are the property of their respective owners.

## TYPICAL APPLICATION

Matched Dual Amplifier with Output Common Mode Biasing

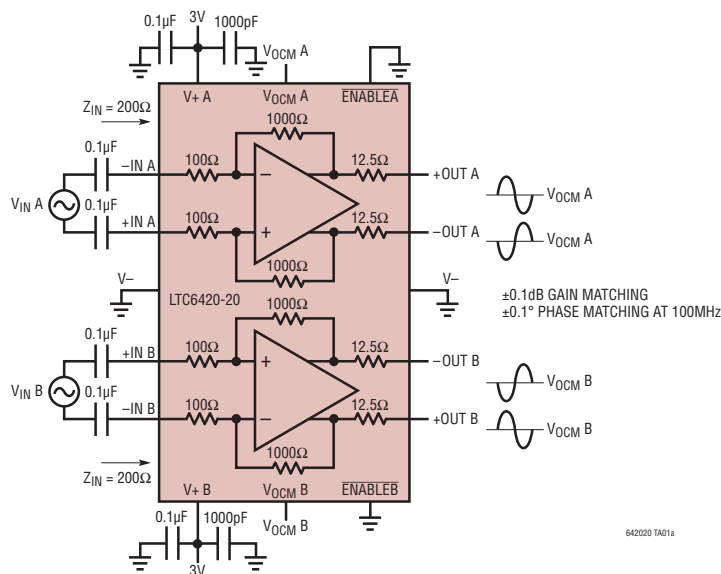

Distribution of Gain Match

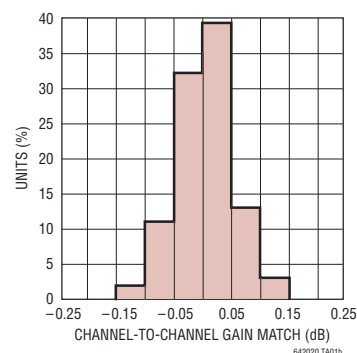

# LTC6420-20

## ABSOLUTE MAXIMUM RATINGS

(Note 1)

Supply Voltage ( $V^+ - V^-$ ) .....	3.6V
Input Current (Note 2).....	$\pm 10\text{mA}$
Operating Temperature Range (Note 3)...	$-40^\circ\text{C}$ to $85^\circ\text{C}$
Specified Temperature Range (Note 4) ....	$-40^\circ\text{C}$ to $85^\circ\text{C}$
Storage Temperature Range.....	$-65^\circ\text{C}$ to $150^\circ\text{C}$
Maximum Junction Temperature.....	$150^\circ\text{C}$
Output Short Circuit Duration.....	Indefinite

## PIN CONFIGURATION

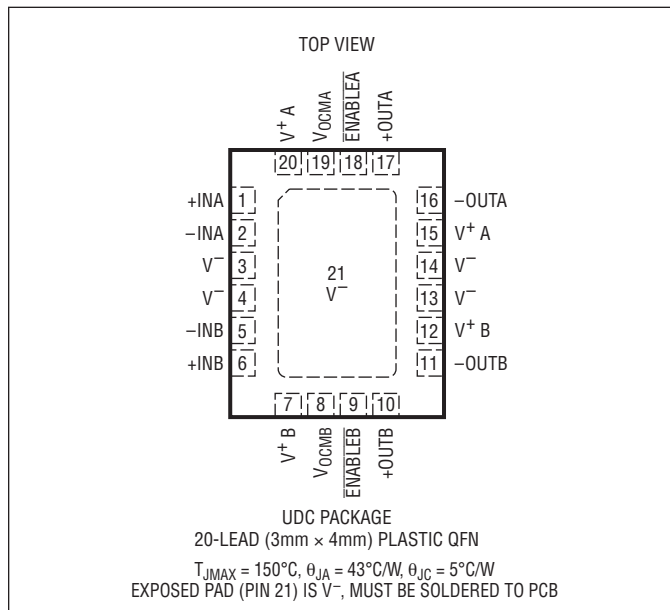

## ORDER INFORMATION

LEAD FREE FINISH	TAPE AND REEL	PART MARKING*	PACKAGE DESCRIPTION	SPECIFIED TEMPERATURE RANGE
LTC6420CUDC-20#PBF	LTC6420CUDC-20#TRPBF	LDDM	20-Lead (3mm x 4mm) Plastic QFN	$0^\circ\text{C}$ to $70^\circ\text{C}$
LTC6420IUDC-20#PBF	LTC6420IUDC-20#TRPBF	LDDM	20-Lead (3mm x 4mm) Plastic QFN	$-40^\circ\text{C}$ to $85^\circ\text{C}$

Consult LTC Marketing for parts specified with wider operating temperature ranges. \*The temperature grade is identified by a label on the shipping container. Consult LTC Marketing for information on non-standard lead based finish parts.

For more information on lead free part marking, go to: <http://www.linear.com/leadfree/>

For more information on tape and reel specifications, go to: <http://www.linear.com/tapeandree/>

## SELECTOR GUIDE

PART NUMBER		GAIN (dB)	GAIN (V/V)	$Z_{IN}$ (DIFFERENTIAL) ( $\Omega$ )	COMMENT
SINGLE	DUAL				
LTC6400-8		8	2.5	400	Lowest Distortion
LTC6400-14		14	5	200	Lowest Distortion
LTC6400-20	LTC6420-20	20	10	200	Lowest Distortion
LTC6400-26		26	20	50	Lowest Distortion
LTC6401-8		8	2.5	400	Lowest Power
LTC6401-14		14	5	200	Lowest Power
LTC6401-20	LTC6421-20	20	10	200	Lowest Power
LTC6401-26		26	20	50	Lowest Power

**DC ELECTRICAL CHARACTERISTICS** The ● denotes the specifications which apply over the full operating temperature range, otherwise specifications are at  $T_A = 25^\circ\text{C}$ .  $V^+ = 3\text{V}$ ,  $V^- = 0\text{V}$ ,  $+IN = -IN = V_{OCM} = 1.25\text{V}$ ,  $ENABLE = 0\text{V}$ , No  $R_L$  unless otherwise noted.

SYMBOL	PARAMETER	CONDITIONS	MIN	TYP	MAX	UNITS	
<b>Input/Output Characteristic</b>							
$G_{DIFF}$	Gain	$V_{IN} = \pm 100\text{mV}$ Differential	●	19.6	20	20.4	dB
$\Delta G$	Gain Matching	Channel-to-Channel	●		$\pm 0.1$	$\pm 0.25$	dB
$TC_{GAIN}$	Gain Temperature Drift	$V_{IN} = \pm 100\text{mV}$ Differential	●		0.0015		dB/ $^\circ\text{C}$
$V_{SWINGMIN}$	Output Swing Low ( $V_{OCM} = 1.5\text{V}$ )	Each Output, $V_{IN} = \pm 400\text{mV}$ Differential	●		0.2	0.35	V
$V_{SWINGMAX}$	Output Swing High ( $V_{OCM} = 1.5\text{V}$ )	Each Output, $V_{IN} = \pm 400\text{mV}$ Differential	●	2.65	2.8		V
$V_{OUTDIFFMAX}$	Maximum Differential Output Swing		●	4.6	5.2		$V_{P-P}$
$I_{OUT}$	Output Current Drive	$2V_{P-P, OUT}$ (Note 10)	●	20			mA
$V_{OS}$	Input Offset Voltage	Differential	●	-2	$\pm 0.4$	2	mV
$TCV_{OS}$	Input Offset Voltage Drift	Differential	●		1.2		$\mu\text{V}/^\circ\text{C}$
$I_{VRMIN}$	Input Common Mode Voltage Range, MIN		●			1	V
$I_{VRMAX}$	Input Common Mode Voltage Range, MAX		●	1.6			V
$R_{INDIFF}$	Input Resistance (+IN, -IN)	Differential	●	170	200	230	$\Omega$
$\Delta R_{IN}$	Input Impedance Matching	Channel-to-Channel	●		$\pm 0.5$	$\pm 2.5$	%
$C_{INDIFF}$	Input Capacitance (+IN, -IN)	Differential, Includes Parasitic			1		pF
$R_{OUTDIFF}$	Output Resistance (+OUT, -OUT)	Differential	●	20	25	36	$\Omega$
CMRR	Common Mode Rejection Ratio	Input Common Mode Voltage 1V to 1.6V	●	45	68		dB
<b>Output Common Mode Voltage Control</b>							
$G_{CM}$	Common Mode Gain	$V_{OCM} = 1.1\text{V}$ to $1.6\text{V}$			1		V/V
$V_{OCMMIN}$	Output Common Mode Range, MIN		●			1.1	V
$V_{OCMMAX}$	Output Common Mode Range, MAX		●	1.6			V
$V_{OSCM}$	Common Mode Offset Voltage	$V_{OCM} = 1.25\text{V}$ to $1.5\text{V}$	●	-10	$\pm 2$	10	mV
$TCV_{OSCM}$	Common Mode Offset Voltage Drift		●		16		$\mu\text{V}/^\circ\text{C}$
$I_{V_{OCM}}$	$V_{OCM}$ Input Current		●	-15	-3	0	$\mu\text{A}$
<b>ENABLE<math>\bar{x}</math> Pins (x = A, B)</b>							
$V_{IL}$	ENABLE $\bar{x}$ Input Low Voltage		●			0.8	V
$V_{IH}$	ENABLE $\bar{x}$ Input High Voltage		●	2.4			V
	ENABLE $\bar{x}$ Input Current	ENABLE $\bar{x} \leq 0.8\text{V}$ ENABLE $\bar{x} \geq 2.4\text{V}$	● ●		1.5	$\pm 0.5$ 4	$\mu\text{A}$ $\mu\text{A}$
<b>Power Supply</b>							
$V_S$	Operating Supply Range		●	2.85	3	3.5	V
$I_S$	Supply Current	ENABLE $\bar{x} \leq 0.8\text{V}$ ; per Amplifier	●		80	95	mA
$I_{SHDN}$	Shutdown Supply Current	ENABLE $\bar{x} \geq 2.4\text{V}$ ; per Amplifier. Inputs Floating	●		1	3	mA
PSRR	Power Supply Rejection Ratio (Differential Outputs)	$V^+ = 2.85\text{V}$ to $3.5\text{V}$	●	55	86		dB

## AC ELECTRICAL CHARACTERISTICS

The ● denotes the specifications which apply over the full operating temperature range, otherwise specifications are at  $T_A = 25^\circ\text{C}$ .  $V^+ = 3\text{V}$ ,  $V^- = 0\text{V}$ ,  $V_{\text{OCM}} = 1.25\text{V}$ ,  $\overline{\text{ENABLE}} = 0\text{V}$ , No  $R_L$  unless otherwise noted.

SYMBOL	PARAMETER	CONDITIONS	MIN	TYP	MAX	UNITS
$\Delta G$	Gain Matching	$f = 100\text{MHz}$ (Note 9)	●	$\pm 0.1$	$\pm 0.25$	dB
$\Delta P$	Phase Matching	$f = 100\text{MHz}$		$\pm 0.1$		deg
	Channel Separation (Note 8)	$f = 100\text{MHz}$		80		dB
$-3\text{dB BW}$	$-3\text{dB}$ Bandwidth	$200\text{mV}_{\text{P-P,OUT}}$ (Note 6)		1.8		GHz
$0.5\text{dB BW}$	Bandwidth for $0.5\text{dB}$ Flatness	$200\text{mV}_{\text{P-P,OUT}}$ (Note 6)		0.7		GHz
$0.1\text{dB BW}$	Bandwidth for $0.1\text{dB}$ Flatness	$200\text{mV}_{\text{P-P,OUT}}$ (Note 6)		0.3		GHz
NF	Noise Figure	$R_L = 375\Omega$ (Note 5), $f = 100\text{MHz}$		6.2		dB
$e_{\text{IN}}$	Input Referred Voltage Noise Density	Includes Resistors (Short Inputs), $f = 100\text{MHz}$		2.2		$\text{nV}/\sqrt{\text{Hz}}$
$e_{\text{ON}}$	Output Referred Voltage Noise Density	Includes Resistors (Short Inputs), $f = 100\text{MHz}$		22		$\text{nV}/\sqrt{\text{Hz}}$
$1/f$	$1/f$ Noise Corner			10		kHz
SR	Slew Rate	Differential (Note 6)		4500		$\text{V}/\mu\text{s}$
$t_{\text{S}1\%}$	1% Settling Time	$2V_{\text{P-P,OUT}}$ (Note 6)		0.8		ns
$t_{\text{OVDR}}$	Overdrive Recovery Time	$1.9V_{\text{P-P,OUT}}$ (Note 6): Single Ended		4		ns
$P_{1\text{dB}}$	$1\text{dB}$ Compression Point	$R_L = 375\Omega$ (Notes 5, 7), $f = 100\text{MHz}$		18		dBm
$t_{\text{ON}}$	Turn-On Time	+OUT, -OUT Within 10% of Final Values		82		ns
$t_{\text{OFF}}$	Turn-Off Time	$I_{\text{CC}}$ Falls to 10% of Nominal		190		ns
$-3\text{dB BW}_{\text{VOCM}}$	$V_{\text{OCM}}$ Pin Small Signal $-3\text{dB}$ BW	$0.1V_{\text{P-P}}$ at $V_{\text{OCM}}$ , Measured Single-Ended at Output (Note 6)		15		MHz
IMD3	3rd Order Intermodulation Distortion	$f = 100\text{MHz}$ (1MHz Spacing) $V_{\text{OUT}} = 2V_{\text{P-P}}$ Composite		-84		dBc
OIP3	3rd Order Output Intercept	$f = 100\text{MHz}$ (Note 7)		46		dBm
IIP3	3rd Order Input Intercept	$f = 100\text{MHz}$ ( $Z_{\text{IN}} = 50\Omega$ ) $f = 100\text{MHz}$ ( $Z_{\text{IN}} = 200\Omega$ )		26 20		dBm dBm
$\text{HD}_2$	2nd Order Harmonic Distortion	$f = 100\text{MHz}$ ; $V_{\text{OUT}} = 2V_{\text{P-P}}$		-80		dBc
$\text{HD}_3$	3rd Order Harmonic Distortion	$f = 100\text{MHz}$ ; $V_{\text{OUT}} = 2V_{\text{P-P}}$		-88		dBc

**Note 1:** Stresses beyond those listed under Absolute Maximum Ratings may cause permanent damage to the device. Exposure to any Absolute Maximum Rating condition for extended periods may affect device reliability and lifetime.

**Note 2:** Input pins (+IN, -IN) are protected by steering diodes to either supply. If the inputs go beyond either supply rail, the input current should be limited to less than 10mA.

**Note 3:** The LTC6420C and LTC6420I are guaranteed functional over the operating temperature range of  $-40^\circ\text{C}$  to  $85^\circ\text{C}$ .

**Note 4:** The LTC6420C is guaranteed to meet specified performance from  $0^\circ\text{C}$  to  $70^\circ\text{C}$ . It is designed, characterized and expected to meet specified performance from  $-40^\circ\text{C}$  to  $85^\circ\text{C}$  but is not tested or QA sampled at these temperatures. The LTC6420I is guaranteed to meet specified performance from  $-40^\circ\text{C}$  to  $85^\circ\text{C}$ .

**Note 5:** Input and output baluns used. See Test Circuit A.

**Note 6:** Measured using Test Circuit B.  $R_L = 87.5\Omega$  on each output.

**Note 7:** Since the LTC6420-20 is a feedback amplifier with low output impedance, a resistive load is not required when driving an AD converter. Therefore, typical output power is very small. In order to compare the LTC6420-20 with amplifiers that require  $50\Omega$  output load, the output voltage swing driving a given  $R_L$  is converted to OIP<sub>3</sub> and P<sub>1dB</sub> as if it were driving a  $50\Omega$  load. Using this modified convention,  $2V_{\text{P-P}}$  is by definition equal to 10dBm, regardless of actual  $R_L$ .

**Note 8:** Channel separation (the inverse of crosstalk) is measured by driving a signal into one input, while terminating the other input. Channel separation is the ratio of the resulting output signal at the driven channel to the channel that is not driven.

**Note 9:** Not production tested. Guaranteed by design and by correlation to production tested parameters.

**Note 10:** The output swing range is at least  $2V_{\text{P-P}}$  differential even when sourcing or sinking 20mA. Tested at  $V_{\text{OCM}} = 1.5\text{V}$ .

# TYPICAL PERFORMANCE CHARACTERISTICS

**Channel to Channel Gain Match vs Frequency**

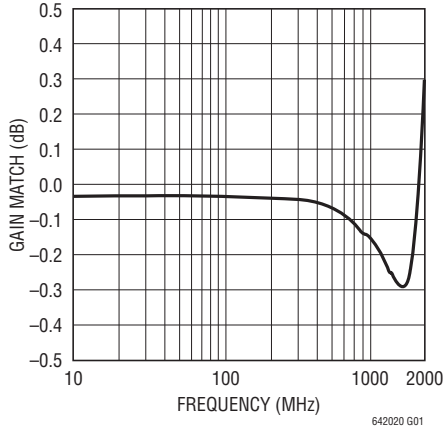

**Channel to Channel Group Delay Match vs Frequency**

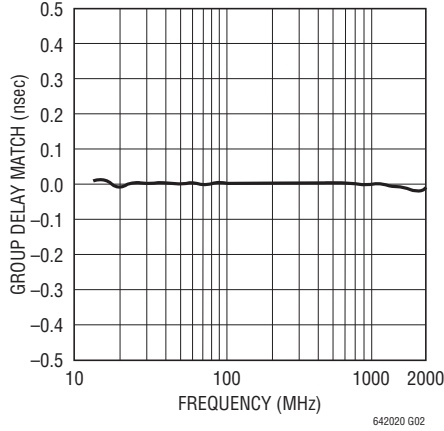

**Channel to Channel Phase Match vs Frequency**

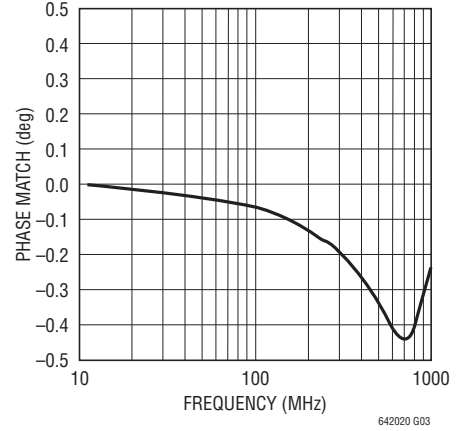

**Frequency Response**

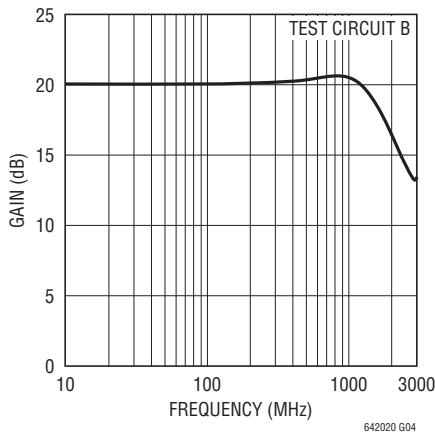

**S21 Phase and Group Delay vs Frequency**

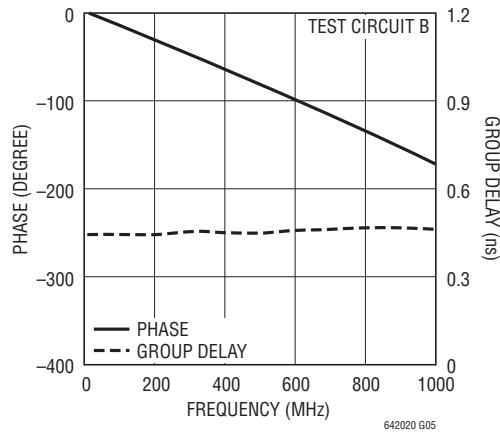

**Input and Output Reflection and Reverse Isolation vs Frequency**

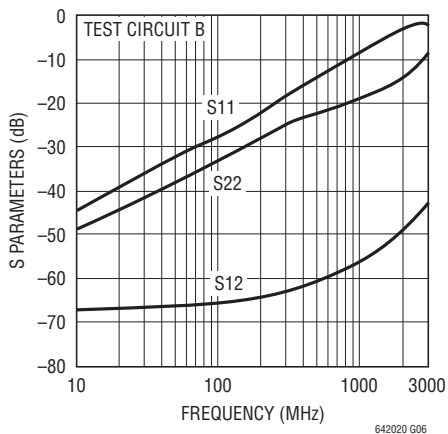

**Input and Output Impedance vs Frequency**

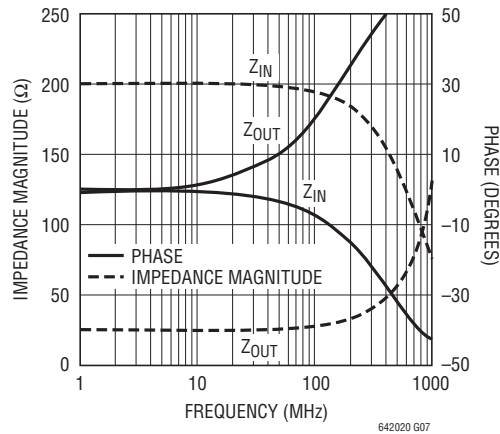

# TYPICAL PERFORMANCE CHARACTERISTICS

**Noise Figure and Input Referred Noise Voltage vs Frequency**

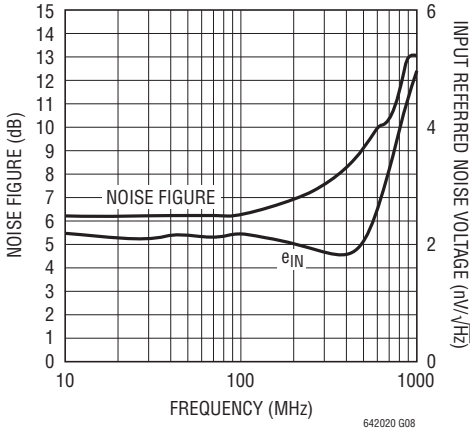

**Small Signal Transient Response**

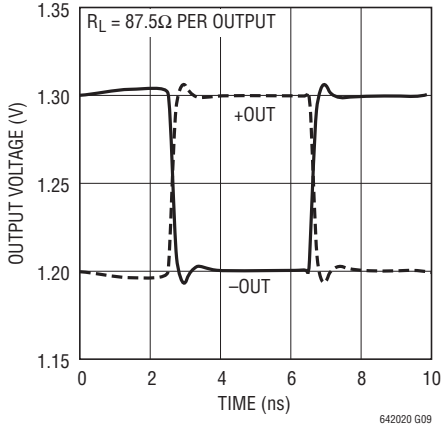

**Overdrive Transient Response**

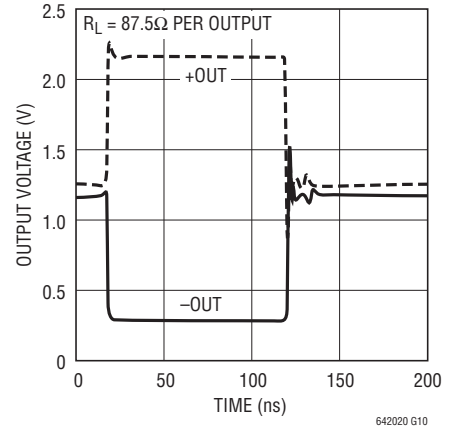

**Harmonic Distortion vs Frequency**

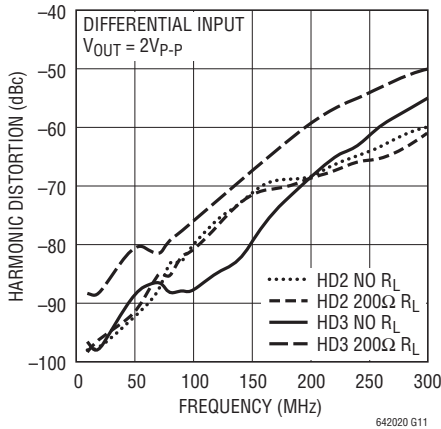

**Third Order Intermodulation Distortion vs Frequency**

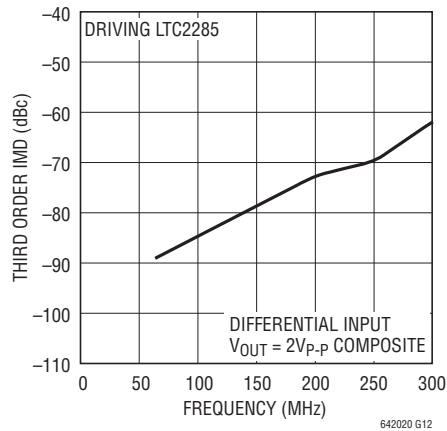

**Equivalent Output Third Order Intercept vs Frequency**

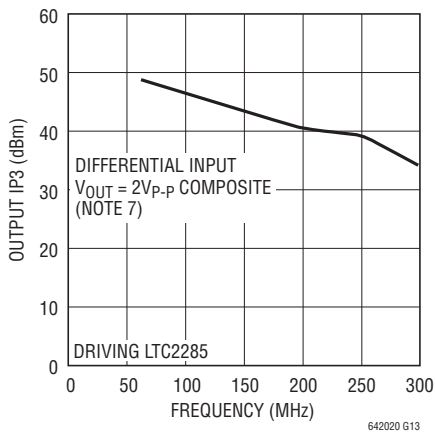

**Channel Separation vs Frequency (Note 8)**

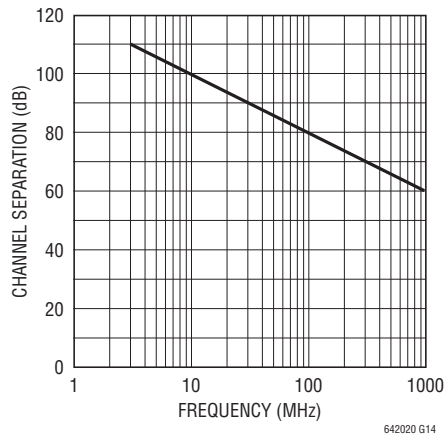

## PIN FUNCTIONS

**+INA, -INA, -INB, +INB (Pins 1, 2, 5, 6):** Differential Inputs of A and B channel respectively.

**V<sup>-</sup> (Pins 3, 4, 13, 14, 21):** Negative Power Supply. All four pins, as well as the exposed back, must be connected to same voltage/ground.

**ENABLEA, ENABLEB (Pins 9, 18):** Logic inputs. If low, the amplifier is enabled. If high, the amplifier is disabled and placed in a low power shutdown mode, making the amplifier outputs high impedance. These pins are internally separate. These pins should not be left floating.

**V<sup>+</sup> A, V<sup>+</sup> B (Pins 15, 20, 7, 12):** Positive Power Supply (Normally tied to 3V or 3.3V). Supply pins of A and B channels are internally separate. Bypass each pin with 1000pF and 0.1μF capacitors as close to the pins as possible.

**-OUTA, +OUTA, -OUTB, +OUTB (Pins 16, 17, 11, 10):** Differential Outputs of channels A and B respectively.

**V<sub>OCMA</sub>, V<sub>OCMB</sub> (Pins 19, 8):** These pins set the output common mode voltage for the respective channel. They are internally separate. A 0.1μF external bypass capacitor is recommended.

**Exposed Pad (Pin 21):** V<sup>-</sup>. The Exposed Pad must be connected to same voltage/ground as pins 3, 4, 13, 14.

## BLOCK DIAGRAM

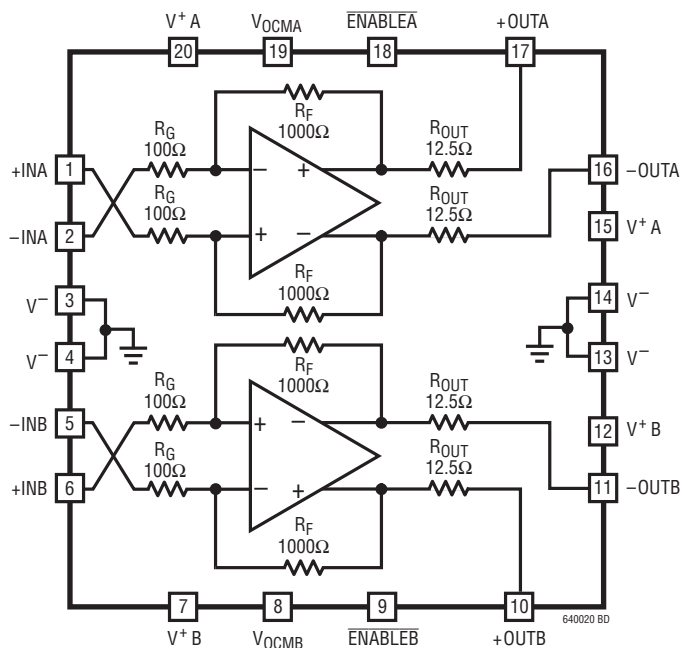

## APPLICATIONS INFORMATION

### Circuit Operation

Each of the two channels of the LTC6420-20 is composed of a fully differential amplifier with on chip feedback and output common mode voltage control circuitry. Differential gain and input impedance are set by  $100\Omega/1000\Omega$  resistors in the feedback network. Small output resistors of  $12.5\Omega$  improve the circuit stability over various load conditions.

The LTC6420-20 is very flexible in terms of I/O coupling. It can be AC- or DC-coupled at the inputs, the outputs or both. If the inputs are AC-coupled, the input common mode voltage is automatically biased close to  $V_{OCM}$  and thus no external circuitry is needed for bias. The LTC6420-20 provides an output common mode voltage set by  $V_{OCM}$ , which allows driving an ADC directly without external components such as a transformer or AC coupling capacitors. The input signal can be either single-ended or differential with only minor differences in distortion performance.

### Input Impedance and Matching

The differential input impedance of the LTC6420-20 is  $200\Omega$ . If a  $200\Omega$  source impedance is unavailable, then the differential inputs may need to be terminated to a lower value impedance, e.g.  $50\Omega$ , in order to provide an impedance match for the source. Several choices are available. One approach is to use a differential shunt resistor (Figure 1). Another approach is to employ a wide band transformer (Figure 2). Both methods provide a wide band impedance match. The termination resistor or the transformer must be placed close to the input pins in order to minimize the reflection due to input mismatch. Alternatively, one could apply a narrowband impedance match at the inputs of the LTC6420-20 for frequency selection and/or noise reduction.

Referring to Figure 3, LTC6420-20 can be easily configured for single-ended input and differential output without a balun. The signal is fed to one of the inputs through a

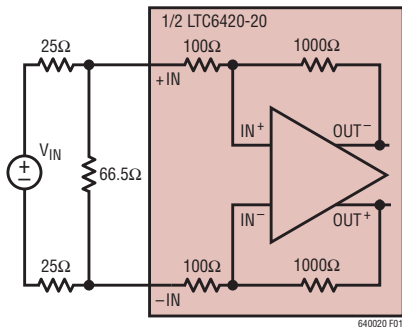

Figure 1. Input Termination for Differential  $50\Omega$  Input Impedance Using Shunt Resistor

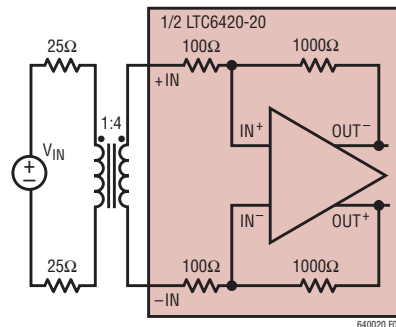

Figure 2. Input Termination for Differential  $50\Omega$  Input Impedance Using a 1:4 Balun

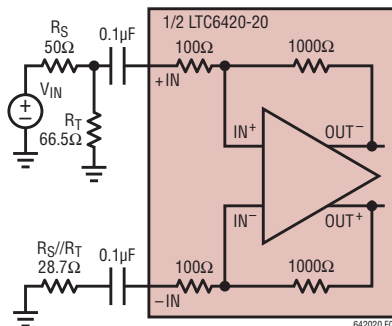

Figure 3. Input Termination for Single-Ended  $50\Omega$  Input Impedance

## APPLICATIONS INFORMATION

matching network while the other input is connected to the same matching network and a source resistor. Because the return ratios of the two feedback paths are equal, the two outputs have the same gain and thus symmetrical swing. In general, the single-ended input impedance and termination resistor  $R_T$  are determined by the combination of  $R_S$ ,  $R_G$  and  $R_F$ . For example, when  $R_S$  is  $50\Omega$ , it is found that the single-ended input impedance is  $202\Omega$  and  $R_T$  is  $66.5\Omega$  in order to match to a  $50\Omega$  source impedance.

The LTC6420-20 is unconditionally stable. However, the overall differential gain is affected by both source impedance and load impedance as follows:

$$A_V = \left| \frac{V_{OUT}}{V_{IN}} \right| = \frac{2000}{R_S + 200} \cdot \frac{R_L}{25 + R_L}$$

### Output Impedance Match

The LTC6420-20 can drive an ADC directly without external output impedance matching. Alternatively, the differential output impedance of  $25\Omega$  can be matched to a higher value impedance, e.g.  $50\Omega$ , by series resistors or an LC network.

### Output Common Mode Adjustment

The output common mode voltage is set by the  $V_{OCM}$  pin, which is a high impedance input. The output common mode voltage is capable of tracking  $V_{OCM}$  in a range from 1.1V to 1.6V. The bandwidth of  $V_{OCM}$  control is typically 15MHz, which is dominated by a low pass filter connected to the  $V_{OCM}$  pin and is aimed to reduce common mode noise generation at the outputs. The internal common mode feedback loop has a  $-3\text{dB}$  bandwidth of 300MHz, allowing fast rejection of any common mode output voltage disturbance. The  $V_{OCM}$  pin should be tied to a DC bias voltage with a  $0.1\mu\text{F}$  bypass capacitor. When interfacing with A/D converters such as the LTC22xx families, the  $V_{OCM}$  pin can be connected to the  $V_{CM}$  pin of the ADC.

### Driving A/D Converters

The LTC6420-20 has been specifically designed to interface directly with high speed A/D converters. The back page of this data sheet shows the LTC6420-20 driving an LTC2285, which is a dual 14-bit, 125MSPS ADC.

The  $V_{OCM}$  pins of the LTC6420-20 are connected to the  $V_{CM}$  pins of the LTC2285, which provide a DC voltage level of 1.5V. Both ICs are powered from the same 3V supply voltage.

The inputs to the LTC6420-20 can be configured in various ways, as described in the Input Impedance and Matching section of this data sheet. The outputs of the LTC6420-20 may be connected directly to the analog inputs of an ADC, or a simple lowpass or bandpass filter network may be inserted to reduce out-of-band noise.

### Test Circuits

Due to the fully-differential design of the LTC6420 and its usefulness in applications with differing characteristic specifications, two test circuits are used to generate the information in this data sheet. Test Circuit A is DC1299, a two-port demonstration circuit for the LTC6420/LTC6421 family. The schematic and silkscreen are shown in Figure 4. This circuit includes input and output transformers (baluns) for single-ended-to-differential conversion and impedance transformation, allowing direct hook-up to a 2-port network analyzer. There are also series resistors at the output to avoid loading the amplifier directly with a  $50\Omega$  load. Due to the input and output transformers, the  $-3\text{dB}$  bandwidth is reduced from 1.8GHz to approximately 1.3GHz.

Test Circuit B uses a 4-port network analyzer to measure S-parameters and gain/phase response. This removes the effects of the wideband baluns and associated circuitry, for a true picture of the  $>1\text{GHz}$  S-parameters and AC characteristics.

## APPLICATIONS INFORMATION

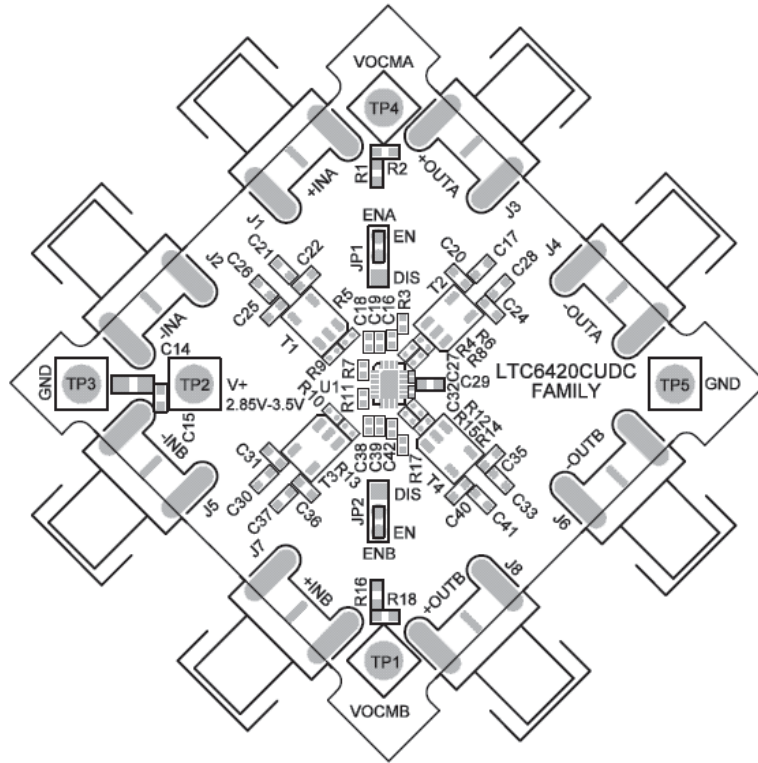

Figure 4a. Top Silkscreen of DC1299, Test Circuit A

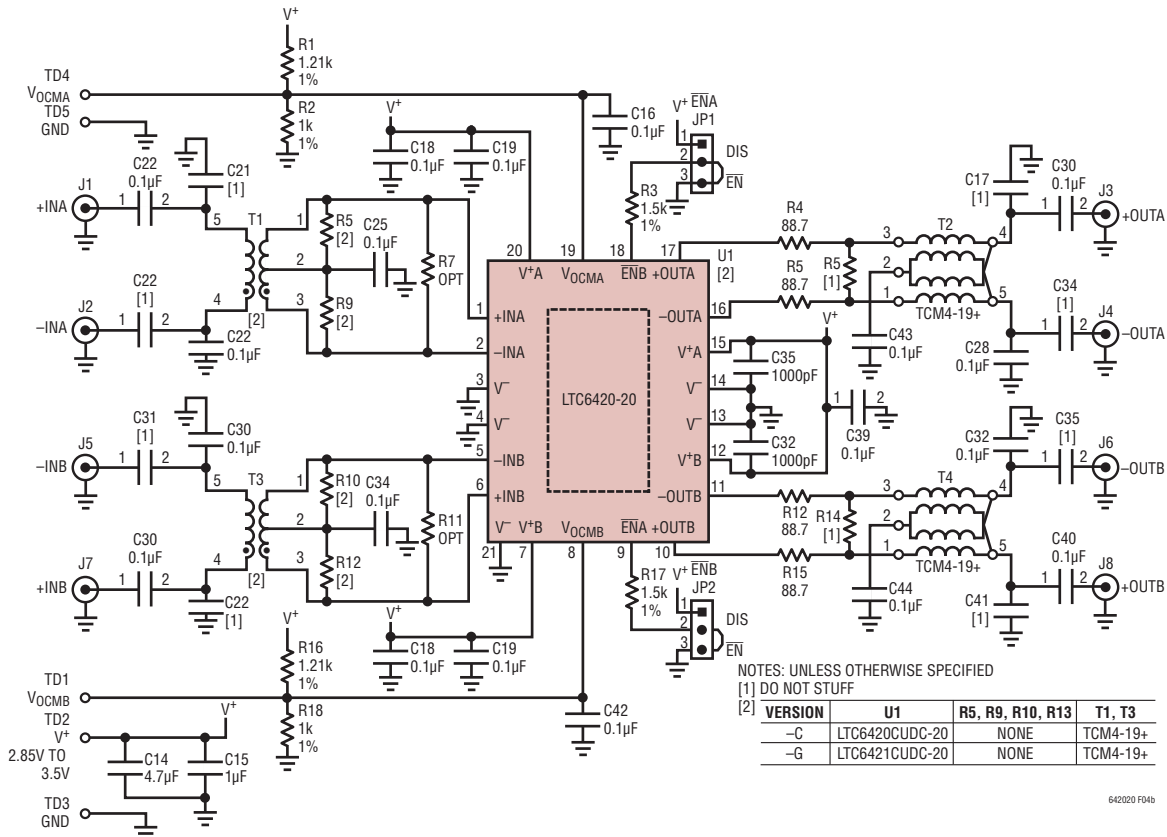
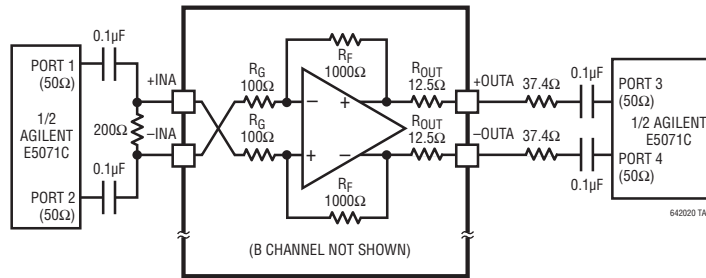

Figure 4b. Demo Circuit 1299 Schematic (Test Circuit A)

# TYPICAL APPLICATIONS

**Test Circuit B, 4-Port Measurements**  
(Only the Signal-Path Connections Are Shown)



**Parallel ADC Drivers to Reduce Wideband Noise**

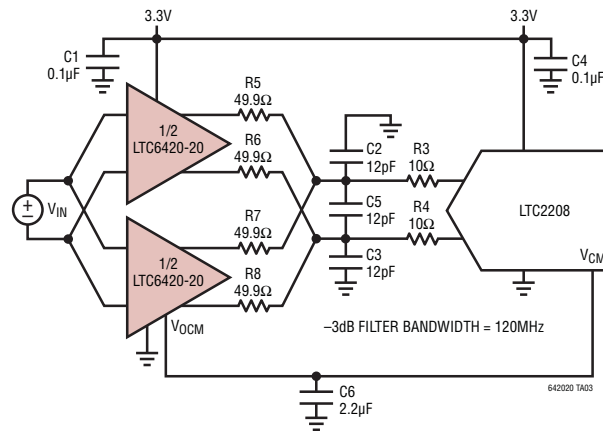

## PACKAGE DESCRIPTION

**UDC Package**  
**20-Lead Plastic QFN (3mm × 4mm)**  
 (Reference LTC DWG # 05-08-1742 Rev 0)

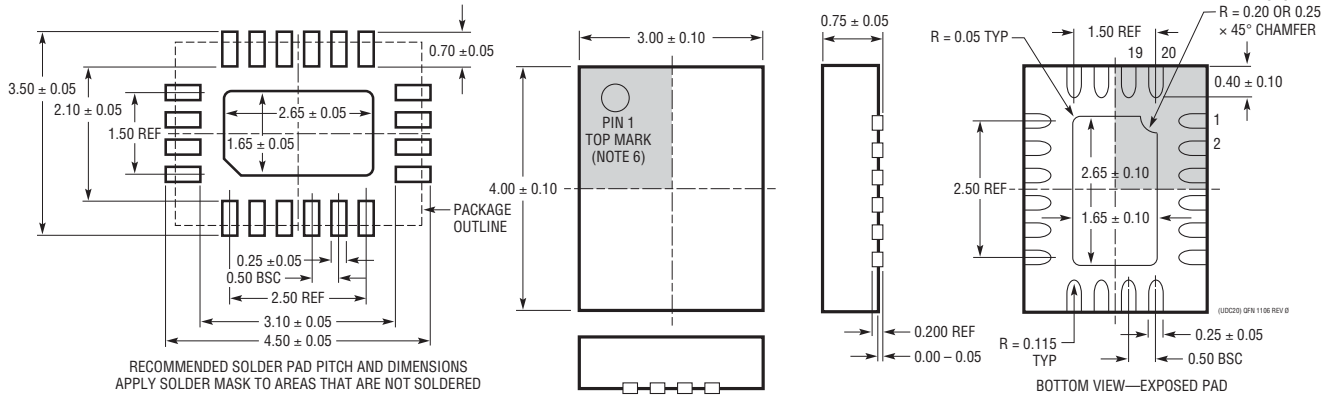

- NOTE:
1. DRAWING IS NOT A JEDEC PACKAGE OUTLINE
  2. DRAWING NOT TO SCALE
  3. ALL DIMENSIONS ARE IN MILLIMETERS
  4. DIMENSIONS OF EXPOSED PAD ON BOTTOM OF PACKAGE DO NOT INCLUDE MOLD FLASH. MOLD FLASH, IF PRESENT, SHALL NOT EXCEED 0.15mm ON ANY SIDE
  5. EXPOSED PAD SHALL BE SOLDER PLATED
  6. SHADED AREA IS ONLY A REFERENCE FOR PIN 1 LOCATION ON THE TOP AND BOTTOM OF PACKAGE

**REVISION HISTORY** (Revision history begins at Rev B)

REV	DATE	DESCRIPTION	PAGE NUMBER
B	3/10	Changes to Applications	1
		Changes to Related Parts	14

## TYPICAL APPLICATION

Dual ADC Driver for Wideband Direct-Conversion Receivers

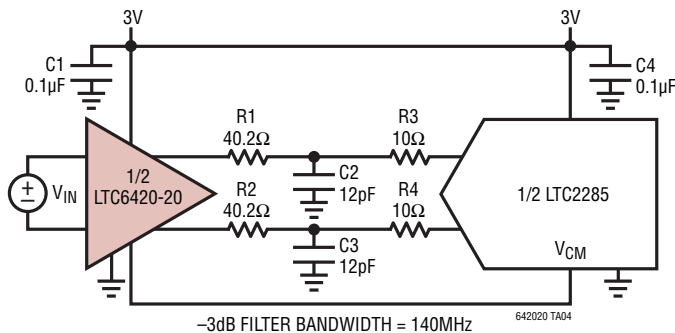

## RELATED PARTS

PART NUMBER	DESCRIPTION	COMMENTS
<b>High-Speed Differential Amplifiers/Differential Op Amps</b>		
LT <sup>®</sup> 1993-2	800MHz Differential Amplifier/ADC Driver	$A_V = 2V/V$ , OIP3 = 38dBm at 70MHz
LT1993-4	900MHz Differential Amplifier/ADC Driver	$A_V = 4V/V$ , OIP3 = 40dBm at 70MHz
LT1993-10	700MHz Differential Amplifier/ADC Driver	$A_V = 10V/V$ , OIP3 = 40dBm at 70MHz
LT1994	Low Noise, Low Distortion Differential Op Amp	16-Bit SNR and SFDR at 1MHz, Rail-to-Rail Outputs
LT5514	Ultralow Distortion IF Amplifier/ADC Driver with Digitally Controlled Gain	OIP3 = 47dBm at 100MHz, Gain Control Range 10.5dB to 33dB
LT5524	Low Distortion IF Amplifier/ADC Driver with Digitally Controlled Gain	OIP3 = 40dBm at 100MHz, Gain Control Range 4.5dB to 37dB
LT6402-6	300MHz Differential Amplifier/ADC Driver	$A_V = 6dB$ , Distortion < -80dBc at 25MHz
LT6402-12	300MHz Differential Amplifier/ADC Driver	$A_V = 12dB$ , Distortion < -80dBc at 25MHz
LT6402-20	300MHz Differential Amplifier/ADC Driver	$A_V = 20dB$ , Distortion < -80dBc at 25MHz
LT6411	Low Power Differential ADC Driver/Dual Selectable Gain Amplifier	16mA Supply Current, IMD3 = -83dBc at 70MHz, $A_V = 1, -1$ or 2
LTC6400-8/ LTC6400-14/ LTC6400-20/ LTC6400-26	Low Noise, Low Distortion, Differential ADC Drivers	$A_V = 8dB, 14dB, 20dB, 26dB$ ; Single Amplifier per IC, High Performance
LTC6401-8/ LTC6401-14/ LTC6401-20/ LTC6401-26	Low Noise, Low Distortion, Differential ADC Drivers	$A_V = 8dB, 14dB, 20dB, 26dB$ ; Single Amplifier per IC, Low Power
LTC6404	Low Noise Rail-to-Rail Output Differential Amplifier/ADC Driver	$1.5nV/\sqrt{Hz}$ , -92dB Distortion at 10MHz
LTC6406	3GHz Rail-to-Rail Input Differential Op Amp	$1.6nV/\sqrt{Hz}$ Noise, -72dBc Distortion at 50MHz, 18mA

## Looking for pricing, stock, or lifecycle information?

Click below to explore more details on WIN SOURCE:

- ⊖ [View LTC6420CUDC-20#PBF on WIN SOURCE](#)
- ⊖ [Analog Devices Inc. Information](#)

## Optimize Your Supply Chain with WIN SOURCE Solutions

- ✓ Global Sourcing Solution
- ✓ Obsolete Management
- ✓ Cost Control Management
- ✓ Shortage Management
- ✓ Alternative Solution
- ✓ Excess Inventory Management