



ON Semiconductor®

<http://onsemi.com>

# LV5710GP

Bi-CMOS LSI

## Power Supply for Charge Pump for Camera Sensor

### Overview

The LV5710GP is power supply for charge pump for camera sensor.

### Functions

- Regulating the 5V input by boosting it three-fold with the charge pump to the specified voltage.
- Output voltage variable with external resistor.
- Soft start function incorporated, which reduces the rush current at start of charge pump.
- Timer-latch type short-circuit protective function incorporated.

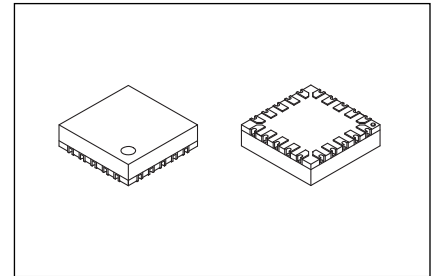

VCT20 3x3, 0.5P

### Specifications

#### Absolute Maximum Ratings at $T_a = 25^\circ\text{C}$

Parameter	Symbol	Conditions	Ratings	Unit
Maximum supply voltage	$V_{DD\ max}$		6.0	V
Allowable power dissipation	$P_d\ max$	with specified substrate *	0.55	W
Operating temperature	$T_{opr}$		-20 to +80	$^\circ\text{C}$
Storage temperature	$T_{stg}$		-40 to +125	$^\circ\text{C}$

\* : Specified substrate : 114.3mm×76.1mm×1.6mm, glass epoxy board

Stresses exceeding those listed in the Maximum Ratings table may damage the device. If any of these limits are exceeded, device functionality should not be assumed, damage may occur and reliability may be affected.

#### Allowable Operating Ratings at $T_a = 25^\circ\text{C}$

Parameter	Symbol	Conditions	Ratings			Unit
			min	typ	max	
Supply voltage	$V_{DD}$		4.5		5.5	V
Input "H" voltage	$V_{INH}$	EN pin	1.5		$V_{DD}$	V
Input "L" voltage	$V_{INL}$	EN pin	-0.1		0.4	V

Functional operation above the stresses listed in the Recommended Operating Ranges is not implied. Extended exposure to stresses beyond the Recommended Operating Ranges limits may affect device reliability.

### ORDERING INFORMATION

See detailed ordering and shipping information on page 7 of this data sheet.

# LV5710GP

**Electrical Characteristics** at  $T_a = 25^\circ\text{C}$ ,  $V_{DD} = 5\text{V}$ ,  $I_{OUT} = 30\text{mA}$ ,  $S0 = L$ ,  $S1 = L$ , Unless otherwise specified

Parameter	Symbol	Conditions	Ratings			Unit
			min	typ	max	
Circuit current drain	$I_{DD1}$	EN = L			1	$\mu\text{A}$
	$I_{DD2}$	EN = H No load		12	18	mA
Output load current	$I_{O\text{ ave}}$	At $V_{OUT} = 12\text{V}$ setting			30	mA
Reference voltage	$V_{REF}$	$V_{DD} = 4.5$ to $5.5\text{V}$	1.285	1.305	1.325	V
		$T_a = -20^\circ\text{C}$ to $+80^\circ\text{C}$ , Design value	1.279		1.331	V
Output voltage at OFF	$V_{OFF}$	After capacitive discharge	-50	0	50	mV
Protective circuit masking time	$T_{mask}$	Masking time from detection of short-circuit to IC OFF		18	33	ms
Short-circuit protective current	$I_{lim}$		35	50	65	mA
Short-circuit protective voltage	$V_{lim}$		82.5	87.5	92.5	%
SS end time	$T_{SSEND}$	Time from EN = H to regulator SS OFF $T_a = -20^\circ\text{C}$ to $+80^\circ\text{C}$ Design value			10	ms
RO load regulation	$\Delta RO$	Load $1\text{mA} \rightarrow 30\text{mA}$		30	40	mV
Input pin current	$I_{in}$	Pins EN	30	40	50	$\mu\text{A}$
		S0 and S1 pins			1	$\mu\text{A}$
Power efficiency	$P_{eff}$	CP+regulator		70		%
Rush current	$I_{rush}$	No load			300	mA
Oscillation frequency	$f_{clk}$		1.4	1.8	2.3	MHz

Product parametric performance is indicated in the Electrical Characteristics for the listed test conditions, unless otherwise noted. Product performance may not be indicated by the Electrical Characteristics if operated under different conditions.

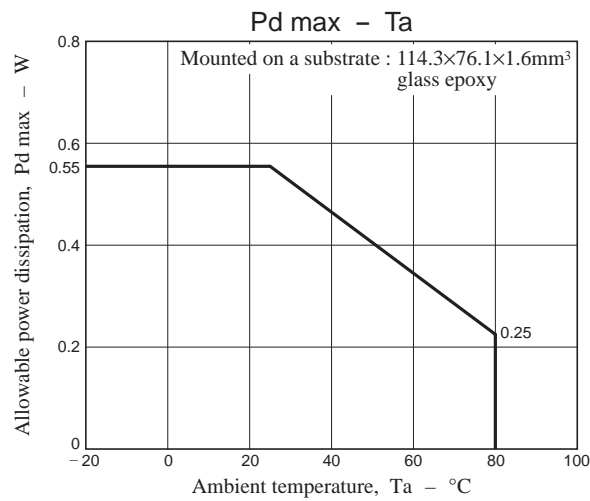

# LV5710GP

## Package Dimensions

unit : mm

VCT20 3x3, 0.5P  
CASE 601AB  
ISSUE A

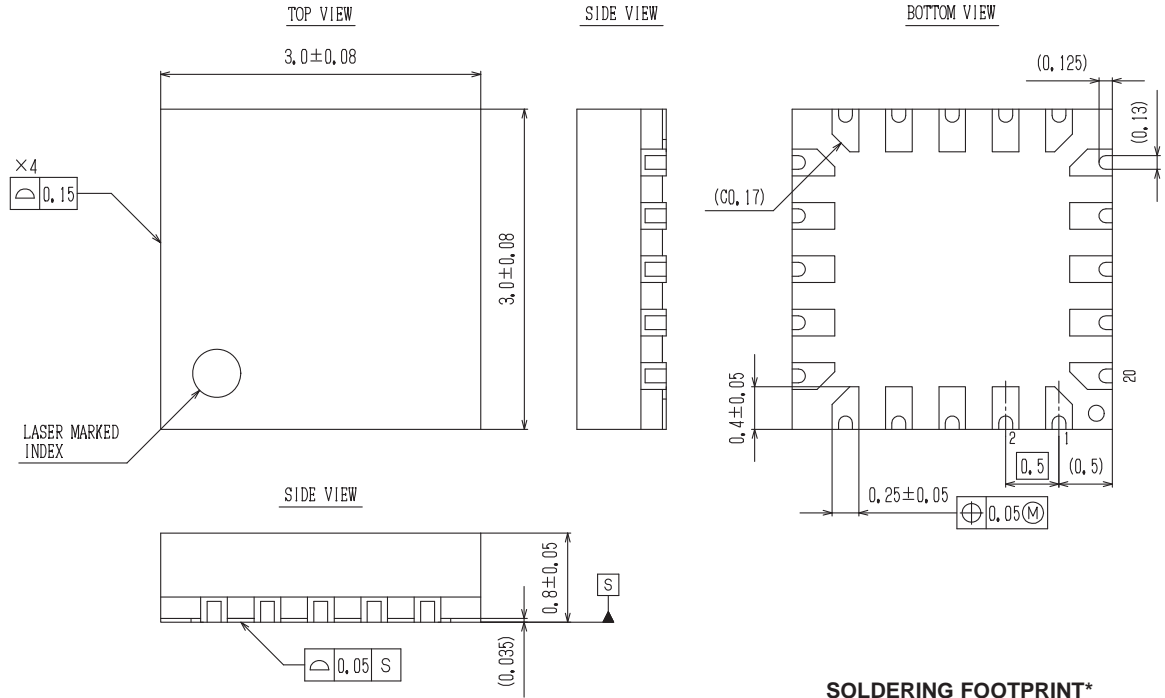

### GENERIC MARKING DIAGRAM\*

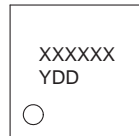
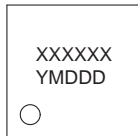

XXXXXX = Specific Device Code  
Y = Year  
M = Month  
DDD = Additional Traceability Data

XXXXXX = Specific Device Code  
Y = Year  
DD = Additional Traceability Data

\*This information is generic. Please refer to device data sheet for actual part marking.  
Pb-Free indicator, "G" or microdot "▪", may or may not be present.

### SOLDERING FOOTPRINT\*

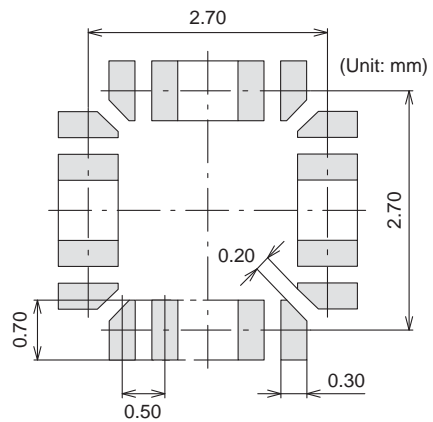

NOTE: The measurements are not to guarantee but for reference only.

\*For additional information on our Pb-Free strategy and soldering details, please download the ON Semiconductor Soldering and Mounting Techniques Reference Manual, SOLDERRM/D.

# LV5710GP

## Pin Assignment

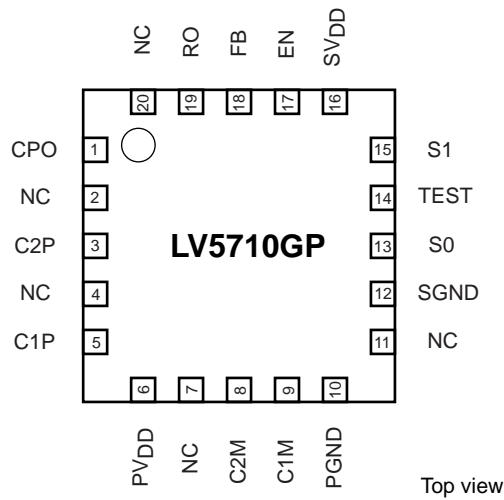

## Pin Function

Pin No.	Name	Function
1	CPO	Boost voltage output (6V <sub>DD</sub> or 5V <sub>DD</sub> )
2	NC	
3	C2P	Boost capacitor connection pin (charge transfer side)
4	NC	
5	C1P	Boost capacitor connection pin (charge transfer side)
6	PV <sub>DD</sub>	Power system V <sub>DD</sub> pin
7	NC	
8	C2M	Boost capacitor connection pin (driver side)
9	C1M	Boost capacitor connection pin (driver side)
10	PGND	Power GND pin for the charge pump
11	NC	
12	SGND	Small signal system GND pin
13	S0	Charge pump frequency changeover pin
14	TEST	Test pin (open or short-circuited to GND)
15	S1	Charge pump frequency changeover pin
16	SV <sub>DD</sub>	Small signal system V <sub>DD</sub> pin
17	EN	System enable pin (Hi active)
18	FB	Regulator FB pin
19	RO	Regulator output pin
20	NC	

Block Diagram

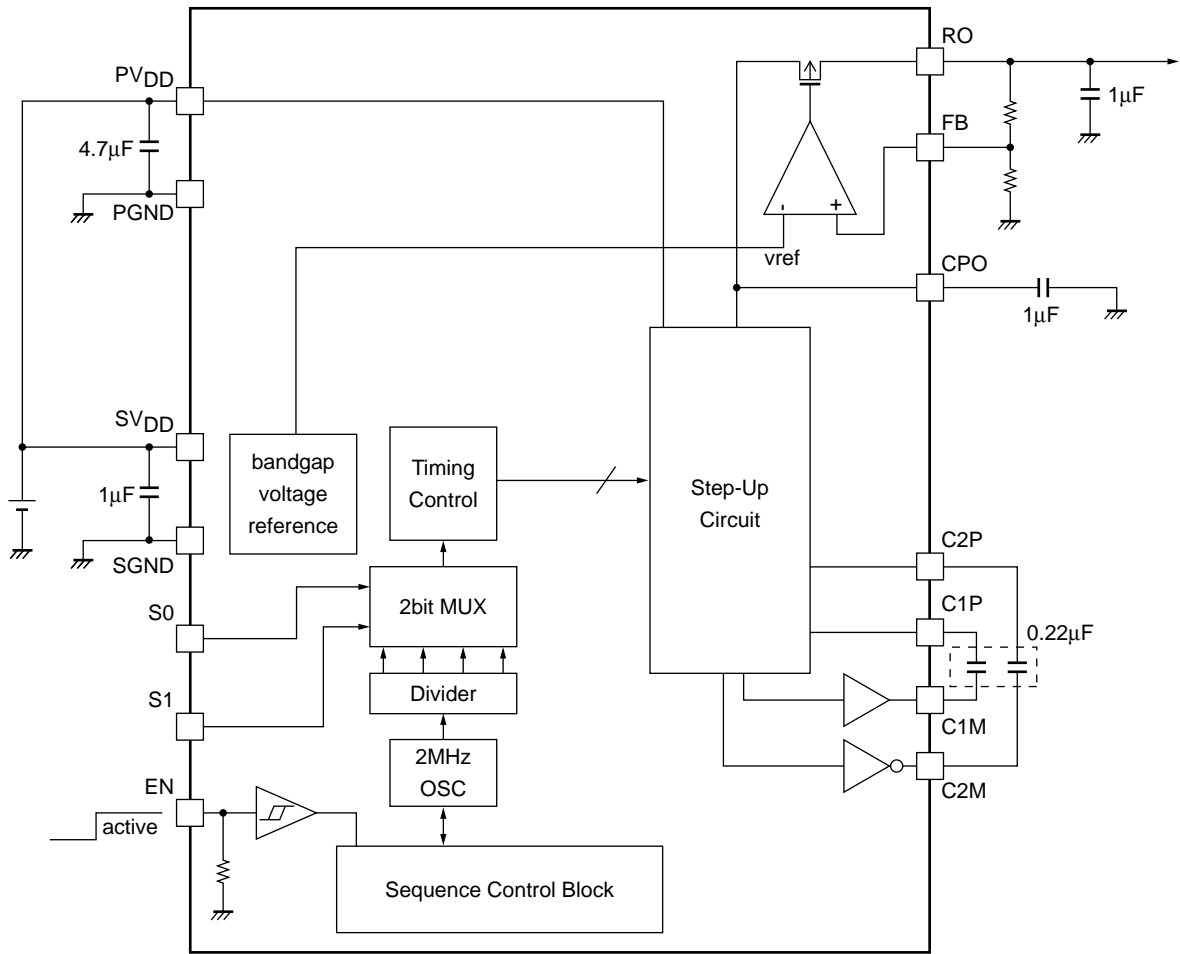

Equivalent Circuit Diagram

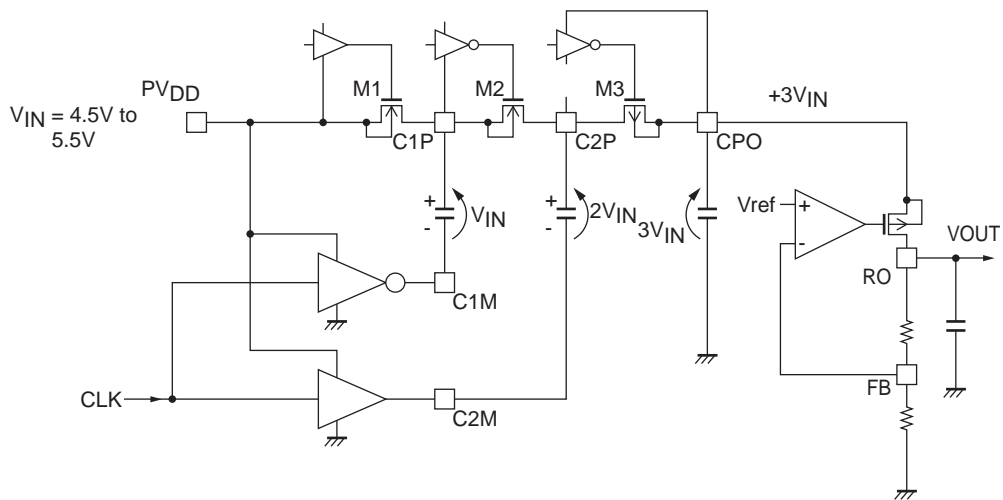

## Output Voltage Setting Method

The output voltage of IC-incorporated LDO can be determined as follows :

$$V_H = \frac{R1+R2}{R2} \times V_{REF}$$

For example, to set the output voltage to 12V, set the resistance Value to  $R1 = 1070k\Omega/R2 = 130k\Omega$ .

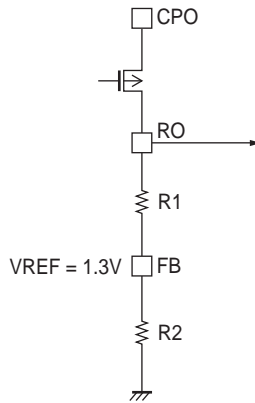

## Short-circuit Protective Operation

The RO output pin has the short-circuit protective function.

The over-current detector circuit outputs the detection signal when the output current of 50mA (typ) or more flows or when the output voltage drops below 87.5% (typ). When this detection signal is output continuously for 18ms (typ) or more, IC determines that there is over-current and stops the output. To reset from the stop state, set the EN pin to “L”, then set the EN pin to “H” again.

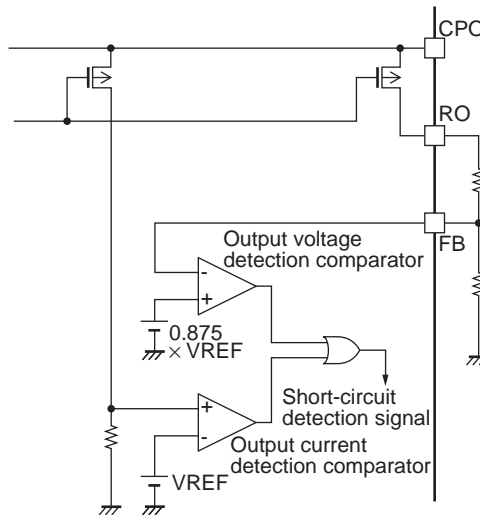

Equivalent circuit of the over-current detection circuit

## Selecting the Frequency

According to the logic of S0 and S1, the charge pump operation frequency can be changed.

In the case of light load, the reactive power can be reduced by decreasing the operating frequency.

S0	S1	CP operating frequency
L	L	1MHz
H	L	500kHz
L	H	250kHz
H	H	125kHz

# LV5710GP

## Startup sequence

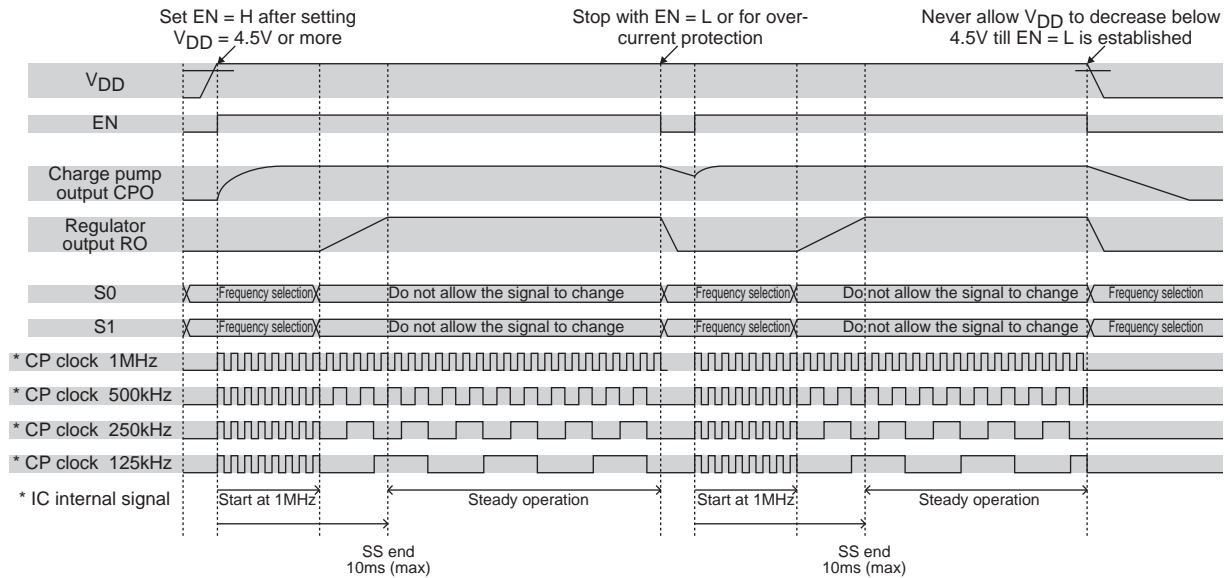

## EN Pin and VDD

The sequence operation is made at startup. However, startup is not made when the internal circuit has not been reset. To reset the internal circuit, keep the EN pin to “L” till VDD becomes 4.5V or more. Note that VDD and EN pin cannot be short-circuited for this purpose.



## ORDERING INFORMATION

Device	Package	Shipping (Qty / Packing)
LV5710GP-TE-L-H	VCT20 3x3, 0.5P (Pb-Free / Halogen Free)	2000 / Tape & Reel

ON Semiconductor and the ON logo are registered trademarks of Semiconductor Components Industries, LLC (SCILLC) or its subsidiaries in the United States and/or other countries. SCILLC owns the rights to a number of patents, trademarks, copyrights, trade secrets, and other intellectual property. A listing of SCILLC's product/patent coverage may be accessed at [www.onsemi.com/site/pdf/Patent-Marking.pdf](http://www.onsemi.com/site/pdf/Patent-Marking.pdf). SCILLC reserves the right to make changes without further notice to any products herein. SCILLC makes no warranty, representation or guarantee regarding the suitability of its products for any particular purpose, nor does SCILLC assume any liability arising out of the application or use of any product or circuit, and specifically disclaims any and all liability, including without limitation special, consequential or incidental damages. "Typical" parameters which may be provided in SCILLC data sheets and/or specifications can and do vary in different applications and actual performance may vary over time. All operating parameters, including "Typicals" must be validated for each customer application by customer's technical experts. SCILLC does not convey any license under its patent rights nor the rights of others. SCILLC products are not designed, intended, or authorized for use as components in systems intended for surgical implant into the body, or other applications intended to support or sustain life, or for any other application in which the failure of the SCILLC product could create a situation where personal injury or death may occur. Should Buyer purchase or use SCILLC products for any such unintended or unauthorized application, Buyer shall indemnify and hold SCILLC and its officers, employees, subsidiaries, affiliates, and distributors harmless against all claims, costs, damages, and expenses, and reasonable attorney fees arising out of, directly or indirectly, any claim of personal injury or death associated with such unintended or unauthorized use, even if such claim alleges that SCILLC was negligent regarding the design or manufacture of the part. SCILLC is an Equal Opportunity/Affirmative Action Employer. This literature is subject to all applicable copyright laws and is not for resale in any manner.

## Looking for pricing, stock, or lifecycle information?

Click below to explore more details on WIN SOURCE:

-  [View LV5710GP-TE-L-H on WIN SOURCE](#)
-  [ON Semiconductor](#) Information

## Optimize Your Supply Chain with WIN SOURCE Solutions

-  Global Sourcing Solution
-  Obsolete Management
-  Cost Control Management
-  Shortage Management
-  Alternative Solution
-  Excess Inventory Management